

LOCALE	CODICE	DESCRIZIONE COMPONENTE	FINITURA	GR.
PORTE	MD321_MF_P01	PORTA BAGNO VIP		PTP

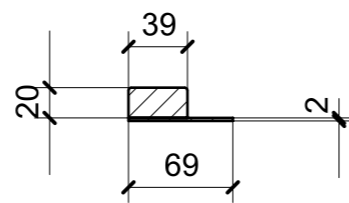

SECTION A-A

ELEMENTI DA MONTARE  
in MF\_P01  
e spedire con unico imballo

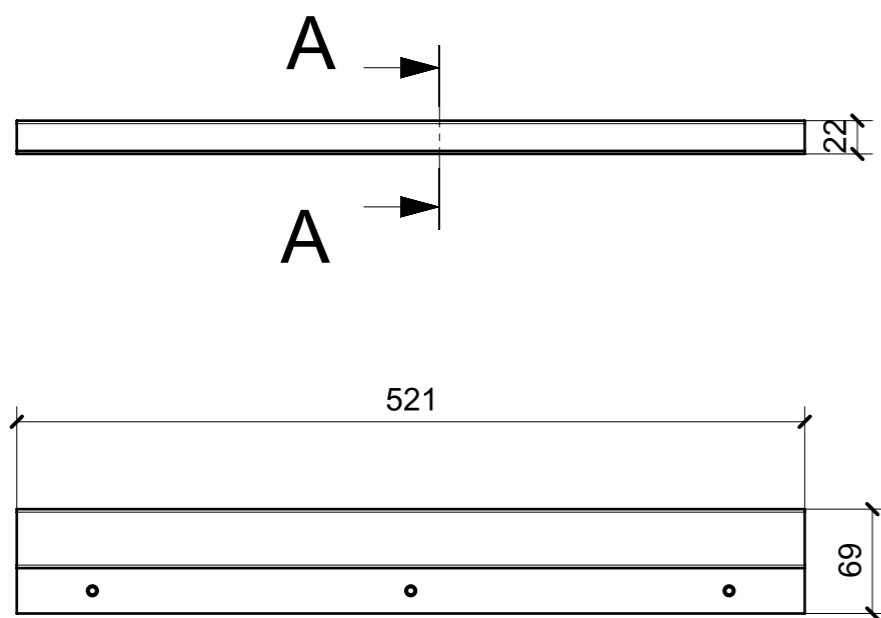
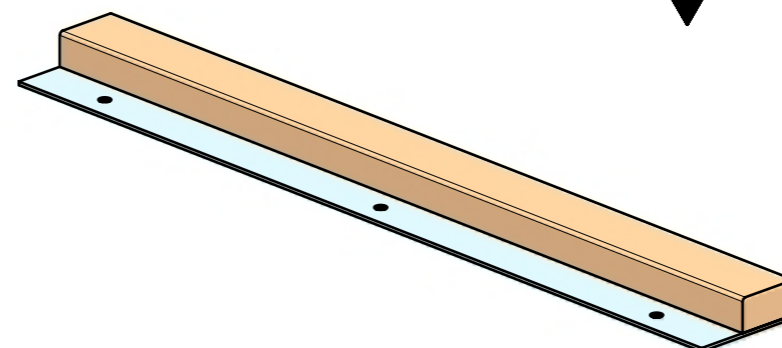
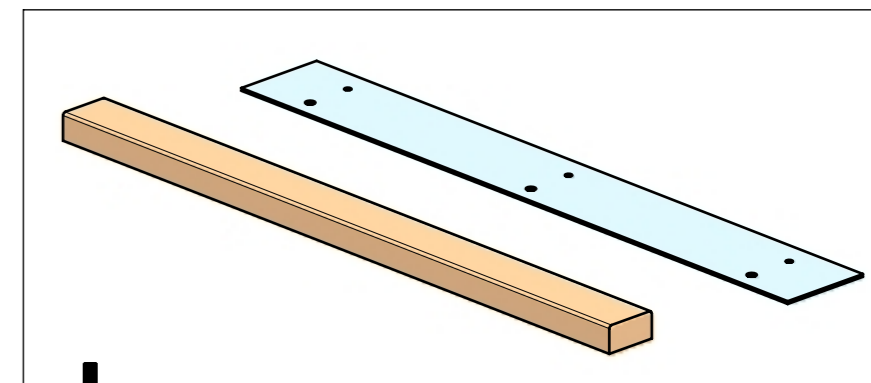

MF\_P01

LOCALE	CODICE	DESCRIZIONE COMPONENTE	FINITURA	GR.
PORTE	MD321_MF_P02	PORTA CABINA VIP		PTP

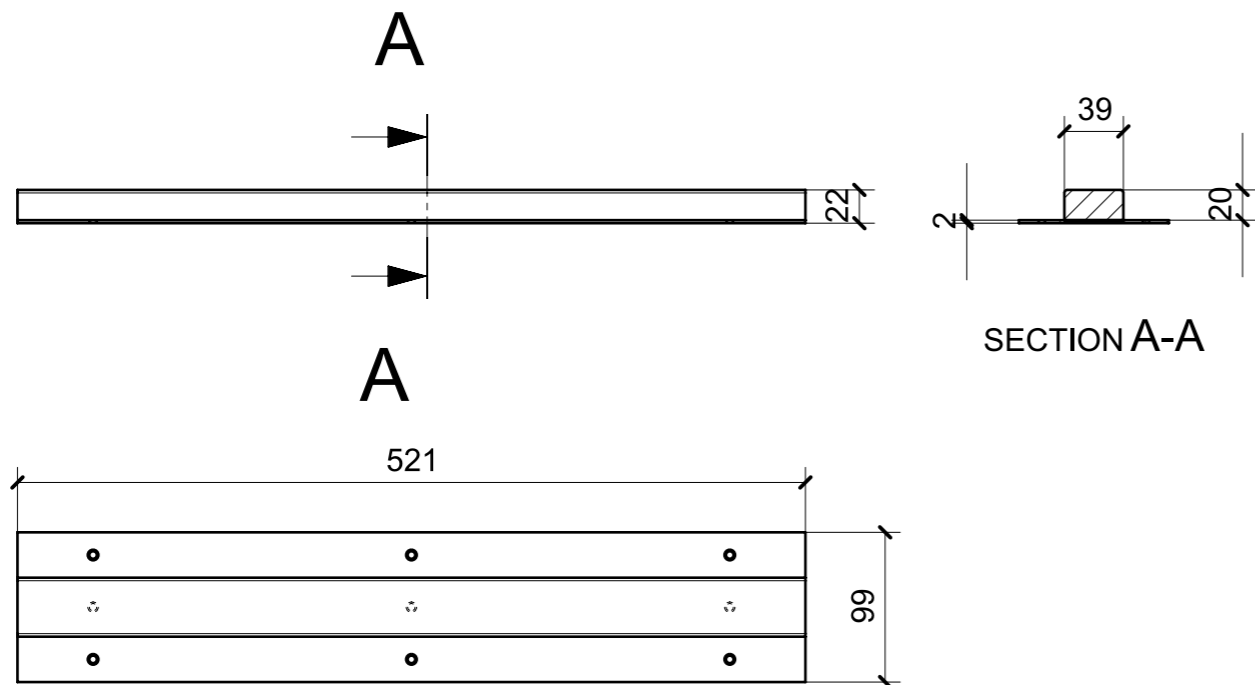

MF\_P02

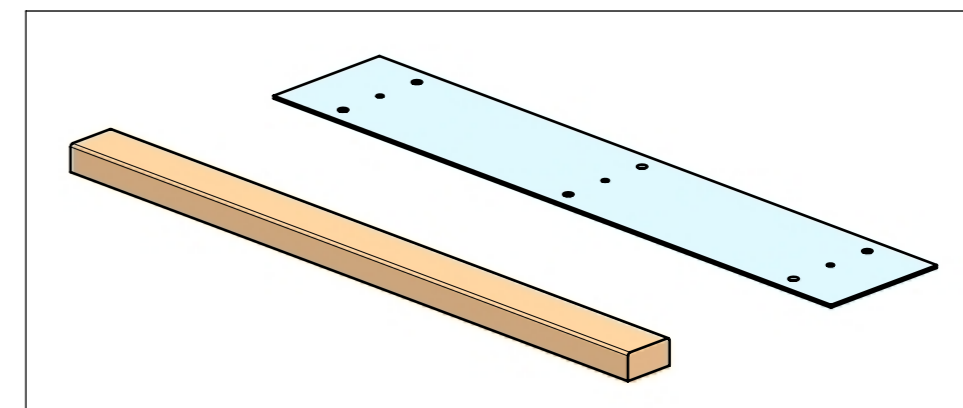

ELEMENTI DA MONTARE  
in MF\_P02  
e spedire con unico imballo

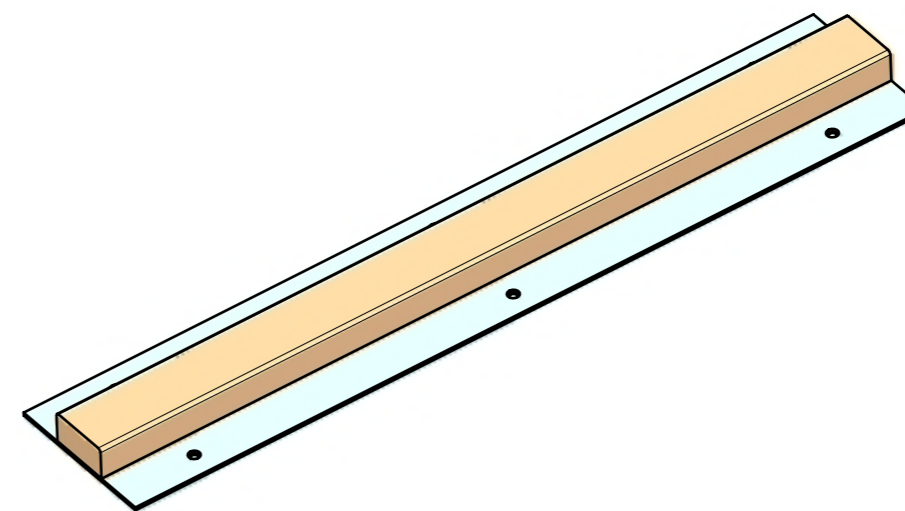

LOCALE	CODICE	DESCRIZIONE COMPONENTE	FINITURA	GR.
PORTE	MD321_MF_P03	PORTA CABINA VIP		PTP

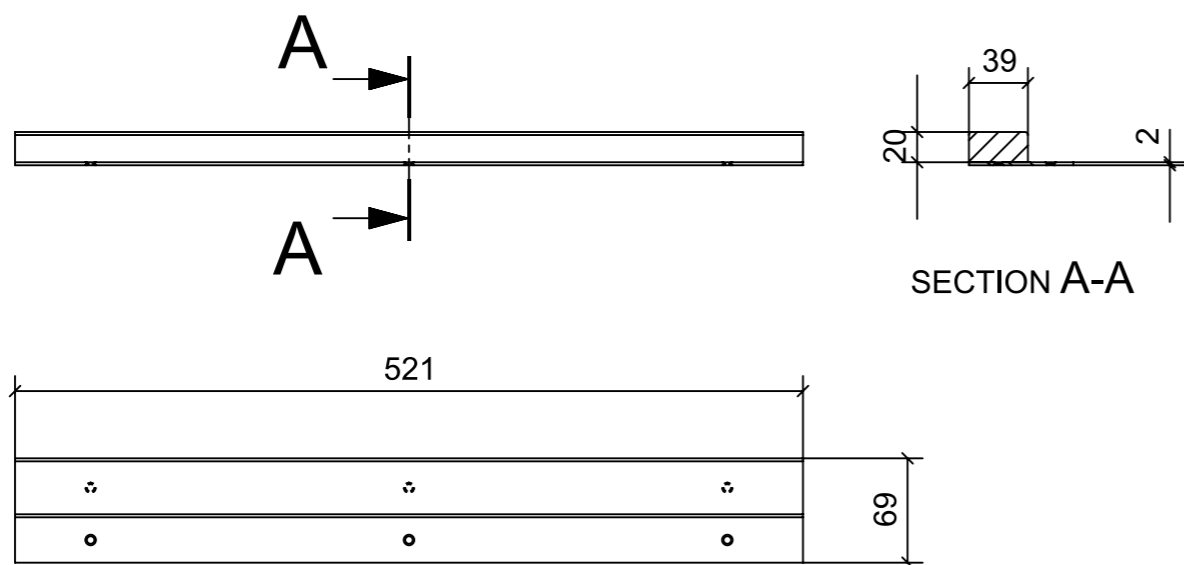

MF\_P03

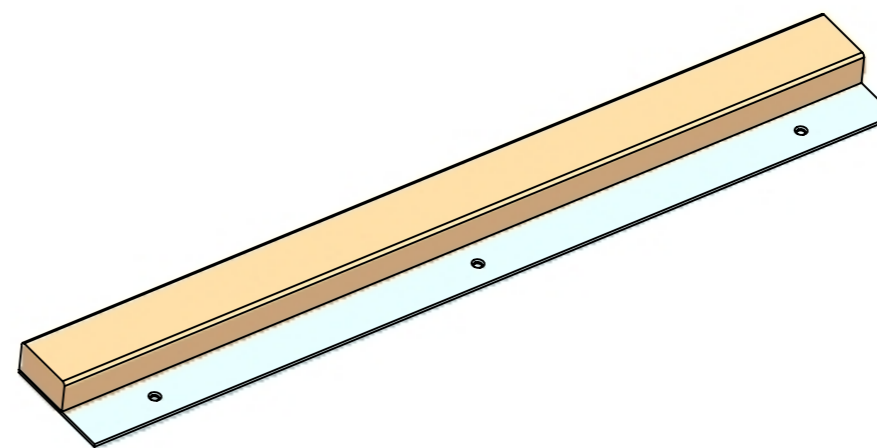
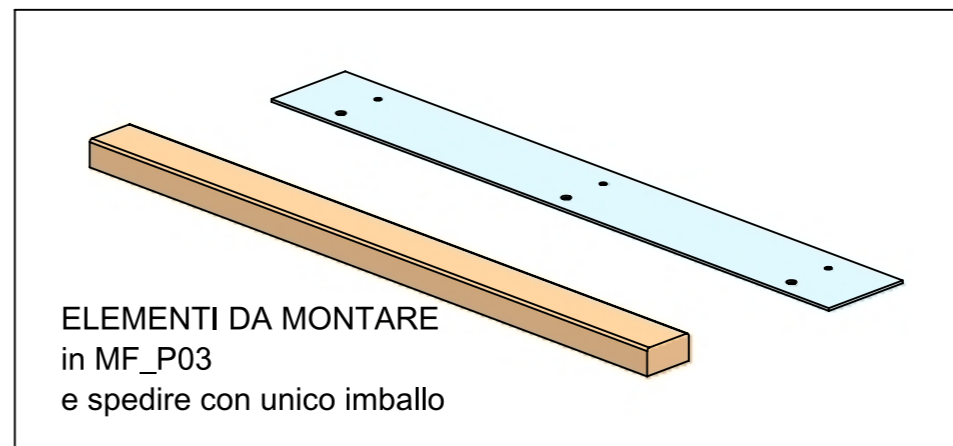

LOCALE	CODICE	DESCRIZIONE COMPONENTE	FINITURA	GR.
PORTE	MD321_MF_P04	PORTA BAGNO OSPITI DA CORRIDOIO		PTP

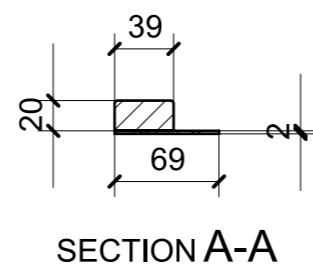
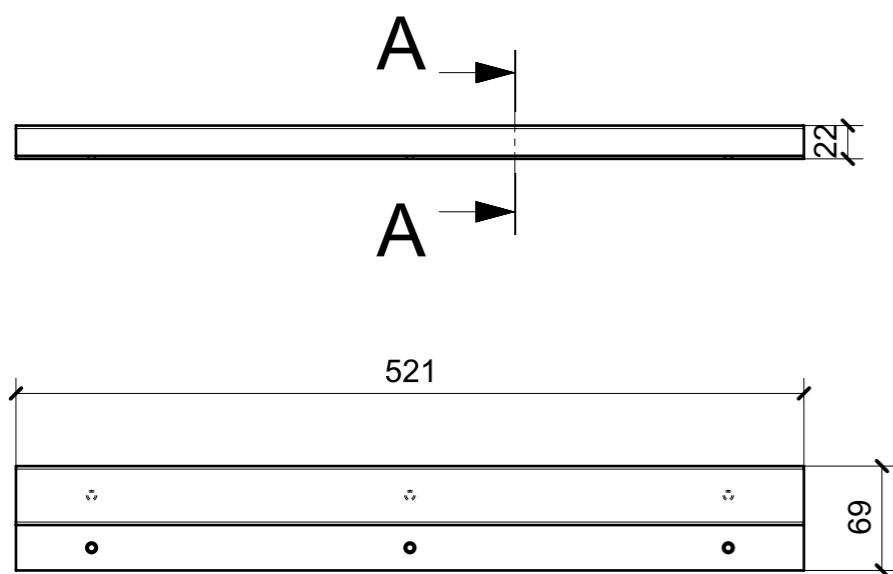

ELEMENTI DA MONTARE  
in MF\_P04  
e spedire con unico imballo

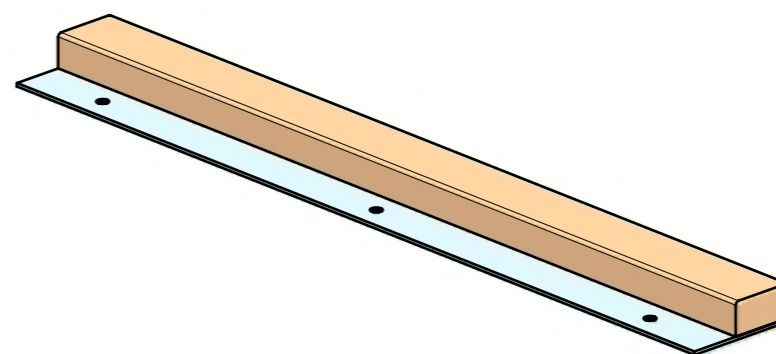
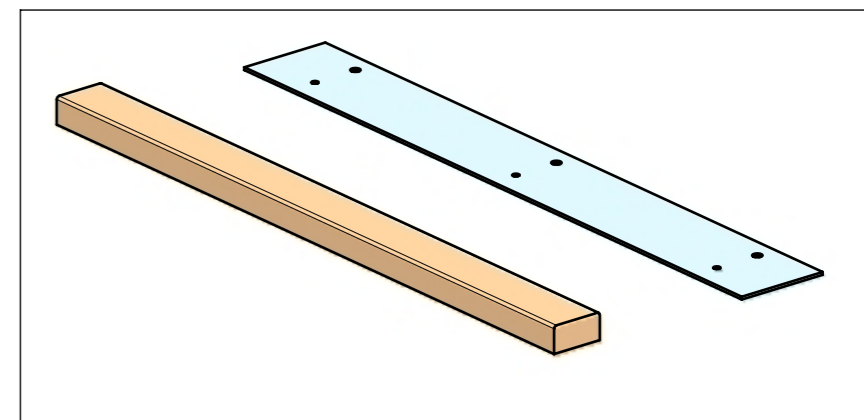

MF\_P04

LOCALE	CODICE	DESCRIZIONE COMPONENTE	FINITURA	GR.
PORTE	MD321_MF_P05	PORTA CABINA OSPITI DX		PTP

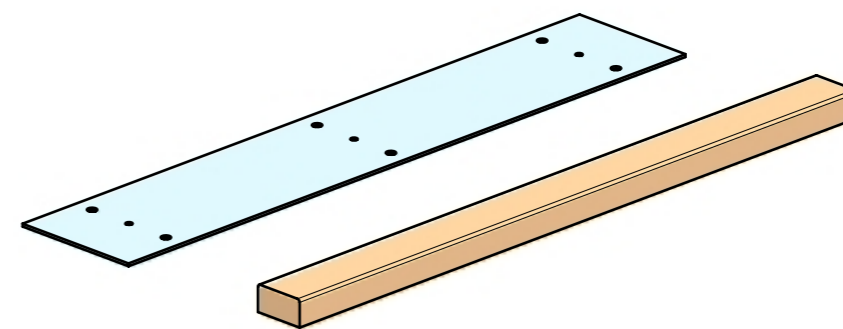
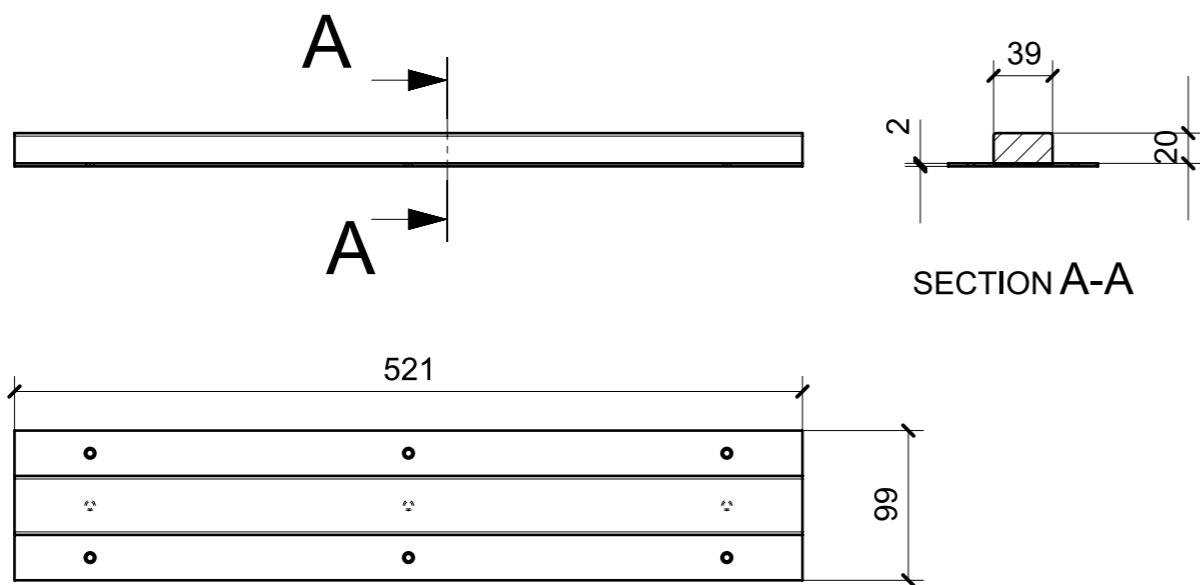

ELEMENTI DA MONTARE  
in MF\_P05  
e spedire con unico imballo

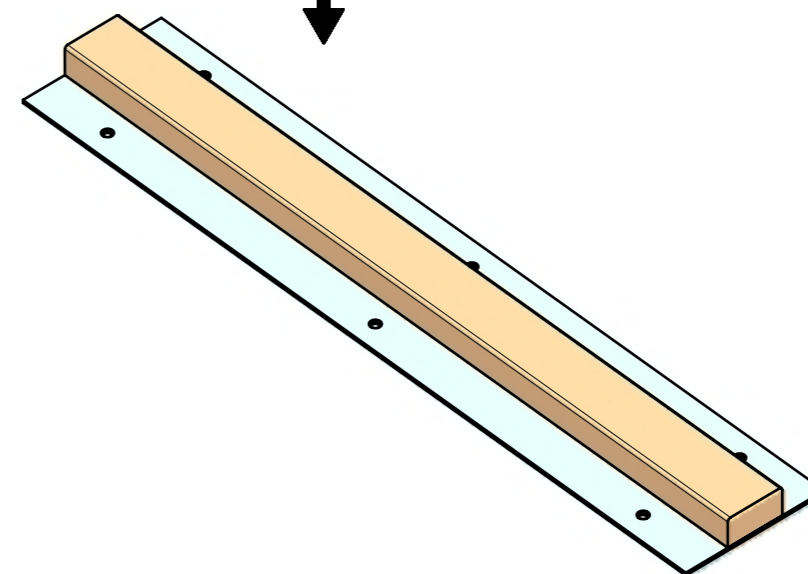

MF\_P05

LOCALE	CODICE	DESCRIZIONE COMPONENTE	FINITURA	GR.
PORTE	MD321_MF_P06	PORTA CABINA OSPITI SX		PTP

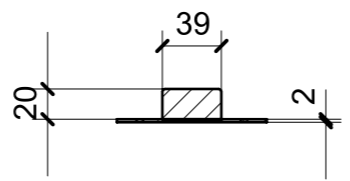
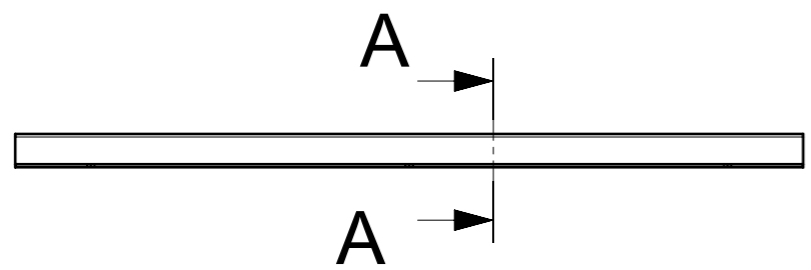

SECTION A-A

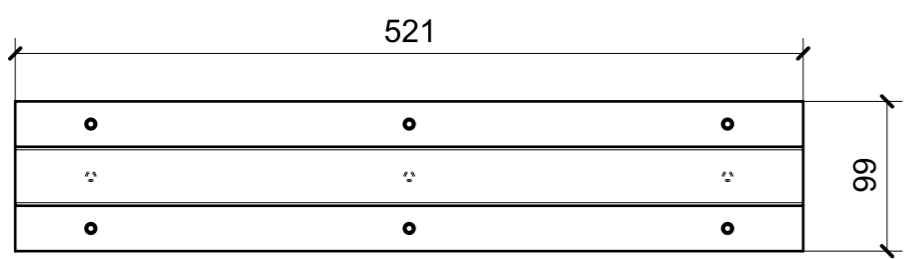

MF\_P06

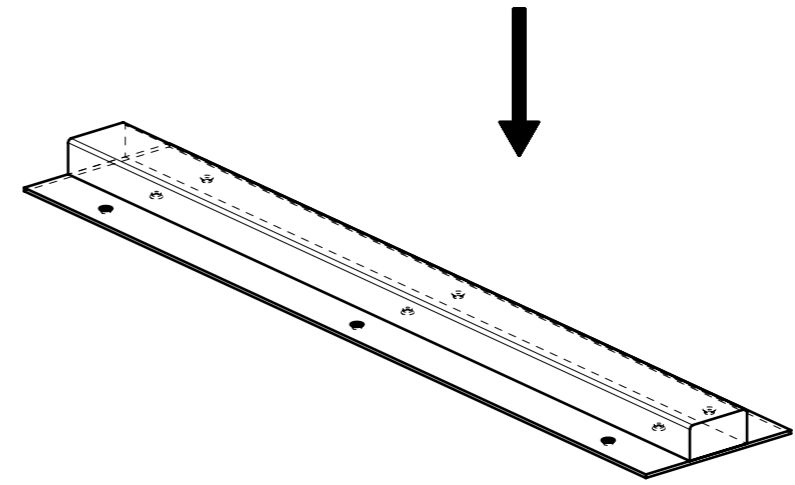
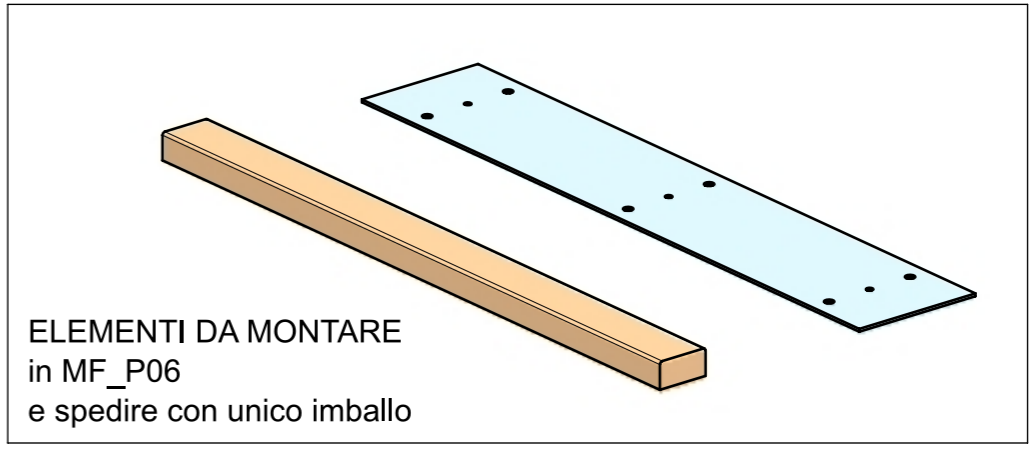

LOCALE	CODICE	DESCRIZIONE COMPONENTE	FINITURA	GR.
PORTE	MD321_MF_P07	PORTA CABINA ARMATORE		2

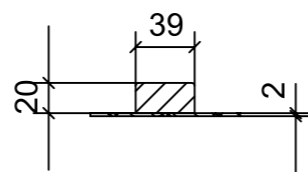
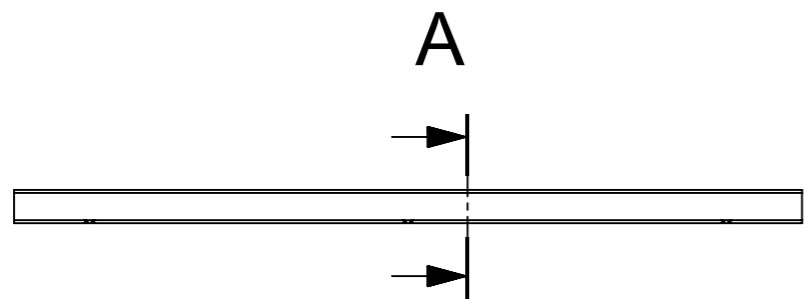

SECTION A-A

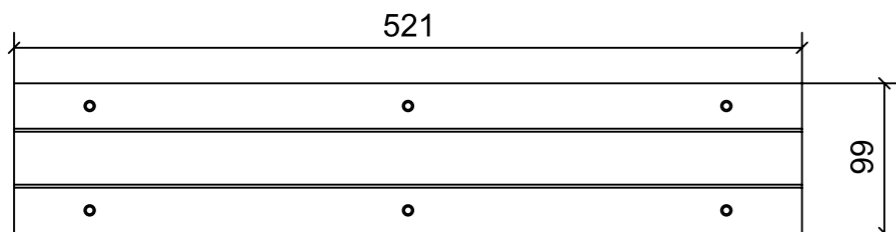

MF\_P07

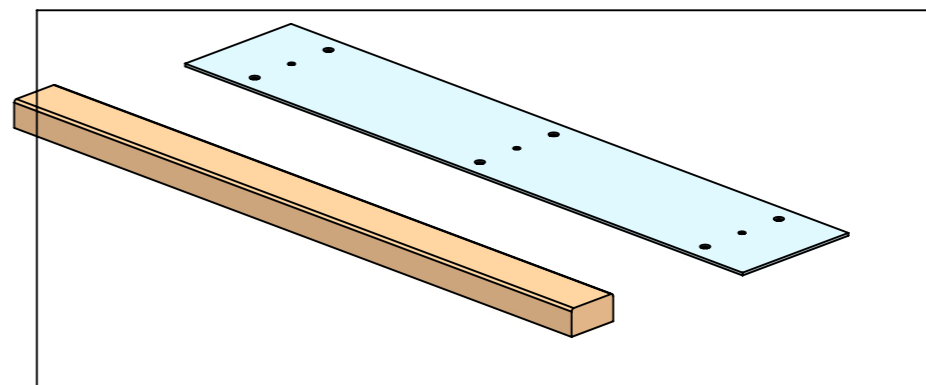

ELEMENTI DA MONTARE  
in MF\_P07  
e spedire con unico imballo

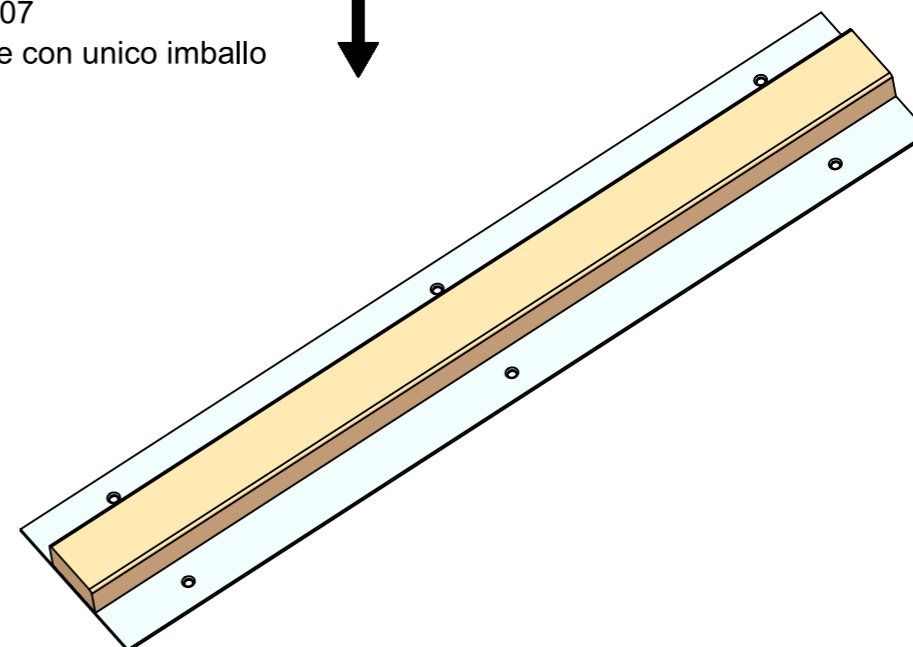

LOCALE	CODICE	DESCRIZIONE COMPONENTE	FINITURA	GR.
PORTE	MD321_MF_P08	PORTA BAGNO ARMATORE		PTP

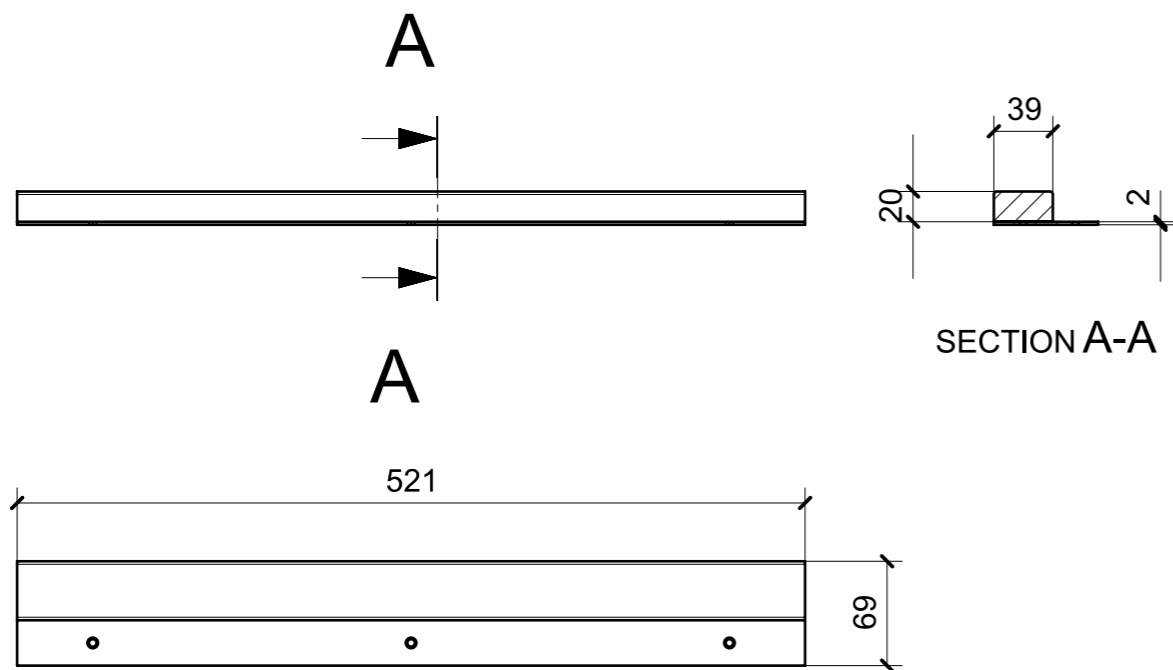

MF\_P08

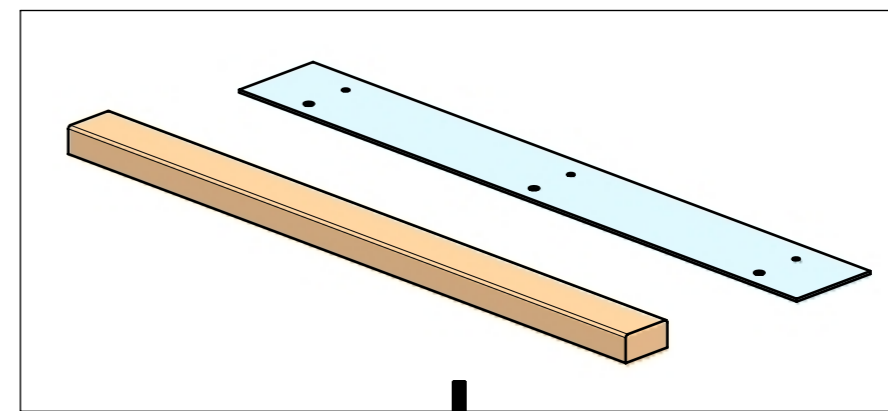

ELEMENTI DA MONTARE  
in MF\_P08  
e spedire con unico imballo

