

LOCALE	CODICE	DESCRIZIONE COMPONENTE	FINITURA	GR.
CABINA ARMATORE	MD321_R01_AA01	ARMADIO	LASTRA ALPI JAY STRIPED 12.35	PTP

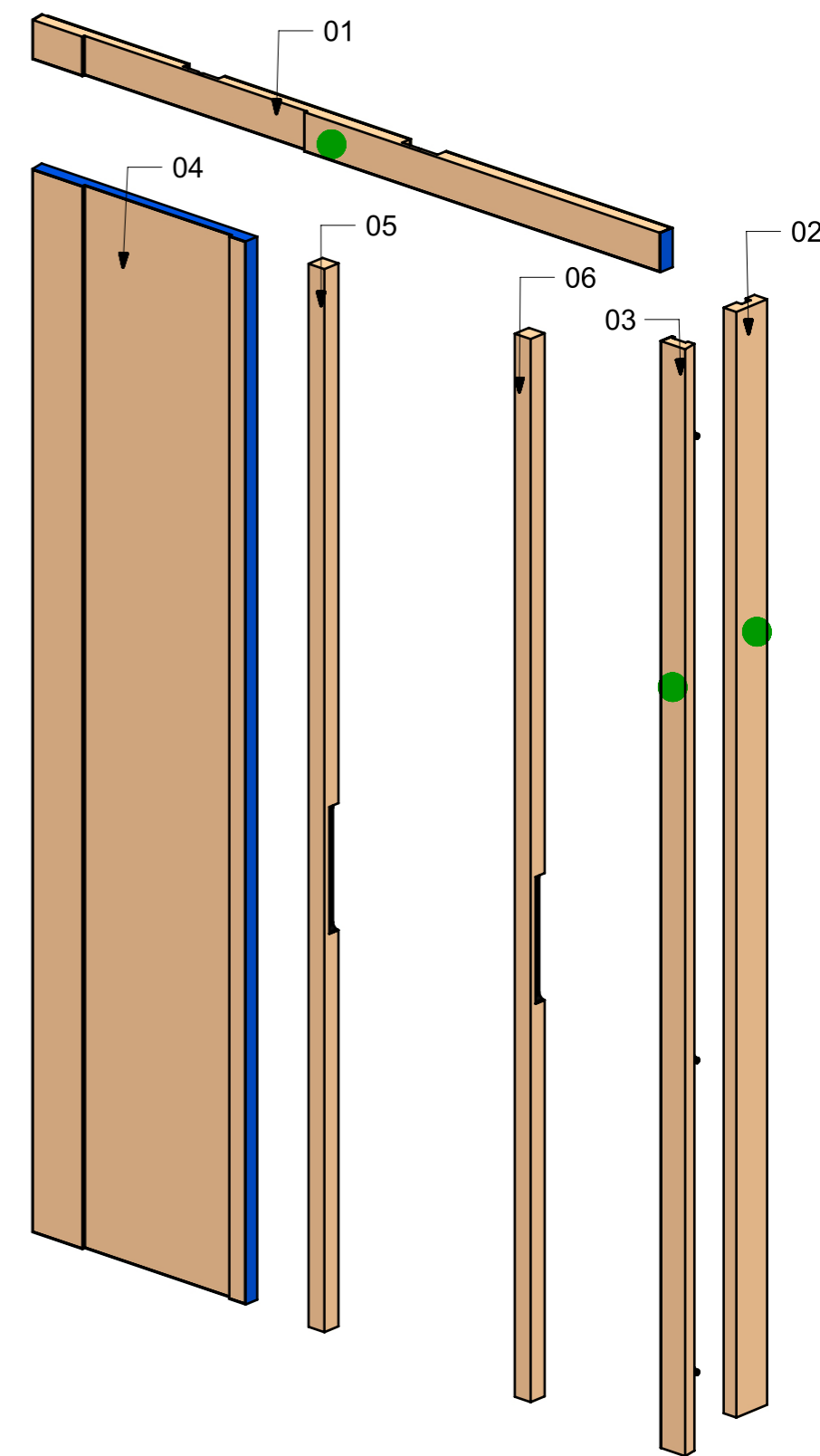
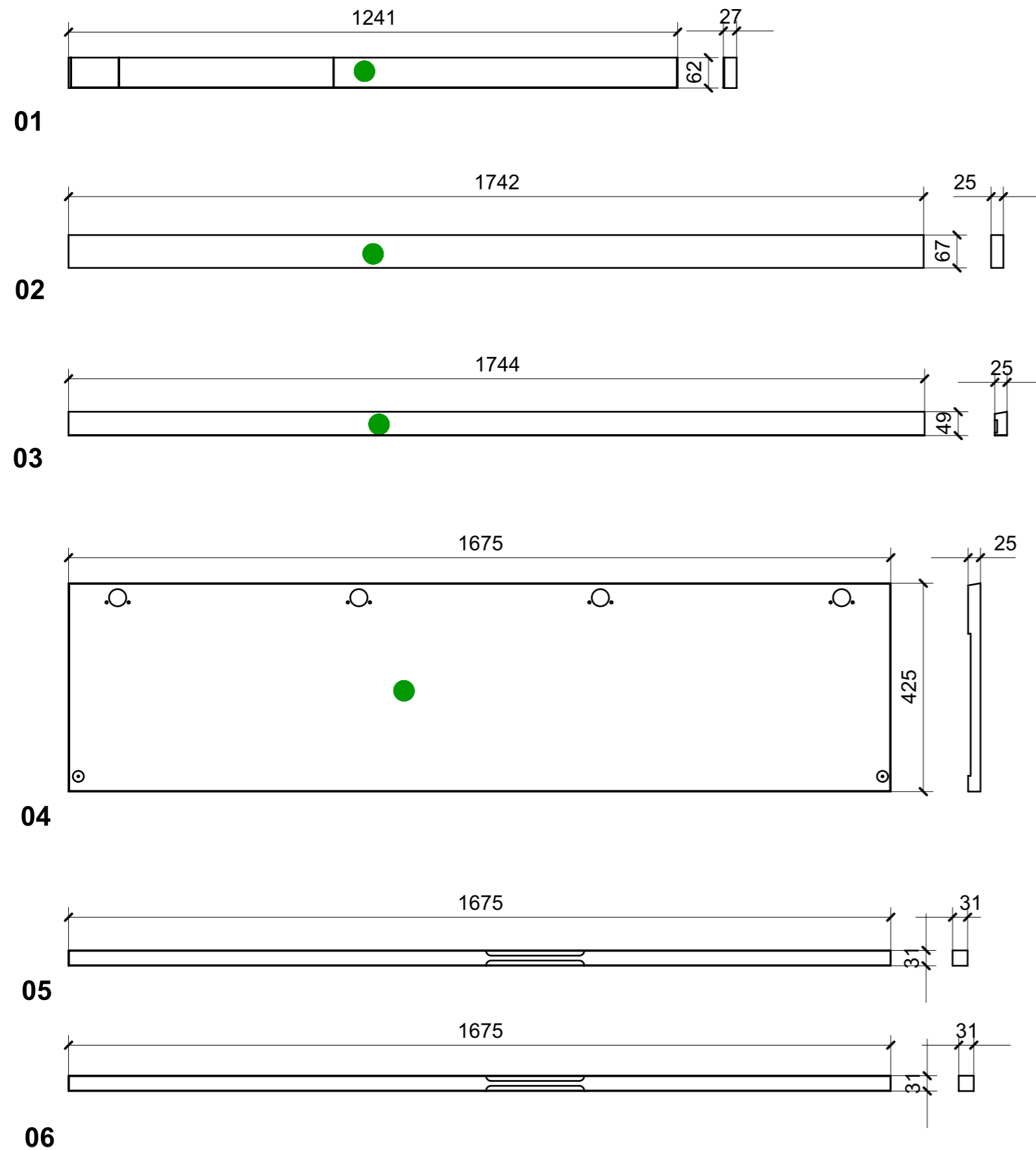

FERRAMENTA	QTY
SENSORE RETROANTA_HAFELE_833_89_334	2
BUSSOLA 6MA X 10 FORO DIAM.8	3
MAGNETE FORZA MAGNETICA1-5 10KG_HAFELE_246.87.112	2
BUSSOLA 5MA ANKOR BORGHI X CERNIERA COLLO PIENO	8

VERNICIATURA LASTRA/LACCATI:

● = VERNICIARE 1 LATO + FILI RASATI O BORDATI

NESSUN SIMBOLO = VERNICIARE 2 LATI + FILI RASATI O BORDATI

LOCALE	CODICE	DESCRIZIONE COMPONENTE	FINITURA	GR.
CABINA ARMATORE	MD321_R02_AA01	ARMADIO	LASTRA ALPI JAY FLAMED 12.34	PTP

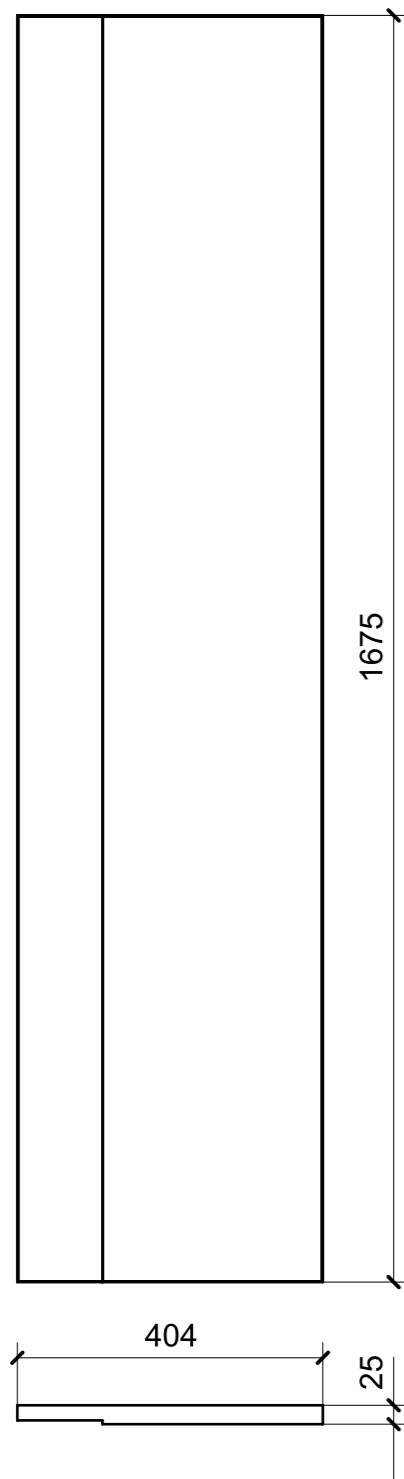

01

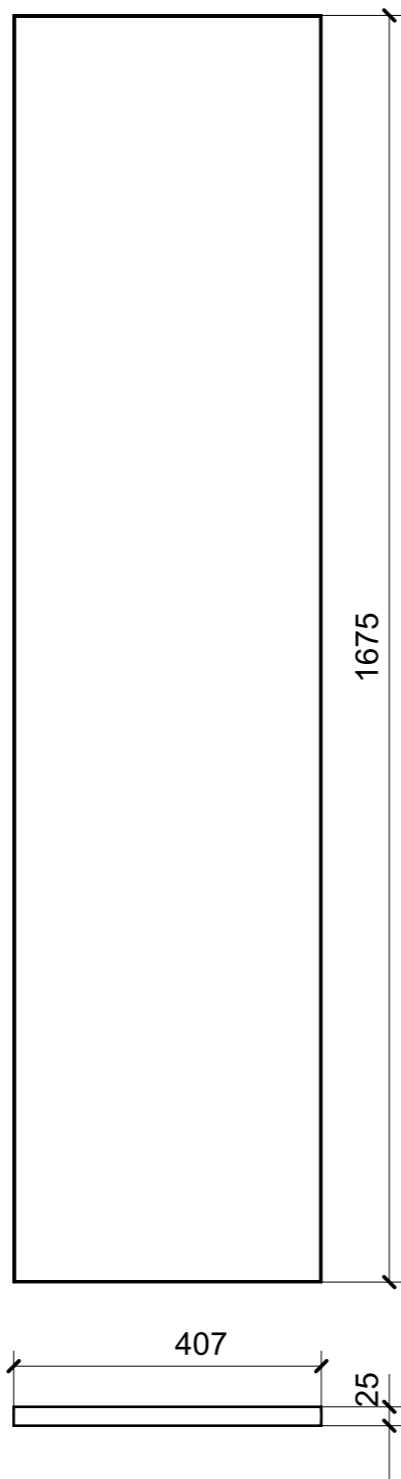

02

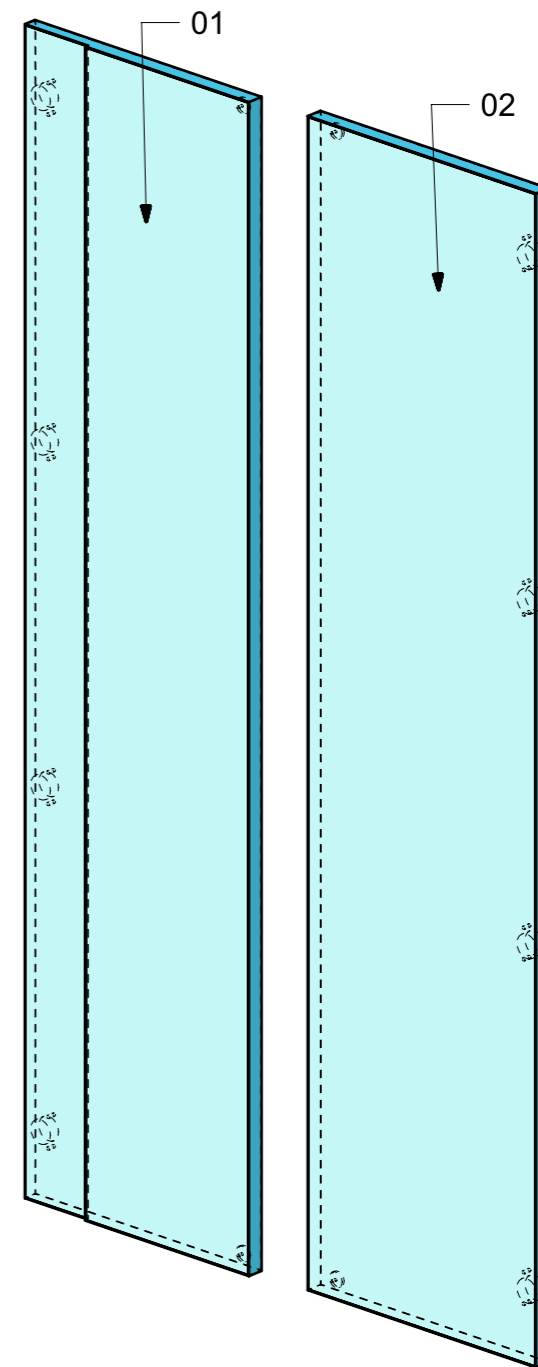

FERRAMENTA	QTY
MAGNETE FORZA MAGNETICA1-5 10KG_HAFELE_246.87.112	4
BUSSOLA 5MA ANKOR BORGHI X CERNIERA COLLO PIENO	16

VERNICIATURA LASTRA/LACCATI:

● = VERNICIARE 1 LATO + FILI RASATI O BORDATI

NESSUN SIMBOLO = VERNICIARE 2 LATI + FILI RASATI O BORDATI

LOCALE	CODICE	DESCRIZIONE COMPONENTE	FINITURA	GR.
CABINA ARMATORE	MD321_R01_AB01	STRUTTURA DX VANO TENDA	LASTRA ALPI JAY STRIPED 12.35	2

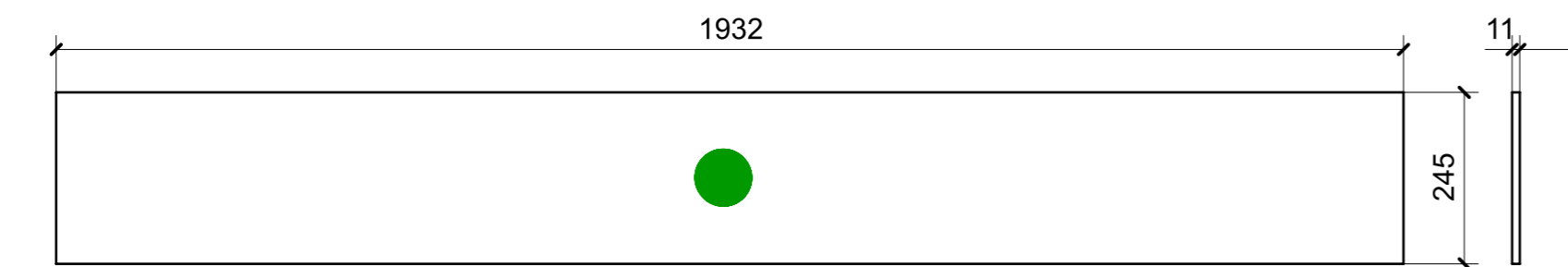

01

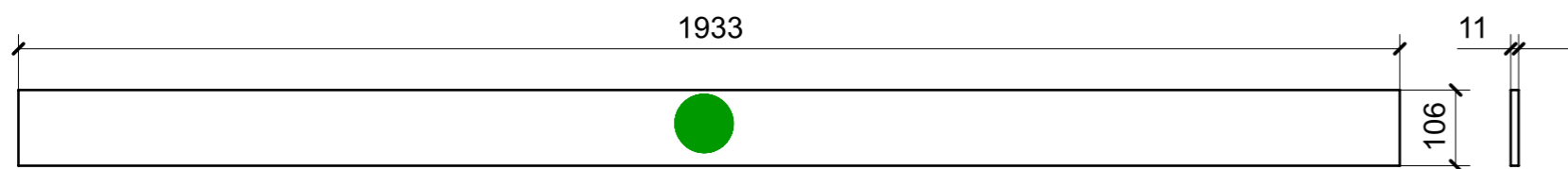

02

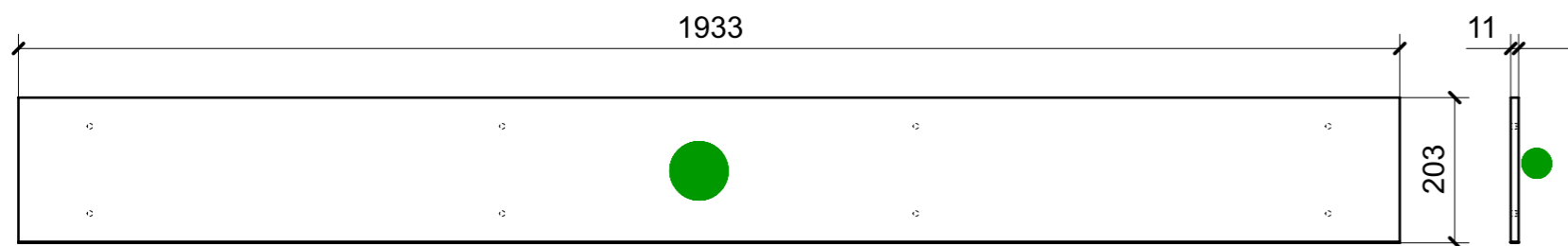

03

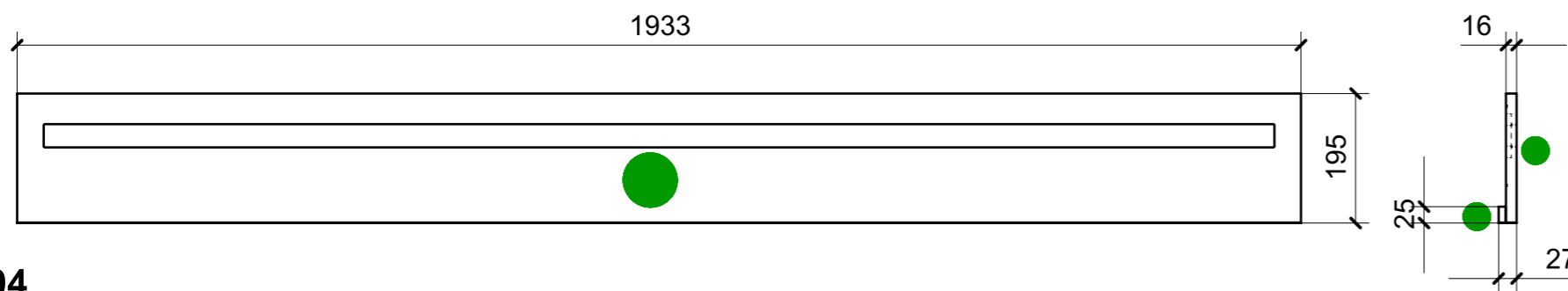

04

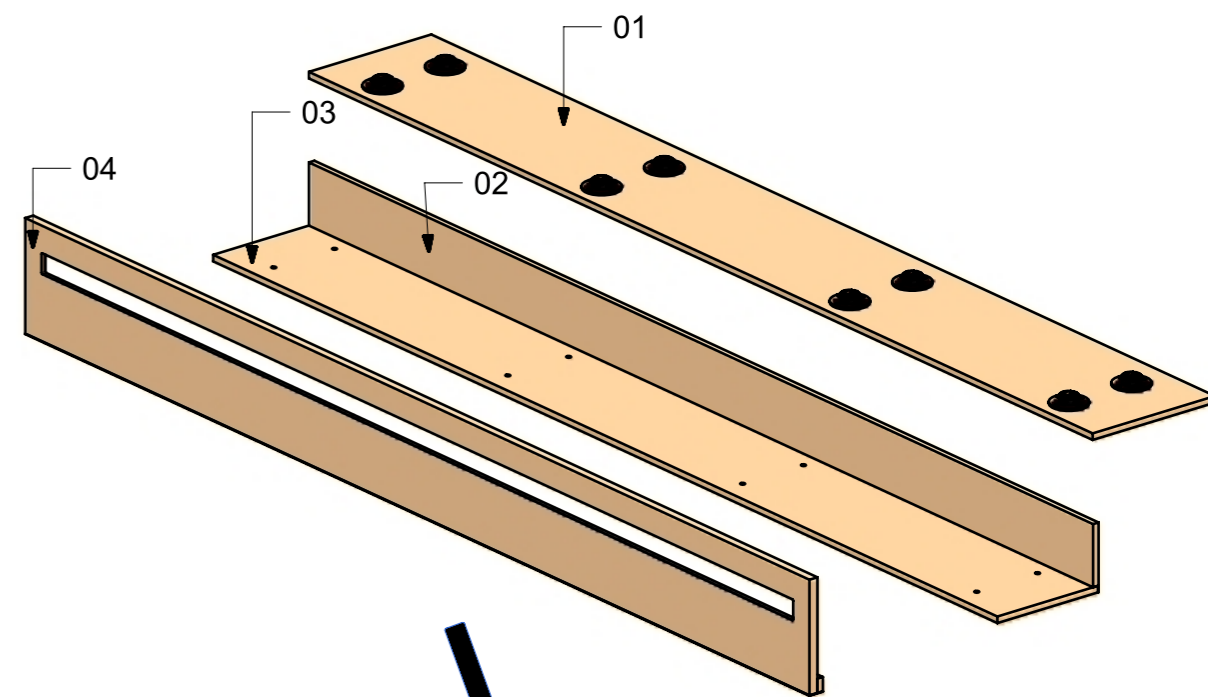

ELEMENTI DA MONTARE
in MF_AB01
e spedire in unico imballo

FERRAMENTA	QTY
FITLOCK M_MASCHERPA_3MM_6020202101	8

VERNICIATURA LASTRA/LACCATI:

● = VERNICIARE 1 LATO + FILI RASATI O BORDATI

NESSUN SIMBOLO = VERNICIARE 2 LATI + FILI RASATI O BORDATI

LOCALE	CODICE	DESCRIZIONE COMPONENTE	FINITURA	GR.
CABINA ARMATORE	MD321_R01_AD01	STRUTTURA MURATA DX	LASTRA ALPI JAY STRIPED 12.35	PTP

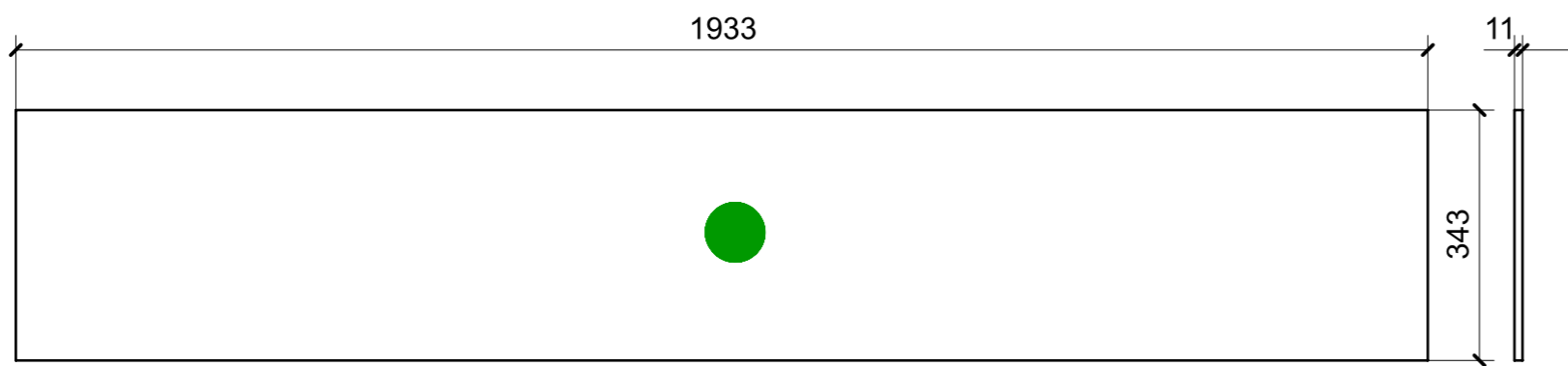

01

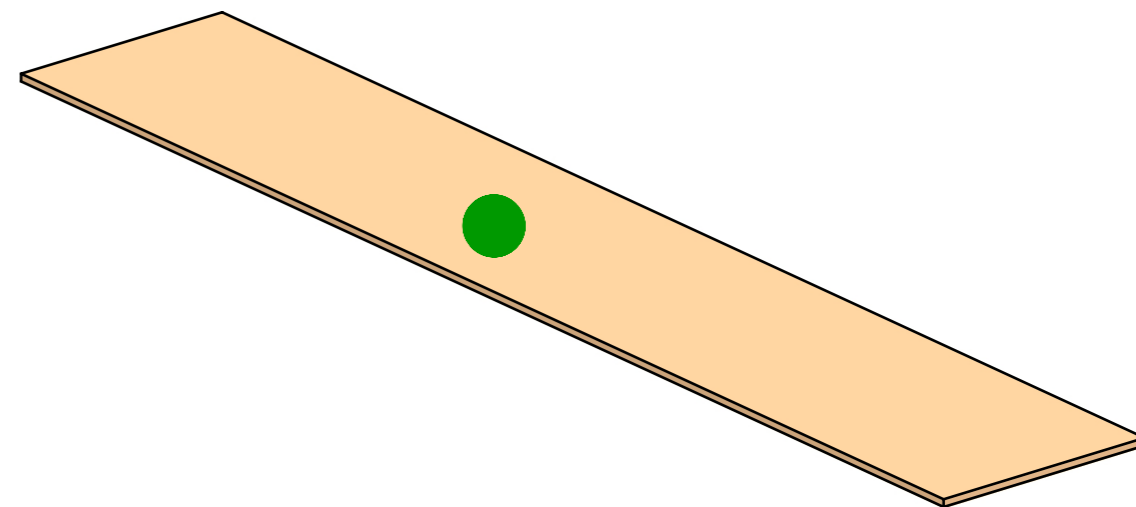

VERNICIATURA LASTRA/LACCATI:

● = VERNICIARE 1 LATO + FILI RASATI O BORDATI

NESSUN SIMBOLO = VERNICIARE 2 LATI + FILI RASATI O BORDATI

LOCALE	CODICE	DESCRIZIONE COMPONENTE	FINITURA	GR.
CABINA ARMATORE	MD321_R02_AD01	STRUTTURA MURATA DX	LASTRA ALPI JAY FLAMED 12.34	PTP

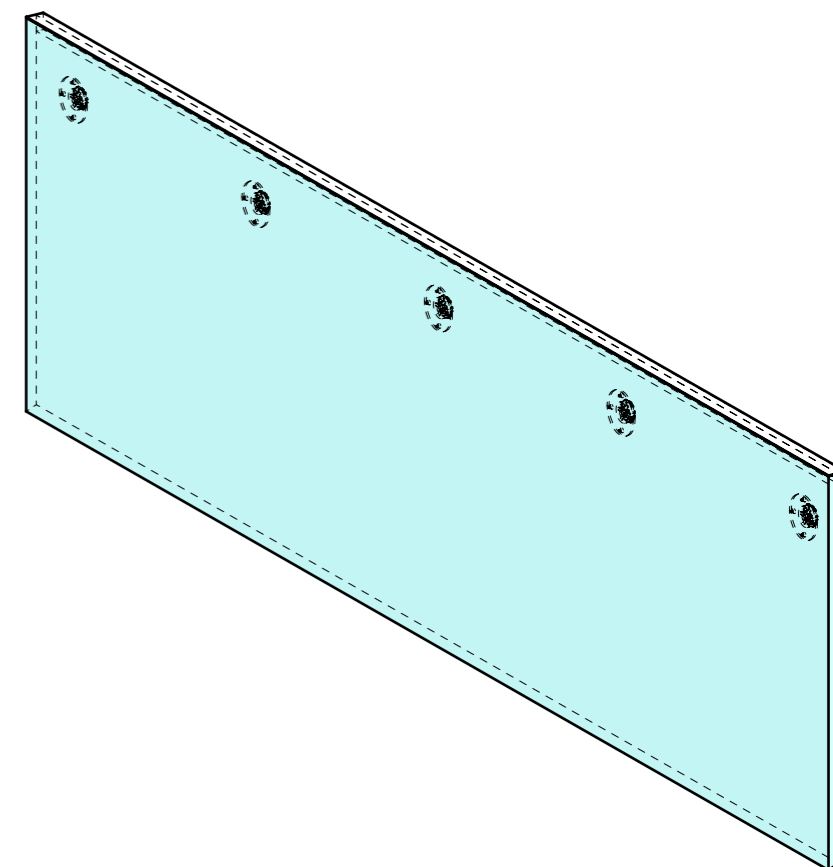
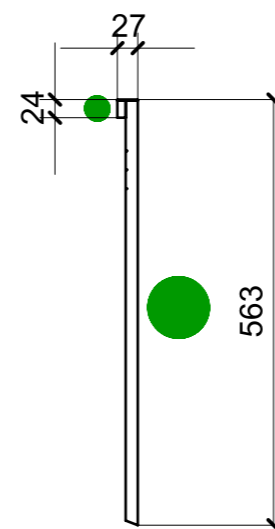
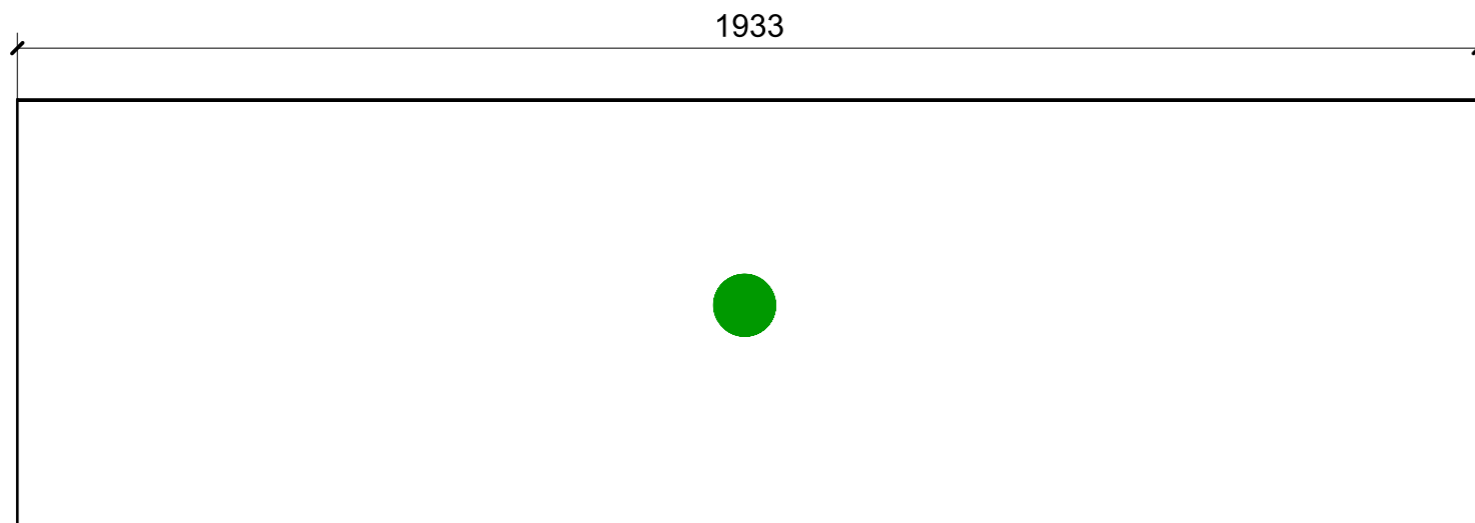

01

FERRAMENTA	QTY
FITLOCK M_MASCHERPA_3MM_6020202101	5

VERNICIATURA LASTRA/LACCATI:

● = VERNICIARE 1 LATO + FILI RASATI O BORDATI

NESSUN SIMBOLO = VERNICIARE 2 LATI + FILI RASATI O BORDATI

LOCALE	CODICE	DESCRIZIONE COMPONENTE	FINITURA	GR.
CABINA ARMATORE	MD321_R01_AF01	RIV. GRADINO MURATA DX	LASTRA ALPI JAY STRIPED 12.35	2

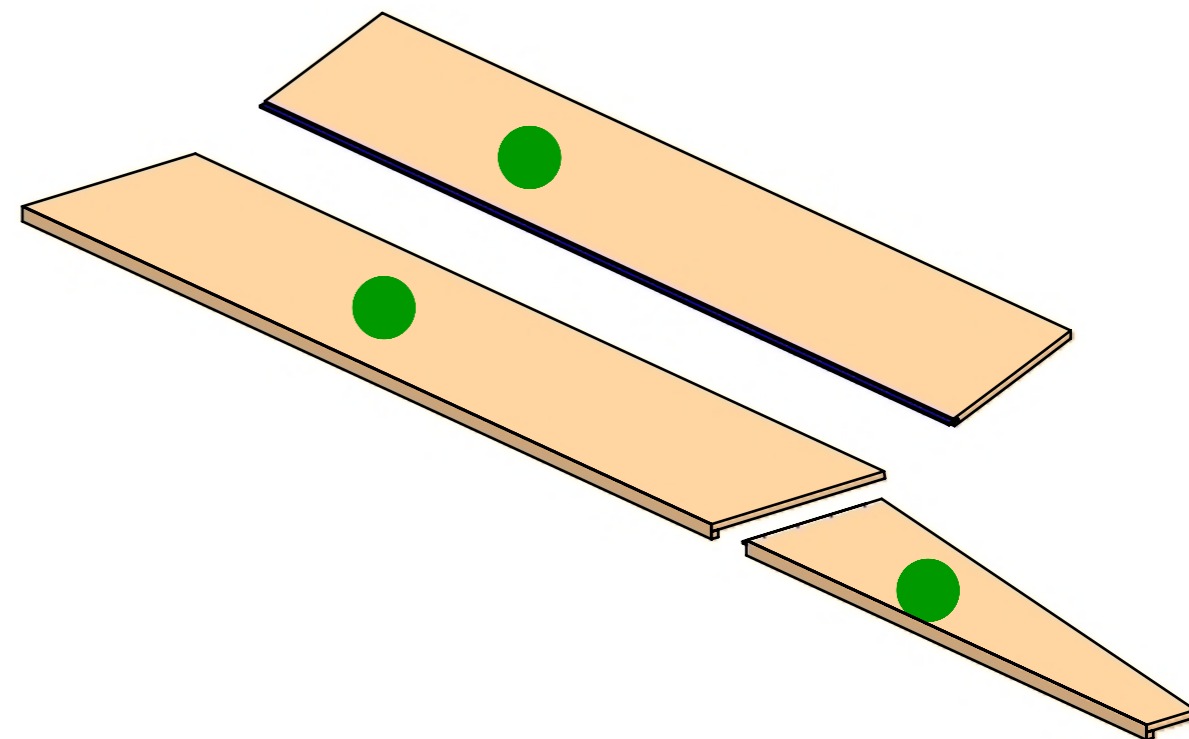
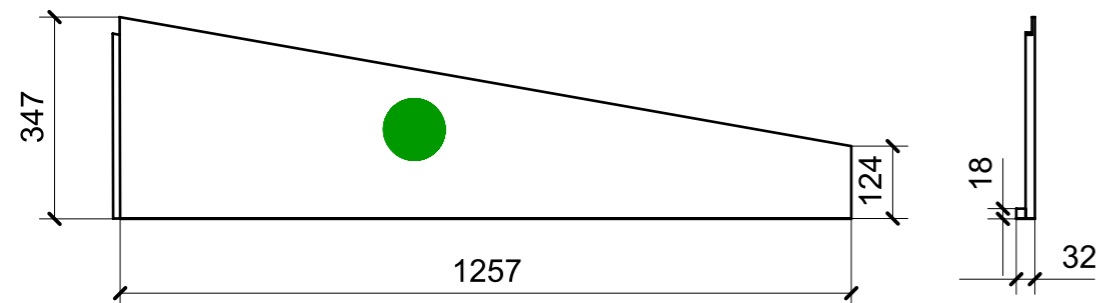
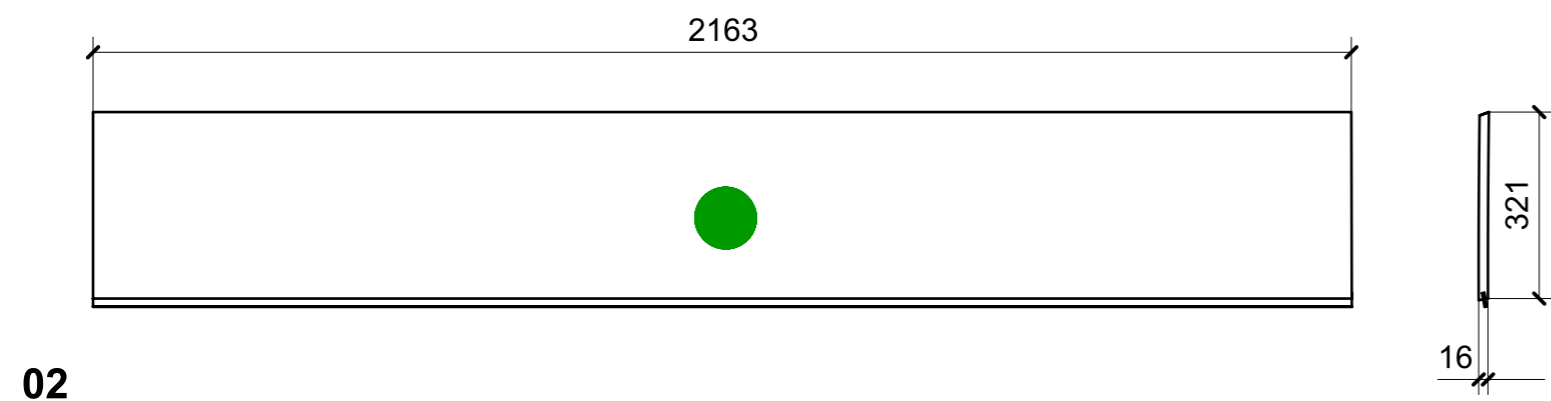
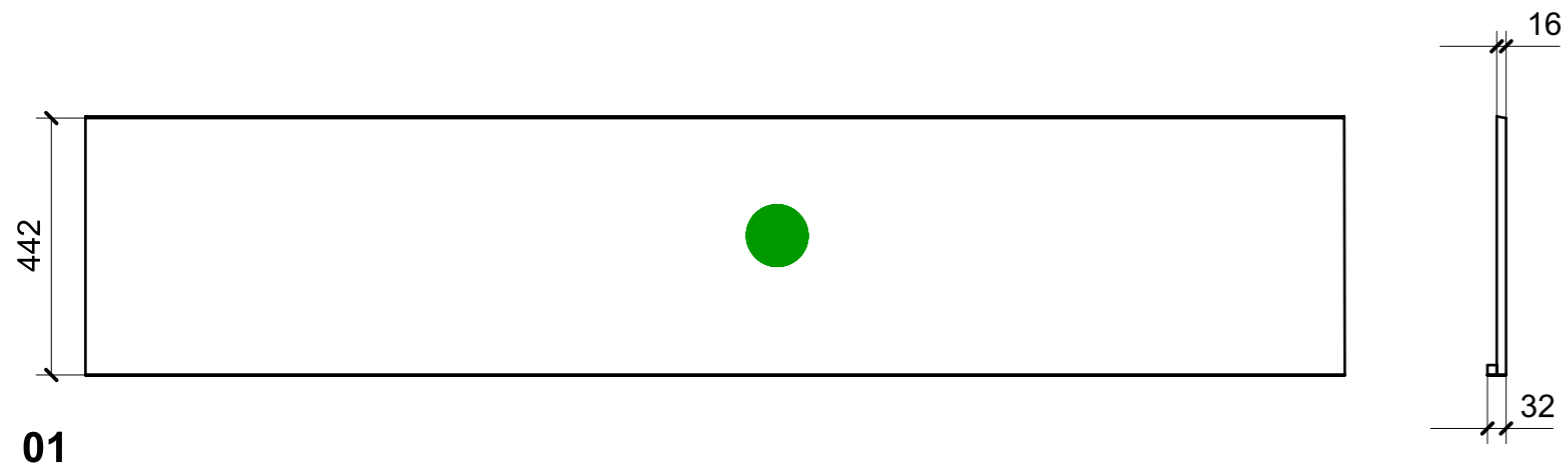

VERNICIATURA LASTRA/LACCATI:

● = VERNICIARE 1 LATO + FILI RASATI O BORDATI

NESSUN SIMBOLO = VERNICIARE 2 LATI + FILI RASATI O BORDATI

LOCALE	CODICE	DESCRIZIONE COMPONENTE	FINITURA	GR.
CABINA ARMATORE	MD321_R01_AG01	MOBILE A RIBALTA POPPA DX	LASTRA ALPI JAY STRIPED 12.35	2

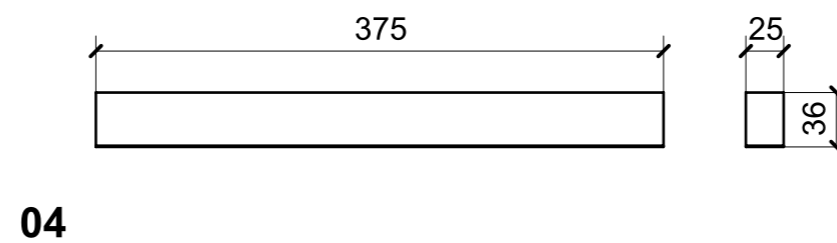
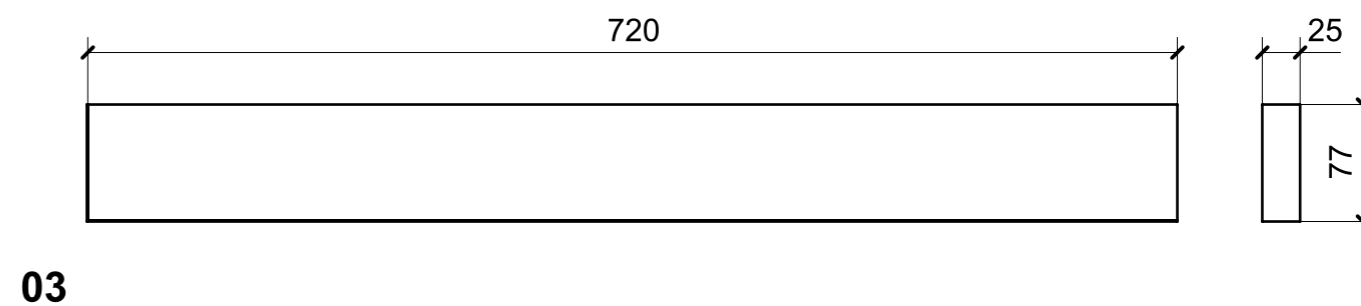
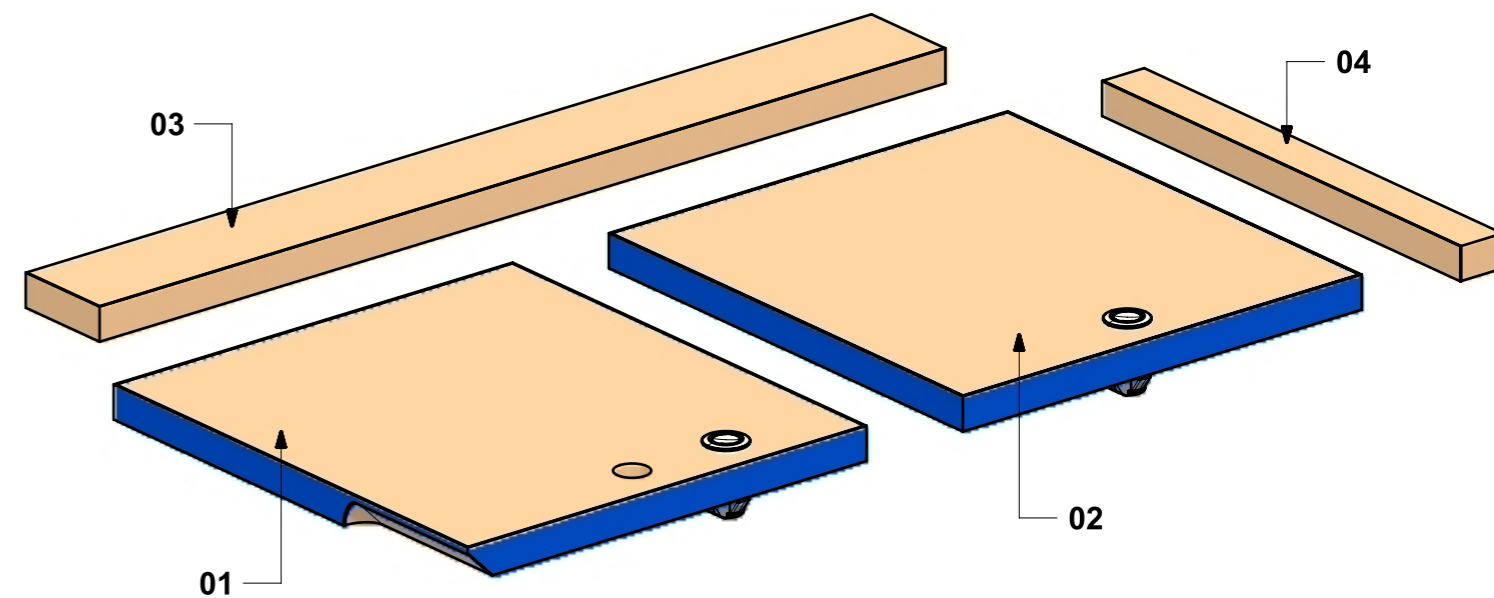
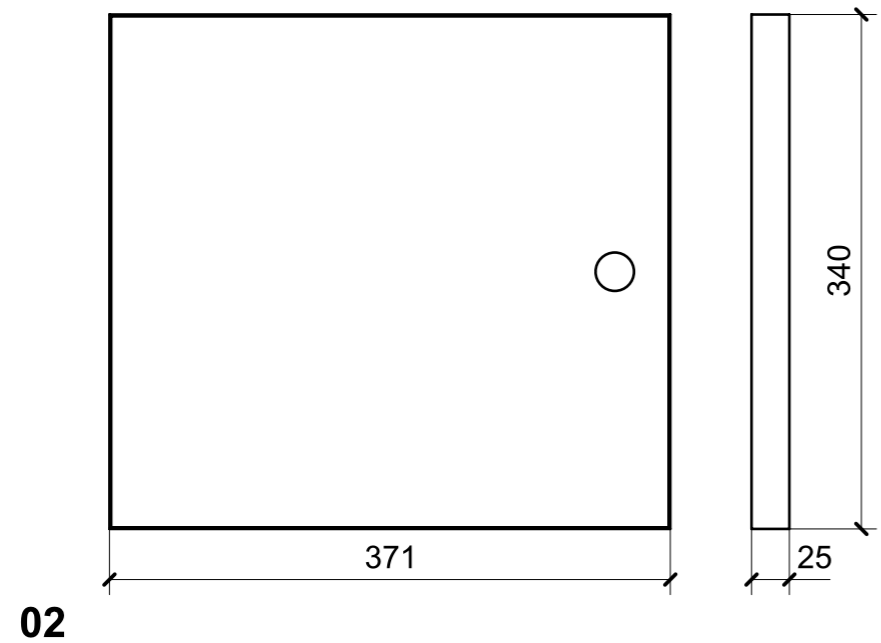
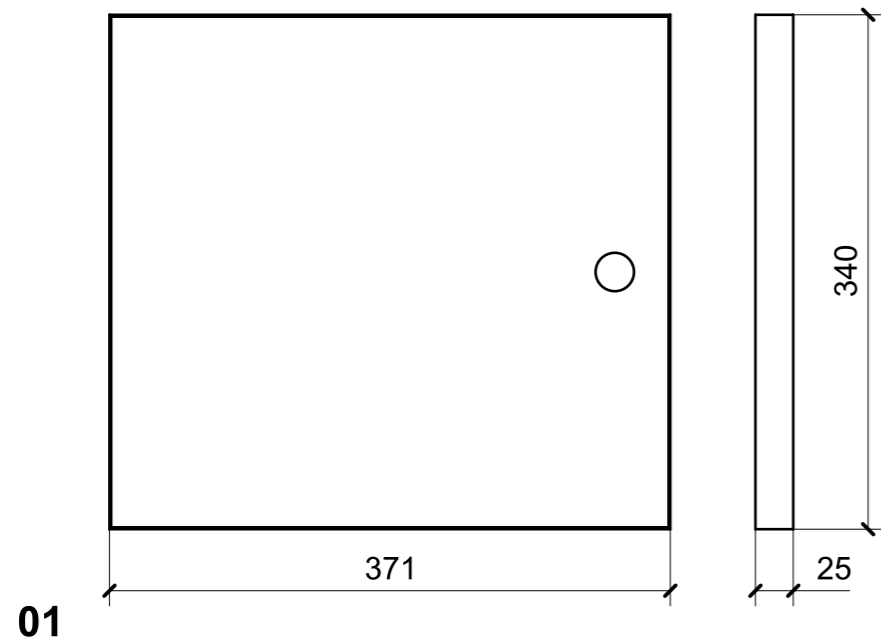

FERRAMENTA	QTY
PUSH TO CLOSE_ SOUTHCO-MP-05-312-55 NERA_ TECHNOPARTNER	2
BUSSOLA 5MA ANKOR BORGHI X CERNIERA COLLO PIENO	8

VERNICIATURA LASTRA/LACCATI:

● = VERNICIARE 1 LATO + FILI RASATI O BORDATI

NESSUN SIMBOLO = VERNICIARE 2 LATI + FILI RASATI O BORDATI

LOCALE	CODICE	DESCRIZIONE COMPONENTE	FINITURA	GR.
CABINA ARMATORE	MD321_R02_AG01	MOBILE A RIBALTA POPPA DX	LASTRA ALPI JAY STRIPED 12.35	2

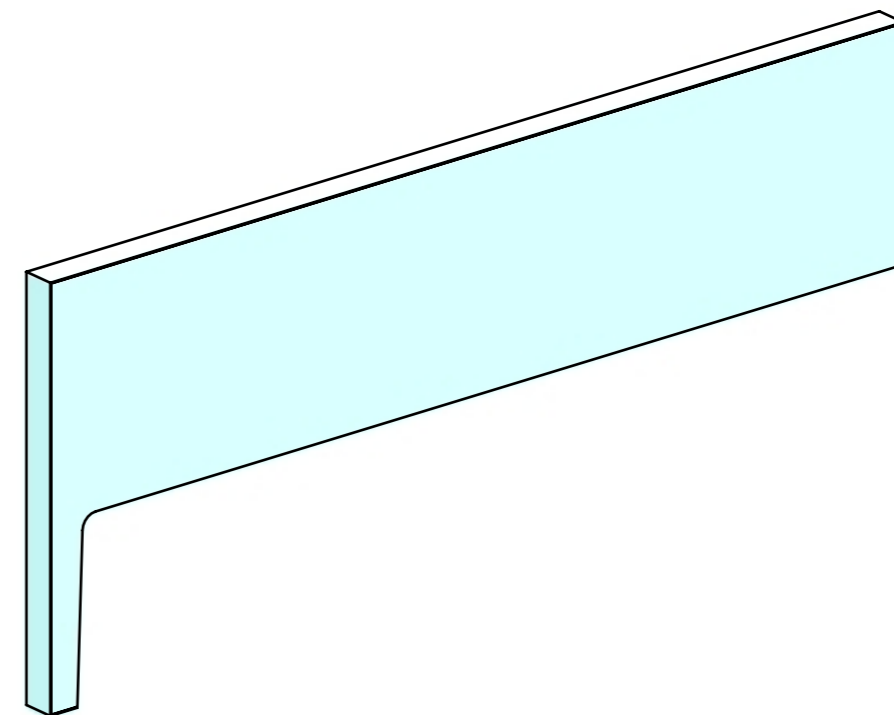
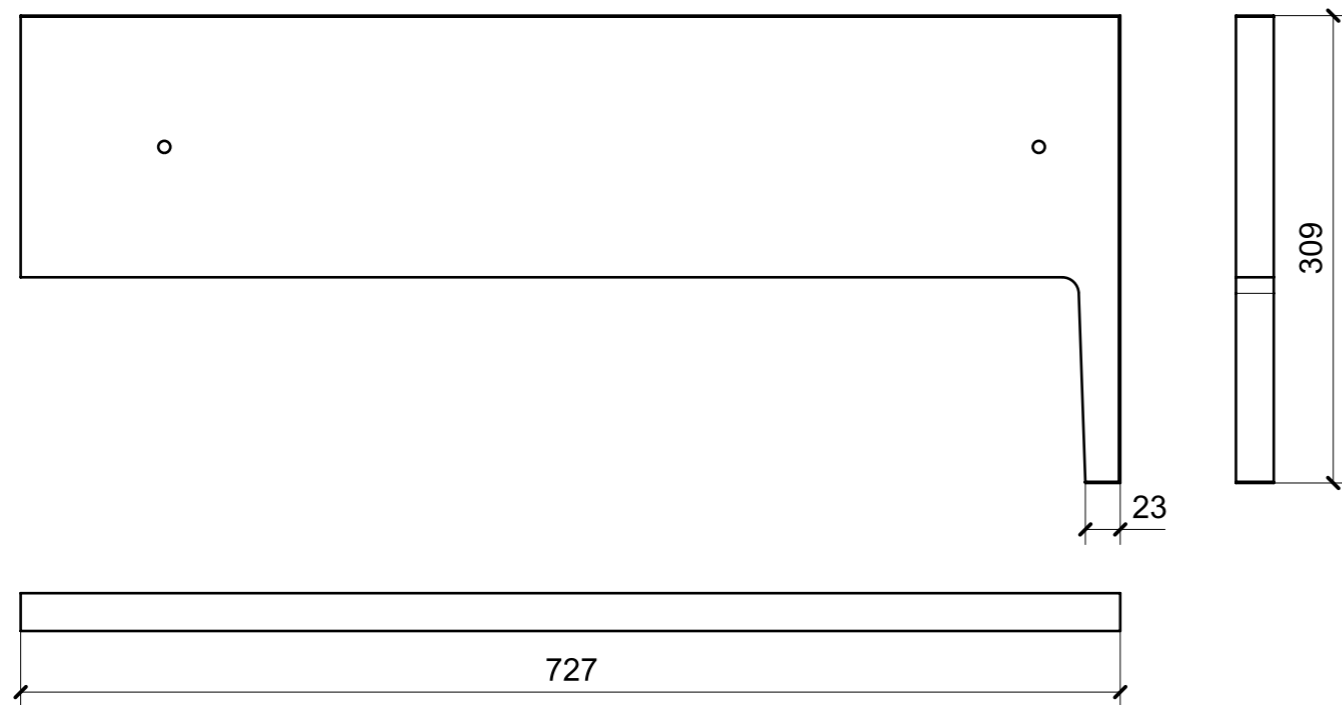

FERRAMENTA	QTY
BUSSOLA 6MA X 10 FORO DIAM.8	2

VERNICIATURA LASTRA/LACCATI:

● = VERNICIARE 1 LATO + FILI RASATI O BORDATI

NESSUN SIMBOLO = VERNICIARE 2 LATI + FILI RASATI O BORDATI

LOCALE	CODICE	DESCRIZIONE COMPONENTE	FINITURA	GR.
CABINA ARMATORE	MD321_R01_AH01	COMODINO DX	LASTRA ALPI JAY STRIPED 12.35	2

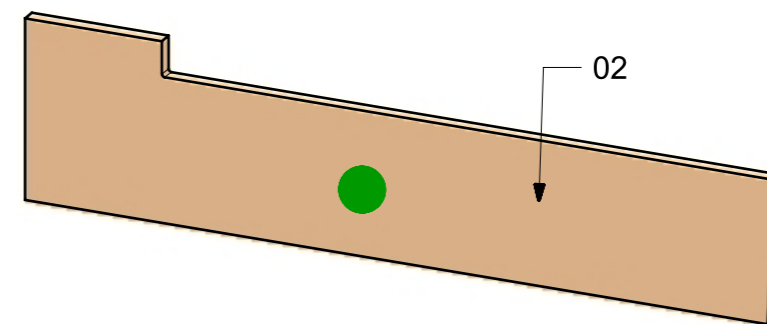
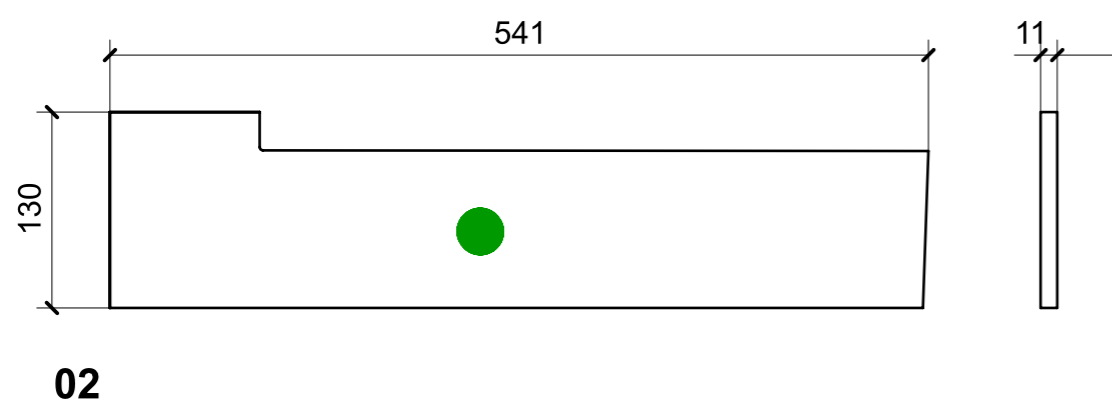
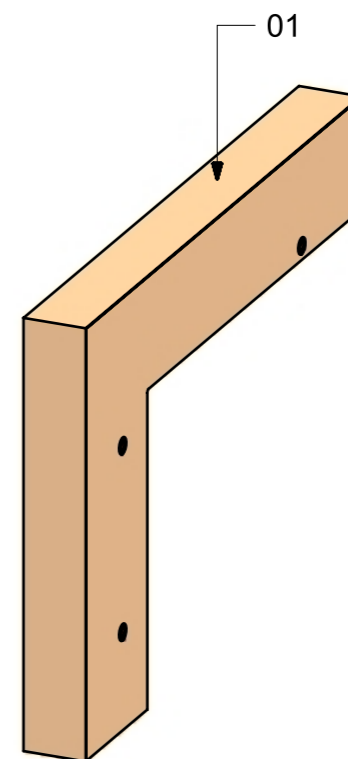
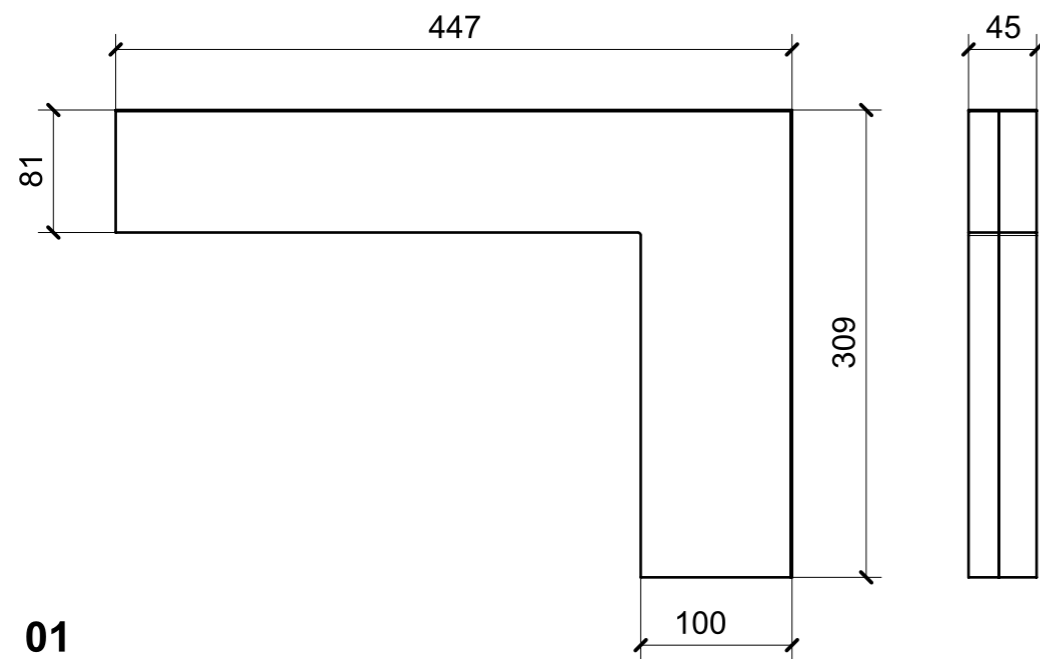

FERRAMENTA	QTY
BUSSOLA 6MA X 10 FORO DIAM.8	3

VERNICIATURA LASTRA/LACCATI:

● = VERNICIARE 1 LATO + FILI RASATI O BORDATI

NESSUN SIMBOLO = VERNICIARE 2 LATI + FILI RASATI O BORDATI

LOCALE	CODICE	DESCRIZIONE COMPONENTE	FINITURA	GR.
CABINA ARMATORE	MD321_R02_AH01	COMODINO DX	LASTRA ALPI JAY FLAMED 12.34	2

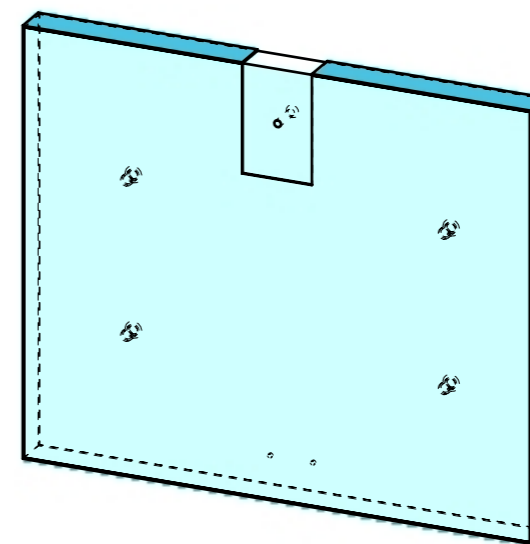
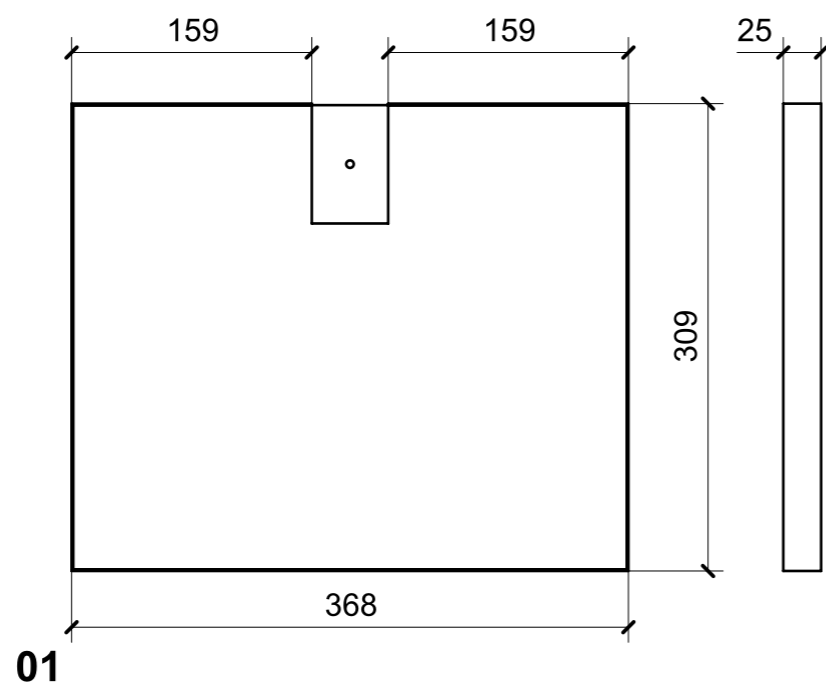

FERRAMENTA	QTY
BUSSOLA 6MA X 10 FORO DIAM.8	4

VERNICIATURA LASTRA/LACCATI:

● = VERNICIARE 1 LATO + FILI RASATI O BORDATI

NESSUN SIMBOLO = VERNICIARE 2 LATI + FILI RASATI O BORDATI

LOCALE	CODICE	DESCRIZIONE COMPONENTE	FINITURA	GR.
CABINA ARMATORE	MD321_R01_AI01	LETTO	LAISTRA ALPI JAY STRIPED 12.35	2

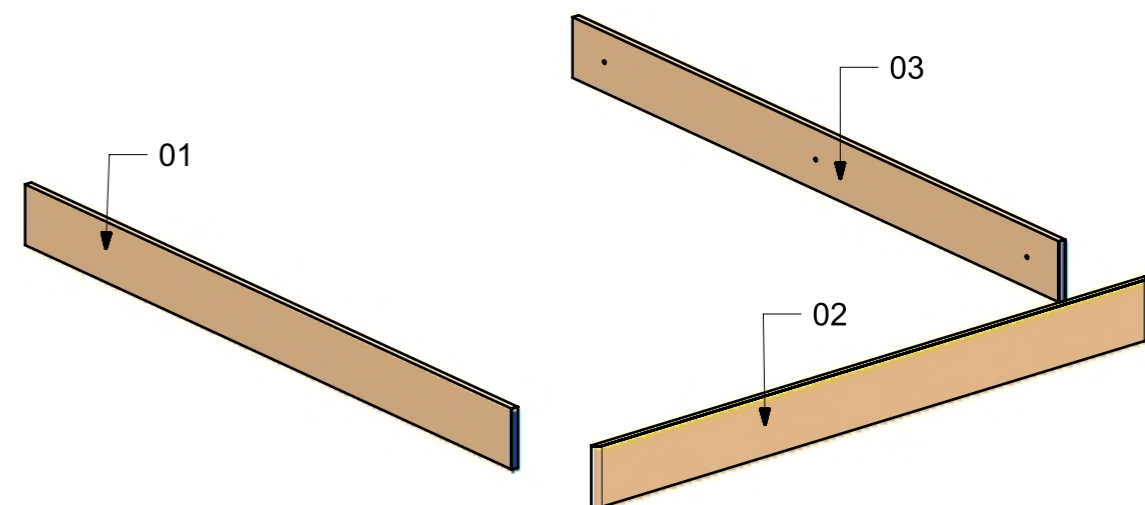
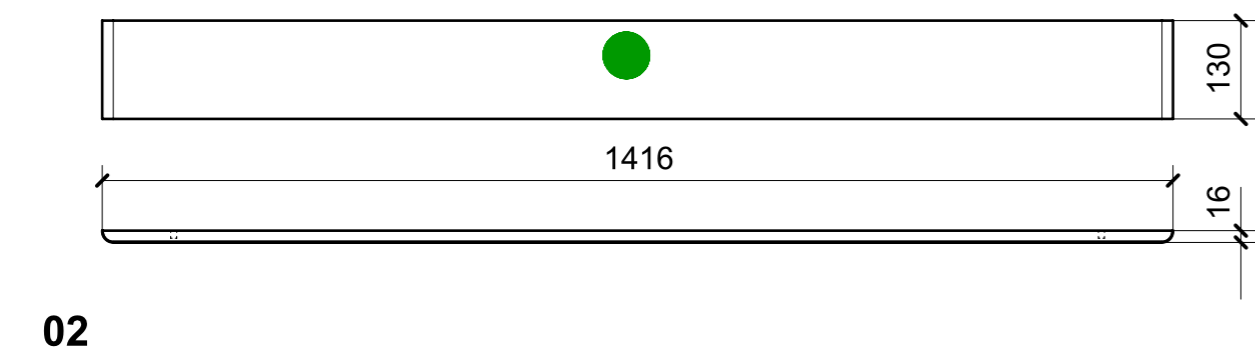
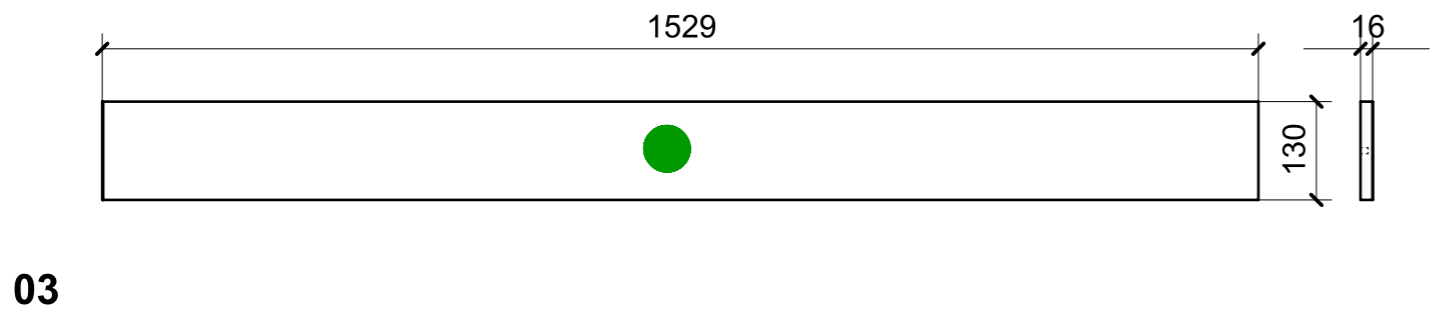
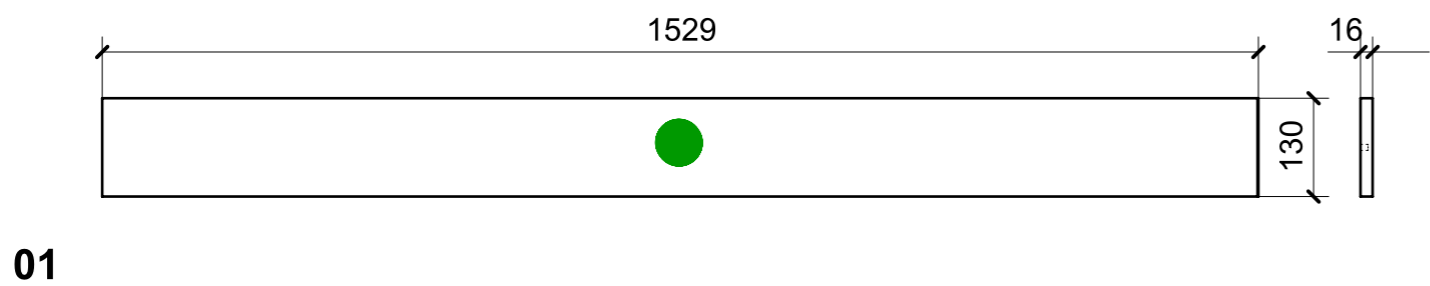

VERNICIATURA LASTRA/LACCATI:

● = VERNICIARE 1 LATO + FILI RASATI O BORDATI

NESSUN SIMBOLO = VERNICIARE 2 LATI + FILI RASATI O BORDATI

LOCALE	CODICE	DESCRIZIONE COMPONENTE	FINITURA	GR.
CABINA ARMATORE	MD321_R01_AJ01	COMODINO SX	LASTRA ALPI JAY STRIPED 12.35	2

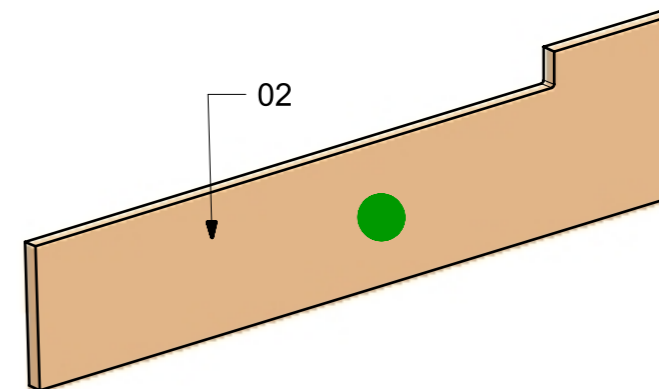
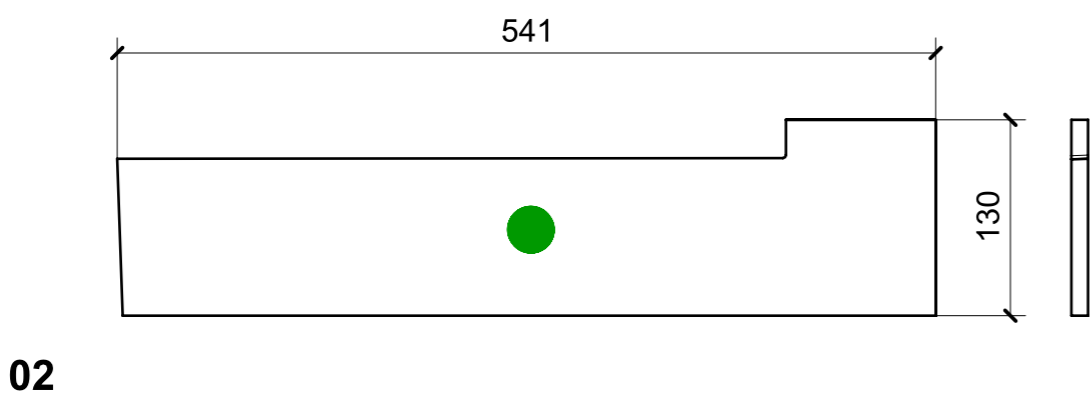
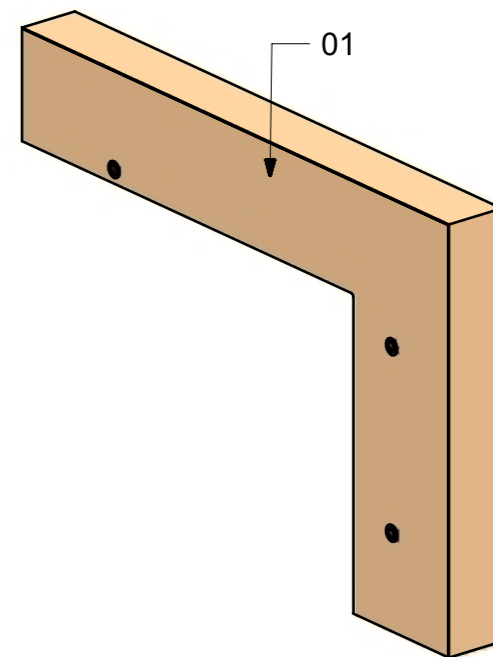
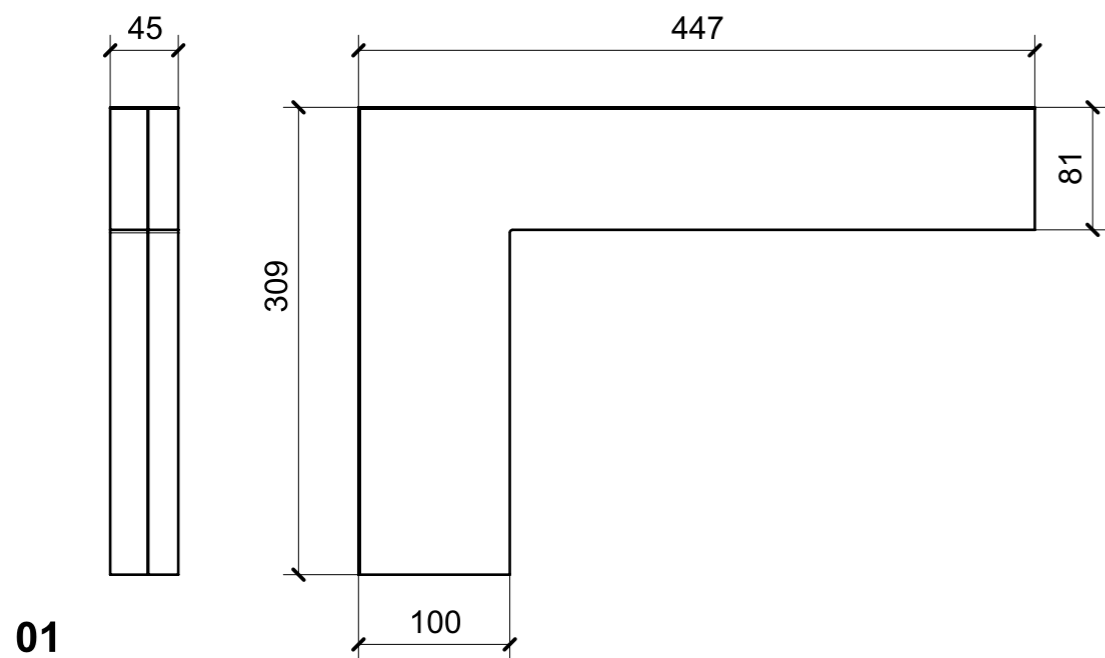

FERRAMENTA	QTY
BUSSOLA 6MA X 10 FORO DIAM.8	3

VERNICIATURA LASTRA/LACCATI:

● = VERNICIARE 1 LATO + FILI RASATI O BORDATI

NESSUN SIMBOLO = VERNICIARE 2 LATI + FILI RASATI O BORDATI

LOCALE	CODICE	DESCRIZIONE COMPONENTE	FINITURA	GR.
CABINA ARMATORE	MD321_R02_AJ01	COMODINO SX	LASTRA ALPI JAY FLAMED 12.34	2

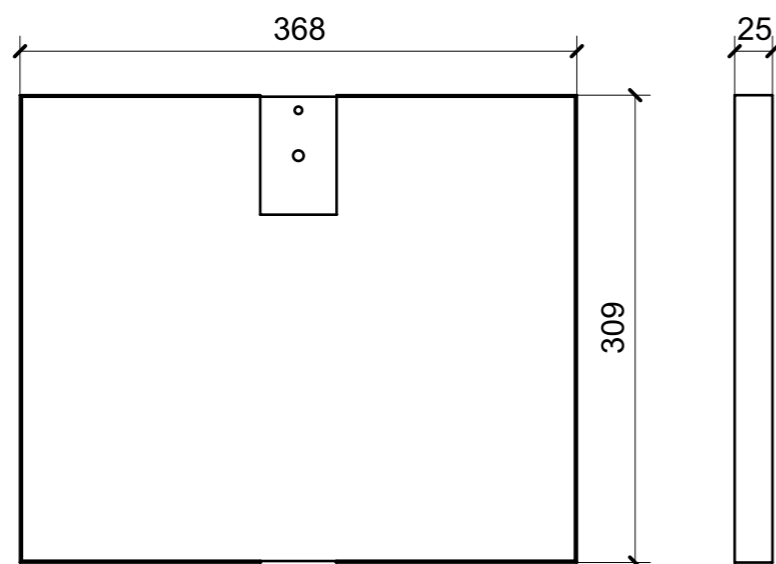

01

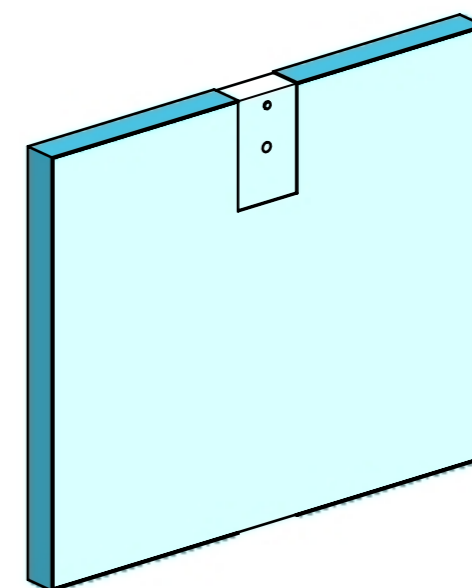

FERRAMENTA	QTY
BUSSOLA 6MA X 10 FORO DIAM.8	4

VERNICIATURA LASTRA/LACCATI:

● = VERNICIARE 1 LATO + FILI RASATI O BORDATI

NESSUN SIMBOLO = VERNICIARE 2 LATI + FILI RASATI O BORDATI

LOCALE	CODICE	DESCRIZIONE COMPONENTE	FINITURA	GR.
CABINA ARMATORE	MD321_R01_AK01	MOBILE A RIBALTA POPPA SX	LASTRA ALPI JAY STRIPED 12.35	2

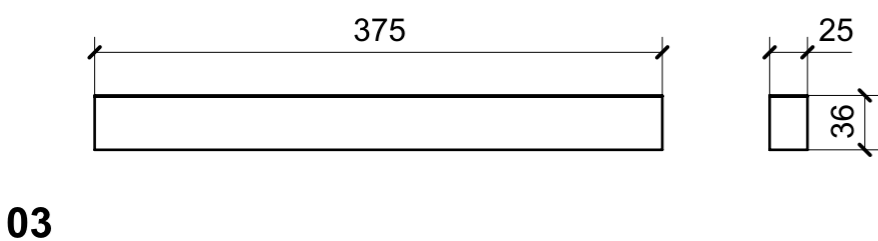
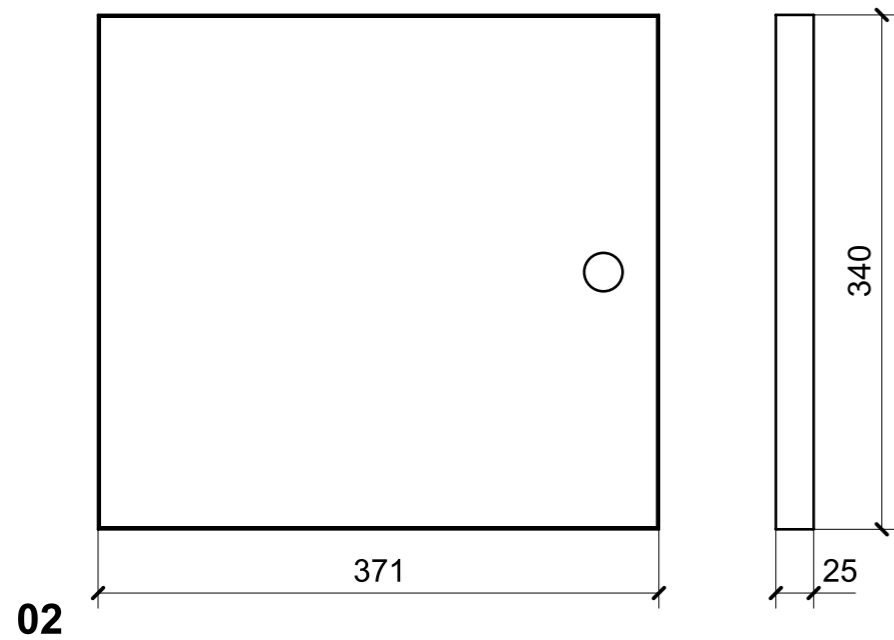
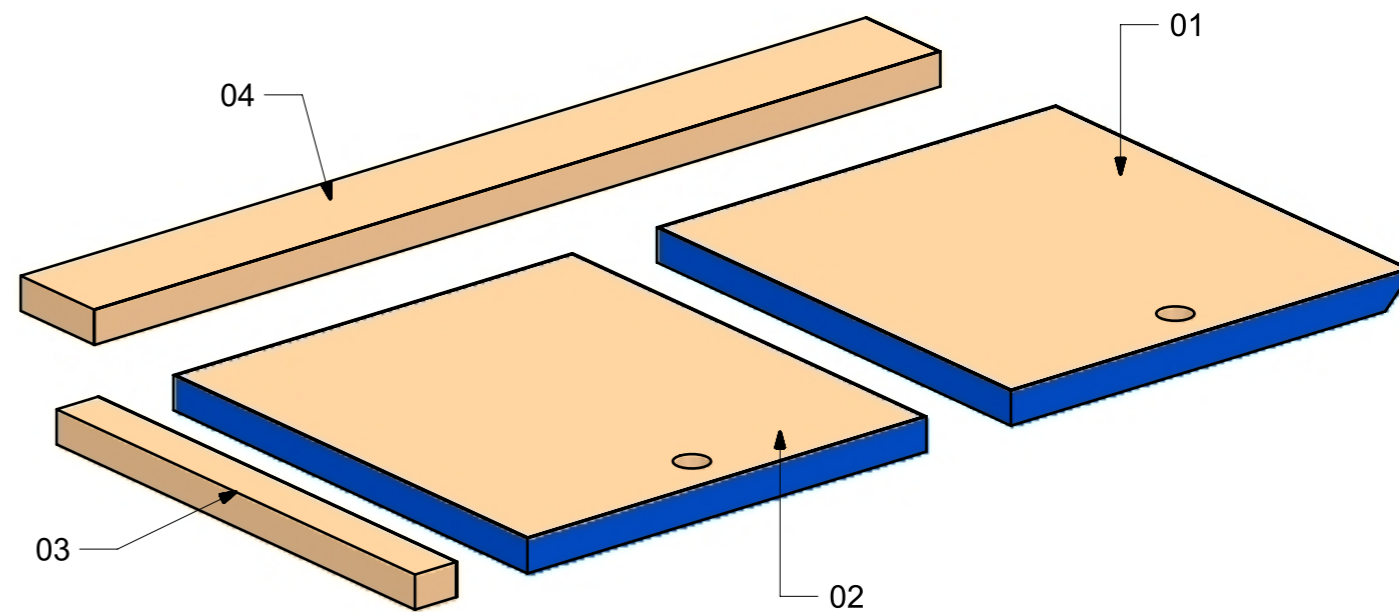
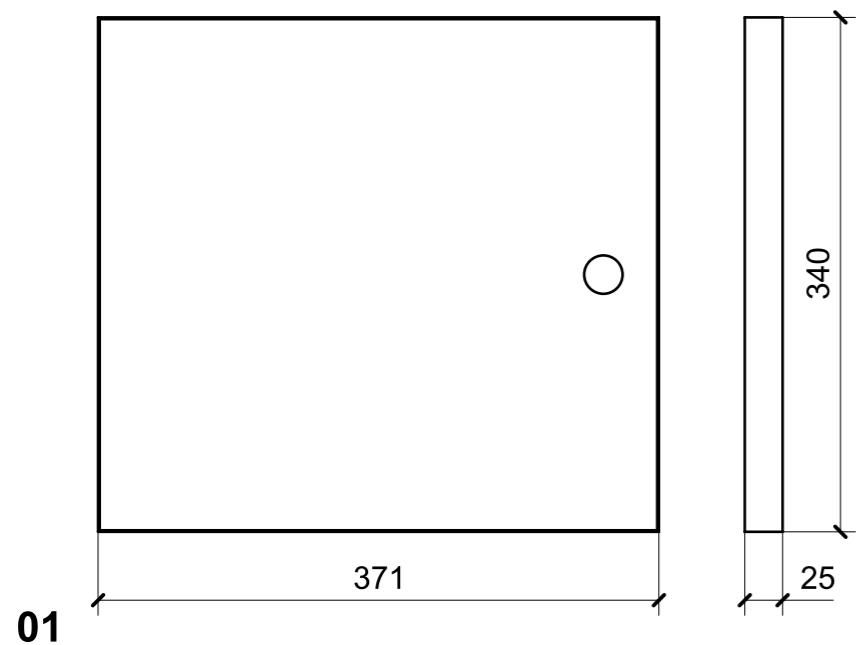

FERRAMENTA	QTY
PUSH TO CLOSE_SOUTHCO-MP-05-312-55 NERA_TECHNOPARTNER	2
BUSSOLA 5MA ANKOR BORGHIS X CERNIERA COLLO PIENO	16
BUSSOLA 6MA X 10 FORO DIAM.8	3

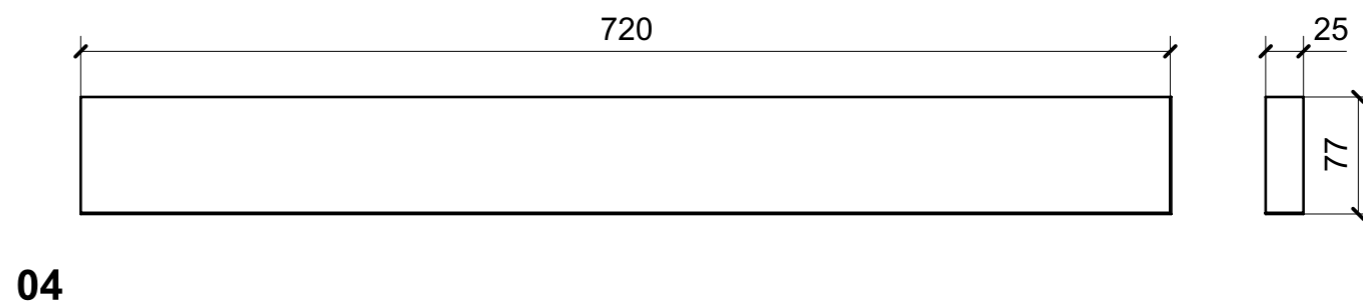

VERNICIATURA LASTRA/LACCATI:

● = VERNICIARE 1 LATO + FILI RASATI O BORDATI

NESSUN SIMBOLO = VERNICIARE 2 LATI + FILI RASATI O BORDATI

LOCALE	CODICE	DESCRIZIONE COMPONENTE	FINITURA	GR.
CABINA ARMATORE	MD321_R00_AK01	MOBILE A RIBALTA POPPA SX	LASTRA ALPI JAY STRIPED 12.35	2

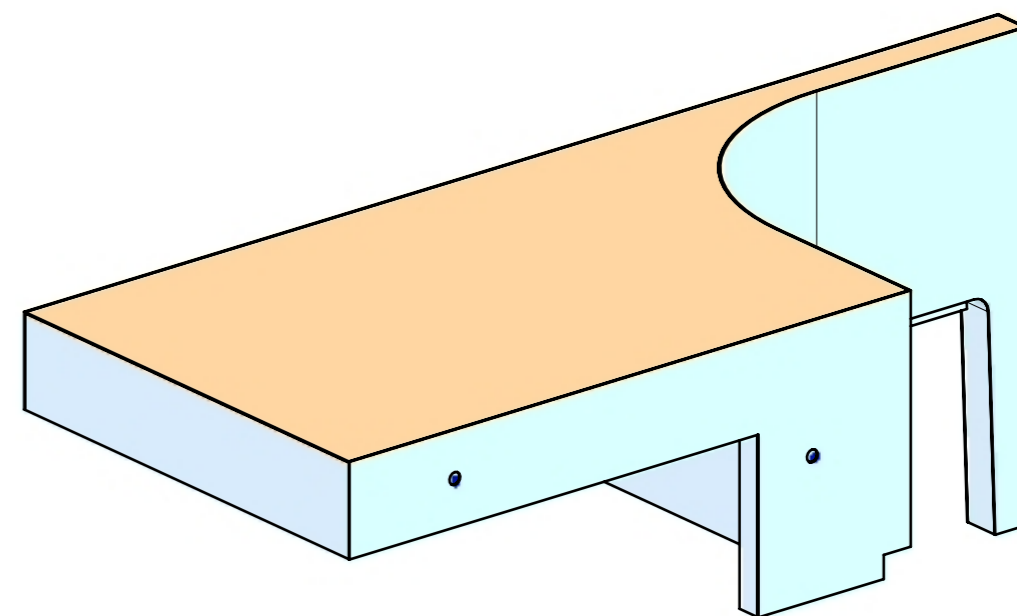
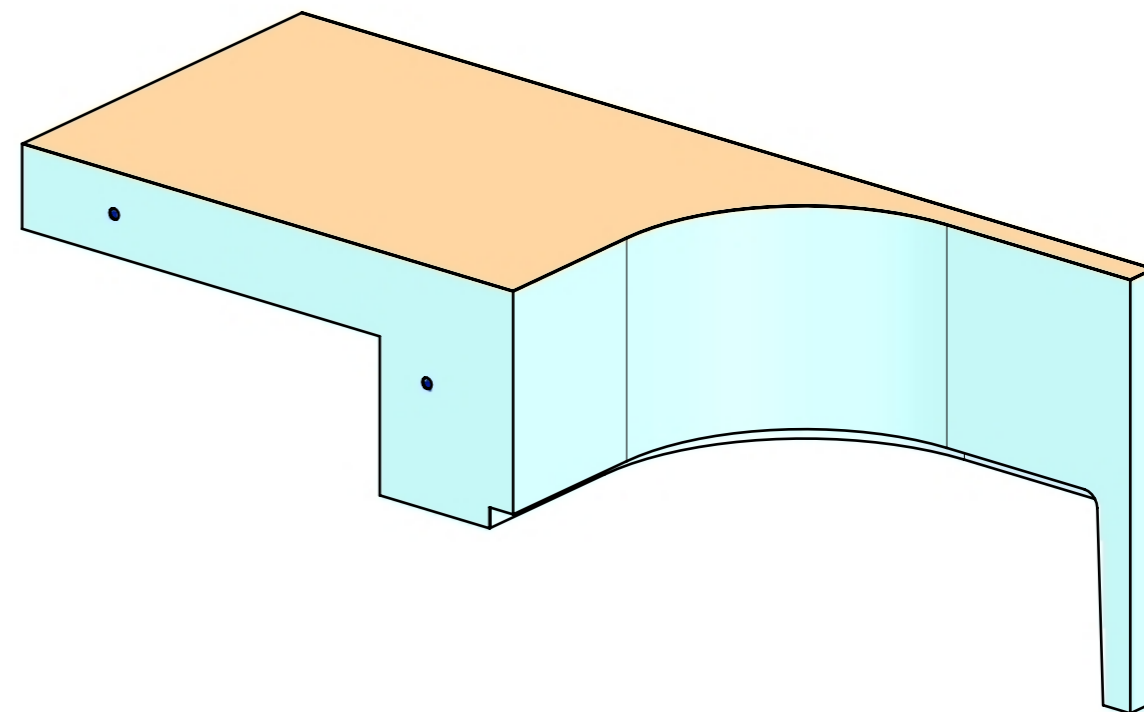
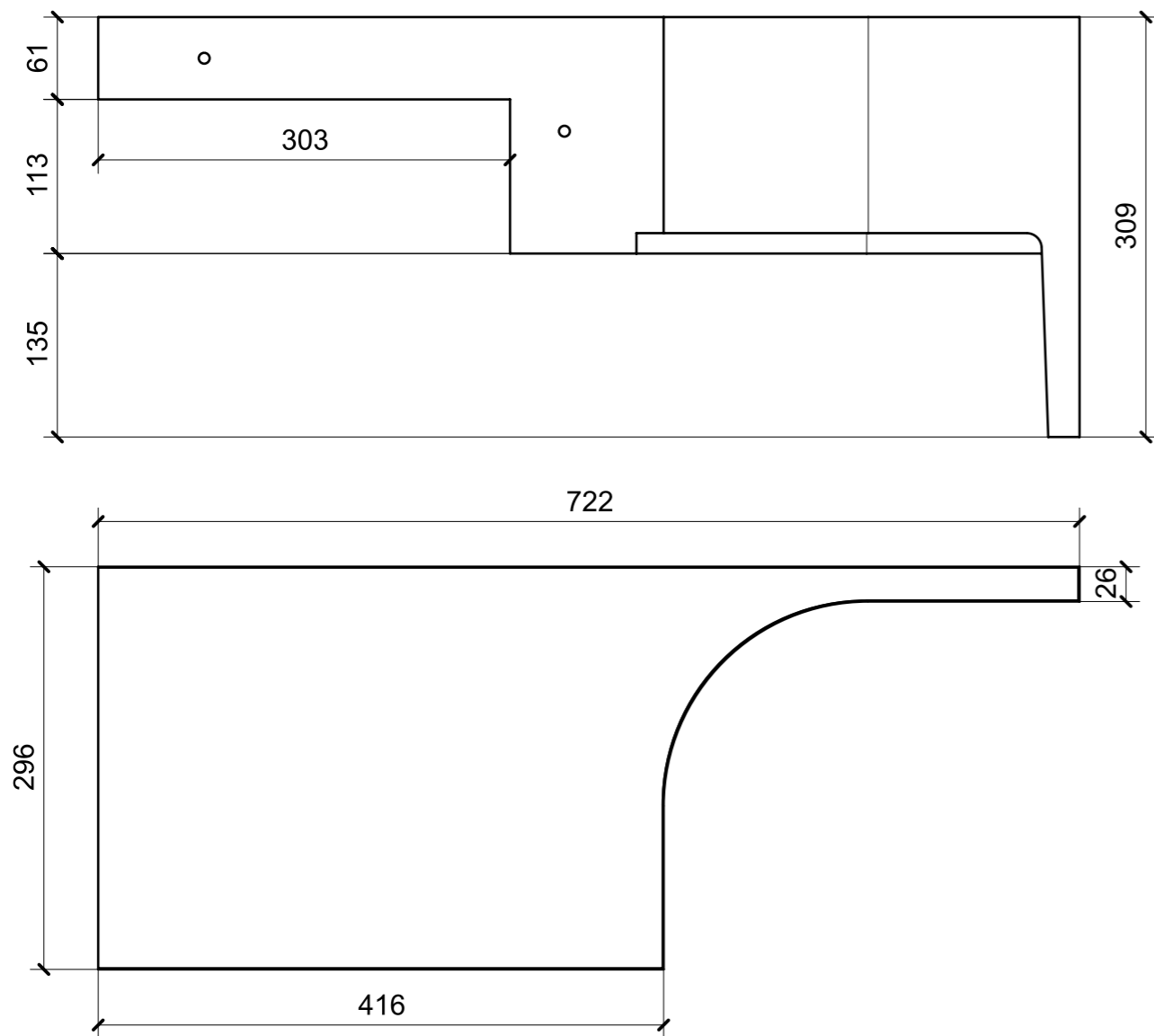

FERRAMENTA	QTY
BUSSOLA 6MA X 10 FORO DIAM.8	4

VERNICIATURA LASTRA/LACCATI:

● = FILI RASATI

● = VERNICIARE 1 LATO + FILI RASATI O BORDATI

NESSUN SIMBOLO = VERNICIARE 2 LATI + FILI RASATI O BORDATI

LOCALE	CODICE	DESCRIZIONE COMPONENTE	FINITURA	GR.
CABINA ARMATORE	MD321_R01_AM01	STRUTTURA TESTALETTO	LASTRA ALPI JAY STRIPED 12.35	2

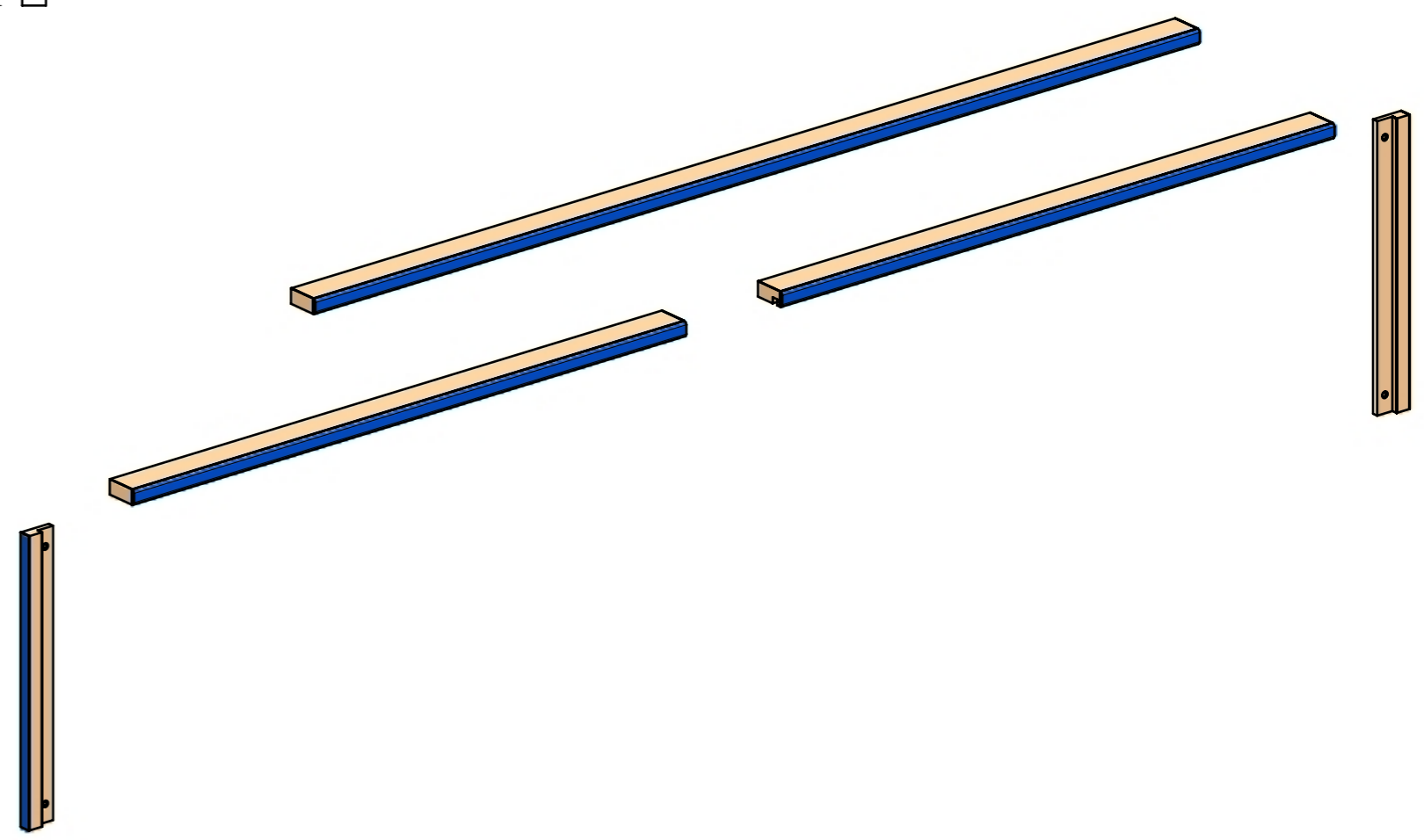
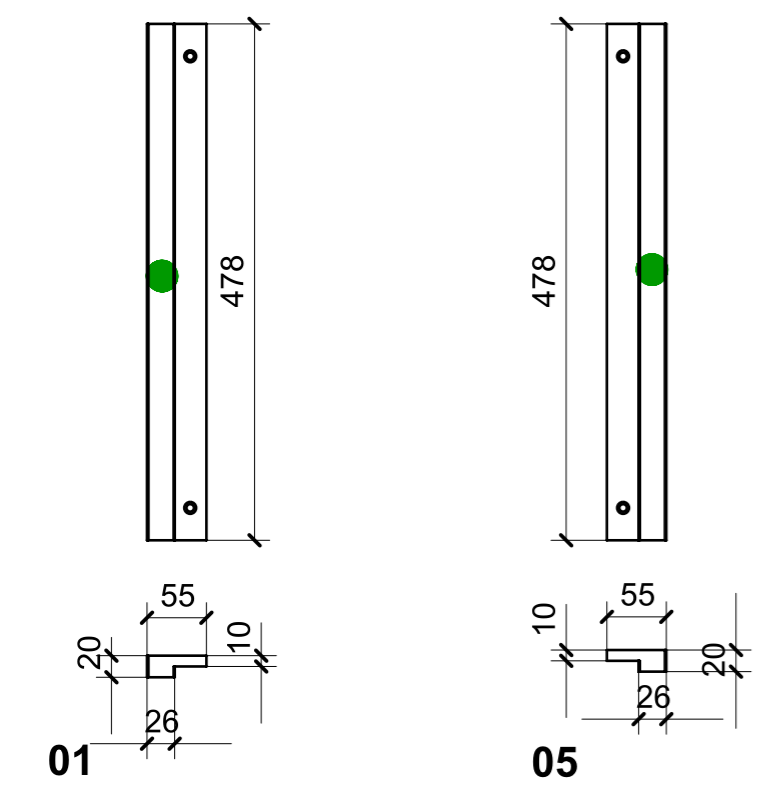
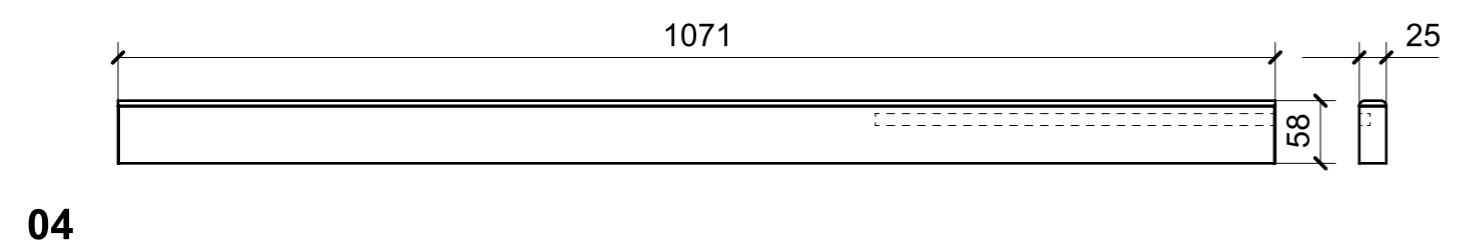
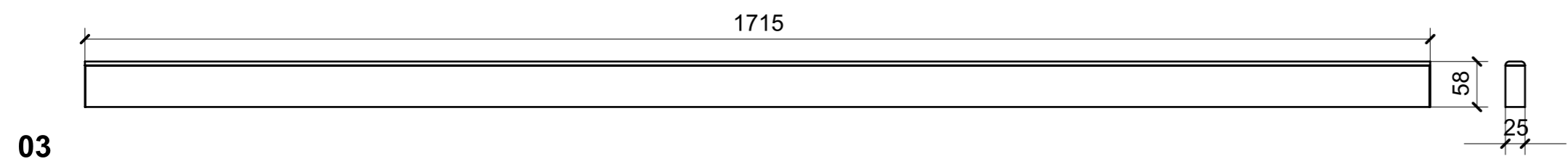
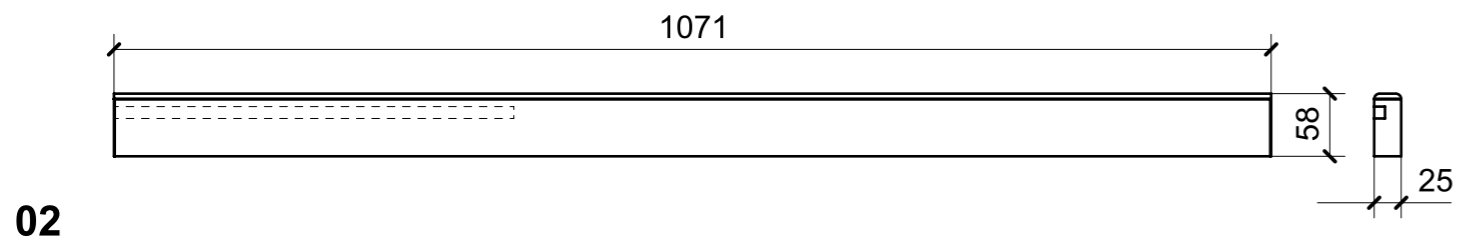

VERNICIATURA LASTRA/LACCATI:
 ● = VERNICIARE 1 LATO + FILI RASATI O BORDATI NESSUN SIMBOLO = VERNICIARE 2 LATI + FILI RASATI O BORDATI

LOCALE	CODICE	DESCRIZIONE COMPONENTE	FINITURA	GR.
CABINA ARMATORE	MD321_R01_AN01	STRUTTURA MURATA SX	LASTRA ALPI JAY STRIPED 12.35	PTP

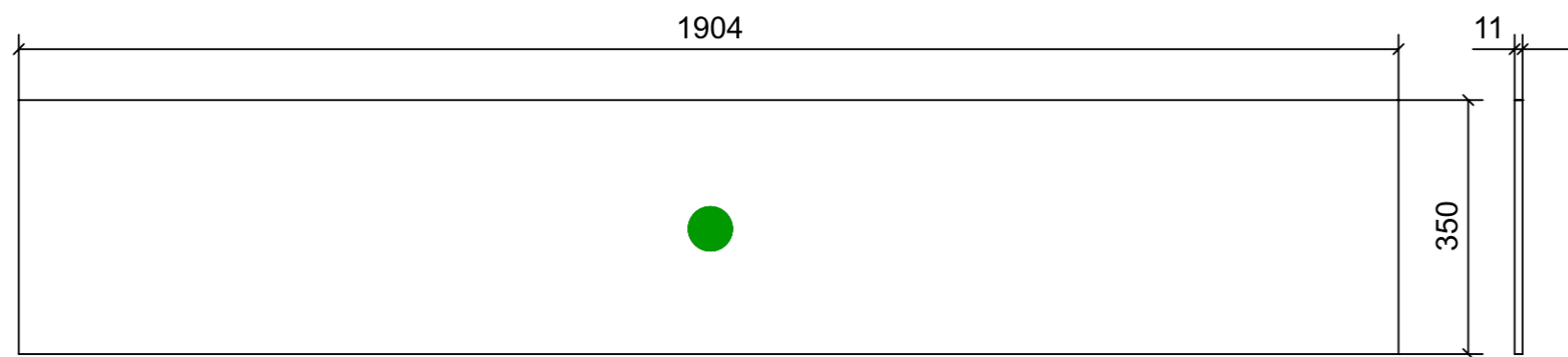
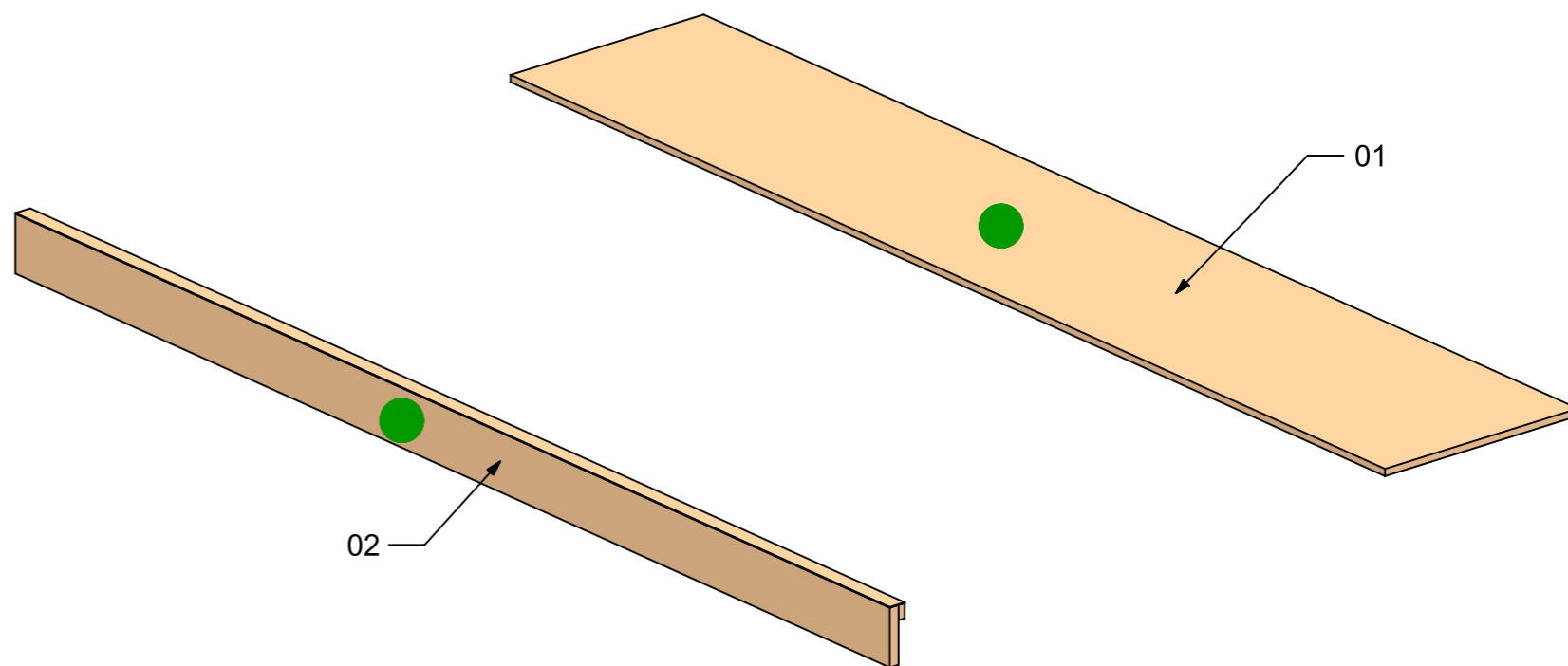

FERRAMENTA	QTY
MS INCASSO_ITALVIPLA_972_FMPC_M1B	5

01

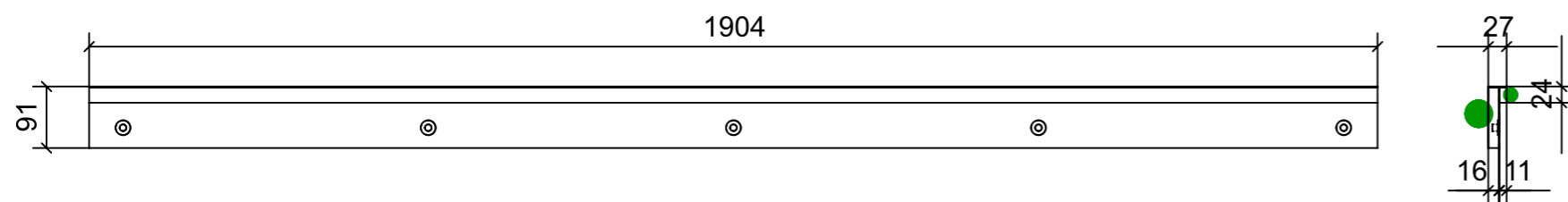

02

VERNICIATURA LASTRA/LACCATI:

● = VERNICIARE 1 LATO + FILI RASATI O BORDATI

NESSUN SIMBOLO = VERNICIARE 2 LATI + FILI RASATI O BORDATI

LOCALE	CODICE	DESCRIZIONE COMPONENTE	FINITURA	GR.
CABINA ARMATORE	MD321_R01_AO01	PLENUM	LASTRA ALPI JAY STRIPED 12.35	2

01

ELEMENTO DA MONTARE
in MF_AO01
e spedire con unico imballo

02

03

04

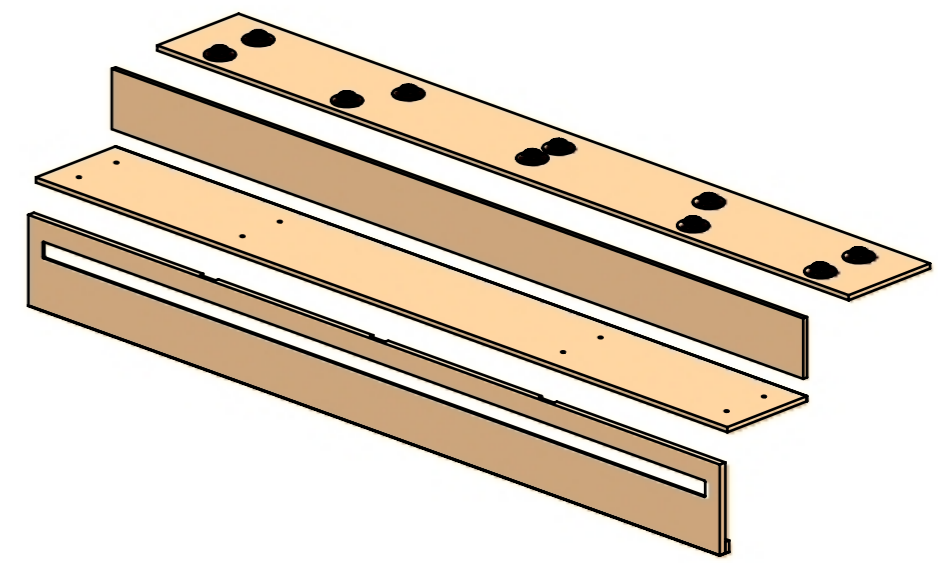

FERRAMENTA	QTY
FITLOCK M_MASCHERPA_3MM_6020202101	10

VERNICIATURA LASTRA/LACCATI:
 ● = VERNICIARE 1 LATO + FILI RASATI O BORDATI NESSUN SIMBOLO = VERNICIARE 2 LATI + FILI RASATI O BORDATI

LOCALE	CODICE	DESCRIZIONE COMPONENTE	FINITURA	GR.
CABINA ARMATORE	MD321_R01_AQ01	CASSETTIERA MURATA SX	VALCROMAT + LASTRA ALPI JAY STRIPPED 12.35	2

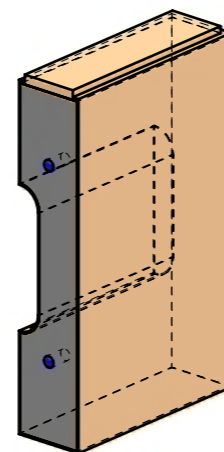
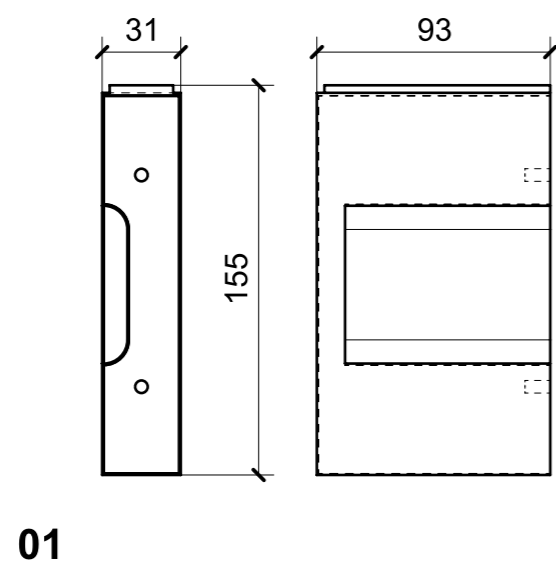

ELEMENTO DA MONTARE
con R02_01 in MF_AQ01
e spedire con unico imballo

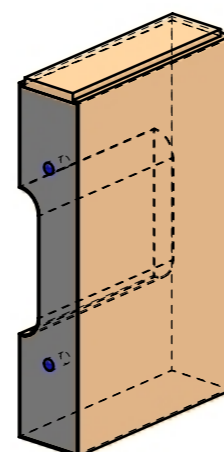
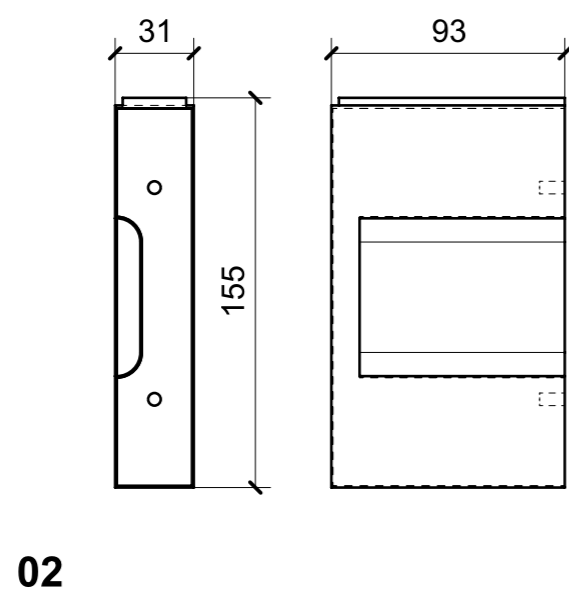
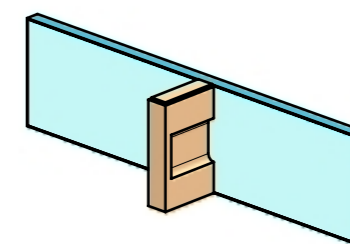

ELEMENTO DA MONTARE
con R02_02 in MF_AQ02
e spedire con unico imballo

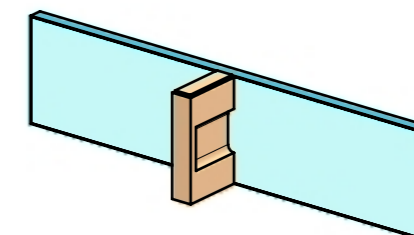

VERNICIATURA LASTRA/LACCATI:

● = VERNICIARE 1 LATO + FILI RASATI O BORDATI

NESSUN SIMBOLO = VERNICIARE 2 LATI + FILI RASATI O BORDATI

LOCALE	CODICE	DESCRIZIONE COMPONENTE	FINITURA	GR.
CABINA ARMATORE	MD321_R02_AQ01	CASSETTIERA MURATA SX	LASTRA ALPI JAY FLAMED 12.34	2

01

ELEMENTO DA MONTARE con R01_01 in MF_AQ01 e spedire con unico imballo

02

ELEMENTO DA MONTARE con R01_02 in MF_AQ02 e spedire con unico imballo

03 VALCROMAT + LASTRA ALPI JAY FLAMED 12.34

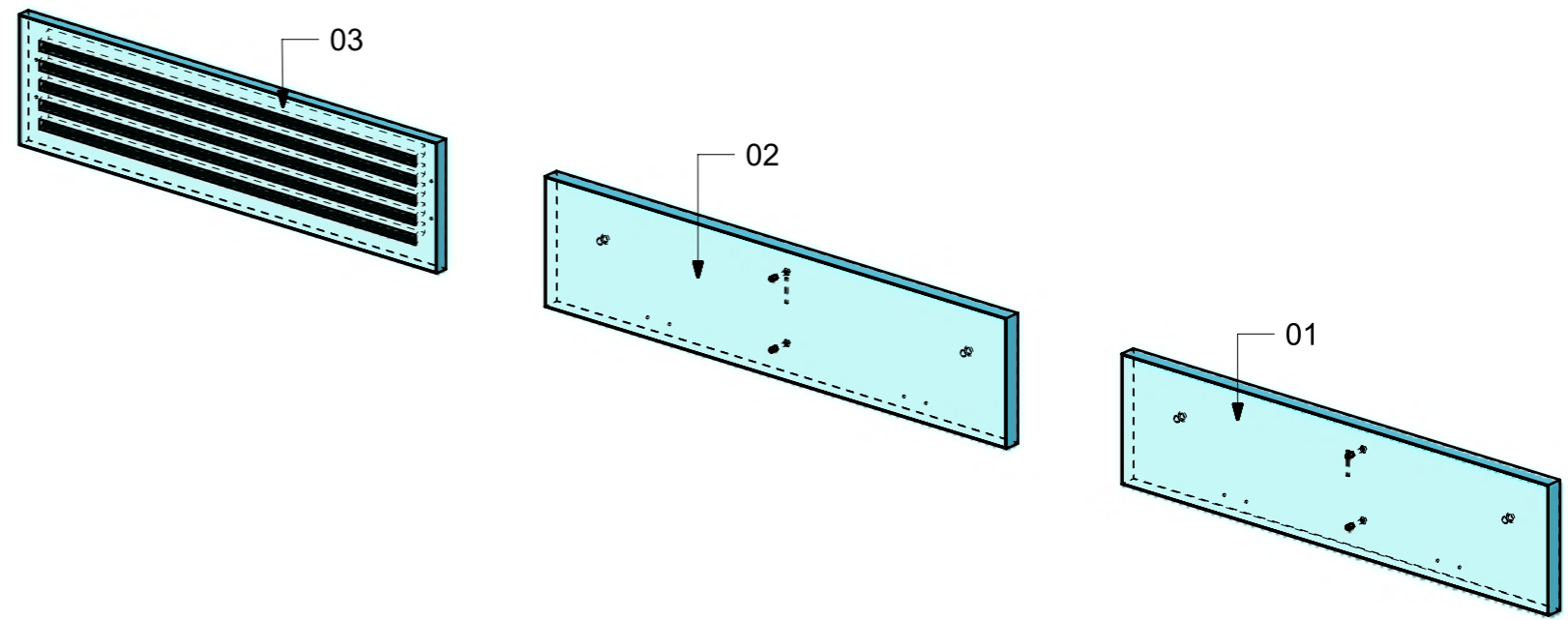

VERNICIATURA LASTRA/LACCATI:

● = VERNICIARE 1 LATO + FILI RASATI O BORDATI

NESSUN SIMBOLO = VERNICIARE 2 LATI + FILI RASATI O BORDATI

LOCALE	CODICE	DESCRIZIONE COMPONENTE	FINITURA	GR.
CABINA ARMATORE	MD321_R01_AAQ01	ANTE CASSETTIERA MURATA_STD VAR.1 VERDE LUCIDO RAL 6013	MDF LASTRATO ALPI JAY STRIPED 12.35	2

01

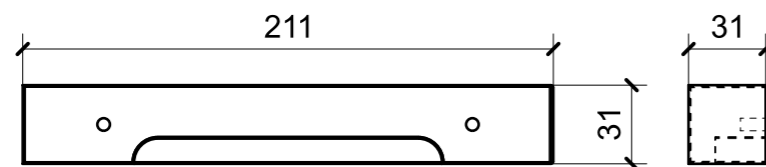

02

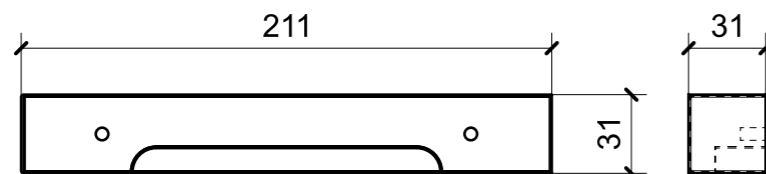

03

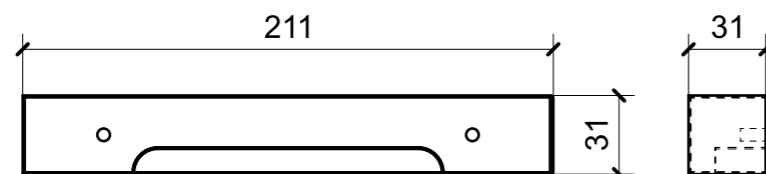

04

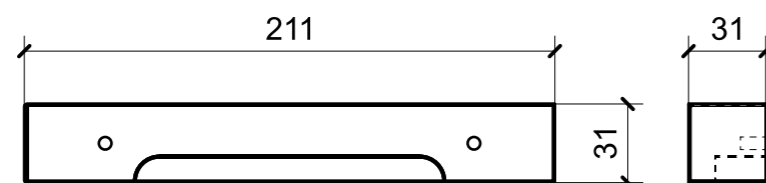

ELEMENTI DA MONTARE
con laccati L03_01-->04
in MF come indicato
e spedire con unico imballo

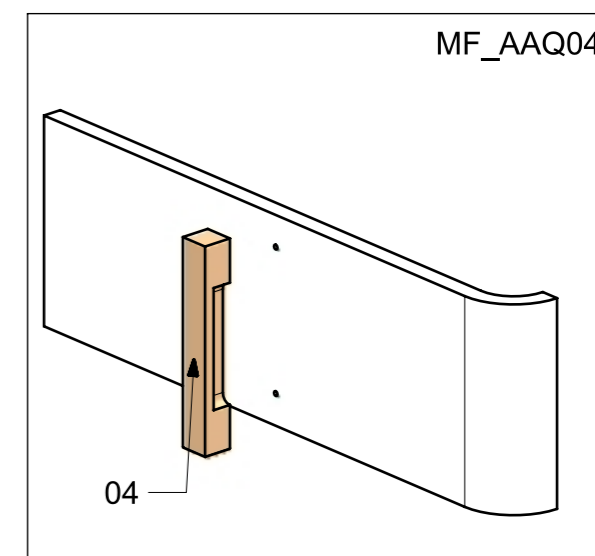
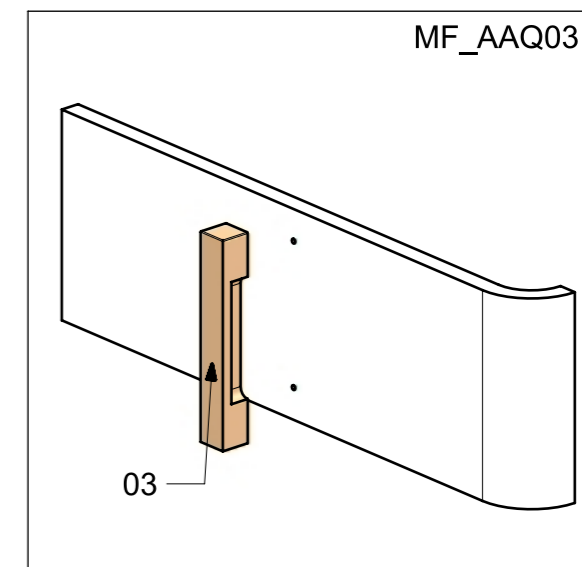
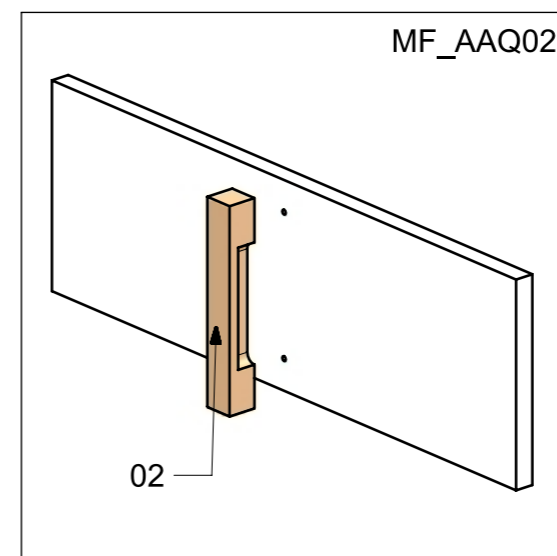
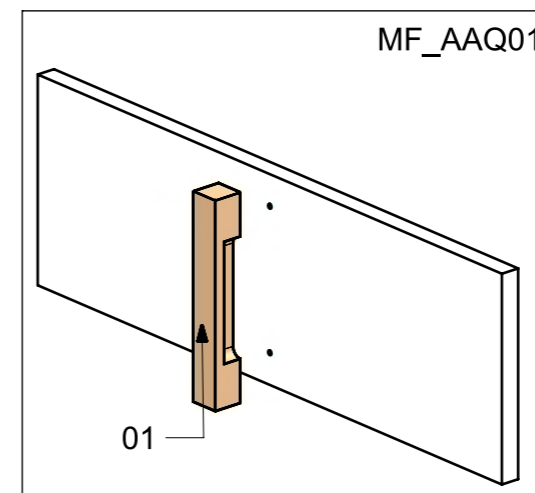

VERNICIATURA LASTRA/LACCATI:

● = VERNICIARE 1 LATO + FILI RASATI O BORDATI

NESSUN SIMBOLO = VERNICIARE 2 LATI + FILI RASATI O BORDATI

LOCALE	CODICE	DESCRIZIONE COMPONENTE	FINITURA	GR.
CABINA ARMATORE	MD321_R01_AQQ01	ANTE CASSETTIERA MURATA_STD VAR.2 PANNA LUCIDO NCS S 1505-Y30R	MDF LASTRATO ALPI JAY STRIPED 12.35	2

ELEMENTI DA MONTARE
con laccati L03_01-->04
in MF come indicato
e spedire con unico imballo

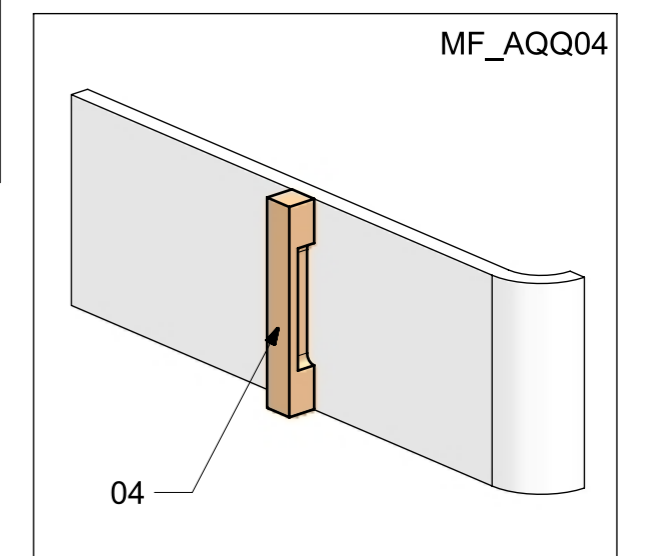
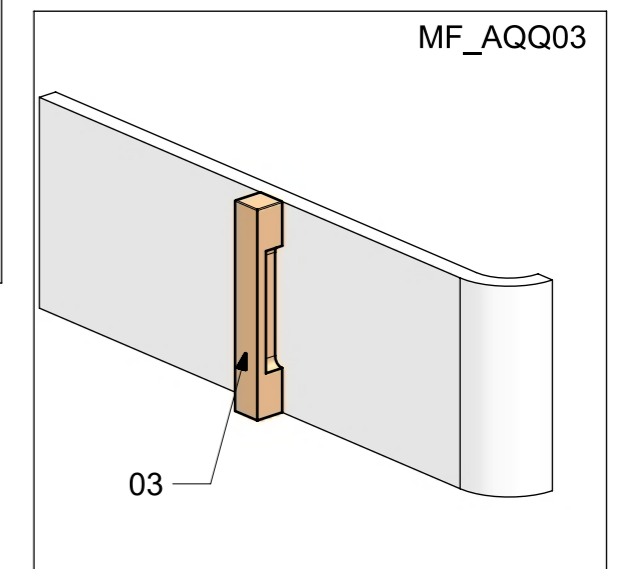
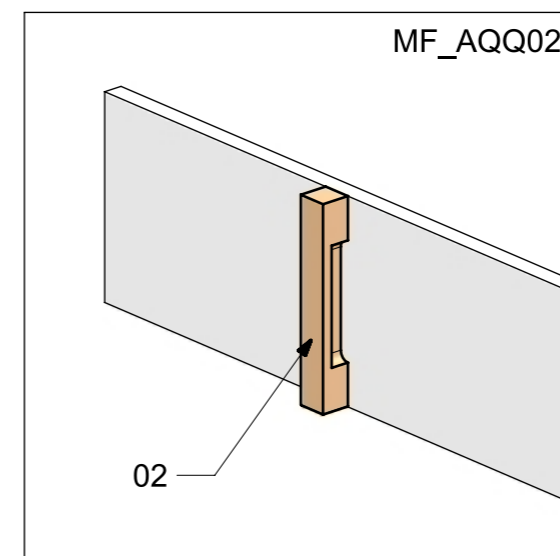
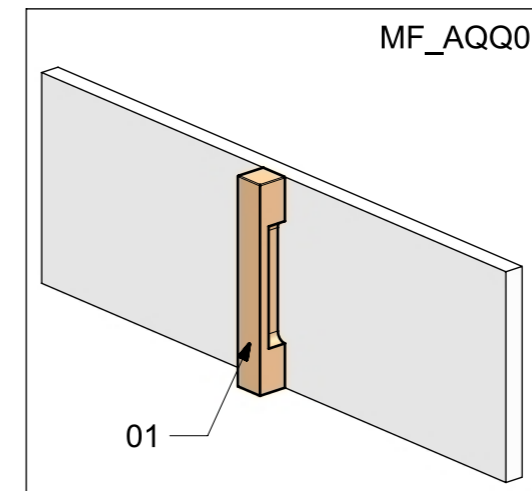
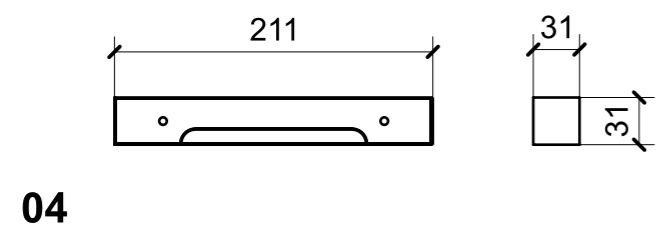
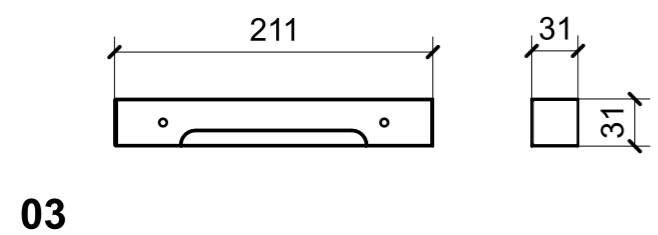
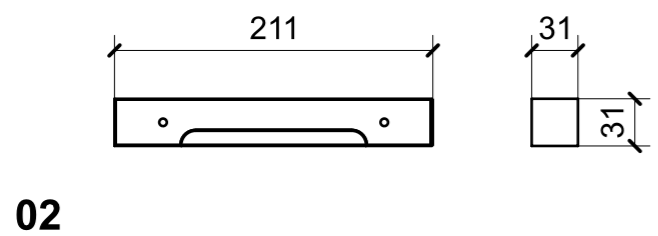
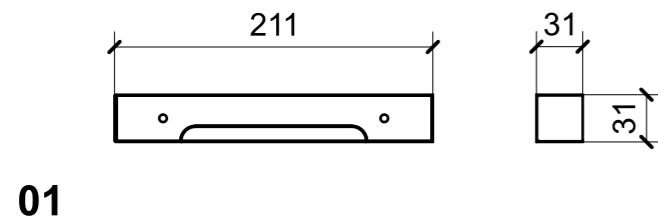

VERNICIATURA LASTRA/LACCATI:

● = VERNICIARE 1 LATO + FILI RASATI O BORDATI

NESSUN SIMBOLO = VERNICIARE 2 LATI + FILI RASATI O BORDATI

LOCALE	CODICE	DESCRIZIONE COMPONENTE	FINITURA	GR.
CABINA ARMATORE	MD321_R01_AR01	TOP CASSETTIERA MURATA SX OPT	LAISTRA ALPI JAY STRIPED 12.35	PTP

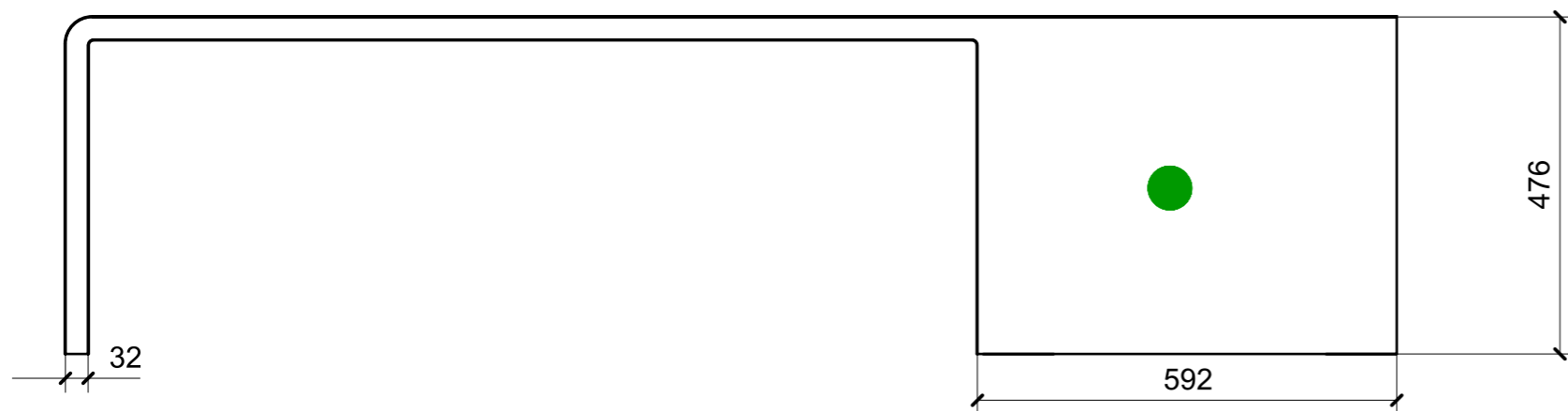
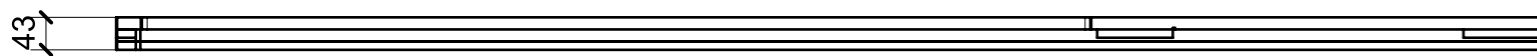

VISTA DA SOPRA



01 VISTA DA SOTTO

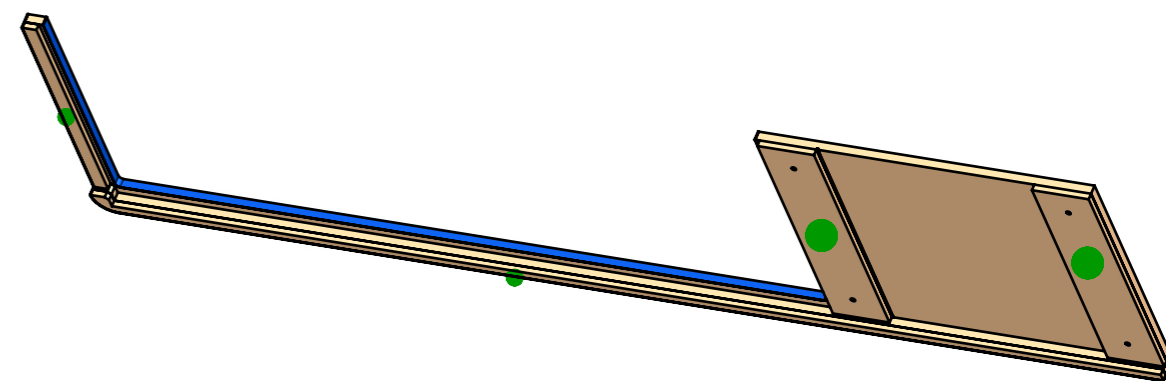
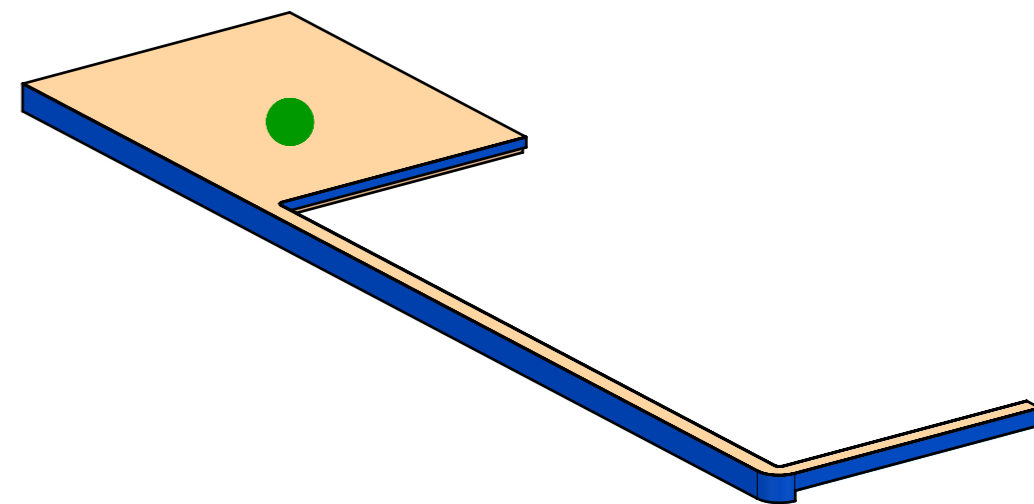

FERRAMENTA	QTY
BUSSOLA 6MA X 10 FORO DIAM.8	4

VERNICIATURA LASTRA/LACCATI:

● = VERNICIARE 1 LATO + FILI RASATI O BORDATI

NESSUN SIMBOLO = VERNICIARE 2 LATI + FILI RASATI O BORDATI

LOCALE	CODICE	DESCRIZIONE COMPONENTE	FINITURA	GR.
CABINA ARMATORE	MD321_R01_AZ01	MONTANTE VERTICALE RIV. TV	LASTRA ALPI JAY STRIPED 12.35	PTP

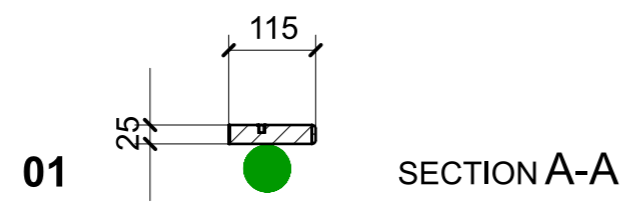
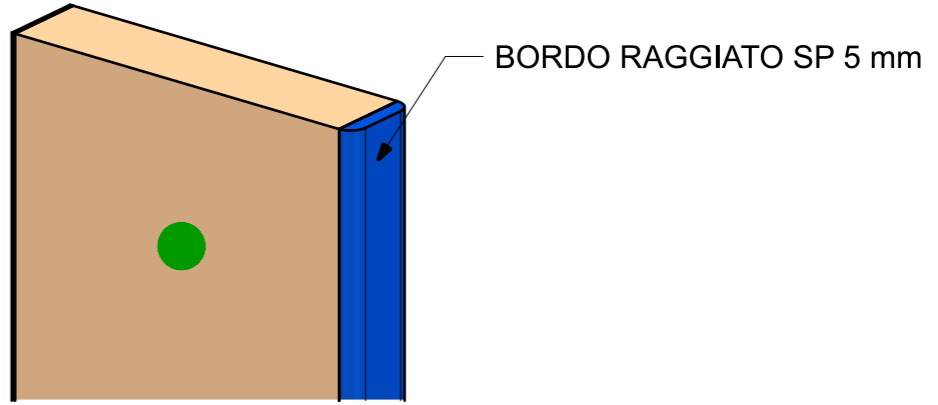
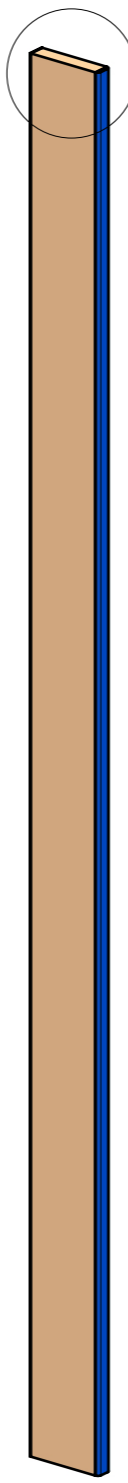
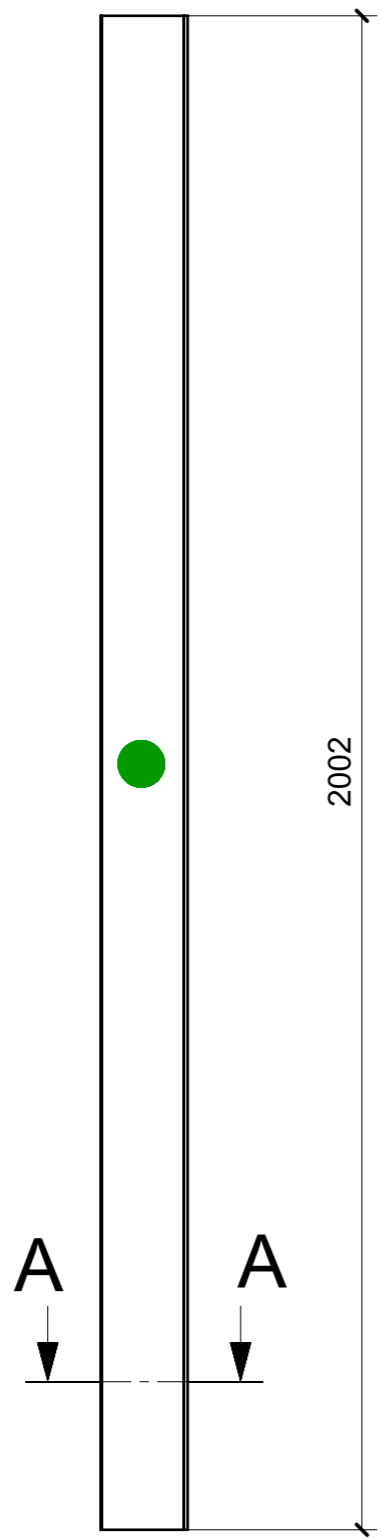

FERRAMENTA	QTY
BUSSOLA 6MA X 10 FORO DIAM.8	3

VERNICIATURA LASTRA/LACCATI:
 ● = VERNICIARE 1 LATO + FILI RASATI O BORDATI NESSUN SIMBOLO = VERNICIARE 2 LATI + FILI RASATI O BORDATI

LOCALE	CODICE	DESCRIZIONE COMPONENTE	FINITURA	GR.
CABINA ARMATORE	MD321_R01_ADD01	CIELINO INGRESSO STD VAR.1 43"	LAISTRA ALPI JAY STRIPED 12.35	2

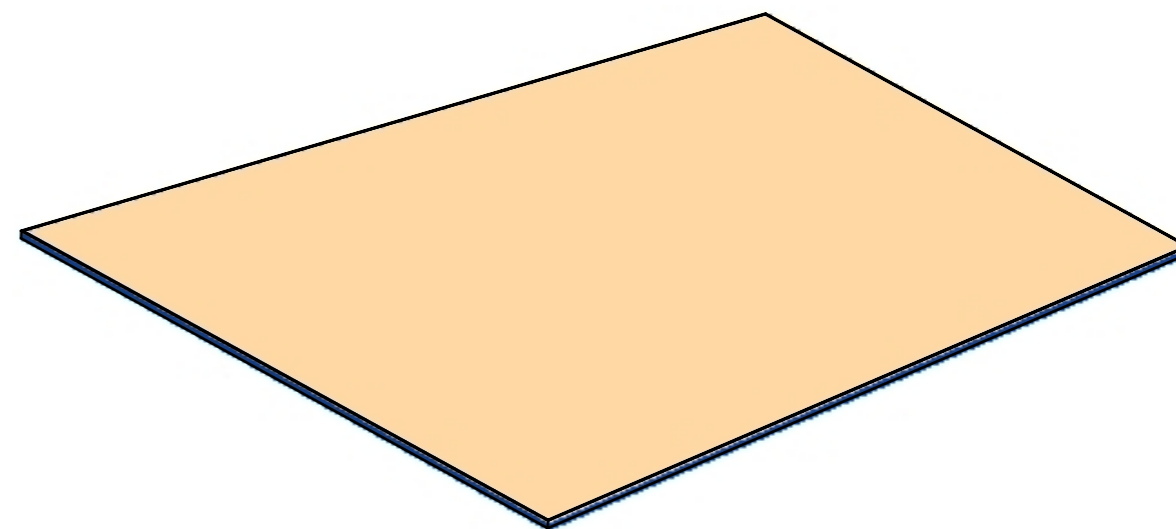
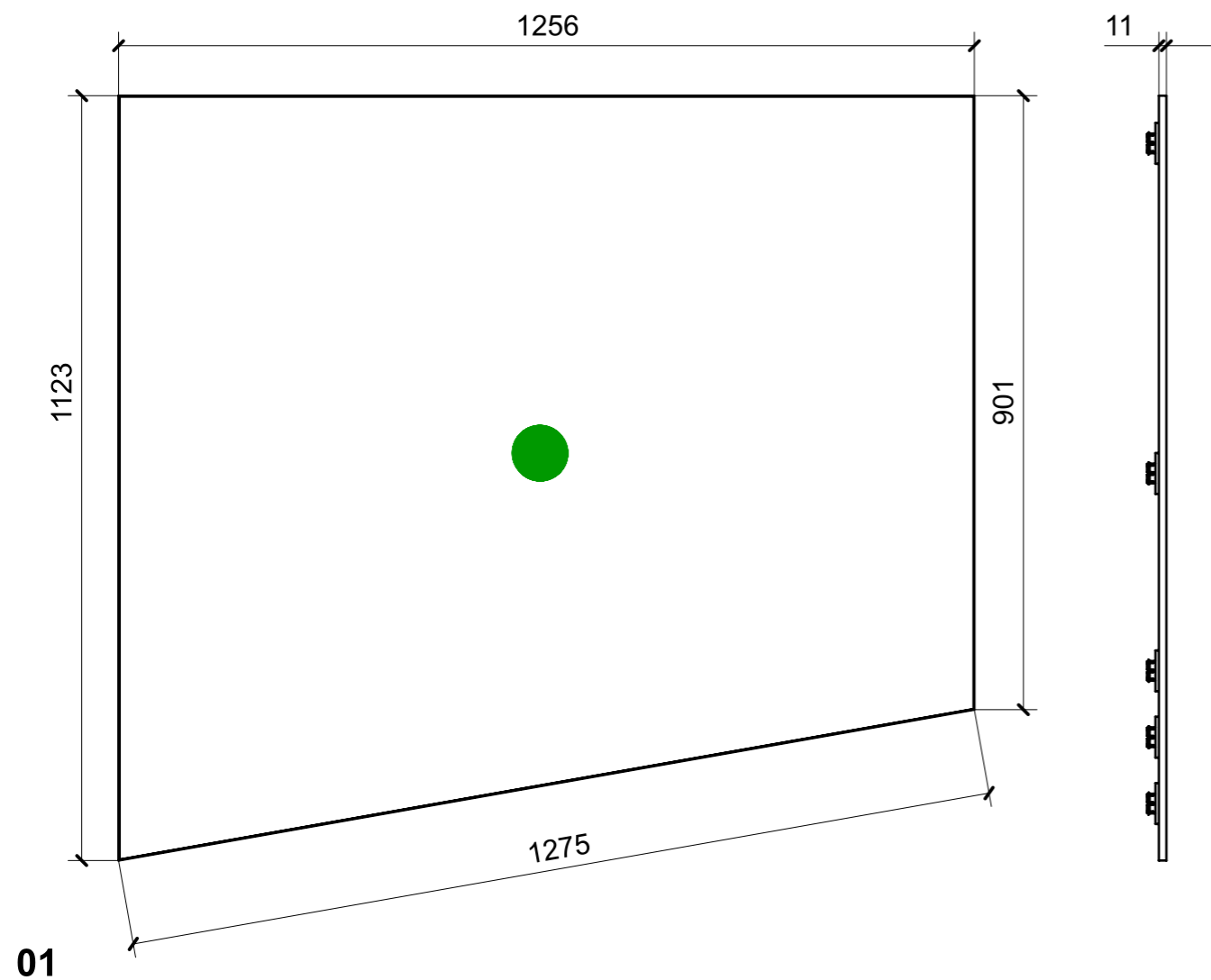

FERRAMENTA	QTY
FITLOCK M_MASCHERPA_5MM_6023030152	7

VERNICIATURA LASTRA/LACCATI:

● = VERNICIARE 1 LATO + FILI RASATI O BORDATI

NESSUN SIMBOLO = VERNICIARE 2 LATI + FILI RASATI O BORDATI

LOCALE	CODICE	DESCRIZIONE COMPONENTE	FINITURA	GR.
CABINA ARMATORE	MD321_R01_AAF01	MOBILE VANITY MURATA DX STD VAR.2	LASTRA ALPI JAY STRIPED 12.35	2

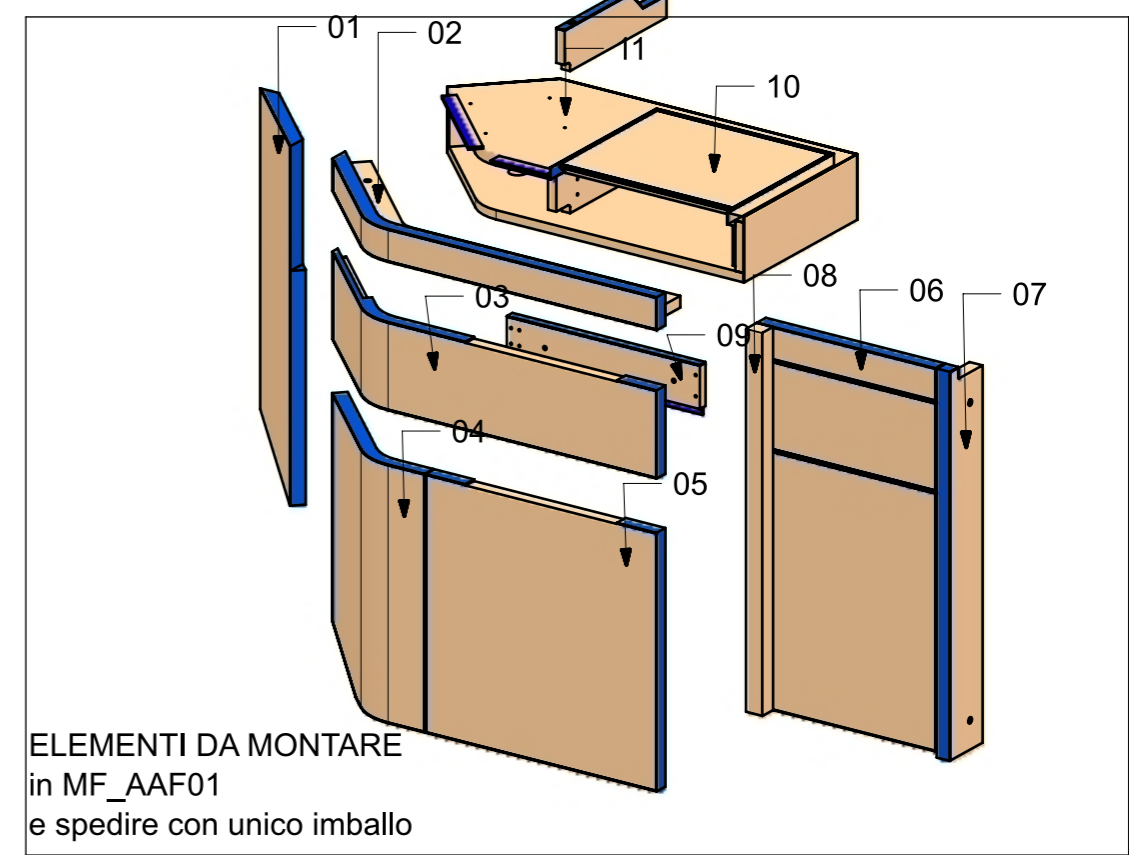
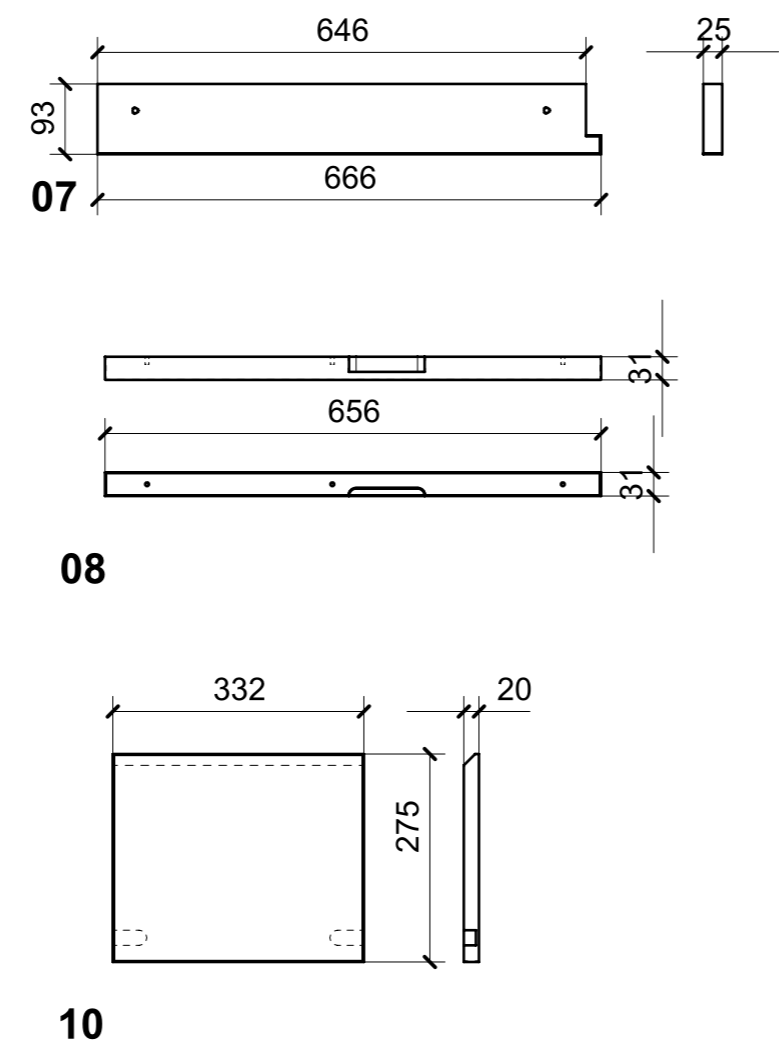
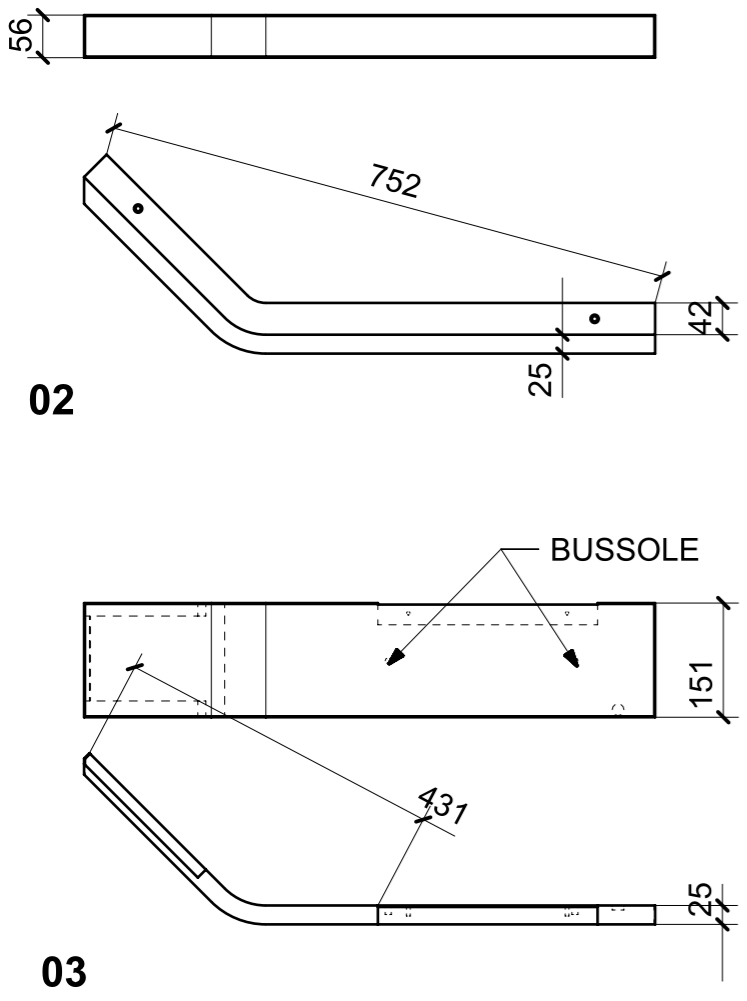
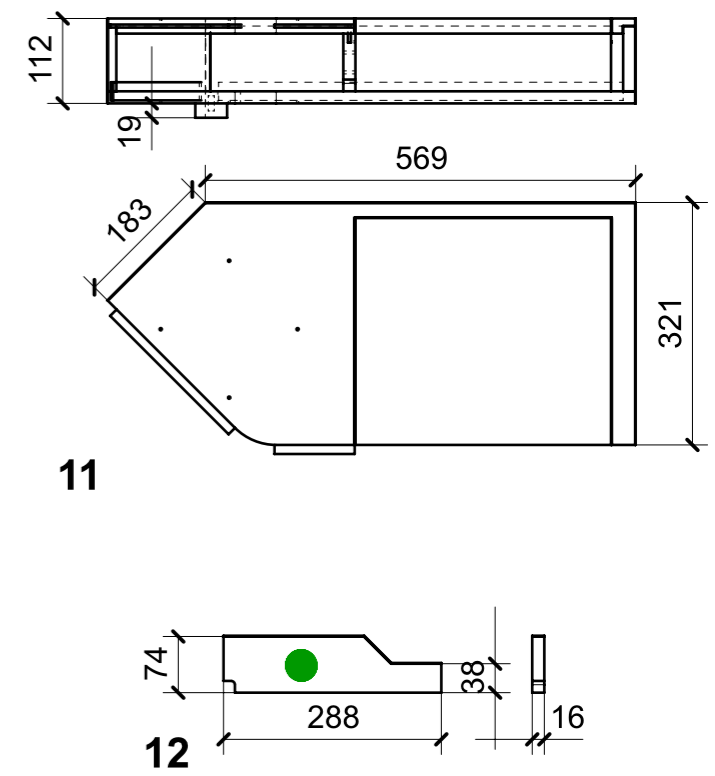
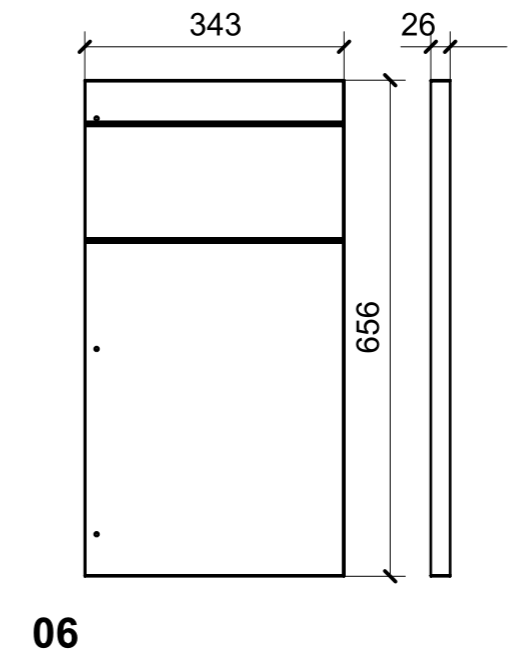
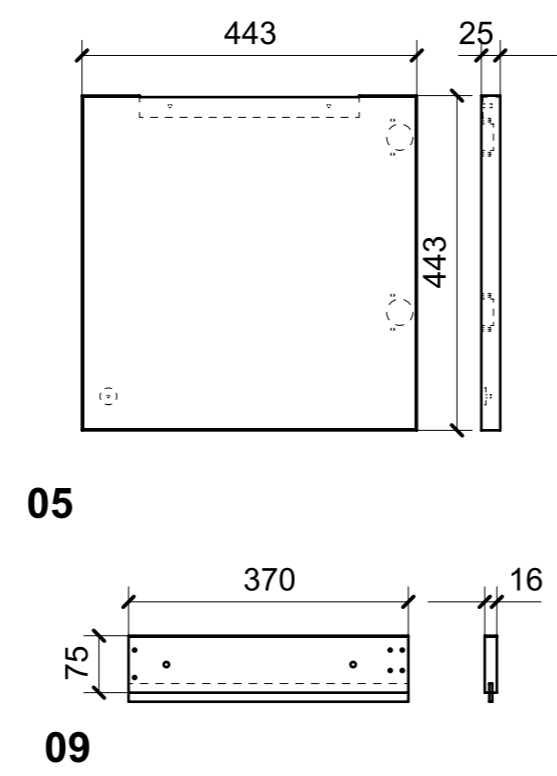
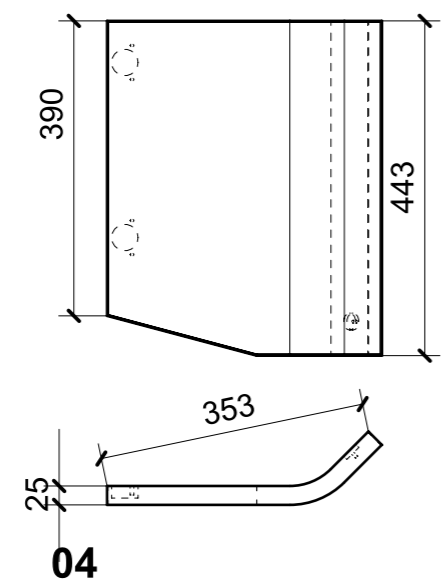
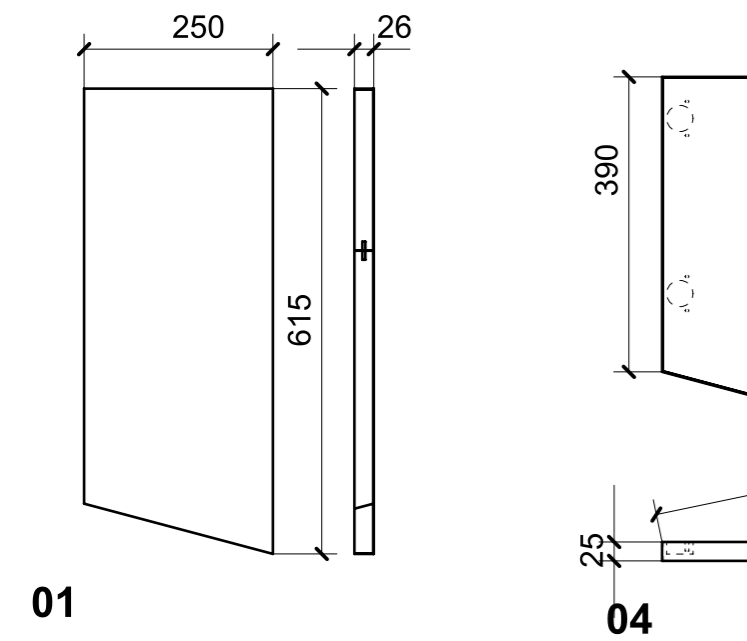

VERNICIATURA LASTRA/LACCATI:
● = VERNICIARE 1 LATO + FILI RASATI O BORDATI NESSUN SIMBOLO = VERNICIARE 2 LATI + FILI RASATI O BORDATI

LOCALE	CODICE	DESCRIZIONE COMPONENTE	FINITURA	GR.
CABINA ARMATORE	MD321_R01_AAG01	VASSOINETTO TRA DIVANI MURATA DX STD VAR.1	LAISTRA ALPI JAY STRIPED 12.35	PTP

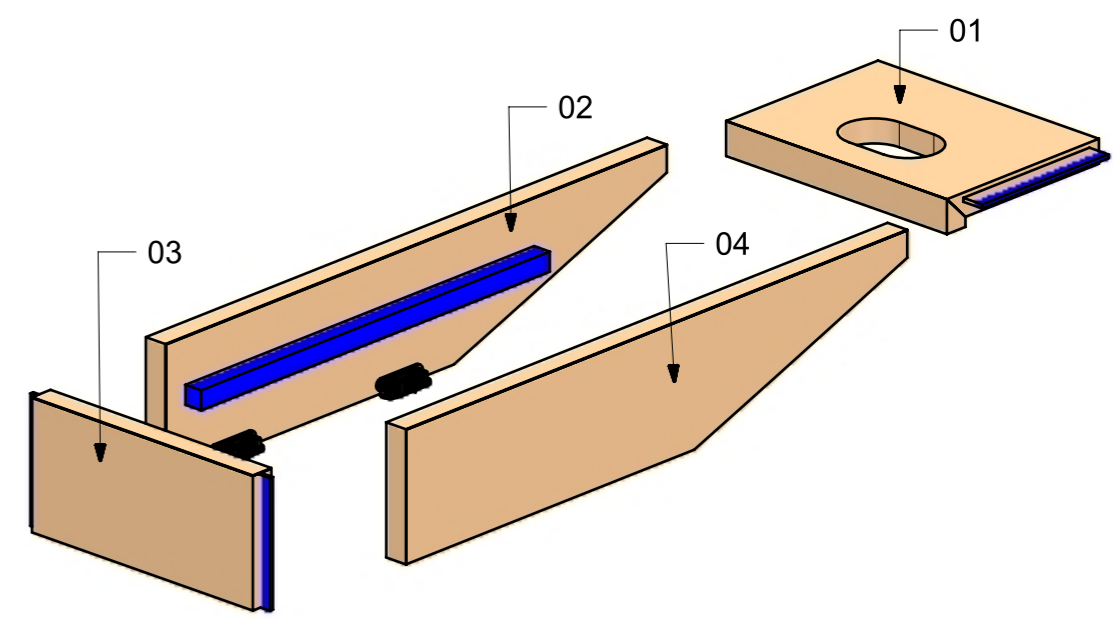
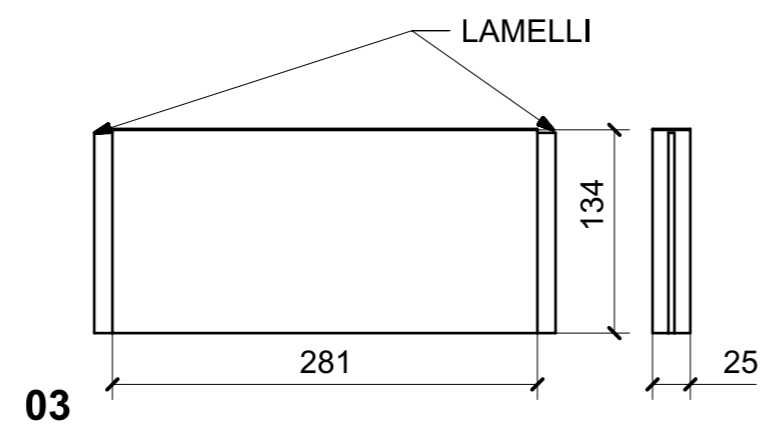
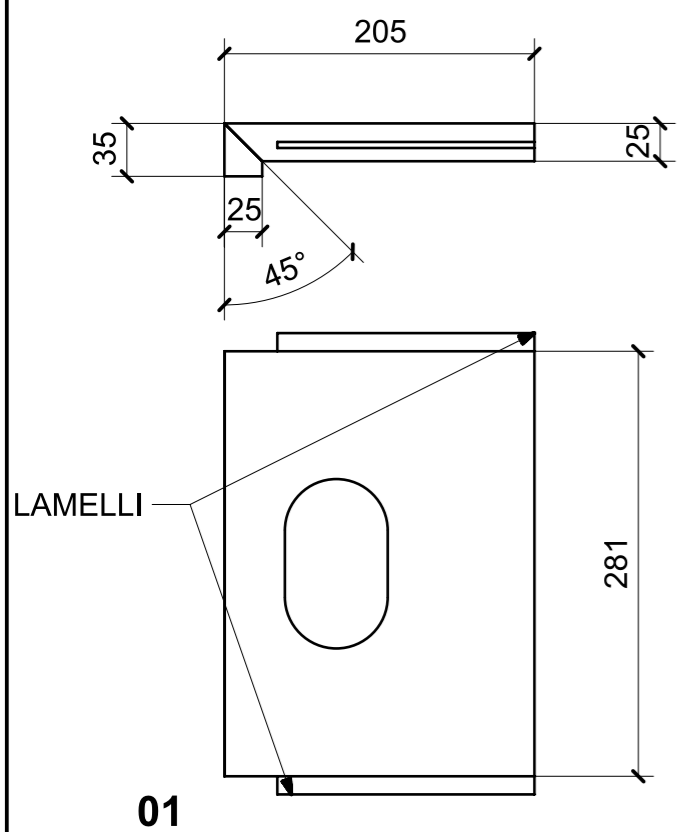
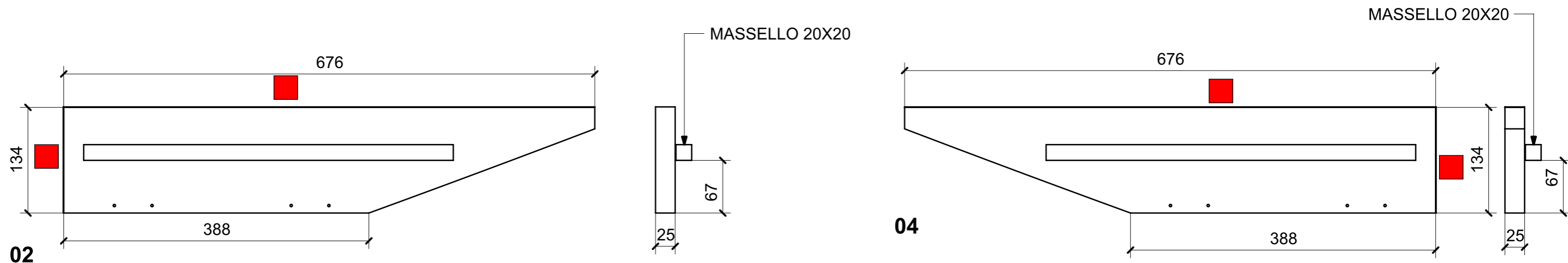

FERRAMENTA	QTY
FITLOCK KU	4

VERNICIATURA LASTRA/LACCATI:
 ● = VERNICIARE 1 LATO + FILI RASATI O BORDATI NESSUN SIMBOLO = VERNICIARE 2 LATI + FILI RASATI O BORDATI