

LOCALE	CODICE	DESCRIZIONE COMPONENTE	FINITURA	GR.
CUCINA	MD321_R01_KA01	BASE CUCINA MURATA	LAISTRA ALPI JAY STRIPED 12.35	2

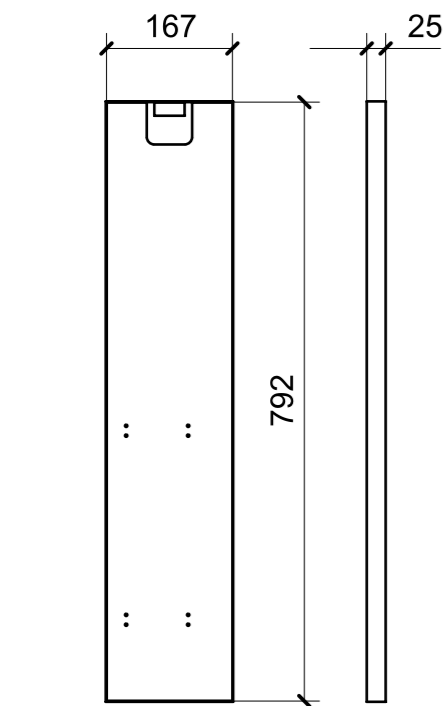

01

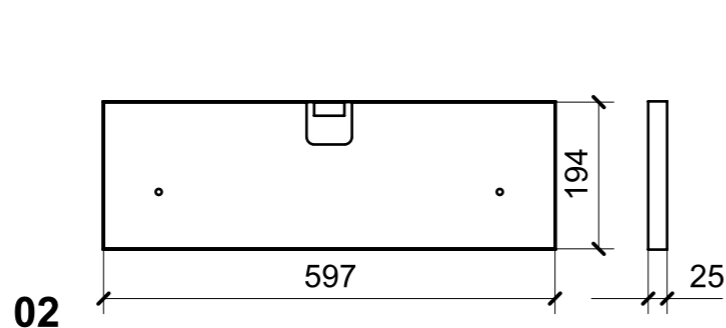

02

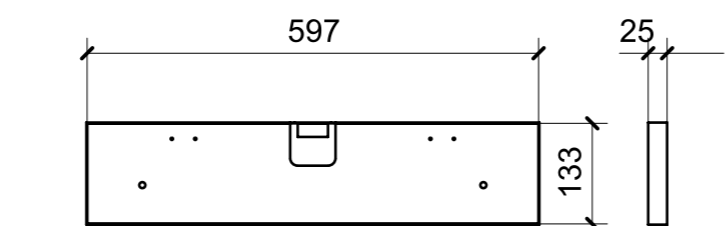

03

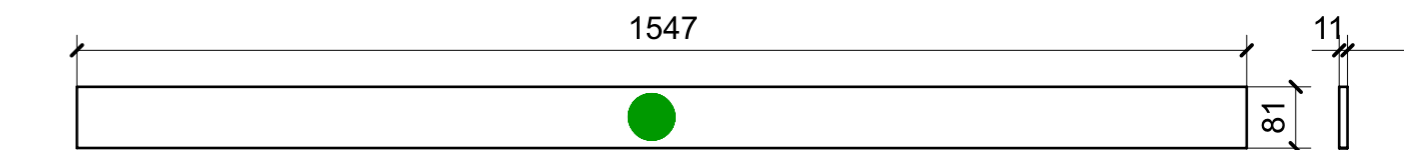

05

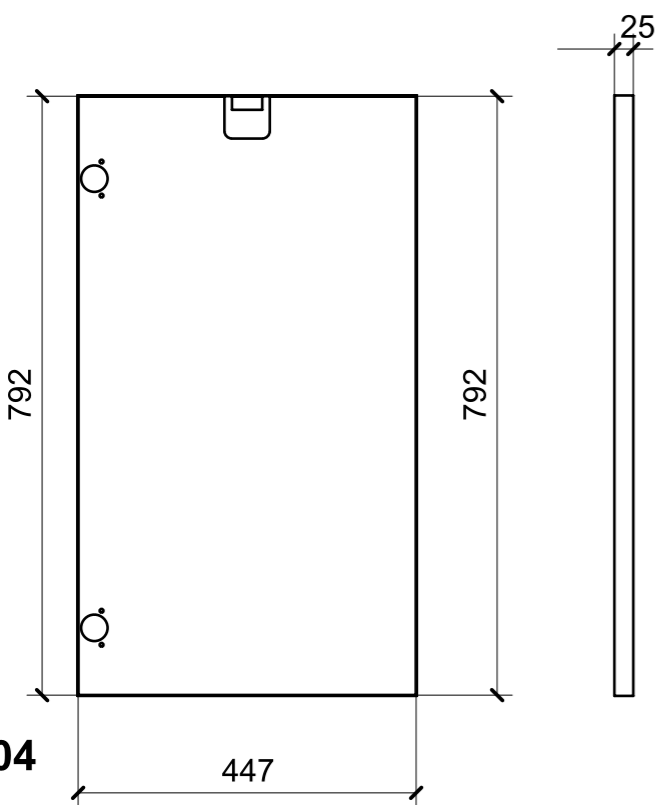

04

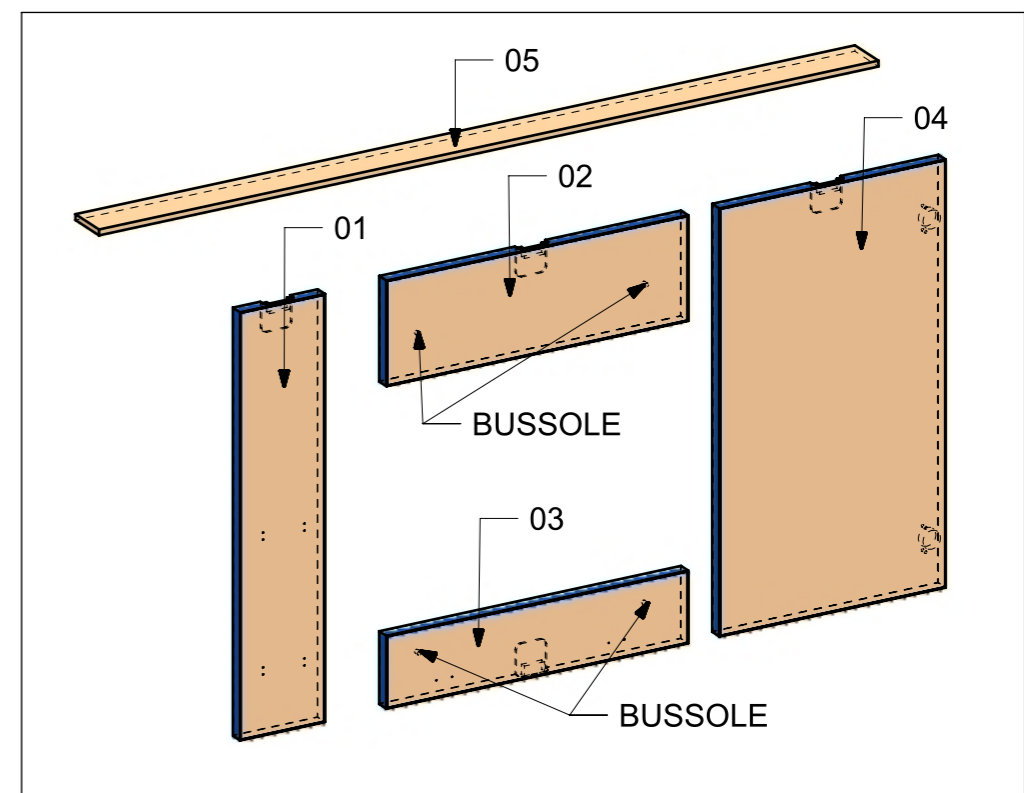

FERRAMENTA	QTY
BUSSOLA 5MA ANKOR BORGHI	4
BUSSOLA 6MA X 10 FORO DIAM.8	4
MANIGLIA AD INCASSO_FORESTI_ART 238 FINITURA BRUNITON	4
PLACCHETTA COUNTER STEEL_TECHNOPARTNER_MC-JM49	2

VERNICIATURA LASTRA/LACCATI:

● = VERNICIARE 1 LATO + FILI RASATI O BORDATI

NESSUN SIMBOLO = VERNICIARE 2 LATI + FILI RASATI O BORDATI

LOCALE	CODICE	DESCRIZIONE COMPONENTE	FINITURA	GR.
CUCINA	MD321_R01_KB01	BASE CUCINA PRUA	LASTRA ALPI JAY STRIPED 12.35	2

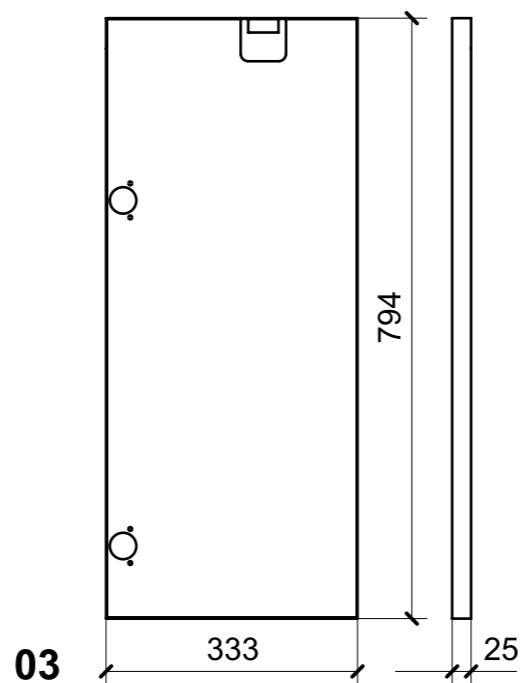
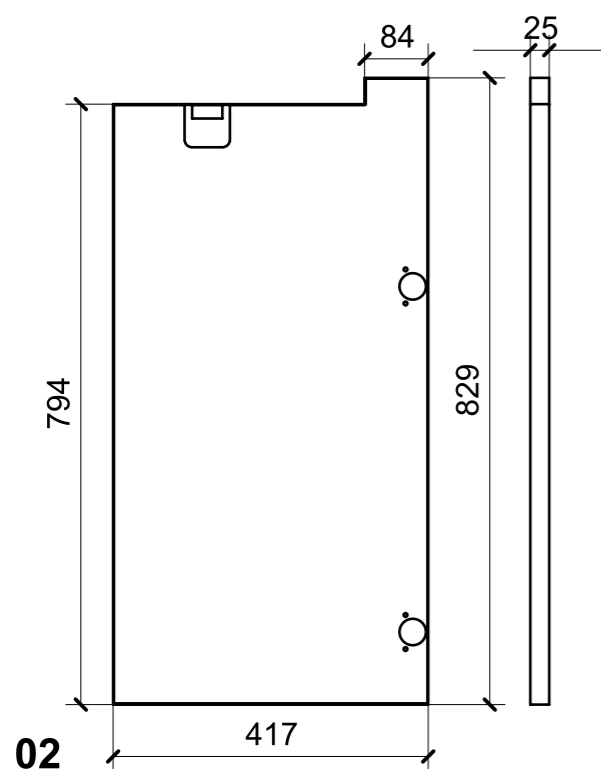
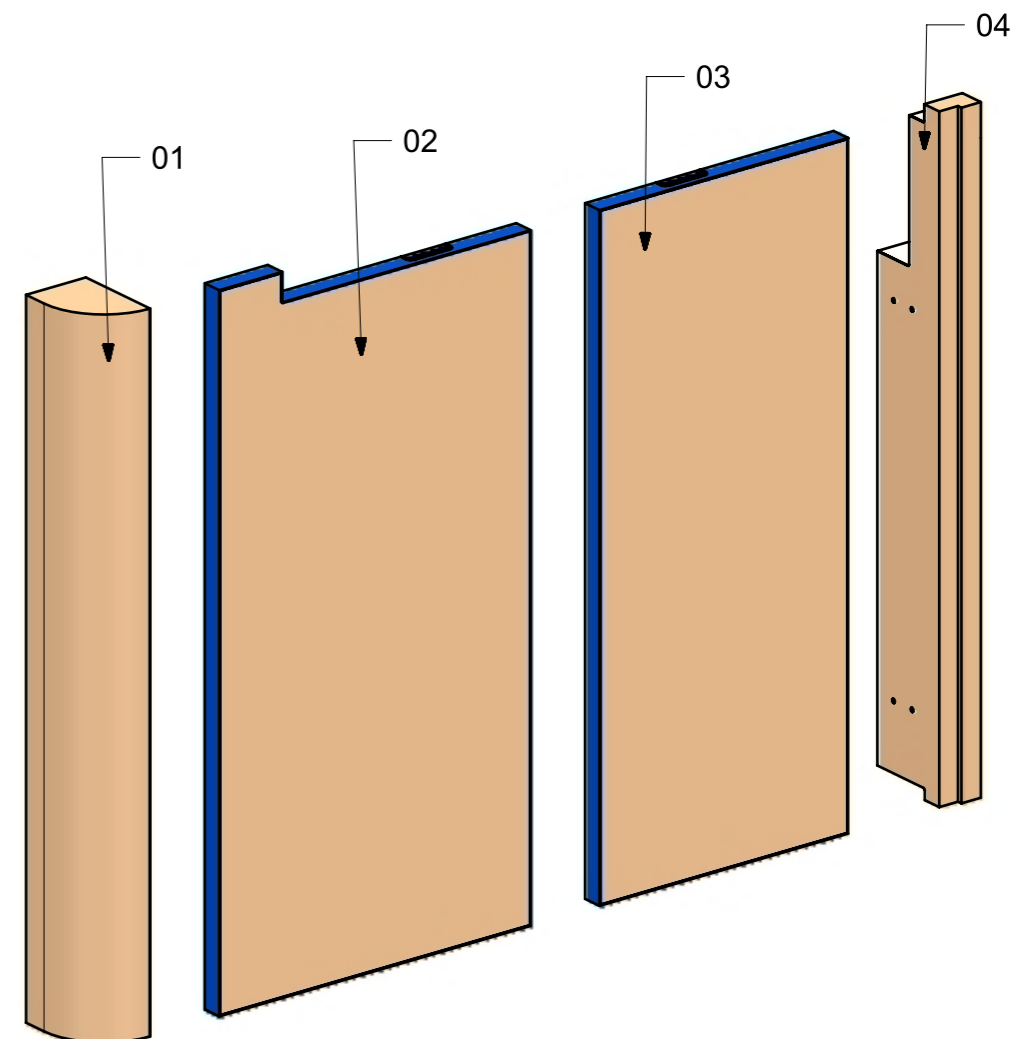
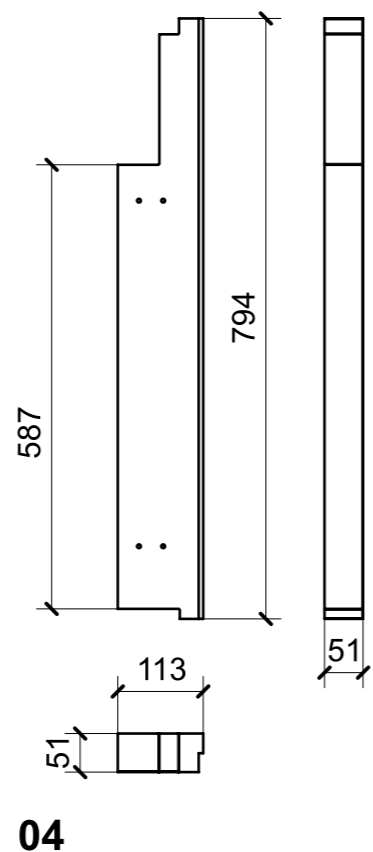
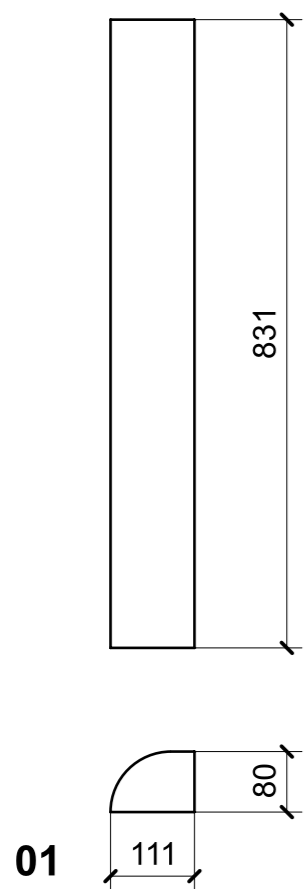

FERRAMENTA	QTY
BASE_0-NERA_HAFELE_342.22.065-BLUM_175H3100.STP	2
BUSSOLA 5MA ANKOR BORGHI	4
BUSSOLA 5MA ANKOR BORGHI X BASE 0	4
BUSSOLA 5MA ANKOR BORGHI X CERNIERA COLLO PIENO	4
BUSSOLA 6MA X 10 FORO DIAM.8	5
CERNIERA 95°_COLLO PIENO-NERA_HAFELE_342.46.606-BLUM_71B9750.STP	2
MANIGLIA AD INCASSO_FORESTI_ART 238 FINITURA BRUNITON	2
VITE 4MAX8 ANKOR BORGHI X BASE 0	4
VITE 4MAX8 ANKOR BORGHI X CERNIERA COLLO PIENO	4

VERNICIATURA LASTRA/LACCATI:

● = VERNICIARE 1 LATO + FILI RASATI O BORDATI

NESSUN SIMBOLO = VERNICIARE 2 LATI + FILI RASATI O BORDATI

LOCALE	CODICE	DESCRIZIONE COMPONENTE	FINITURA	GR.
CUCINA	MD321_R01_KC01	FRIGO	LAISTRA ALPI JAY STRIPED 12.35	2

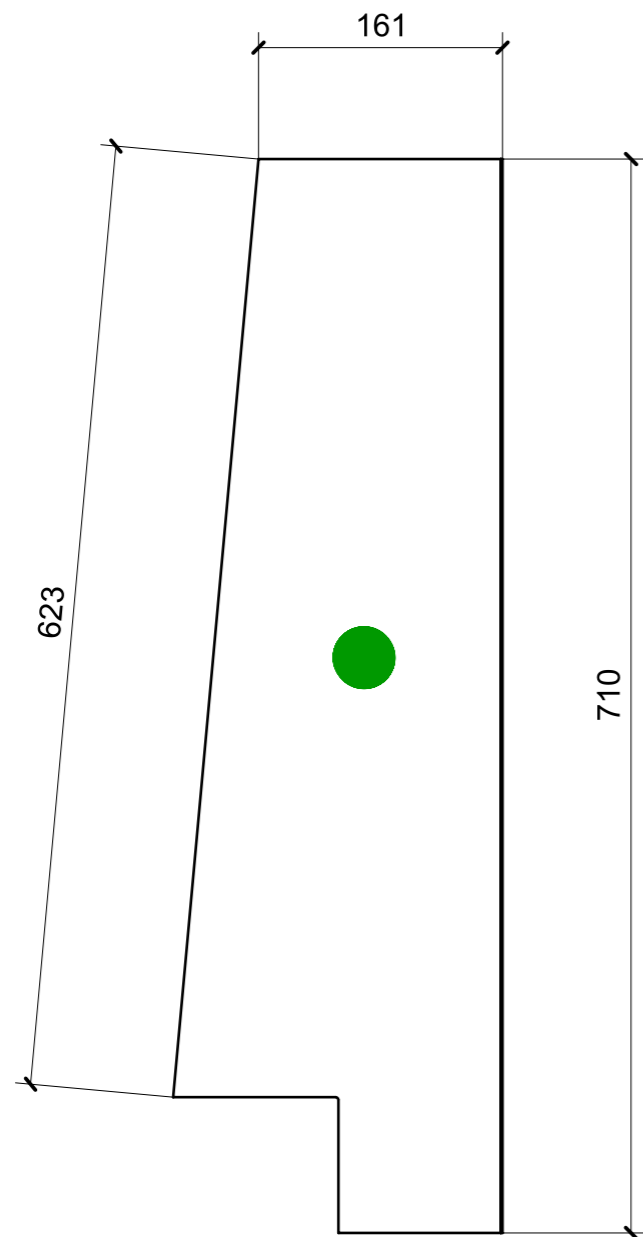

01

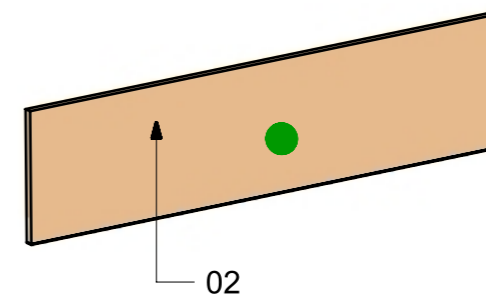

02

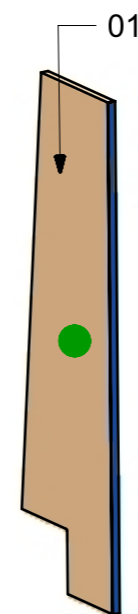

01

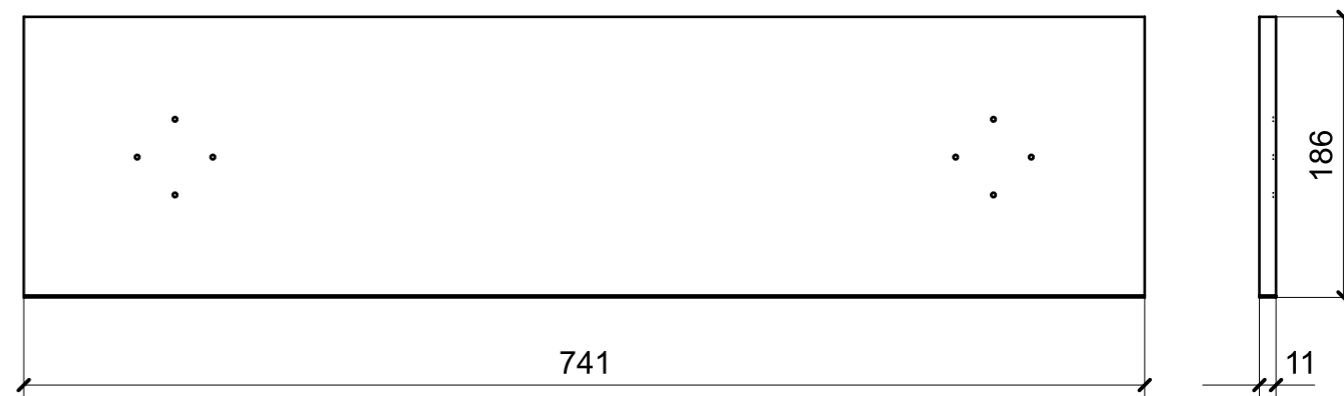

02

FERRAMENTA	QTY
FITLOCK M_MASCHERPA_3MM_6020202101	2

VERNICIATURA LASTRA/LACCATI:

● = VERNICIARE 1 LATO + FILI RASATI O BORDATI

NESSUN SIMBOLO = VERNICIARE 2 LATI + FILI RASATI O BORDATI

LOCALE	CODICE	DESCRIZIONE COMPONENTE	FINITURA	GR.
CUCINA	MD321_R01_KKC01	FRIGO AD INCASSO PICCOLO VAR.1	LASTRA ALPI JAY STRIPED 12.35	2

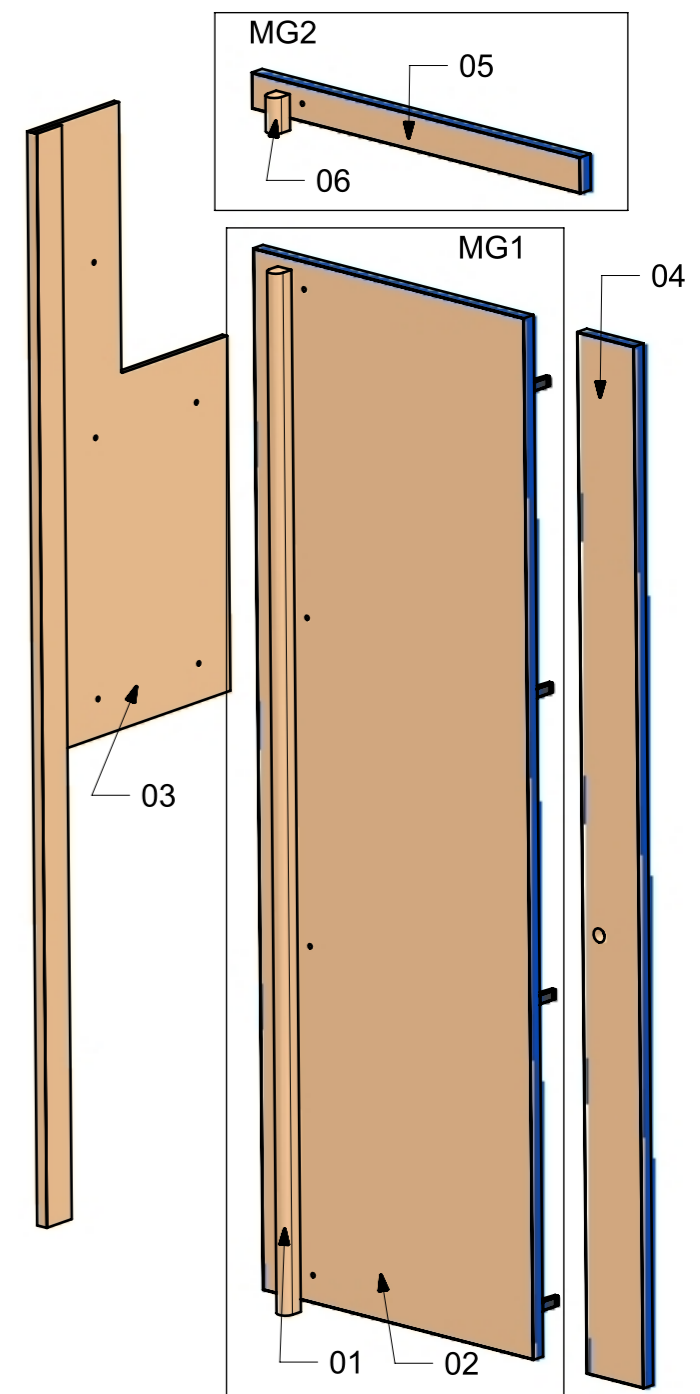
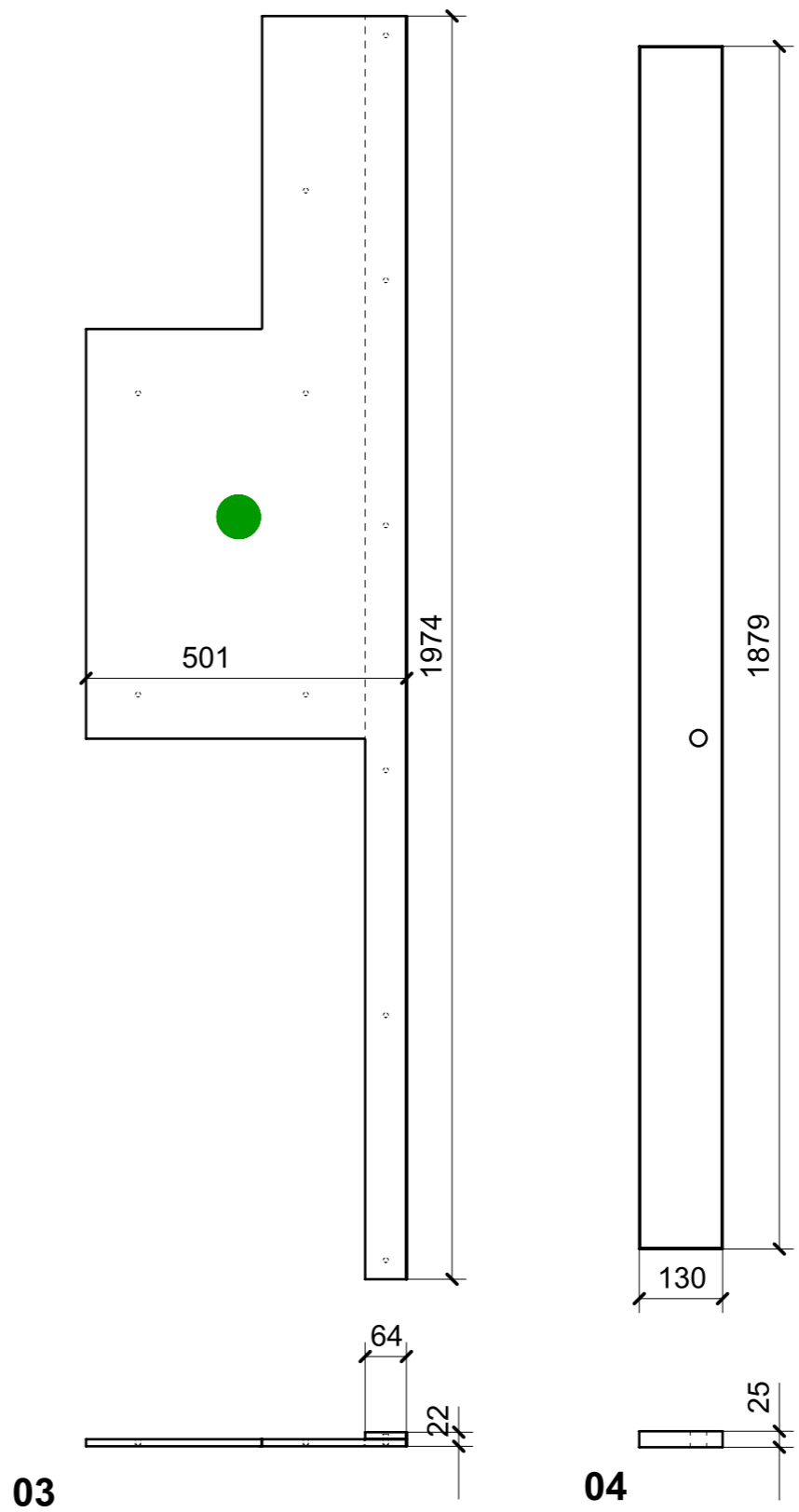
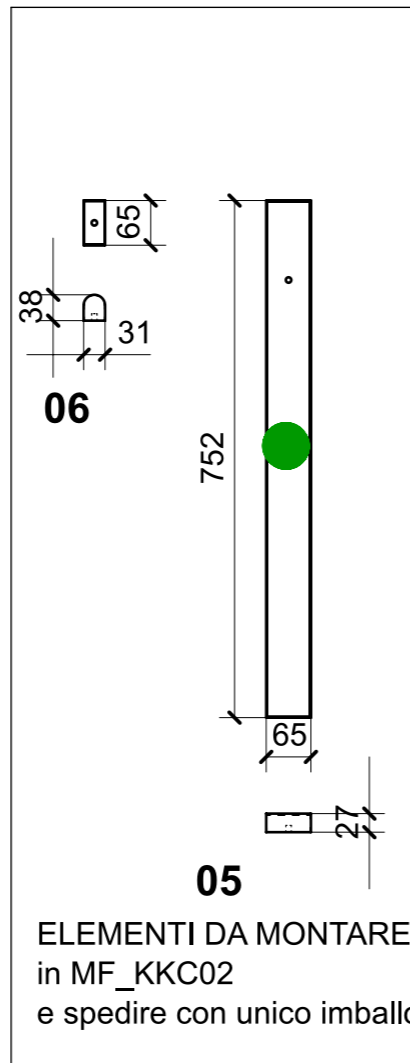
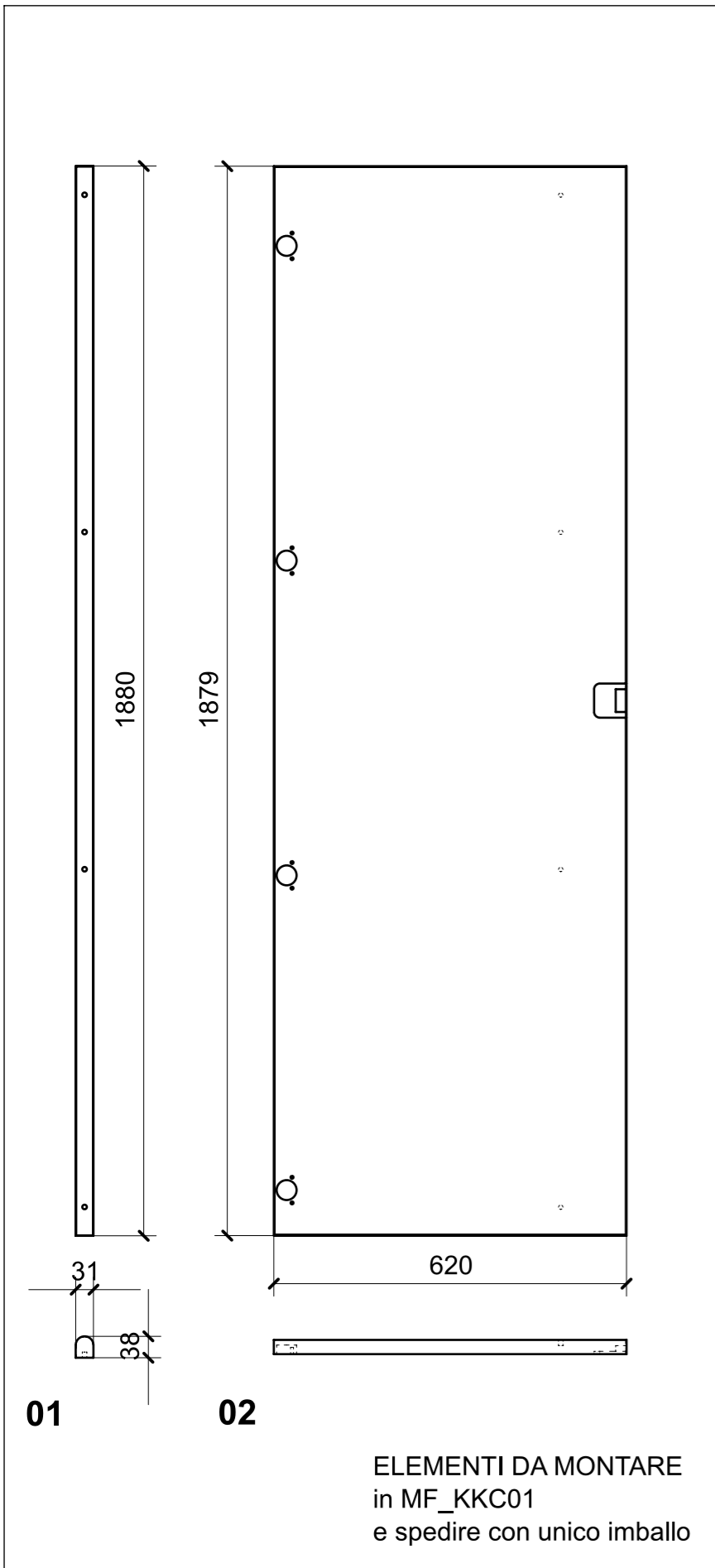

VERNICIATURA LASTRA/LACCATI:

● = VERNICIARE 1 LATO + FILI RASATI O BORDATI

NESSUN SIMBOLO = VERNICIARE 2 LATI + FILI RASATI O BORDATI

LOCALE	CODICE	DESCRIZIONE COMPONENTE	FINITURA	GR.
CUCINA	MD321_R01_KCC01	FRIGO INOX AMERICANO VAR.2	LASTRA ALPI JAY STRIPED 12.35	2

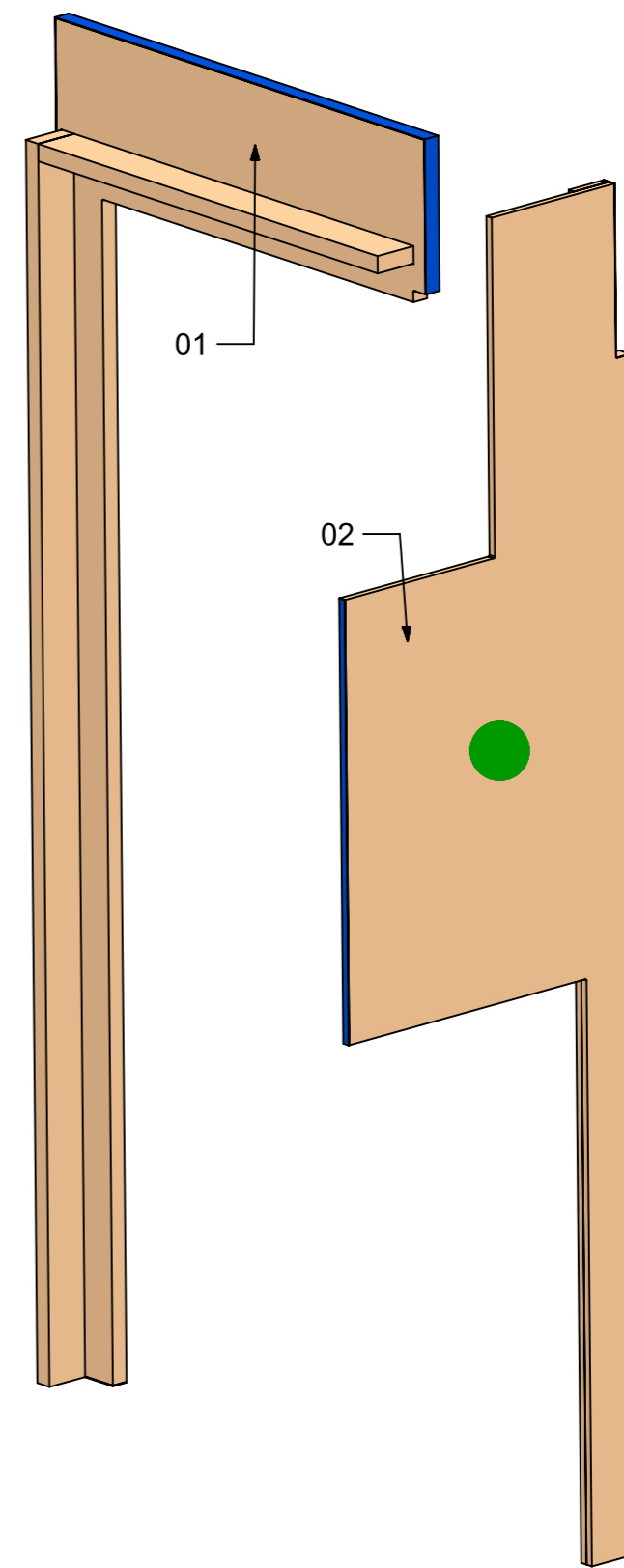
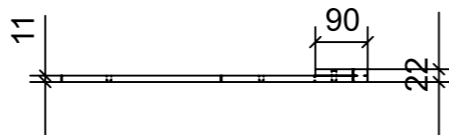
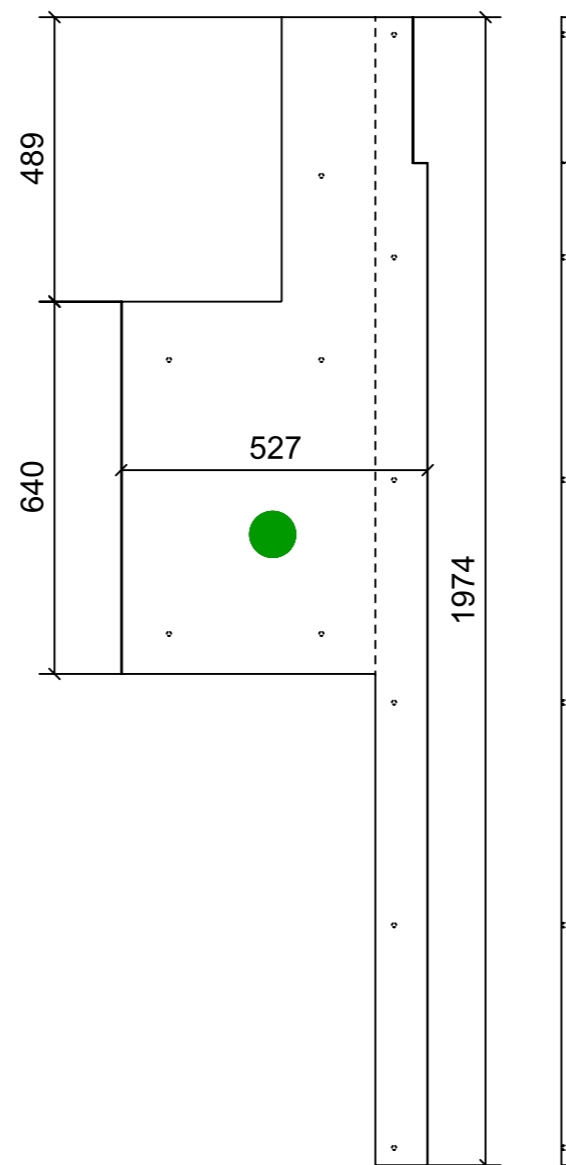
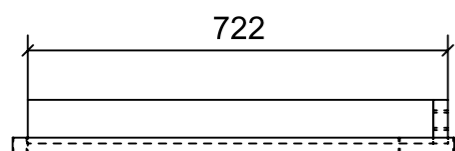
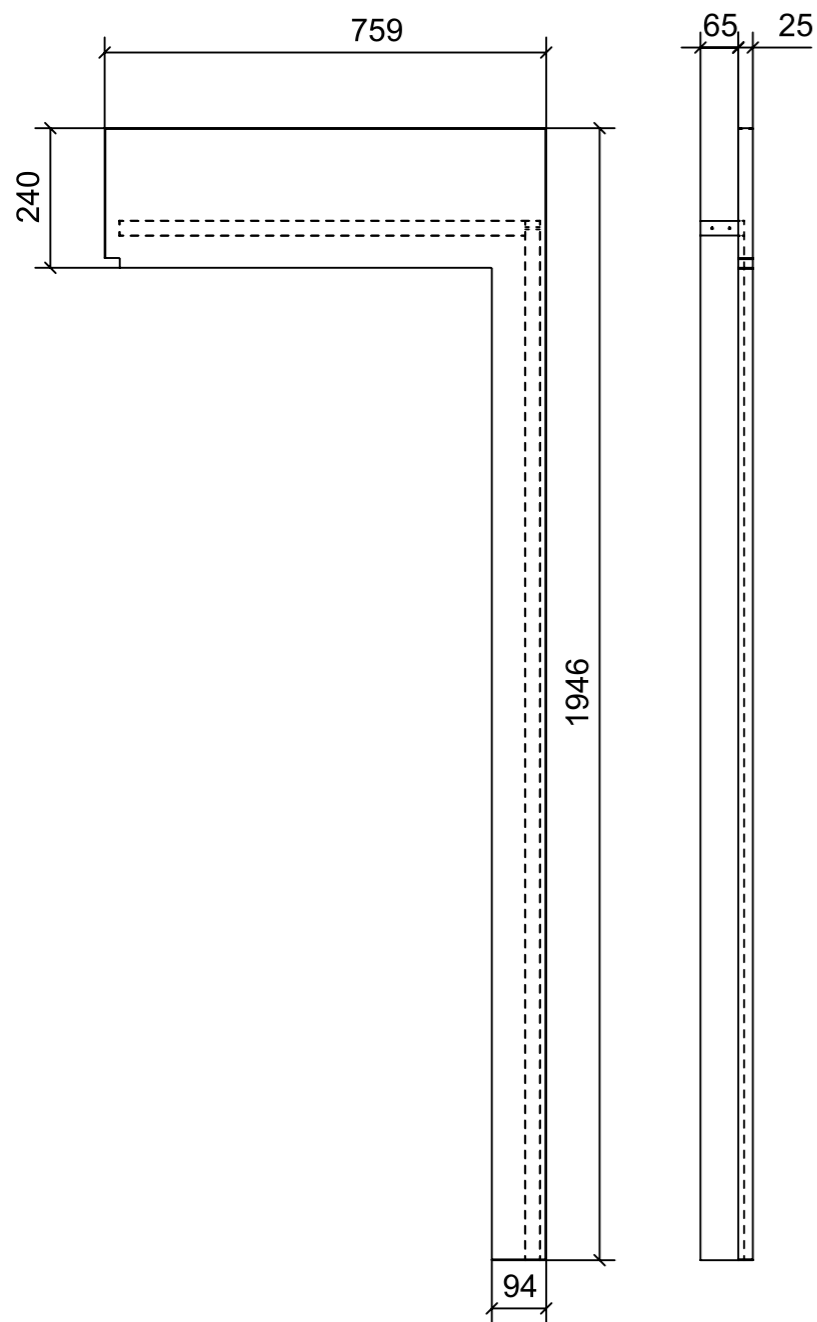

01

02

VERNICIATURA LASTRA/LACCATI:

● = VERNICIARE 1 LATO + FILI RASATI O BORDATI

NESSUN SIMBOLO = VERNICIARE 2 LATI + FILI RASATI O BORDATI

LOCALE	CODICE	DESCRIZIONE COMPONENTE	FINITURA	GR.
CUCINA	MD321_R01_KD01	PENSILE A MURATA	LASTRA ALPI JAY STRIPED 12.35	2

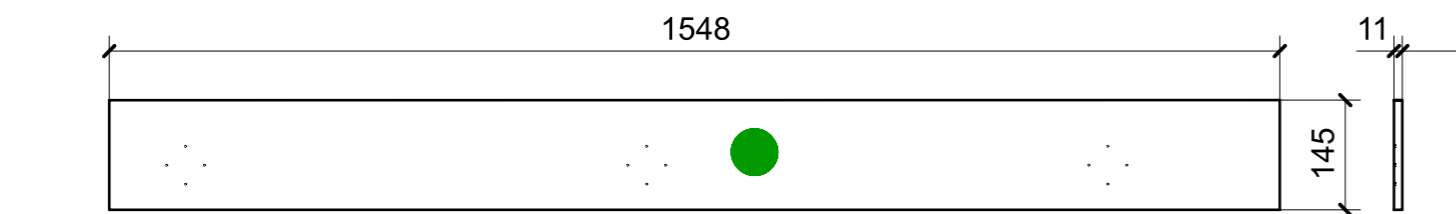

01

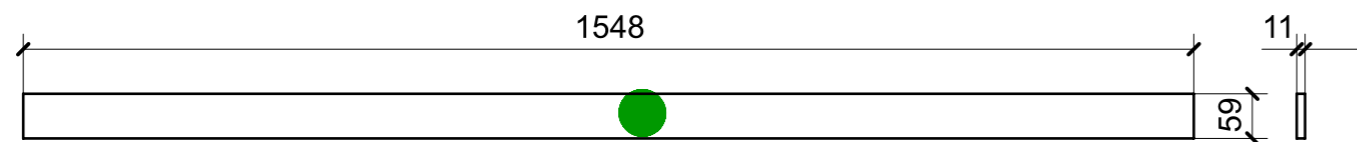

02

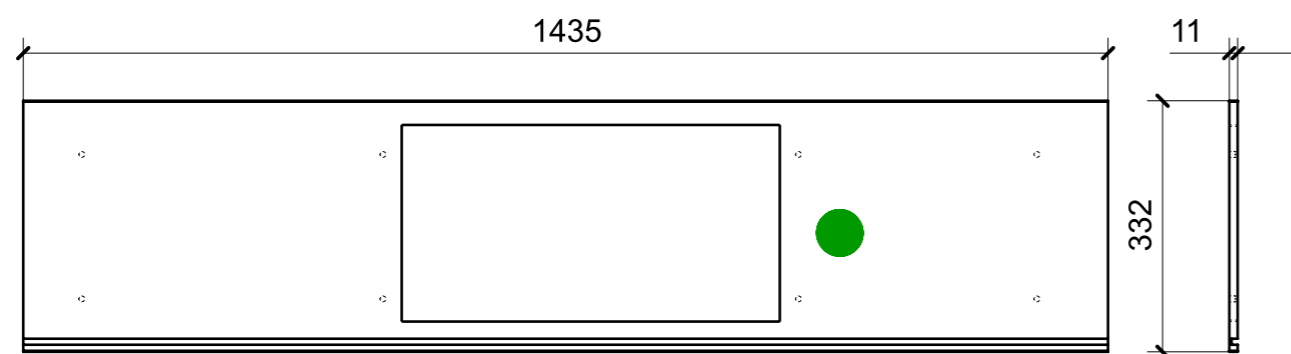

03

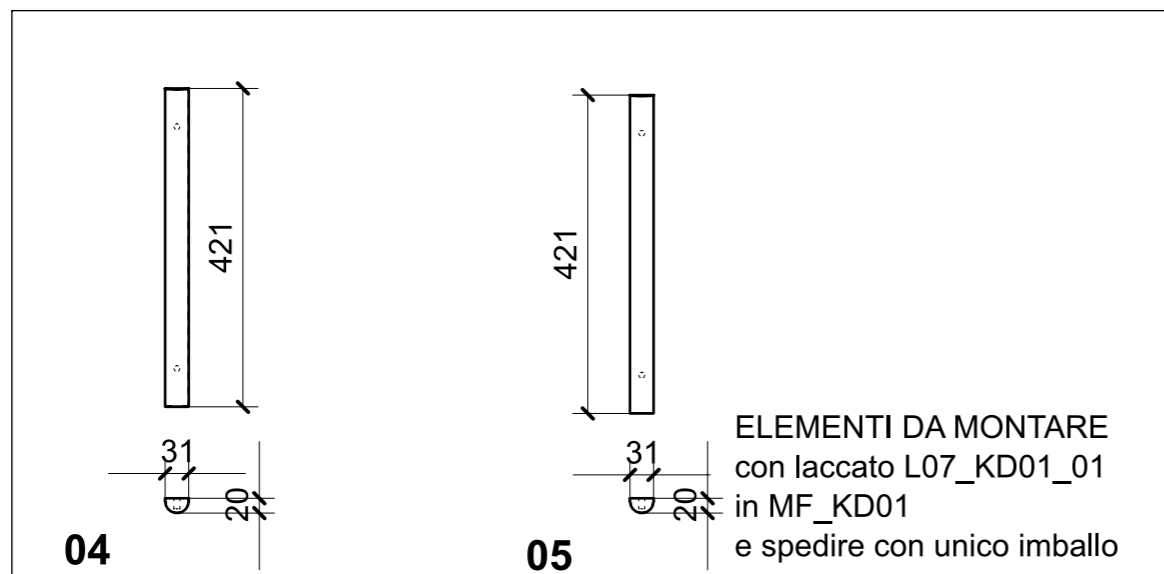

04

05

ELEMENTI DA MONTARE
con laccato L07_KD01_01
in MF_KD01
e spedire con unico imballo

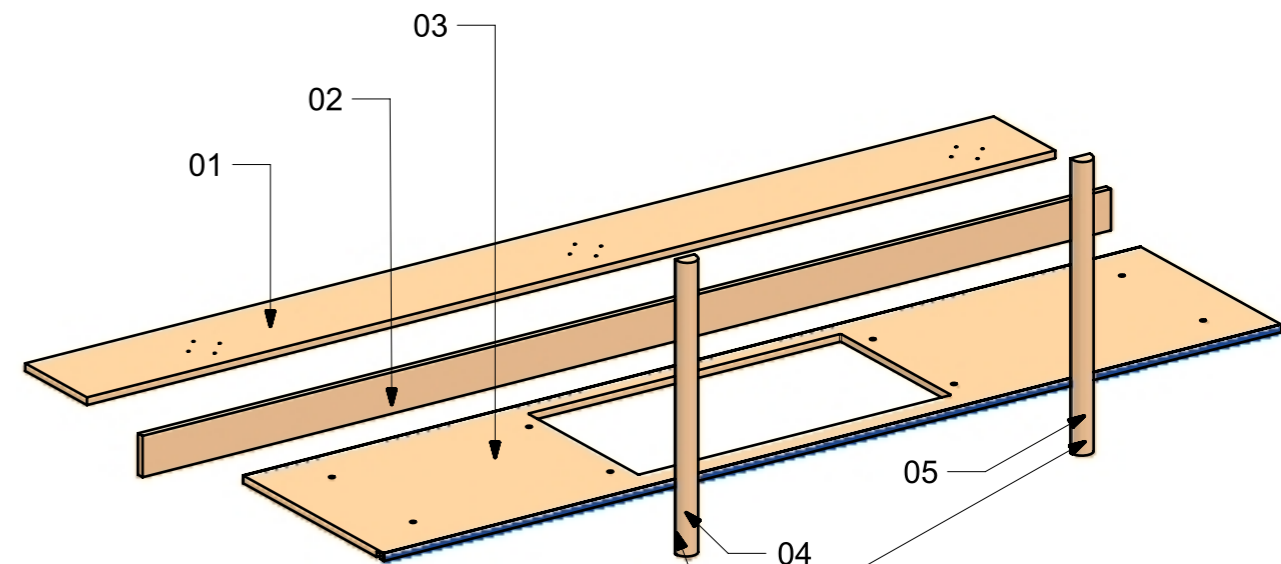

ELEMENTI DA MONTARE
con laccato L07_KD01_01
in MF_KD01
e spedire con unico imballo

FERRAMENTA	QTY
FITLOCK M_MASCHERPA_3MM_6020202101	3

VERNICIATURA LASTRA/LACCATI:

● = VERNICIARE 1 LATO + FILI RASATI O BORDATI

NESSUN SIMBOLO = VERNICIARE 2 LATI + FILI RASATI O BORDATI

LOCALE	CODICE	DESCRIZIONE COMPONENTE	FINITURA	GR.
CUCINA	MD321_R01_KE01	PENSILE LATO PRUA	LASTRA ALPI JAY STRIPED 12.35	2

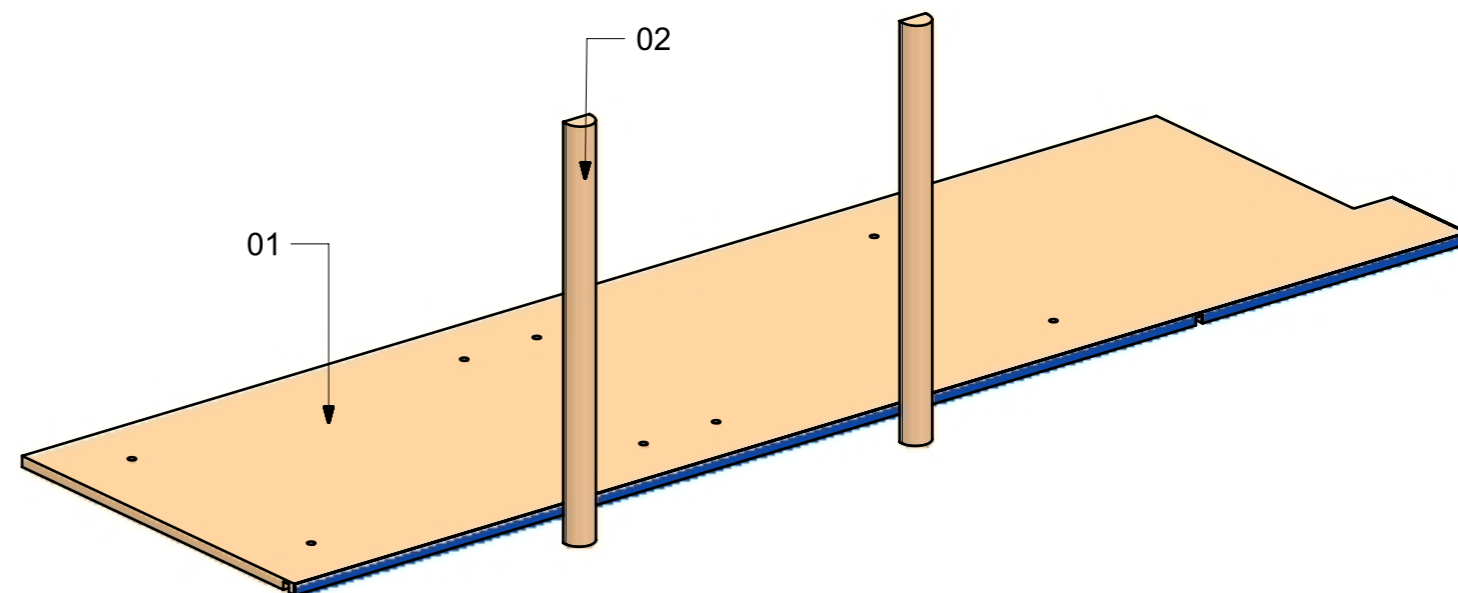
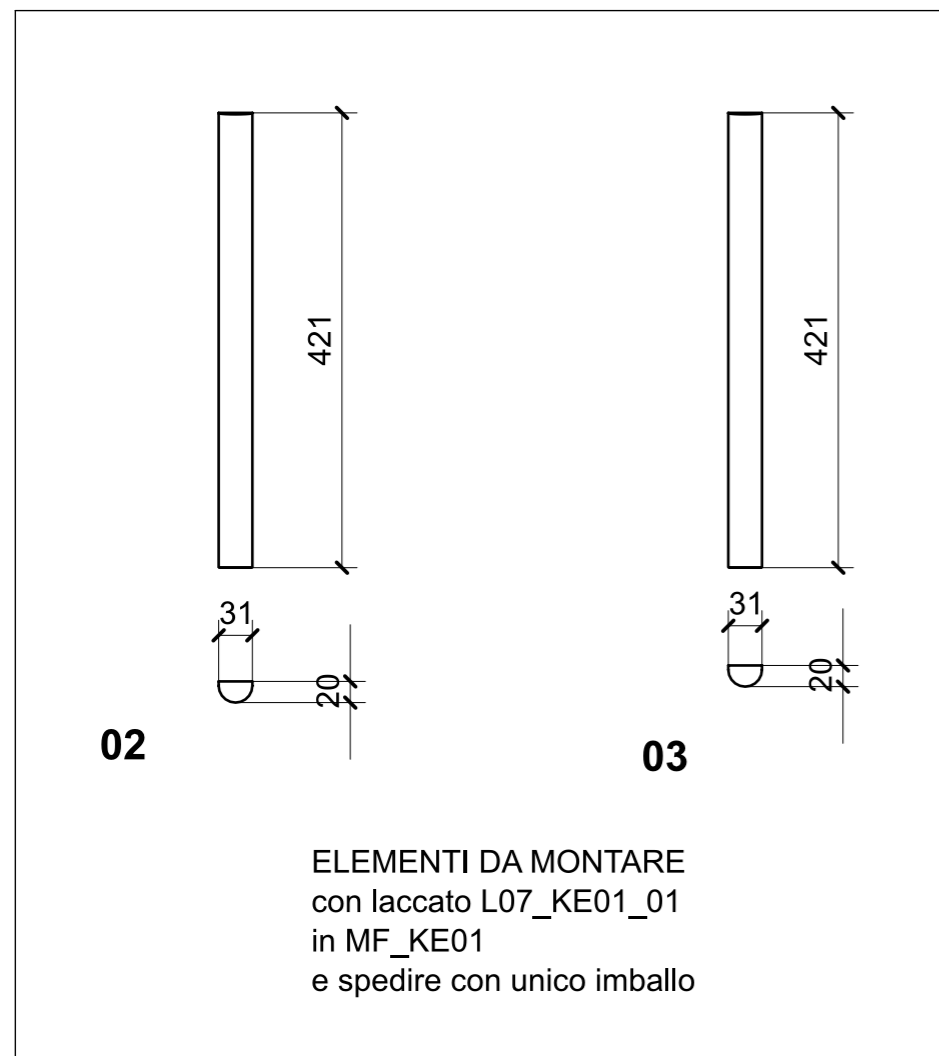
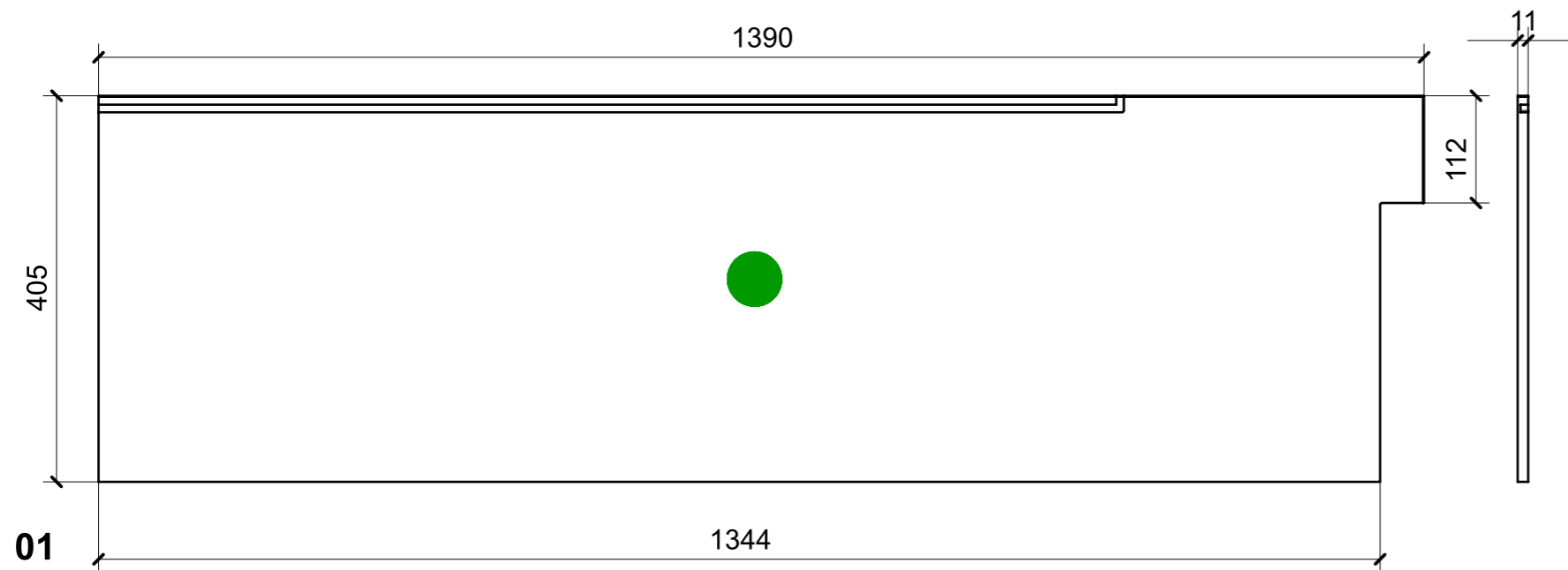

VERNICIATURA LASTRA/LACCATI:

● = VERNICIARE 1 LATO + FILI RASATI O BORDATI

NESSUN SIMBOLO = VERNICIARE 2 LATI + FILI RASATI O BORDATI

LOCALE	CODICE	DESCRIZIONE COMPONENTE	FINITURA	GR.
CUCINA	MD321_R01_KG01	ANGOLO MURATA	LAISTRA ALPI JAY STRIPED 12.35	2

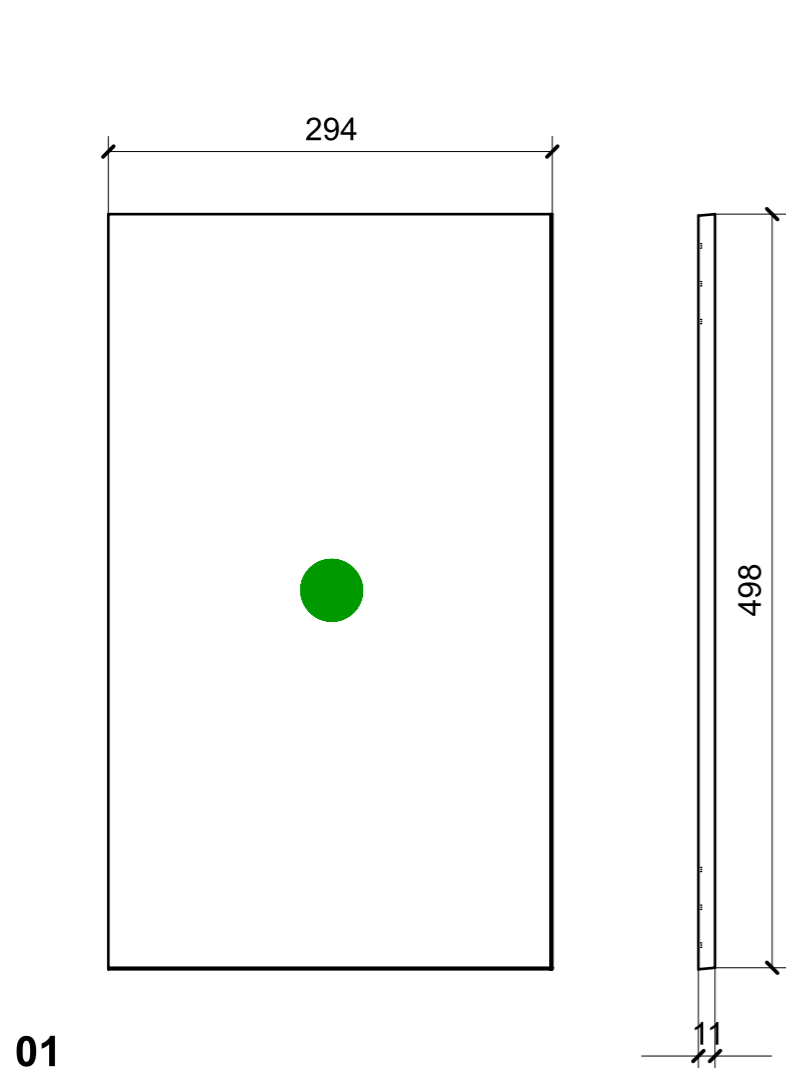

01

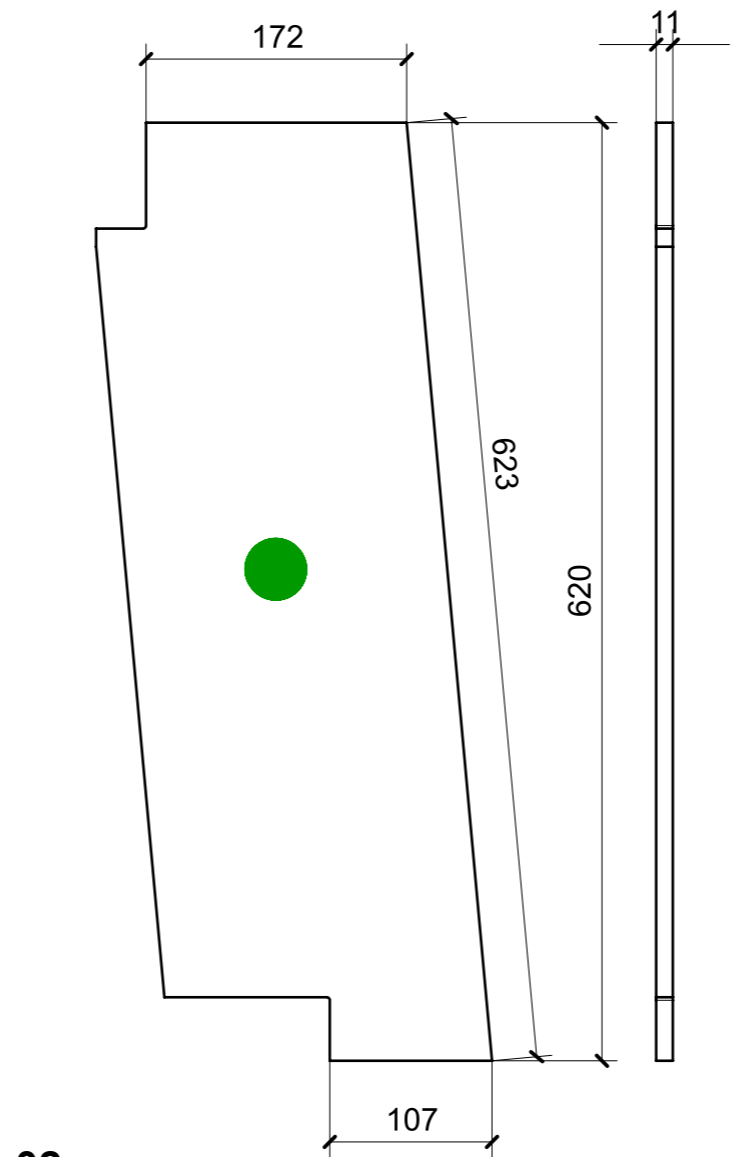

02

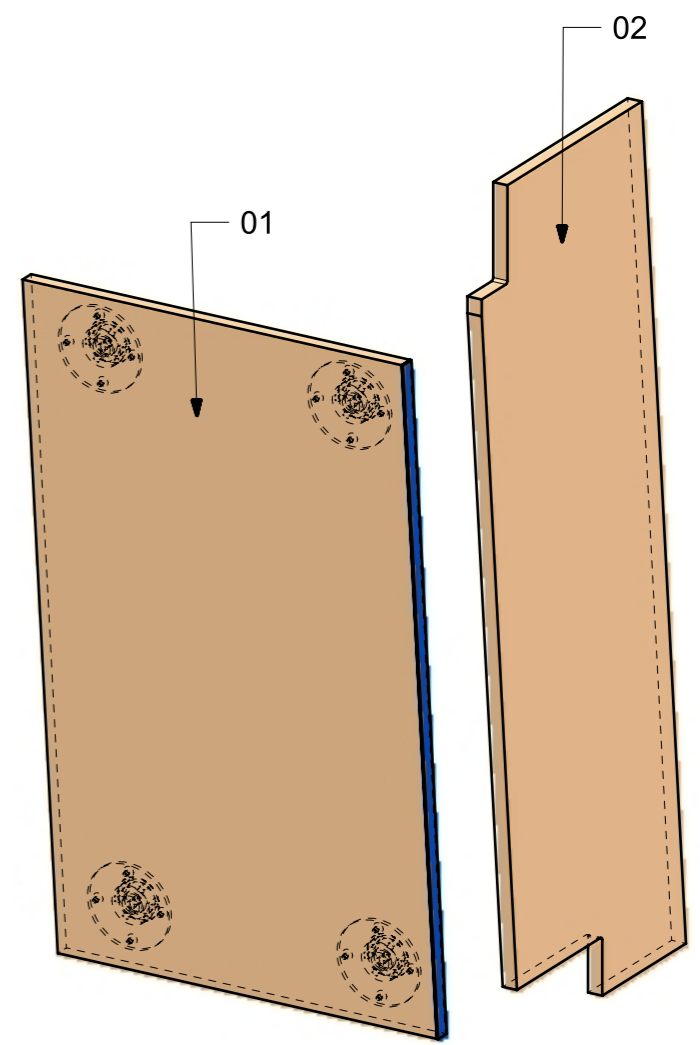

FERRAMENTA	QTY
FITLOCK M_MASCHERPA_3MM_6020202101	4

VERNICIATURA LASTRA/LACCATI:
 ● = VERNICIARE 1 LATO + FILI RASATI O BORDATI NESSUN SIMBOLO = VERNICIARE 2 LATI + FILI RASATI O BORDATI

LOCALE	CODICE	DESCRIZIONE COMPONENTE	FINITURA	GR.
CUCINA	MD321_R01_KI01	PARETE DIVISORIA GUIDA-CUCINA	LASTRA ALPI JAY STRIPED 12.35	PTP

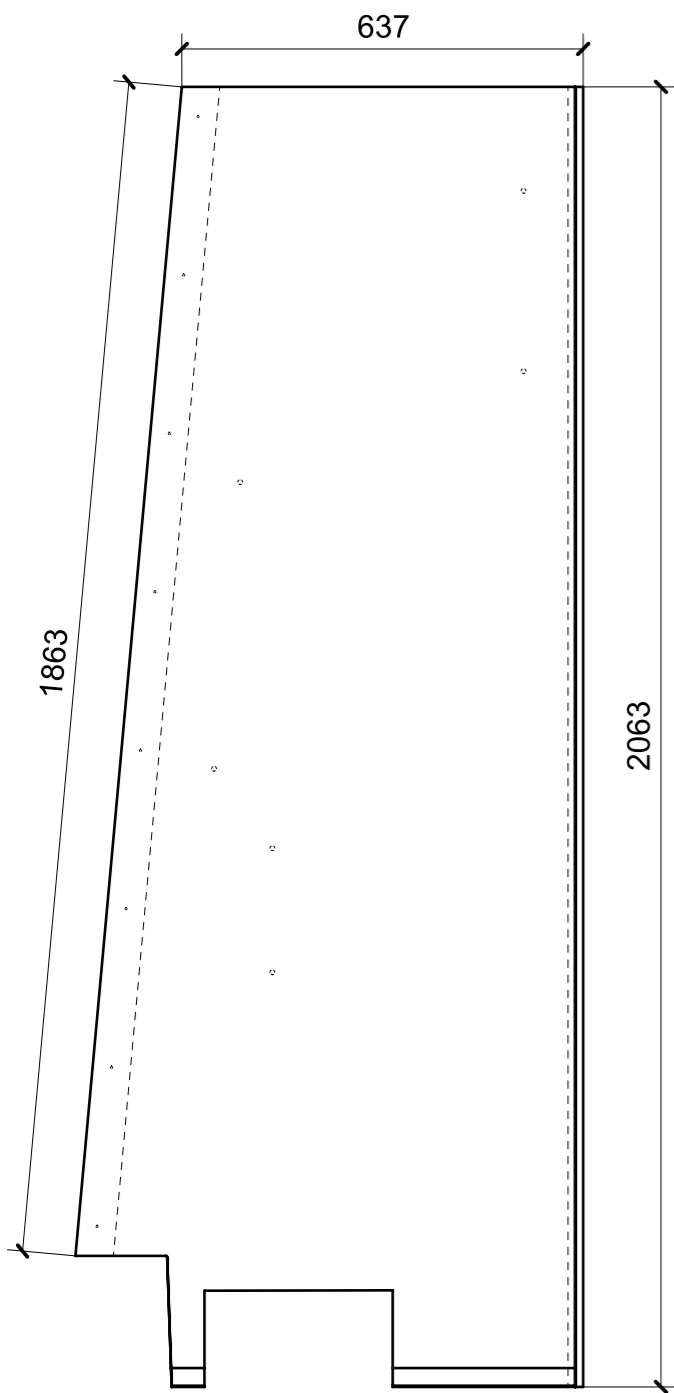

01

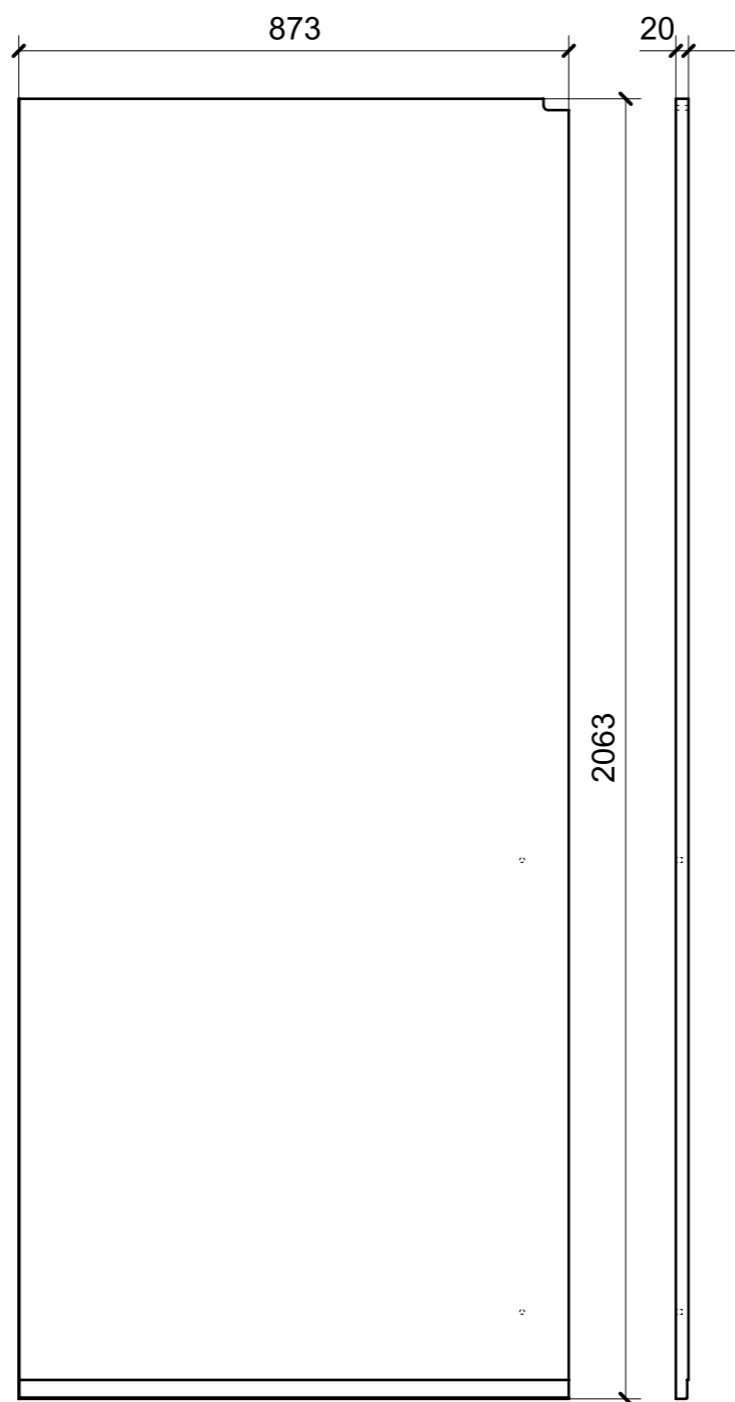

02

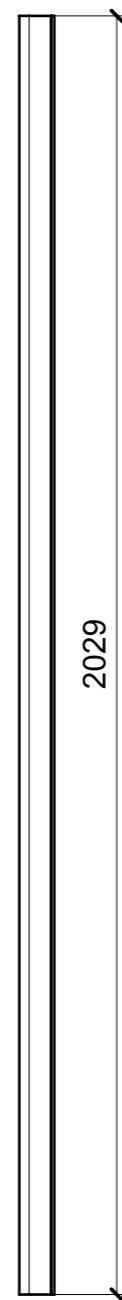

03

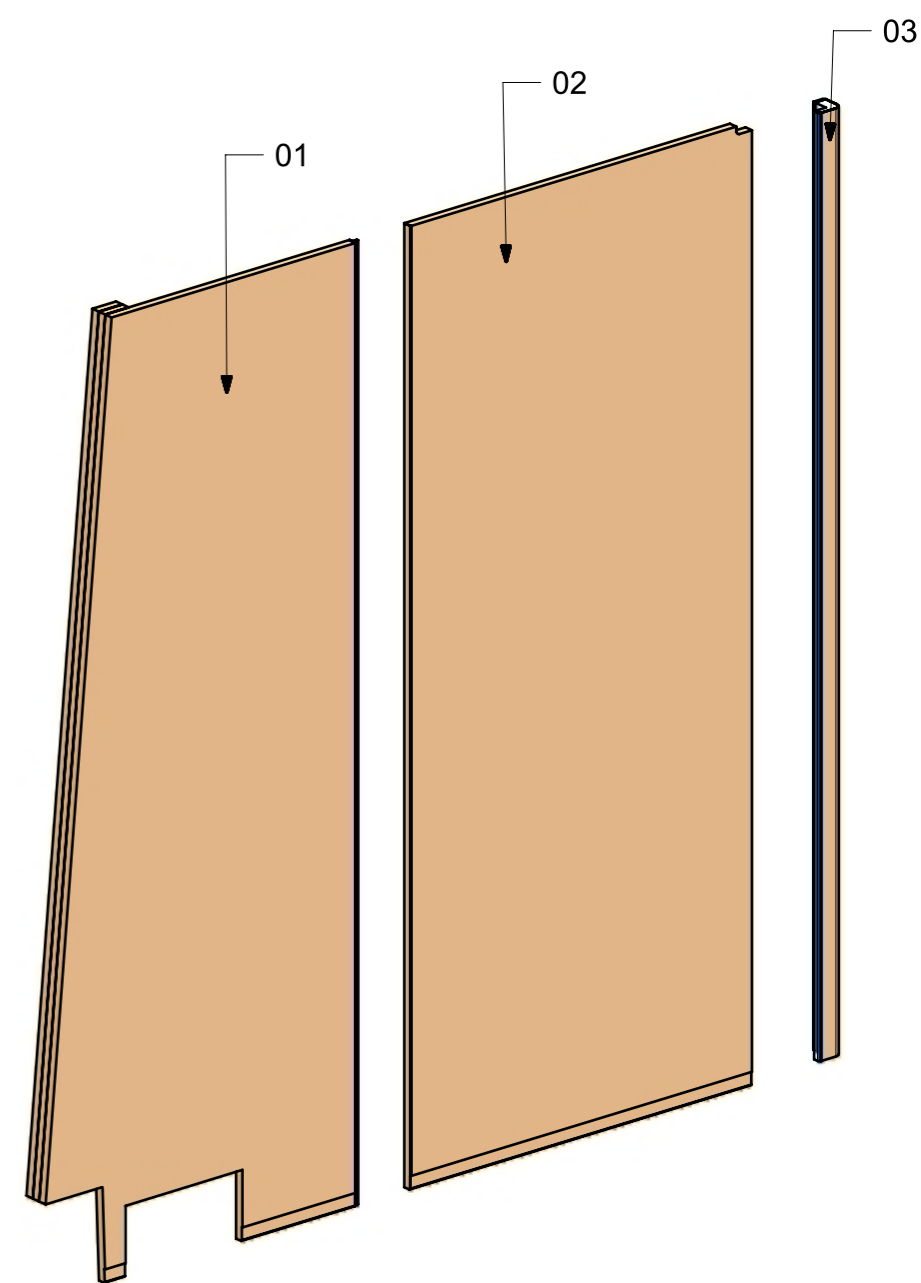
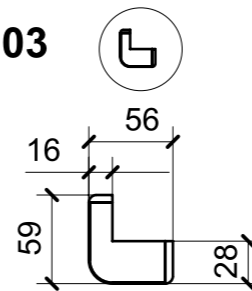

FERRAMENTA	QTY
BUSSOLA 6MA X 10 FORO DIAM.8	8

VERNICIATURA LASTRA/LACCATI:

● = VERNICIARE 1 LATO + FILI RASATI O BORDATI

NESSUN SIMBOLO = VERNICIARE 2 LATI + FILI RASATI O BORDATI

LOCALE	CODICE	DESCRIZIONE COMPONENTE	FINITURA	GR.
CUCINA	MD321_R01_KL01	MURETTO CENTRO NAVE STD. VAR.1	LASTRA ALPI JAY STRIPED 12.35	PTP

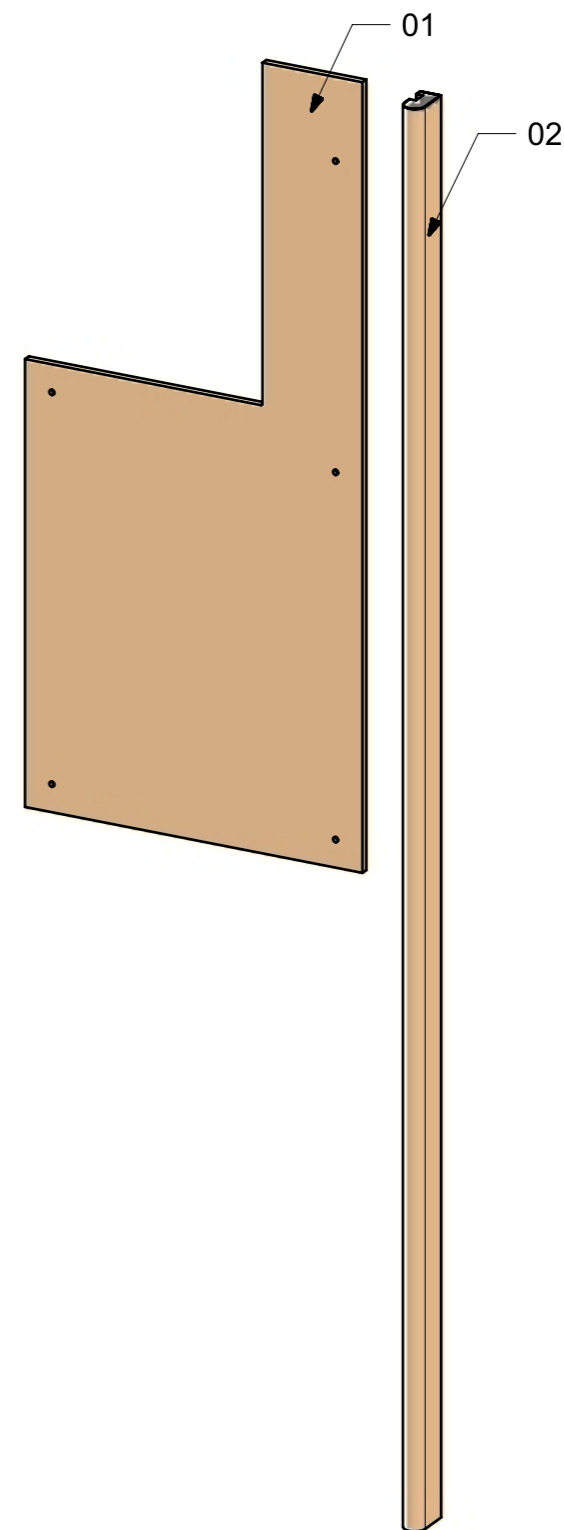
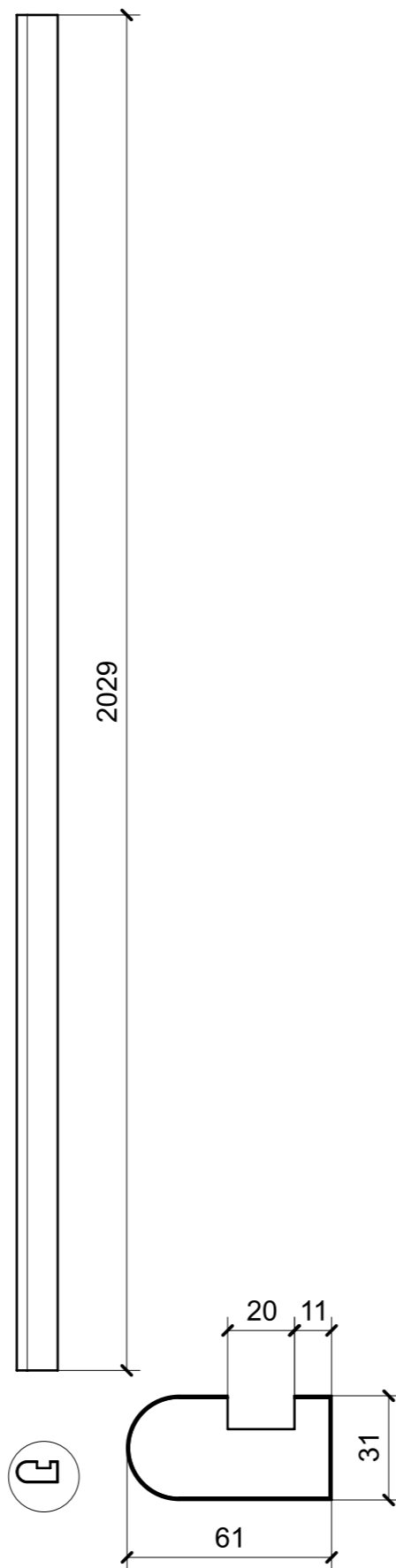
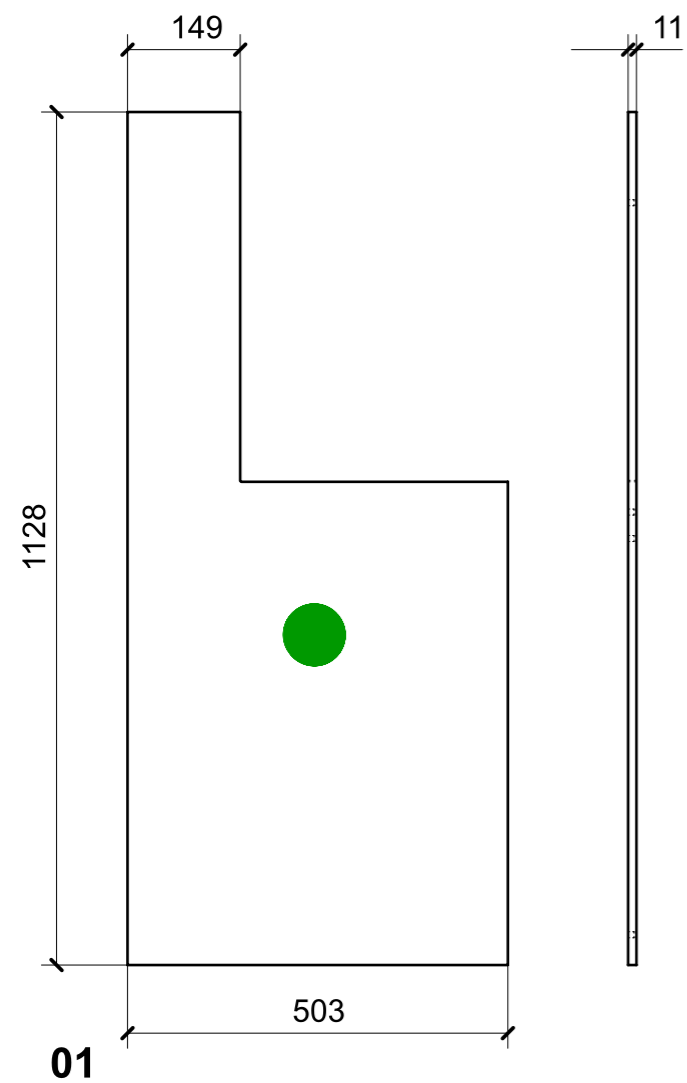

VERNICIATURA LASTRA/LACCATI:

● = VERNICIARE 1 LATO + FILI RASATI O BORDATI

NESSUN SIMBOLO = VERNICIARE 2 LATI + FILI RASATI O BORDATI

LOCALE	CODICE	DESCRIZIONE COMPONENTE	FINITURA	GR.
CUCINA	MD321_R02_KL01	MURETTO CENTRO NAVE STD. VAR.1	LASTRA ALPI JAY FLAMED 12.34	PTP

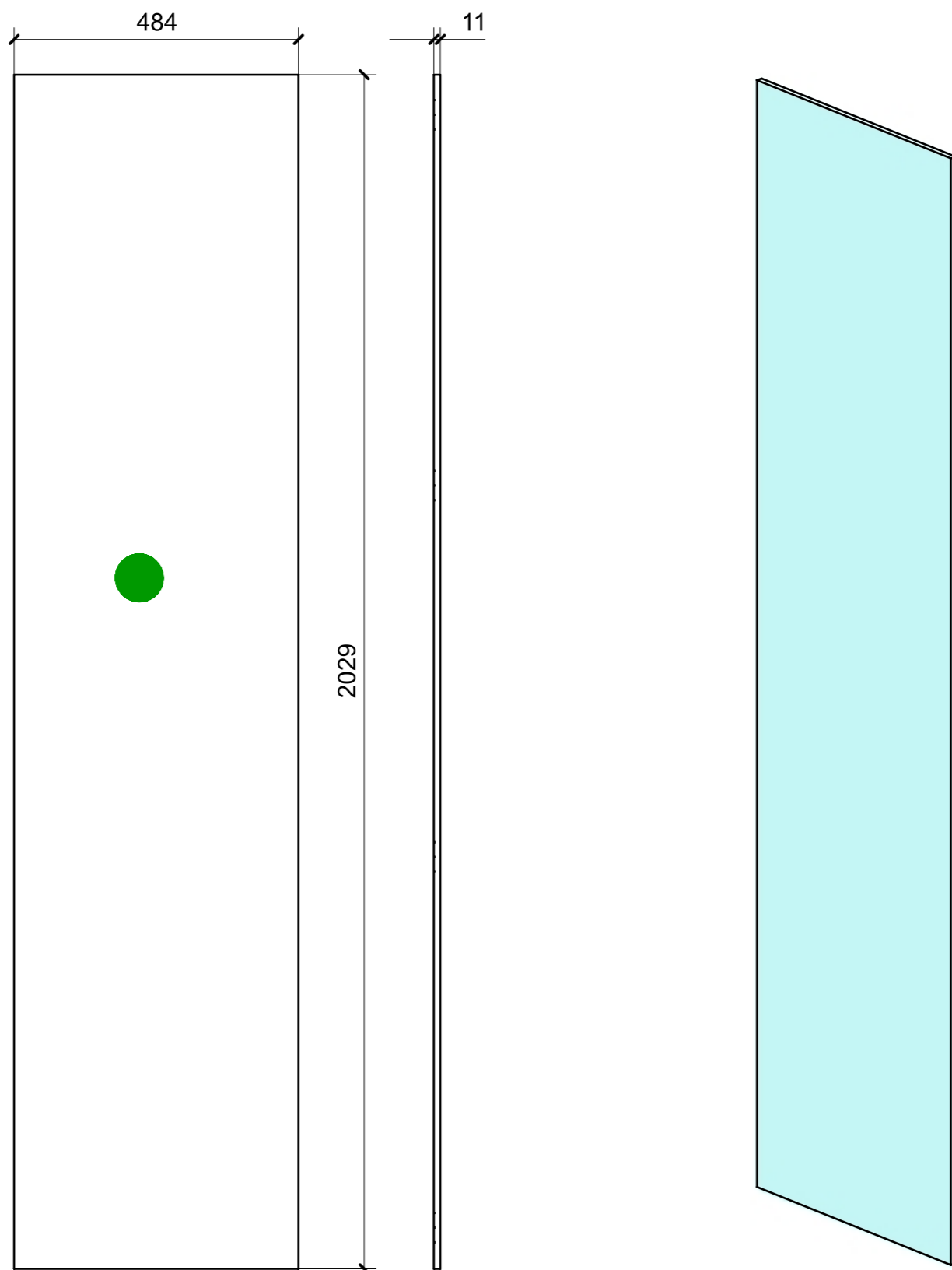

01

FERRAMENTA	QTY
FITLOCK M_MASCHERPA_3MM_6020202101	8

VERNICIATURA LASTRA/LACCATI:

● = VERNICIARE 1 LATO + FILI RASATI O BORDATI

NESSUN SIMBOLO = VERNICIARE 2 LATI + FILI RASATI O BORDATI

LOCALE	CODICE	DESCRIZIONE COMPONENTE	FINITURA	GR.
CUCINA	MD321_R01_KM01	SEPARE' CUCINA-SALONE	LAISTRA ALPI JAY STRIPED 12.35	2

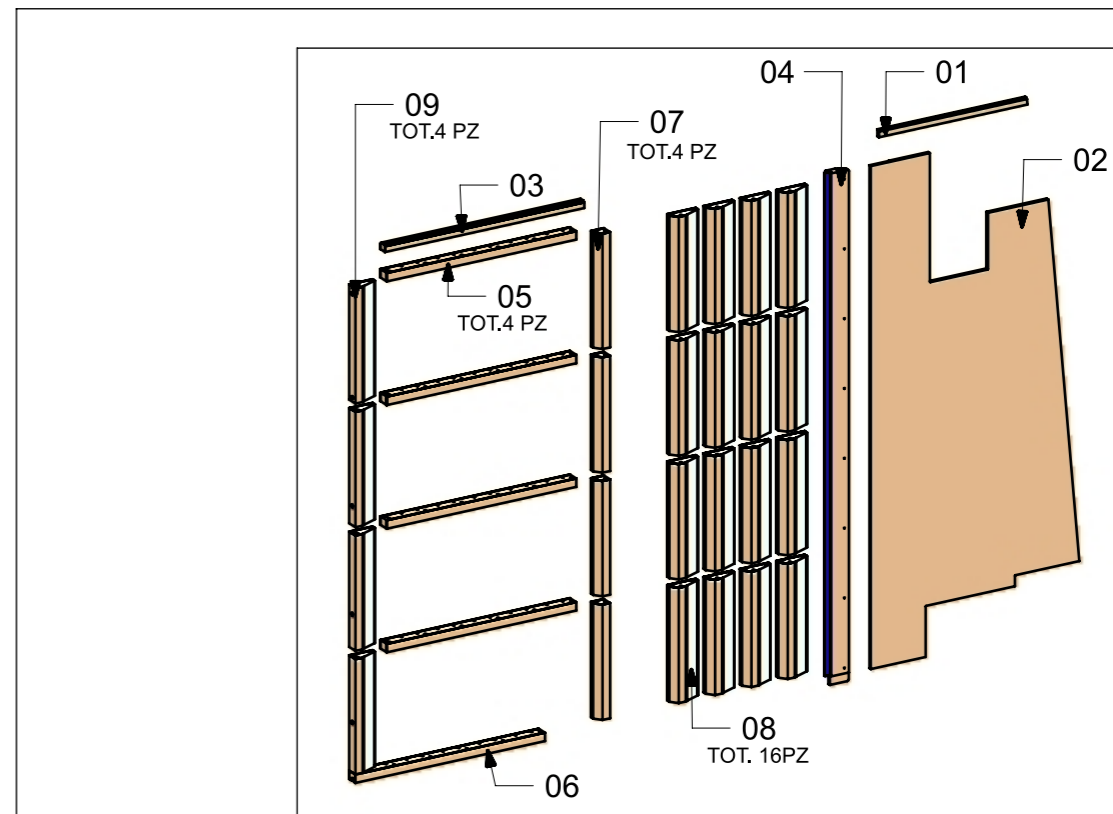
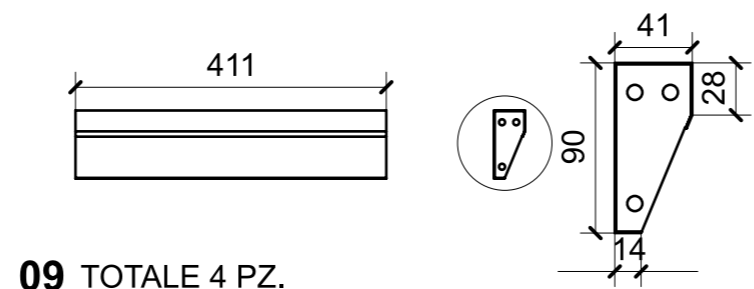
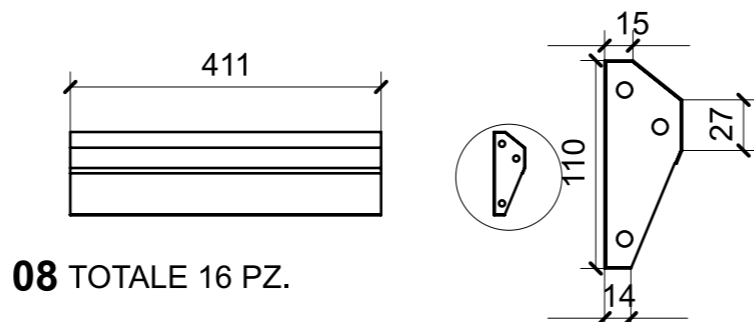
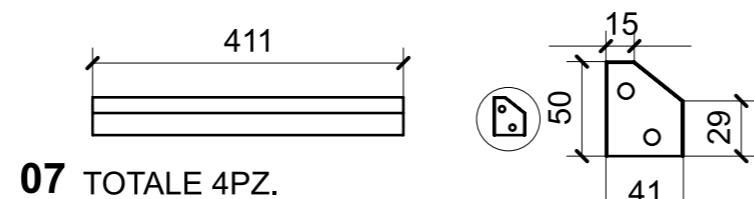
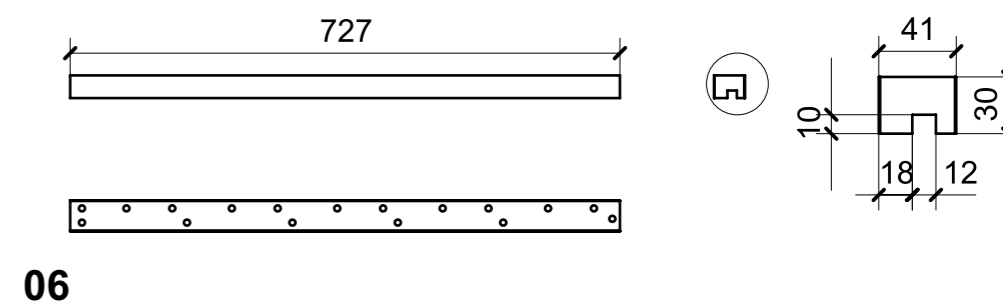
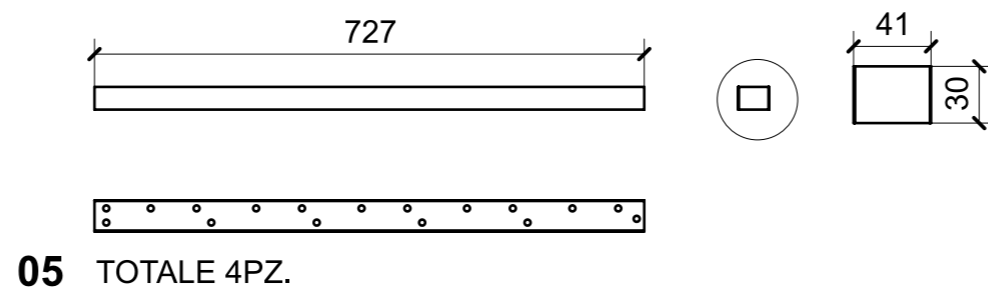
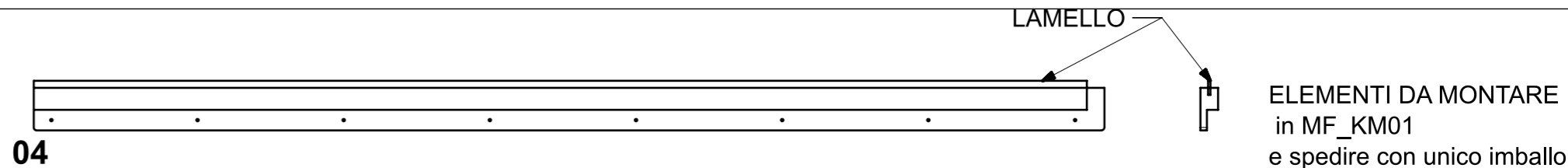
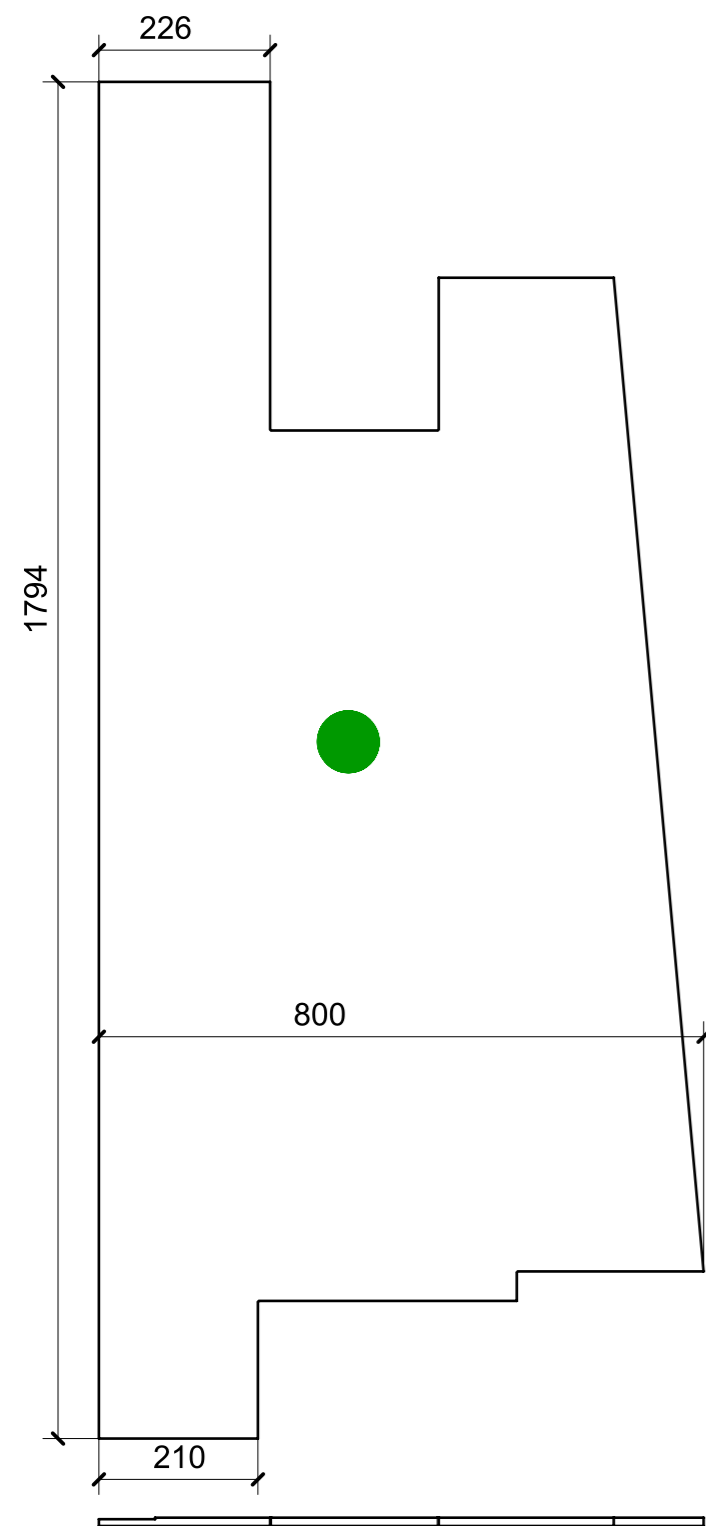
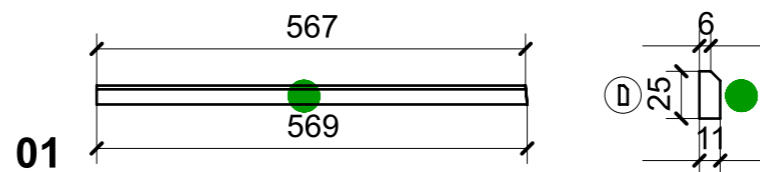
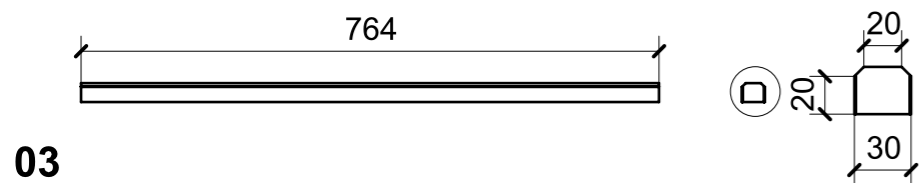

VERNICIATURA LASTRA/LACCATI:

● = VERNICIARE 1 LATO + FILI RASATI O BORDATI

NESSUN SIMBOLO = VERNICIARE 2 LATI + FILI RASATI O BORDATI

LOCALE	CODICE	DESCRIZIONE COMPONENTE	FINITURA	GR.
CUCINA	MD321_R01_KN01	MASSELLO CHIUSURA SEPRE' STD.VAR.1	LASTRA ALPI JAY STRIPED 12.35	PTP

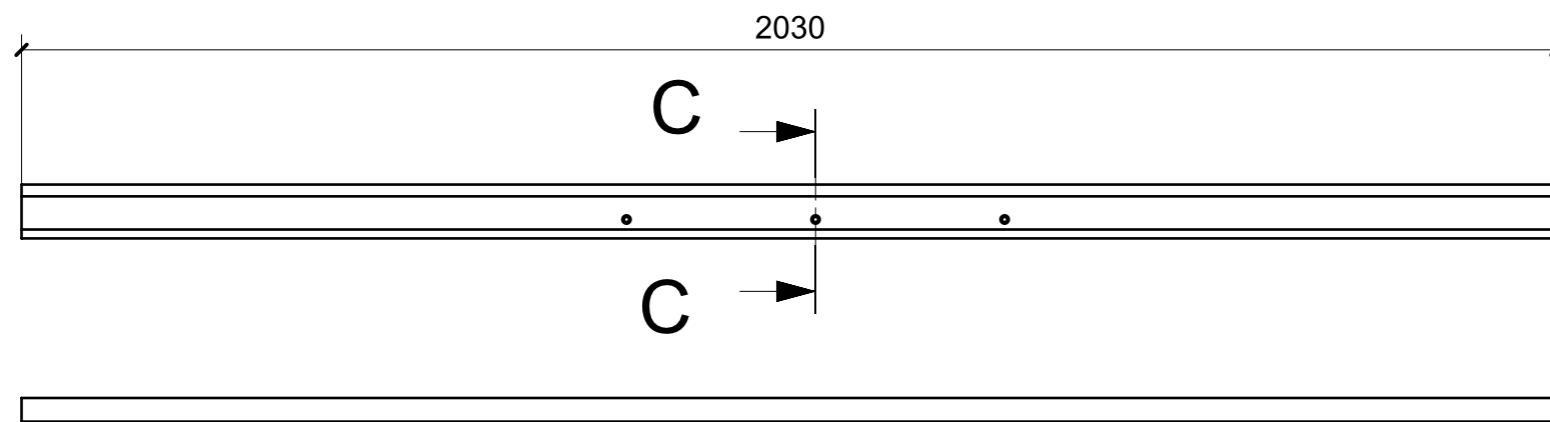

01

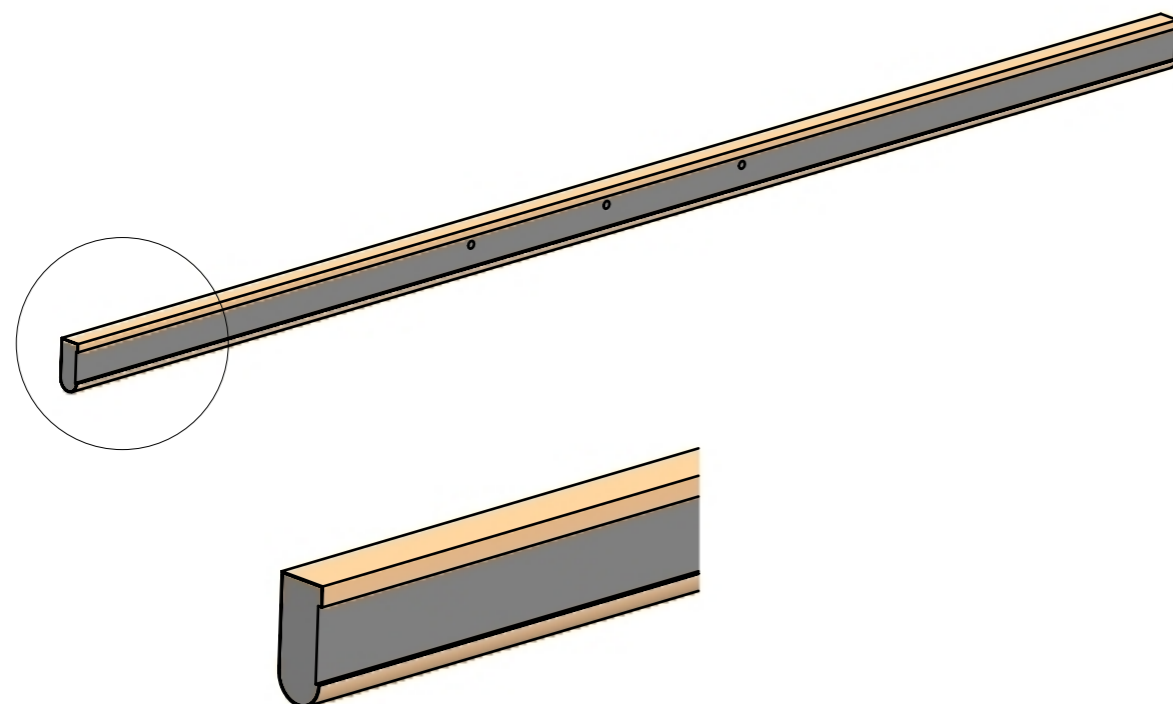
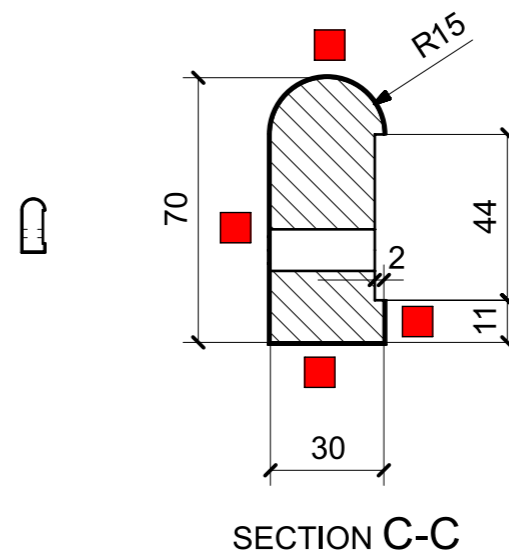

VERNICIATURA LASTRA/LACCATI:

● = VERNICIARE 1 LATO + FILI RASATI O BORDATI

NESSUN SIMBOLO = VERNICIARE 2 LATI + FILI RASATI O BORDATI

LOCALE	CODICE	DESCRIZIONE COMPONENTE	FINITURA	GR.
CUCINA	MD321_R01_KKL01	MURETTO CENTRO NAVE STD.VAR.2	LASTRA ALPI JAY STRIPED 12.35	PTP

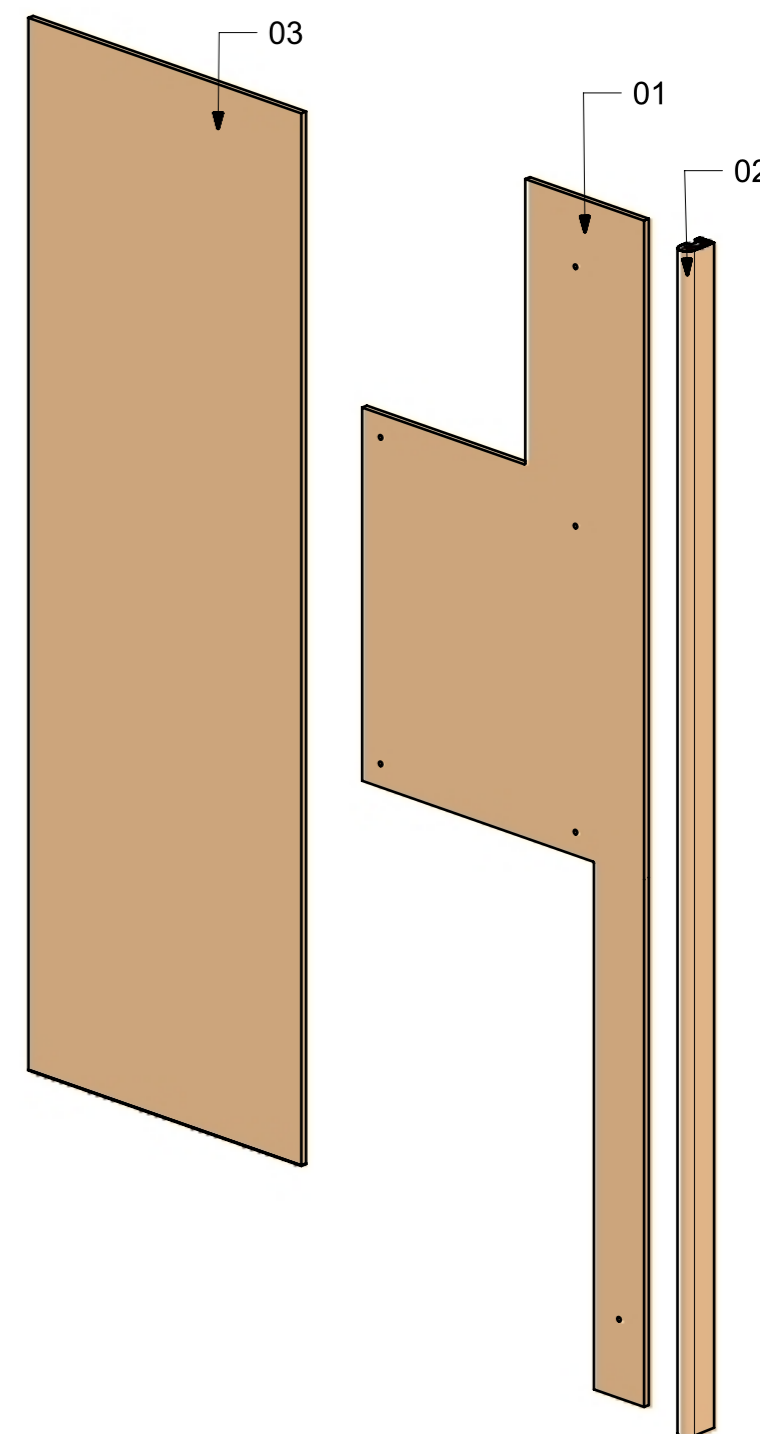
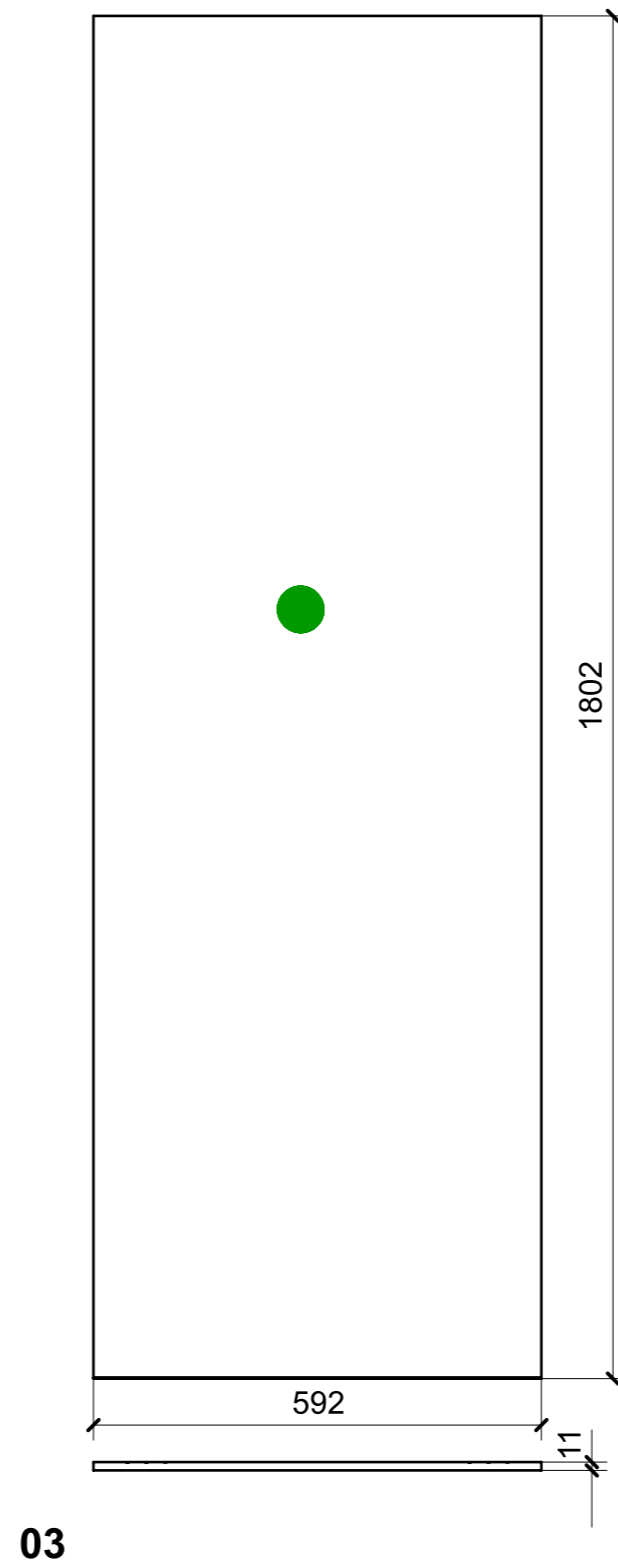
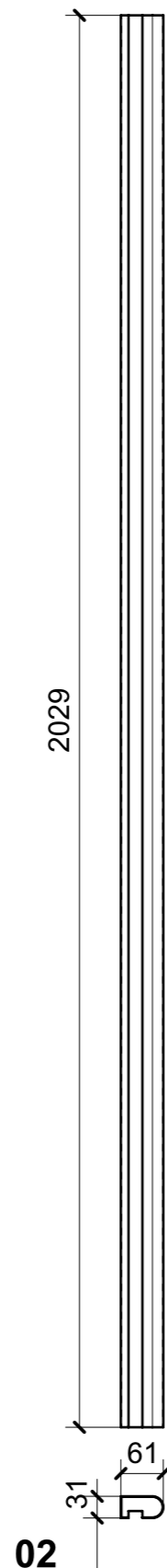
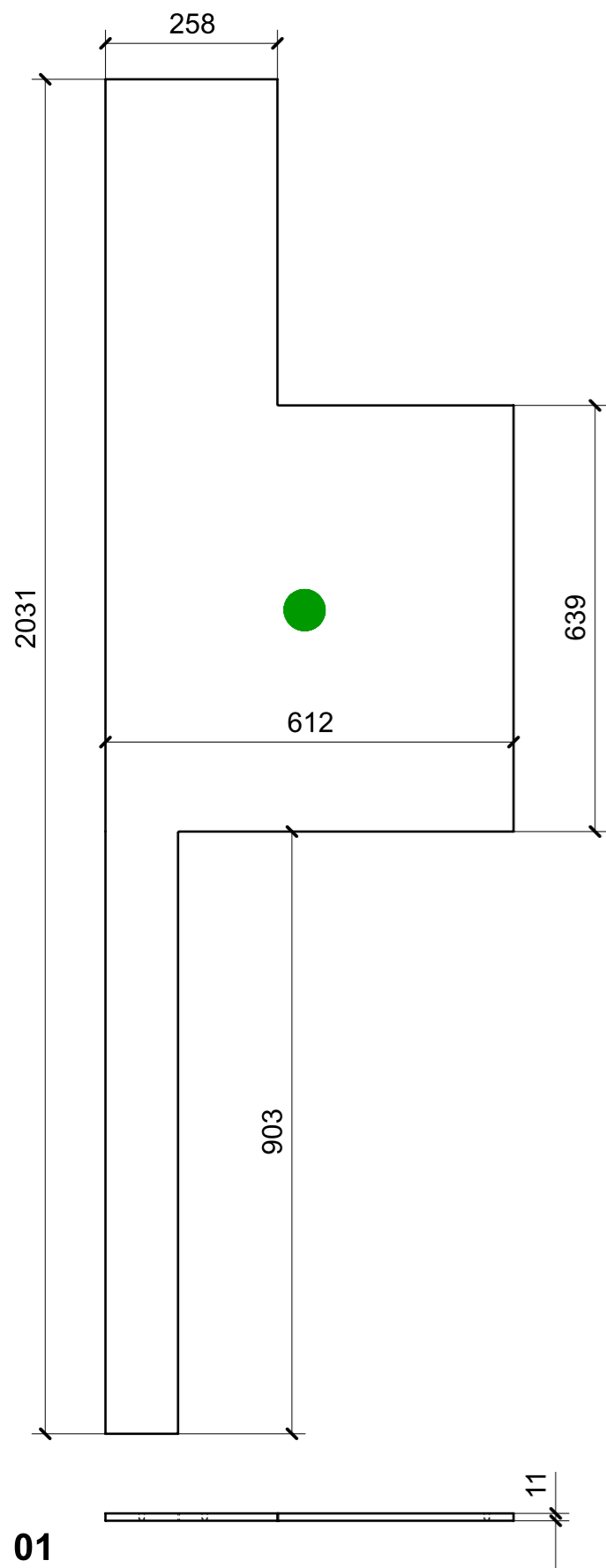

FERRAMENTA	QTY
FITLOCK M_MASCHERPA_3MM_6020202101	8

VERNICIATURA LASTRA/LACCATI:

● = VERNICIARE 1 LATO + FILI RASATI O BORDATI

NESSUN SIMBOLO = VERNICIARE 2 LATI + FILI RASATI O BORDATI

LOCALE	CODICE	DESCRIZIONE COMPONENTE	FINITURA	GR.
CUCINA	MD321_R01_KKN01	MURETTO CURVATO CHIUSURA STD.VAR.2	LAISTRA ALPI JAY STRIPED 12.35	PTP

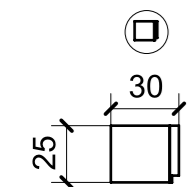
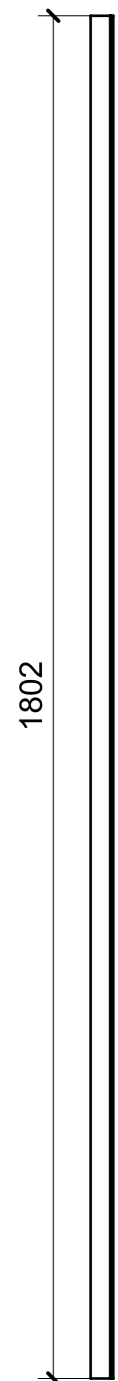

01

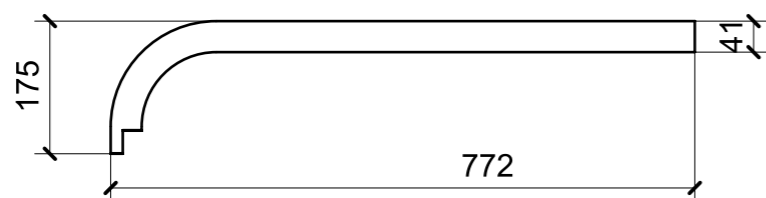
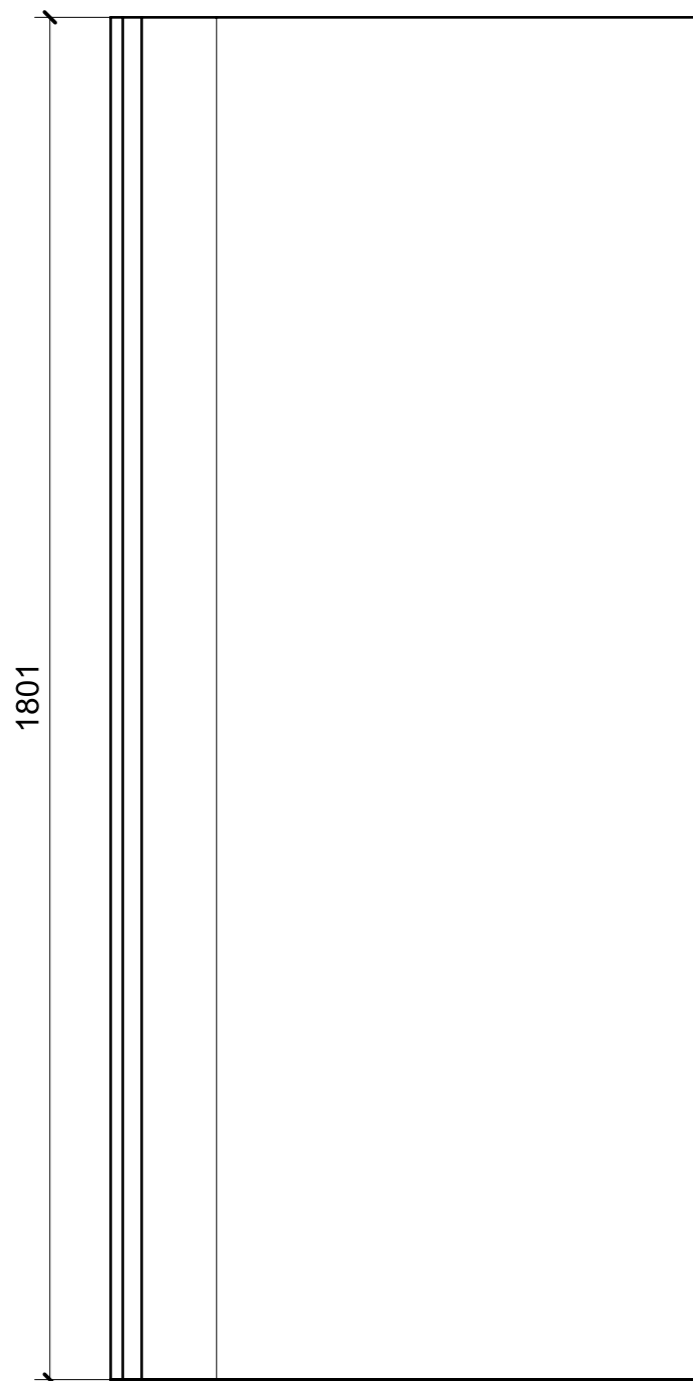

02



03

04

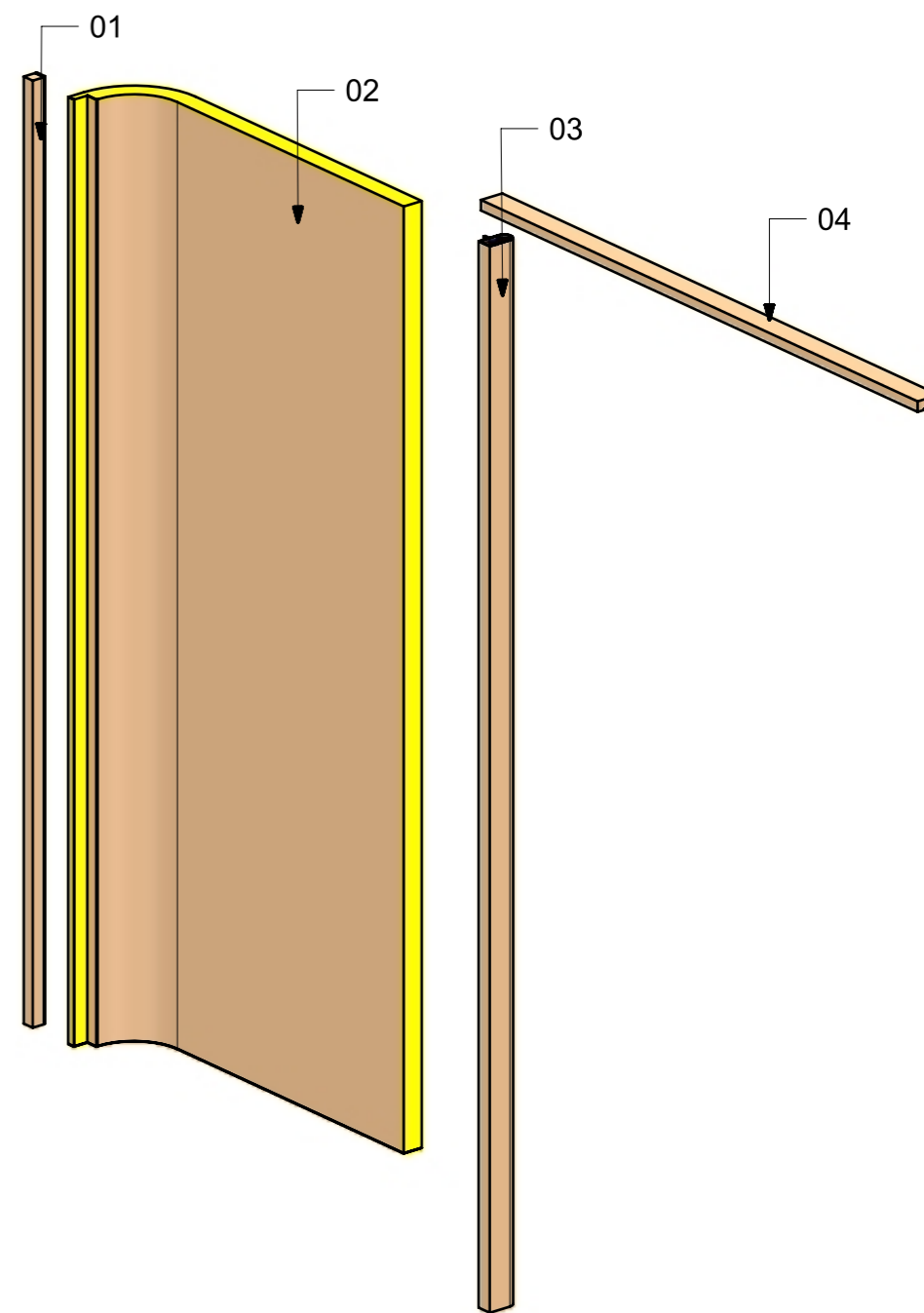
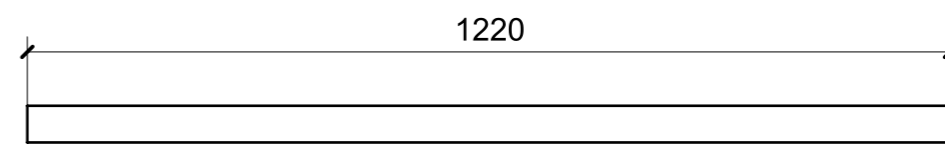

LAMELLO

VERNICIATURA LASTRA/LACCATI:

● = VERNICIARE 1 LATO + FILI RASATI O BORDATI

NESSUN SIMBOLO = VERNICIARE 2 LATI + FILI RASATI O BORDATI