

LOCALE	CODICE	DESCRIZIONE COMPONENTE	FINITURA	GR.
BAGNO OSPITI DX	MD320_L02_ZE01	CIELINO INGRESSO	LACCATO NCS- S - 1002-Y -MANOPESCA	4

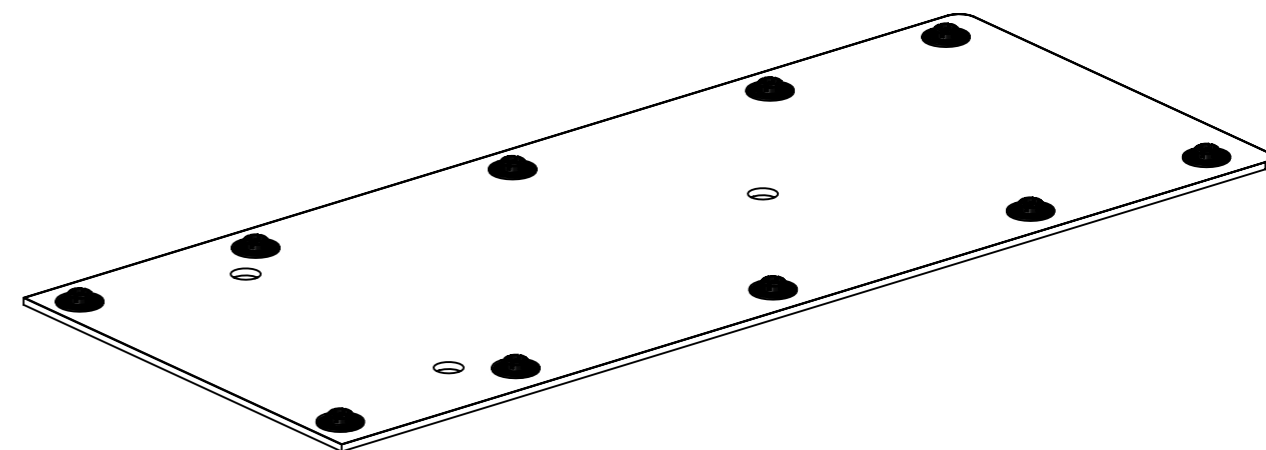

FERRAMENTA	QTY
FITLOCK M_MASCHERPA_3MM_6020202101	10

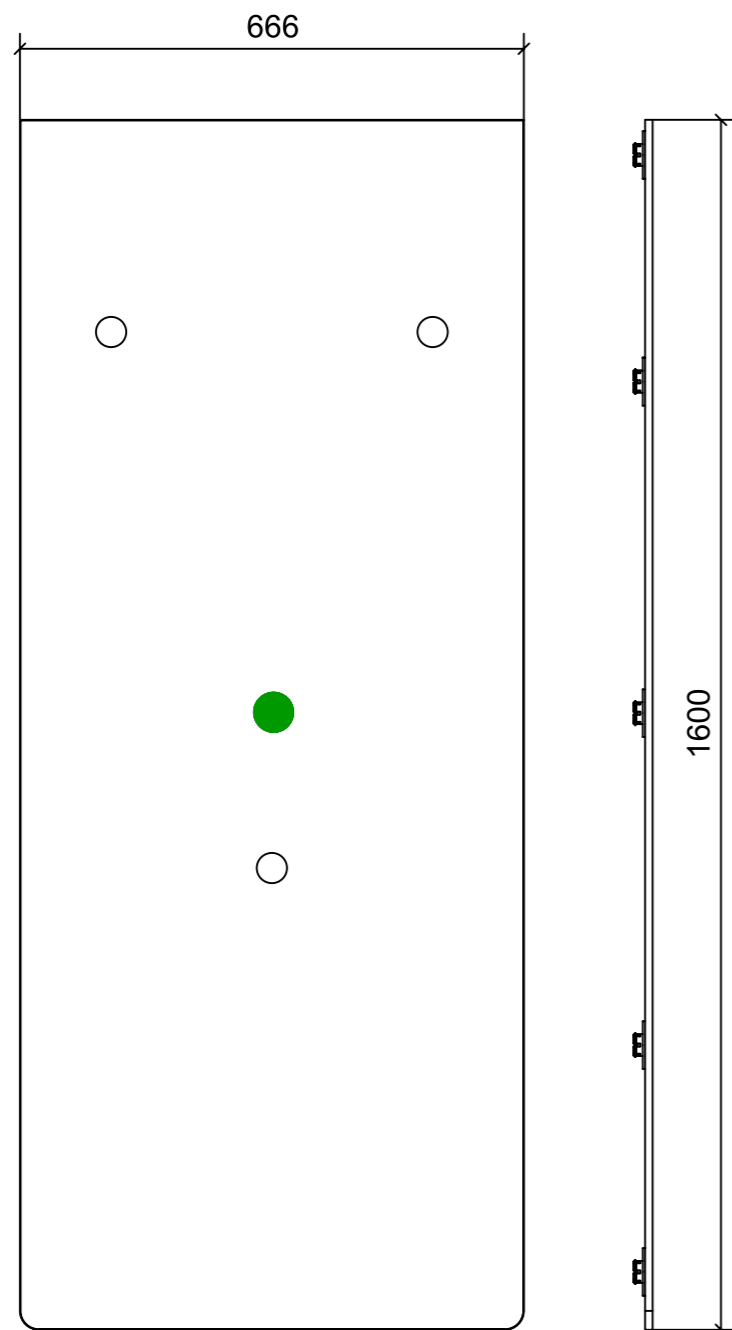
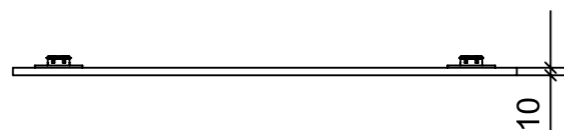

VERNICIATURA LASTRA/LACCATI:

● = FILI RASATI

● = VERNICIARE 1 LATO + FILI RASATI O BORDATI

NESSUN SIMBOLO = VERNICIARE 2 LATI + FILI RASATI O BORDATI

LOCALE	CODICE	DESCRIZIONE COMPONENTE	FINITURA	GR.
BAGNO OSPITI DX	MD320_L02_ZH01	RIVESTIMENTI ZONA DOCCIA	LACCATO NCS- S - 1002-Y -MANOPESCA	2

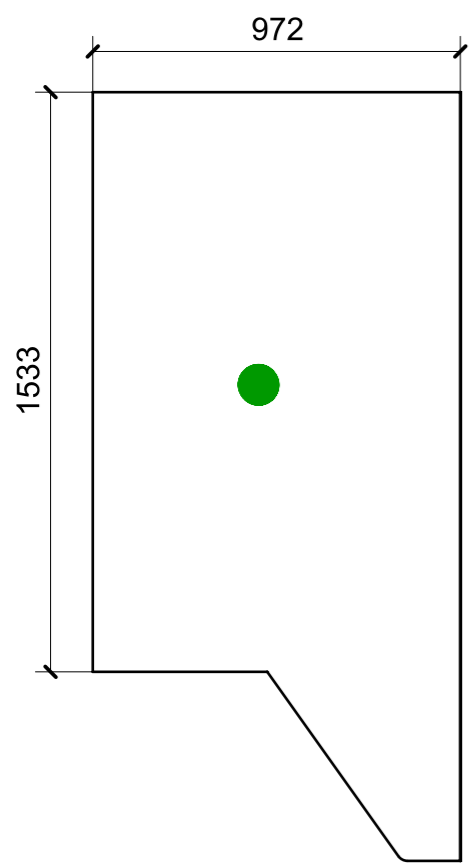

01

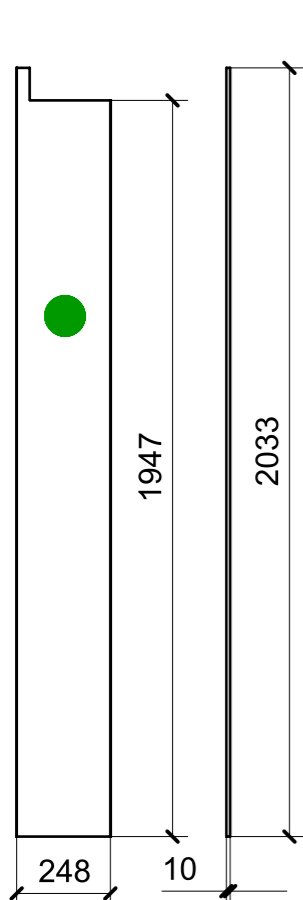
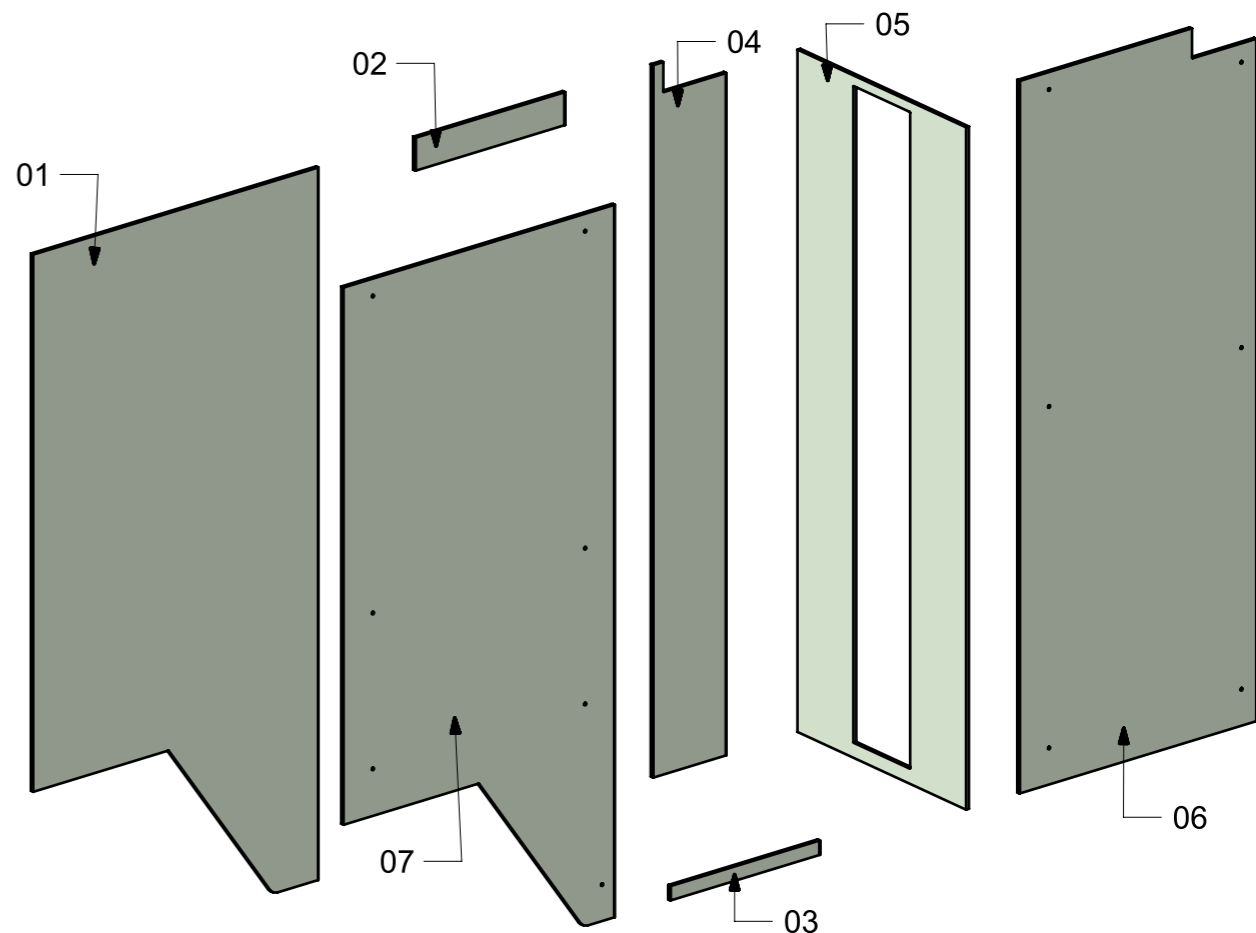
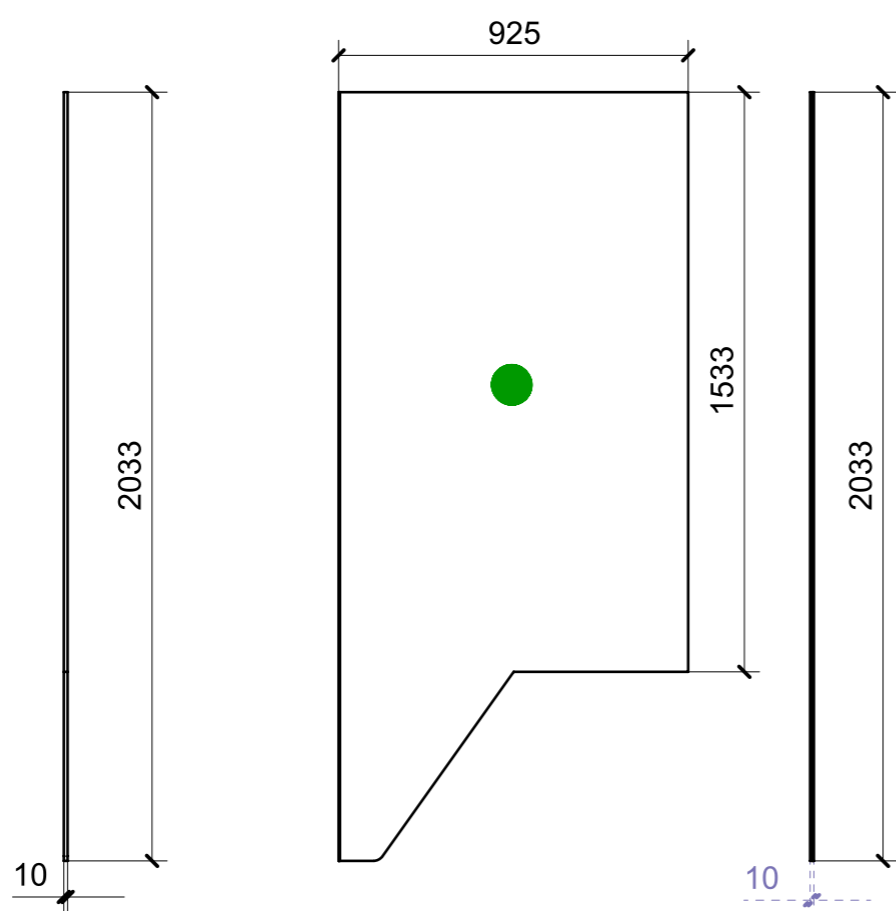

04

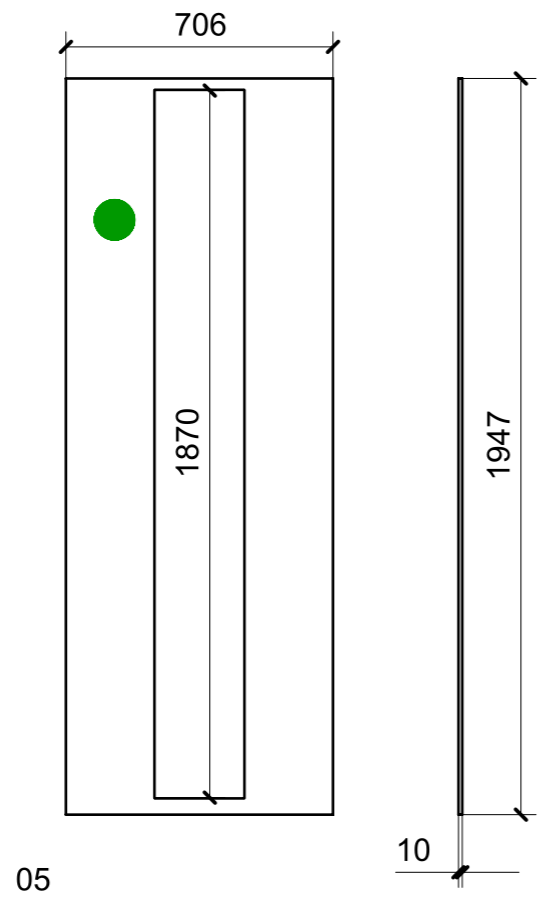

05

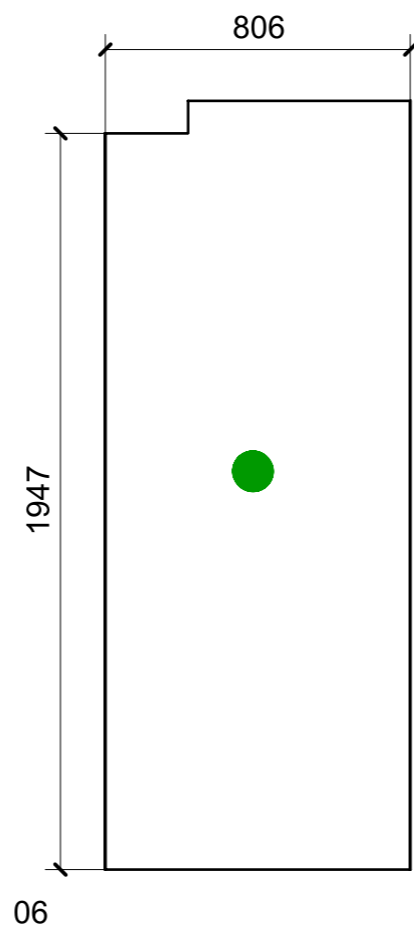

06

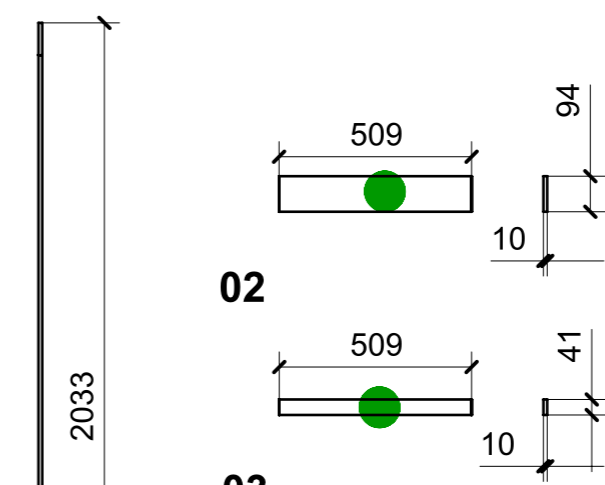

02

03

VERNICIATURA LASTRA/LACCATI:

● = FILI RASATI

● = VERNICIARE 1 LATO + FILI RASATI O BORDATI

NESSUN SIMBOLO = VERNICIARE 2 LATI + FILI RASATI O BORDATI

LOCALE	CODICE	DESCRIZIONE COMPONENTE	FINITURA	GR.
BAGNO OSPITI DX	MD320_L02_ZI01	STRUTTURA MURATA DOCCIA	LACCATO NCS- S - 1002-Y -MANOPESCA	2

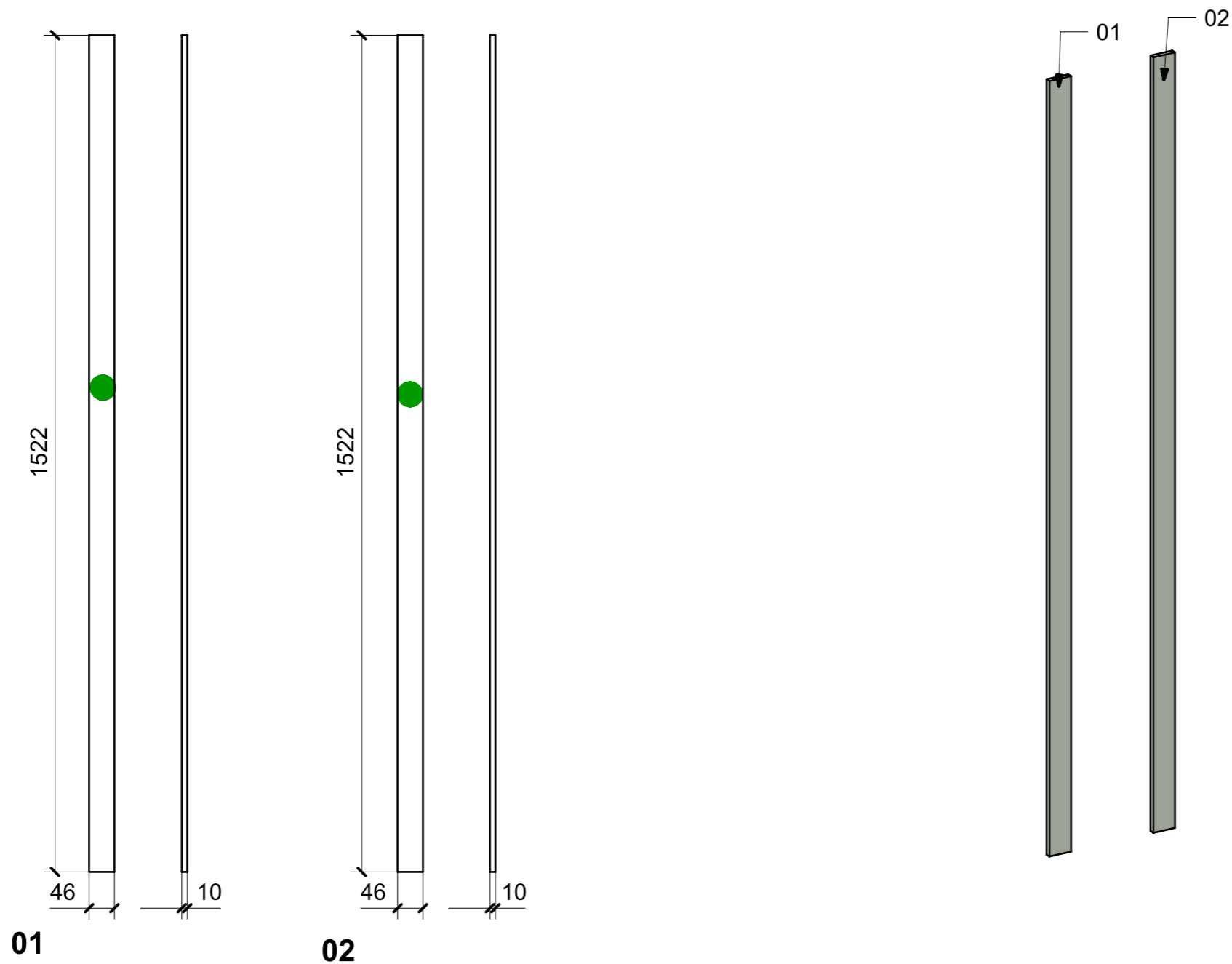

VERNICIATURA LASTRA/LACCATI:

● = FILI RASATI

● = VERNICIARE 1 LATO + FILI RASATI O BORDATI

NESSUN SIMBOLO = VERNICIARE 2 LATI + FILI RASATI O BORDATI

LOCALE	CODICE	DESCRIZIONE COMPONENTE	FINITURA	GR.
BAGNO OSPITI DX	MD320_L02_ZL01	RIV. SOTTO SEDUTA DOCCIA	LACCATO NCS- S - 1002-Y -MANOPESCA	2

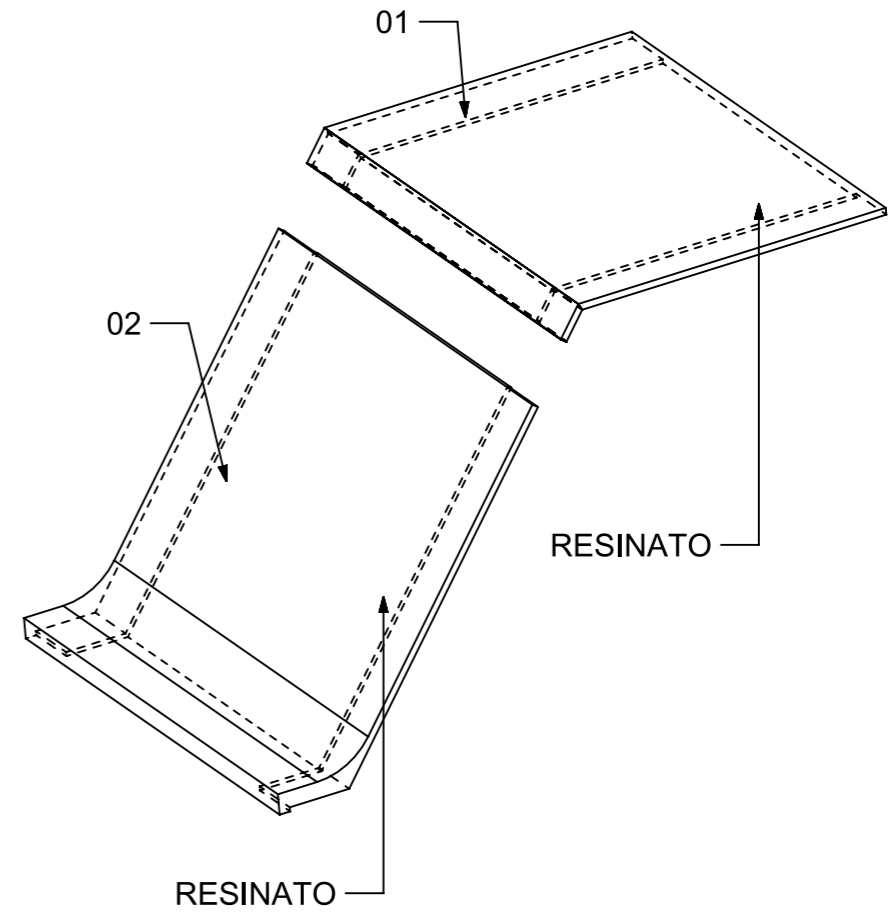
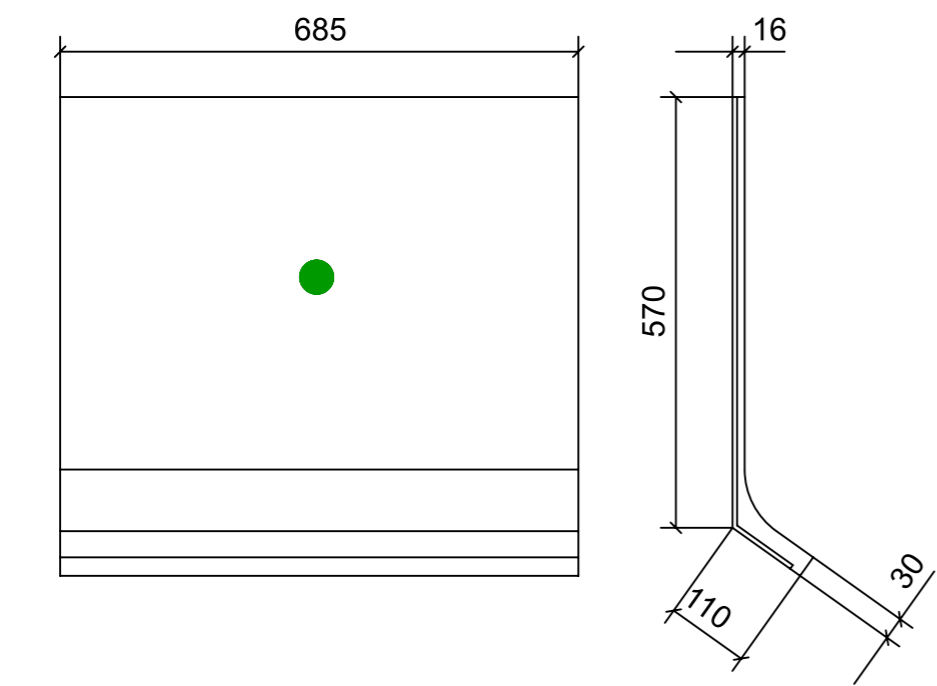
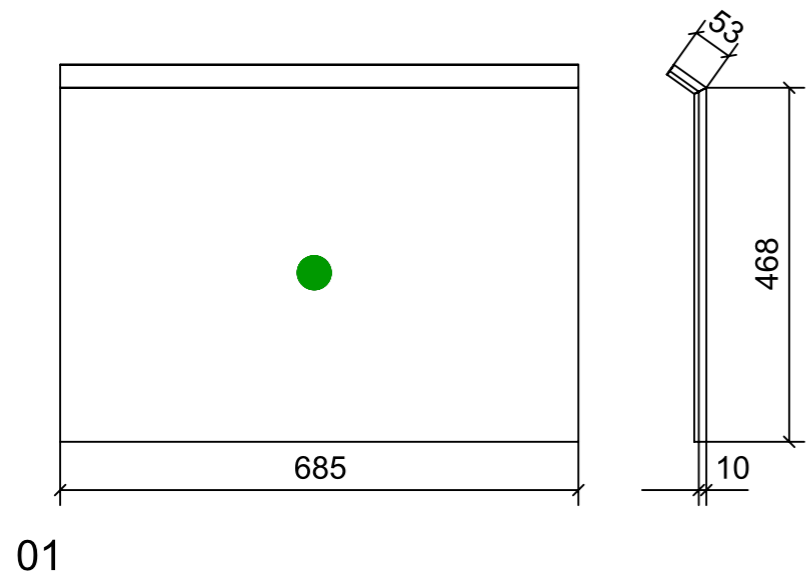

VERNICIATURA LASTRA/LACCATI:

● = FILI RASATI

● = VERNICIARE 1 LATO + FILI RASATI O BORDATI

NESSUN SIMBOLO = VERNICIARE 2 LATI + FILI RASATI O BORDATI

LOCALE	CODICE	DESCRIZIONE COMPONENTE	FINITURA	GR.
BAGNO OSPITI DX	MD320_L02_ZO01	CIELINO ZONA DOCCIA	LACCATO NCS- S - 1002-Y -MANOPESCA	4

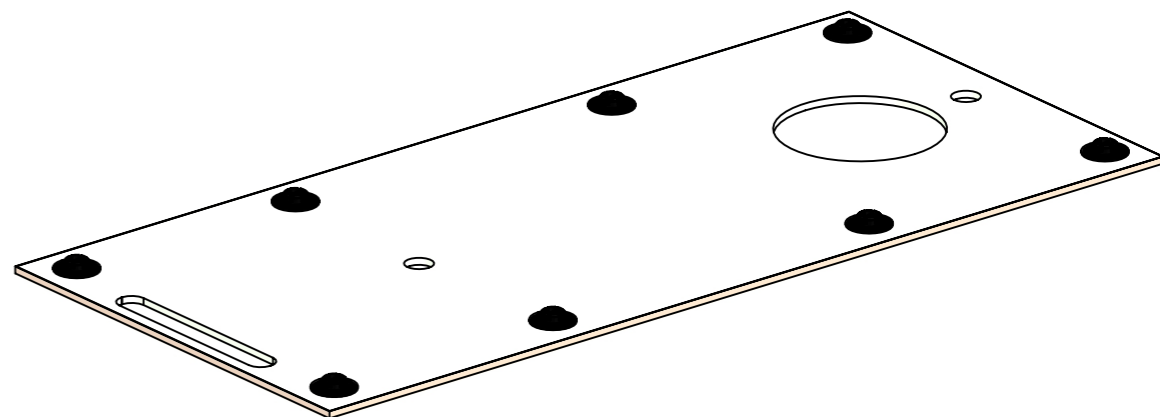
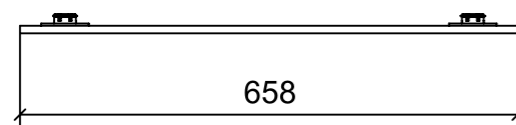
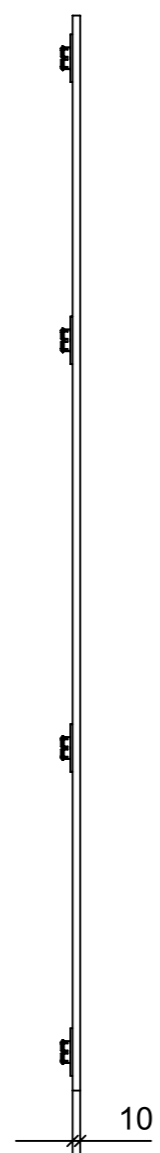
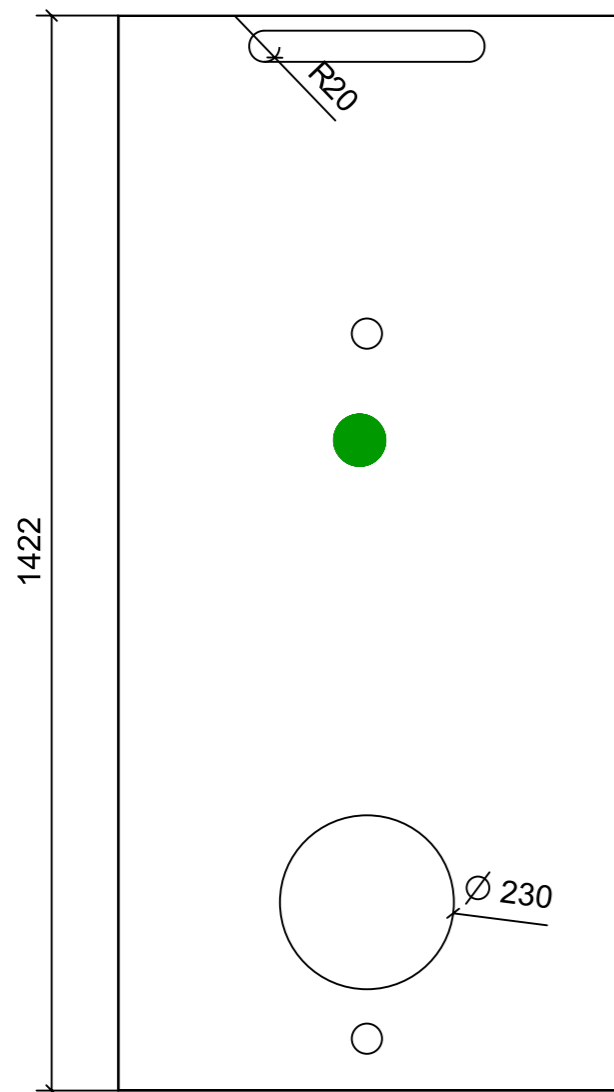

FERRAMENTA	QTY
FITLOCK M_MASCHERPA_3MM_6020202101	8

VERNICIATURA LASTRA/LACCATI:

● = FILI RASATI

● = VERNICIARE 1 LATO + FILI RASATI O BORDATI

NESSUN SIMBOLO = VERNICIARE 2 LATI + FILI RASATI O BORDATI

LOCALE	CODICE	DESCRIZIONE COMPONENTE	FINITURA	GR.
BAGNO OSPITI DX	MD320_L02_ZP01	CIELINO SOTTO SCALA	LACCATO NCS- S - 1002-Y -MANOPESCA	PTP

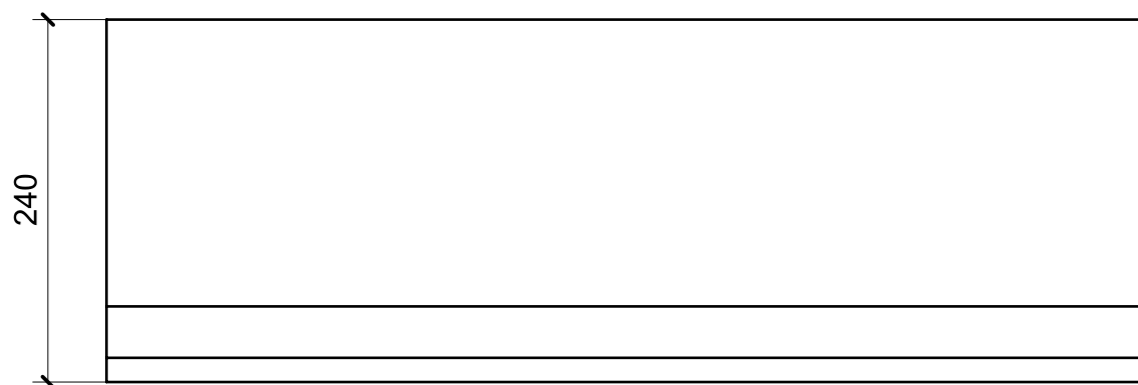
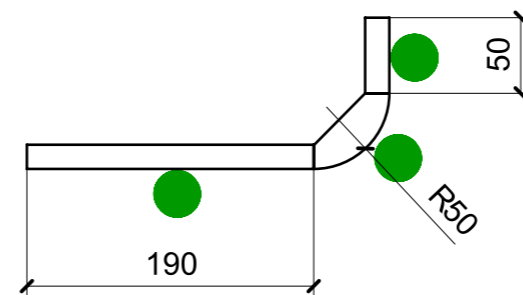
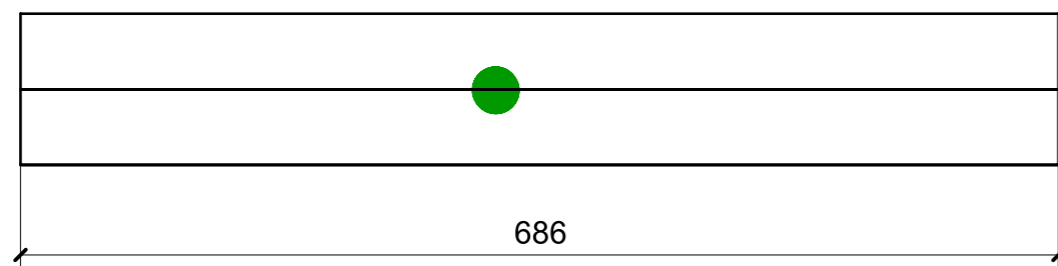
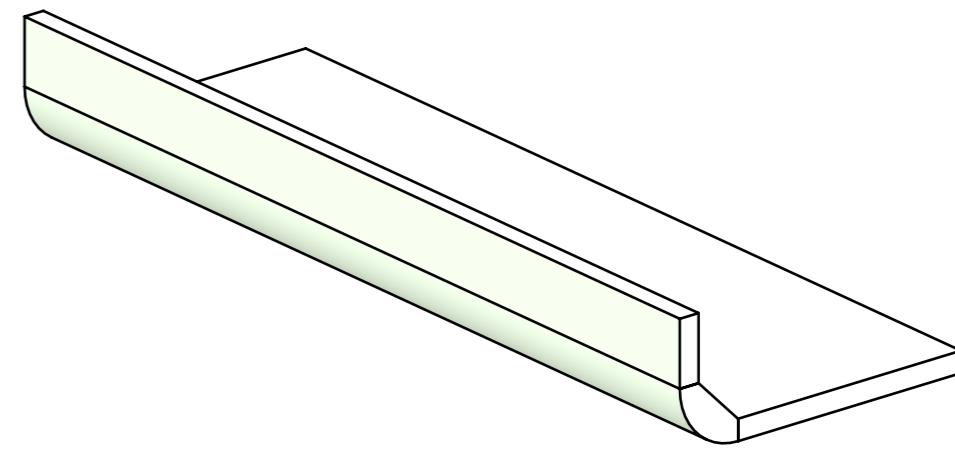

VERNICIATURA LASTRA/LACCATI:

● = FILI RASATI

● = VERNICIARE 1 LATO + FILI RASATI O BORDATI

NESSUN SIMBOLO = VERNICIARE 2 LATI + FILI RASATI O BORDATI