

LOCALE	CODICE	DESCRIZIONE COMPONENTE	FINITURA	GR.
CABINA VIP	MD320_L01_VB01	COMODINO PRUA	LACCATO BRONZO SPAZZOLATO	4

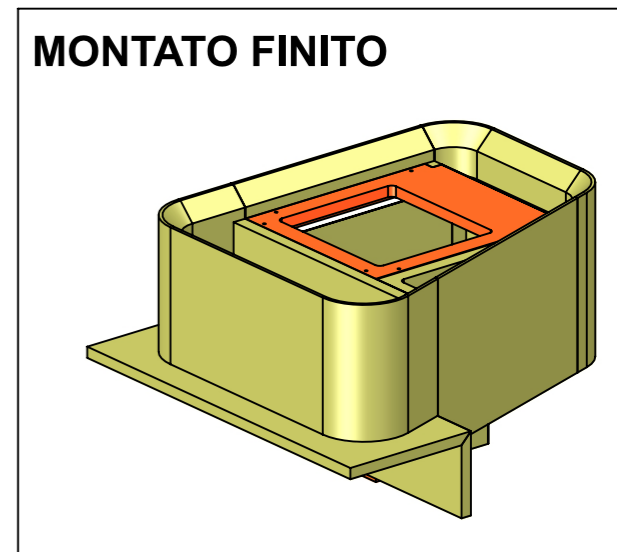
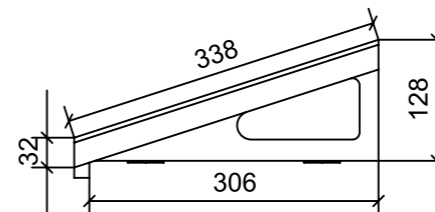
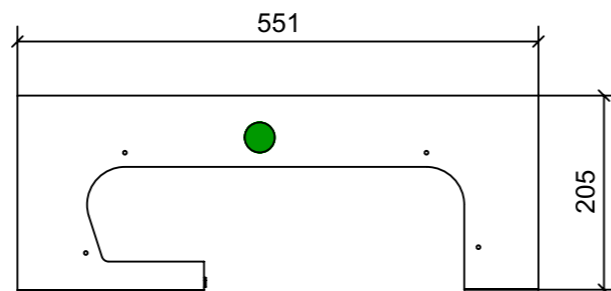
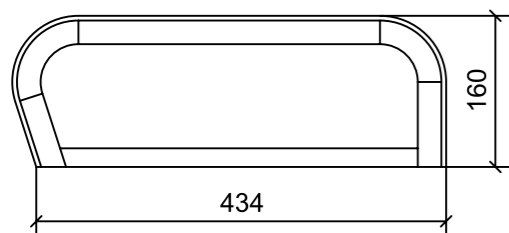
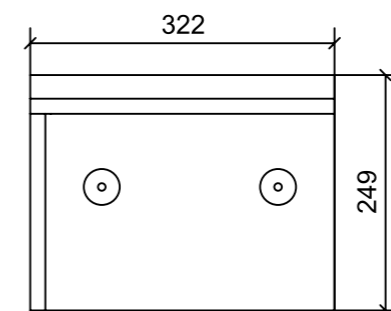
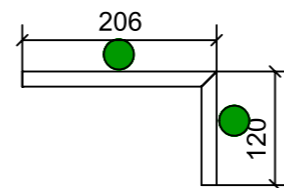
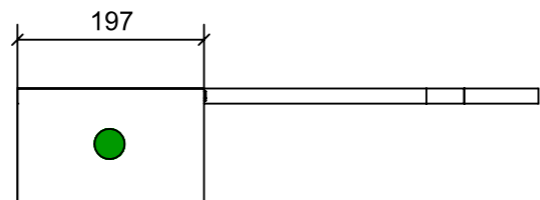
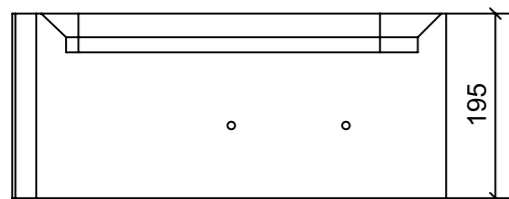

01

02

05

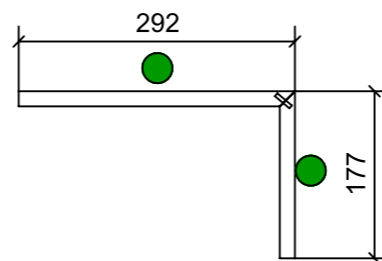
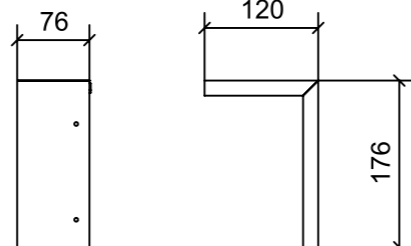
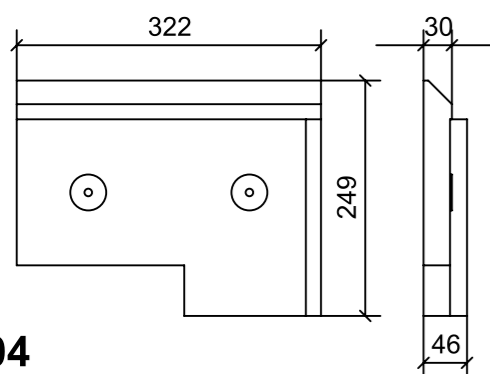

04

03

06

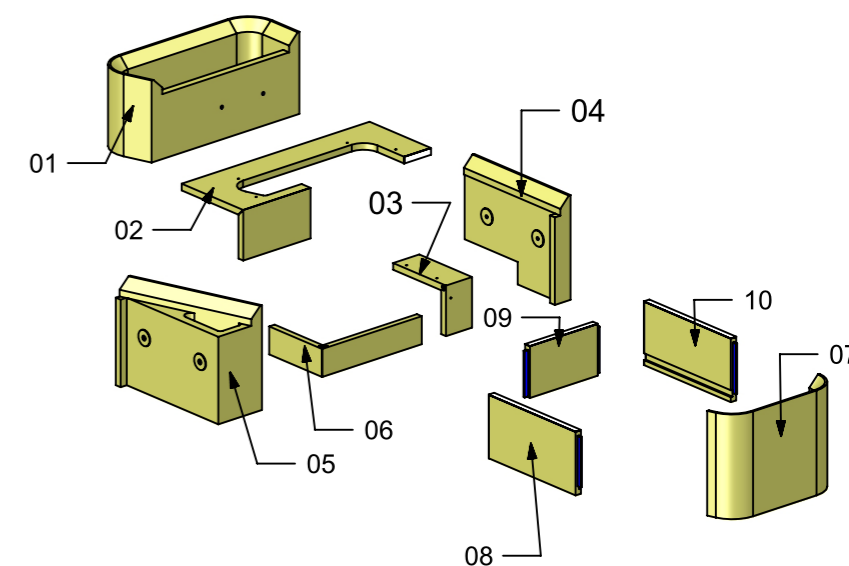
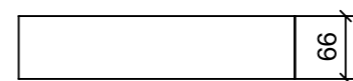

08

09

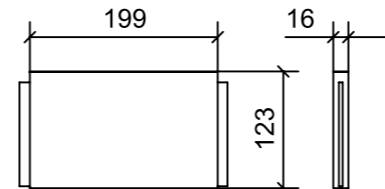
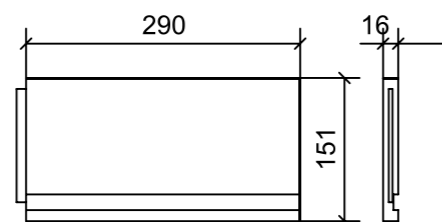
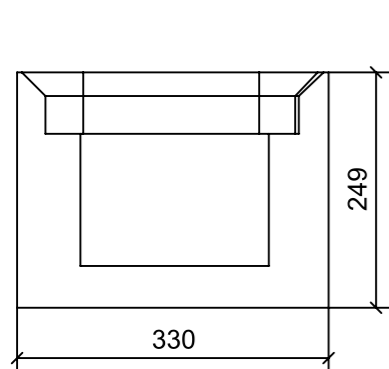

07

10

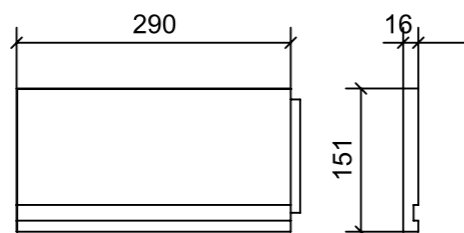
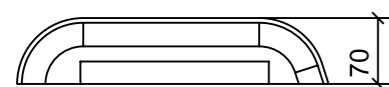

FERRAMENTA	QTY
BUSSOLA 6MA X 10 FORO DIAM.8	4

VERNICIATURA LASTRA/LACCATI:



= VERNICIARE 1 LATO + FILI RASATI O BORDATI

NESSUN SIMBOLO = VERNICIARE 2 LATI + FILI RASATI O BORDATI

LOCALE	CODICE	DESCRIZIONE COMPONENTE	FINITURA	GR.
CABINA VIP	MD320_L01_VC01	STRUTTURA LETTO	LACCATO BRONZO SPAZZOLATO	4

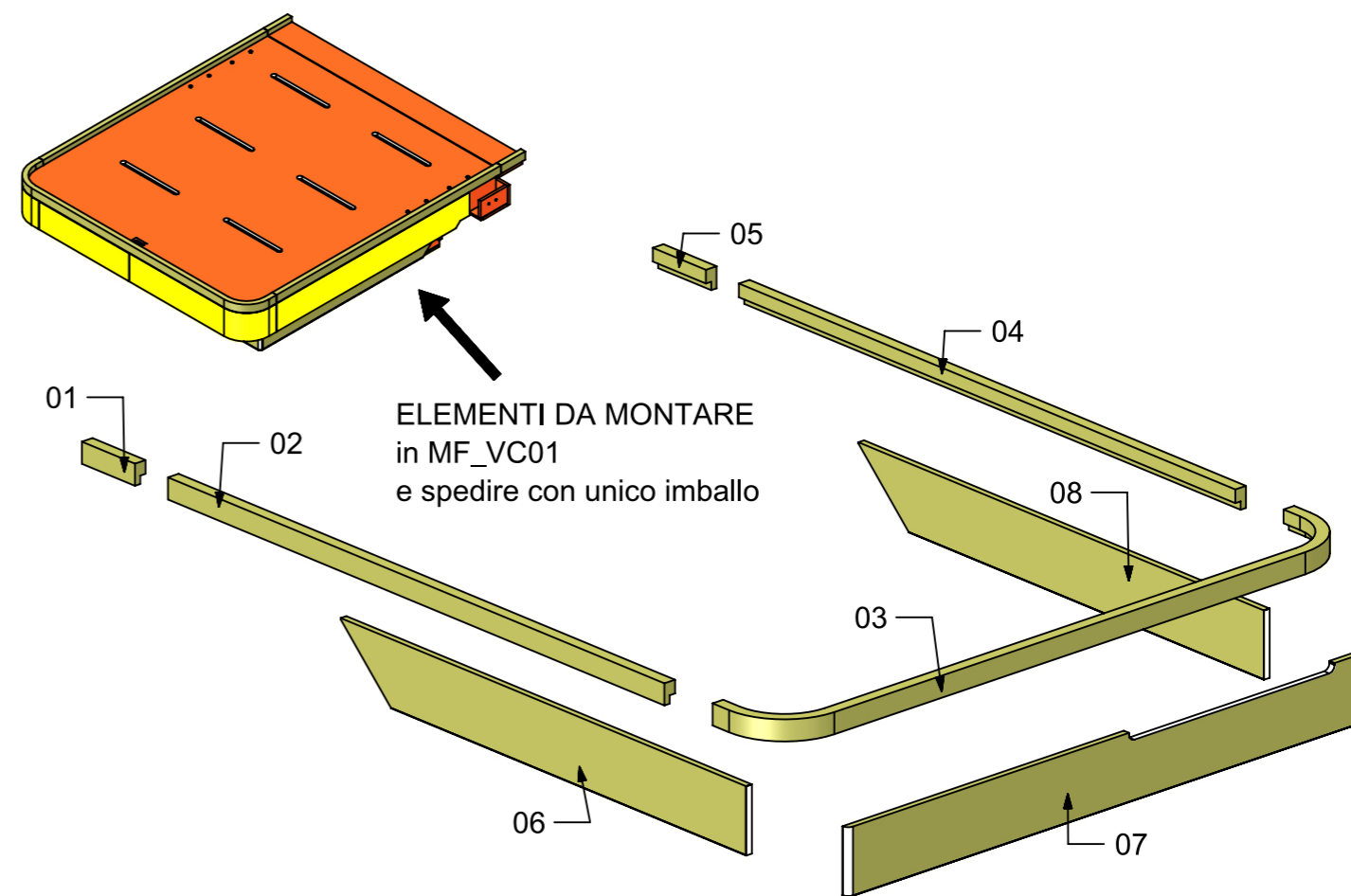
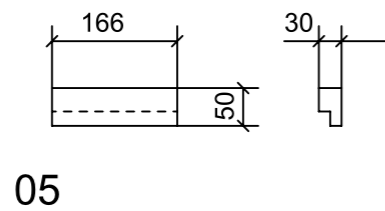
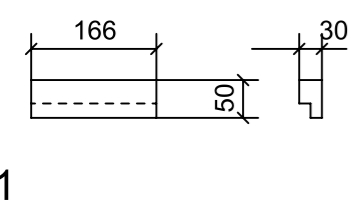
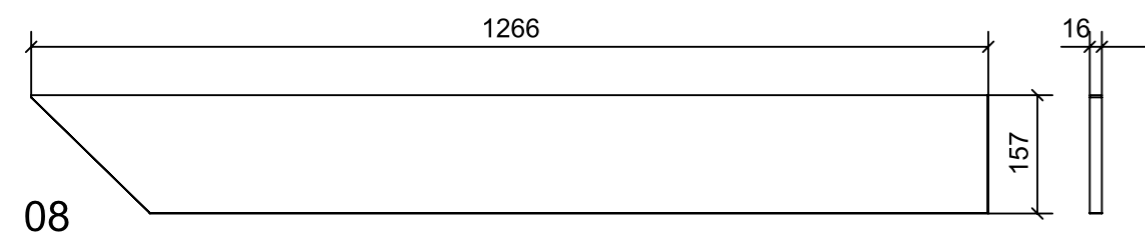
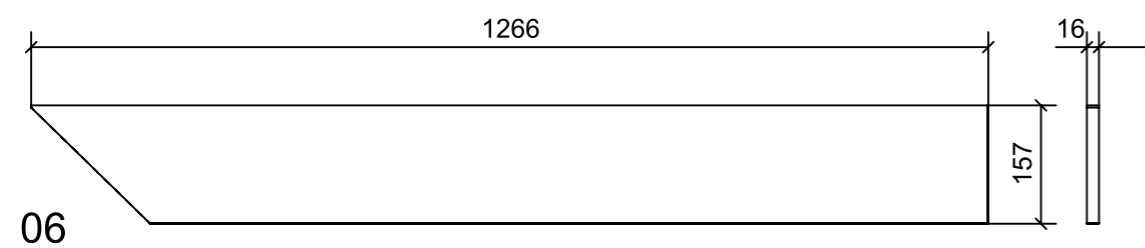
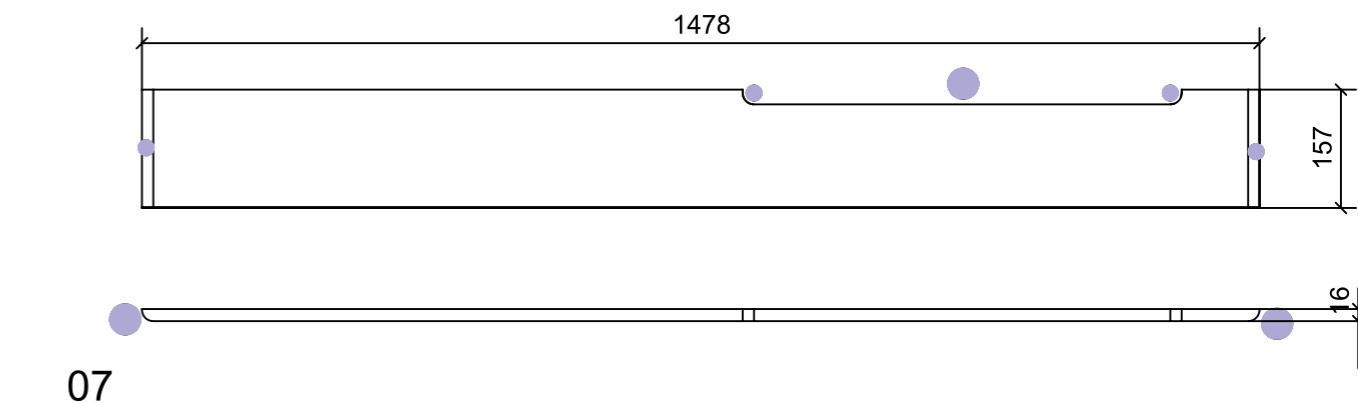
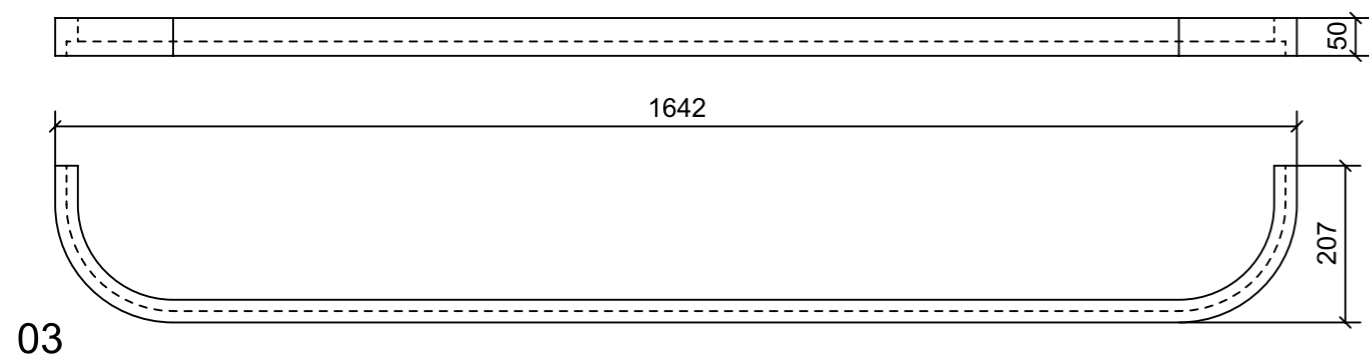
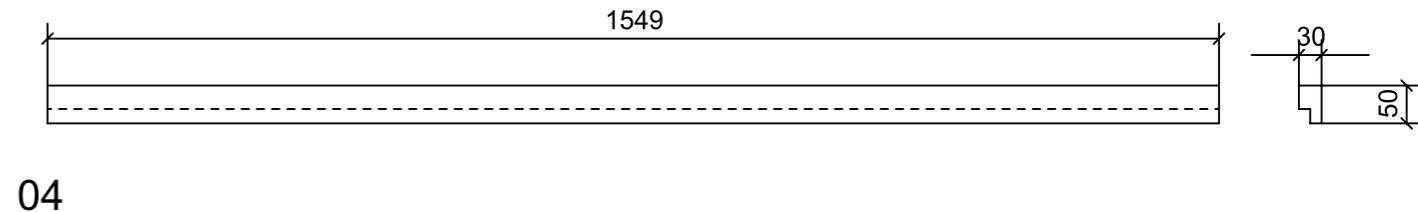
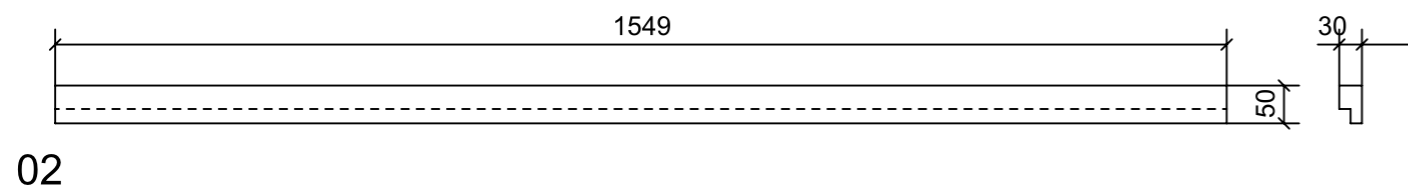

VERNICIATURA LASTRA/LACCATI:

● = FILI RASATI

● = VERNICIARE 1 LATO + FILI RASATI O BORDATI

NESSUN SIMBOLO = VERNICIARE 2 LATI + FILI RASATI O BORDATI

LOCALE	CODICE	DESCRIZIONE COMPONENTE	FINITURA	GR.
CABINA VIP	MD320_L01_VD01	COMODINO POPPA	LACCATO BRONZO SPAZZOLATO	4

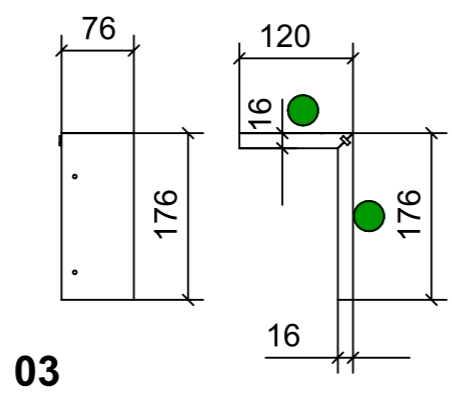
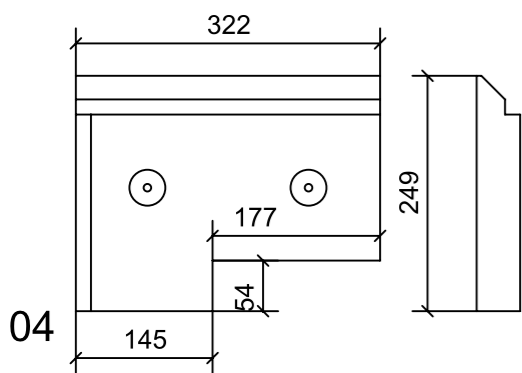
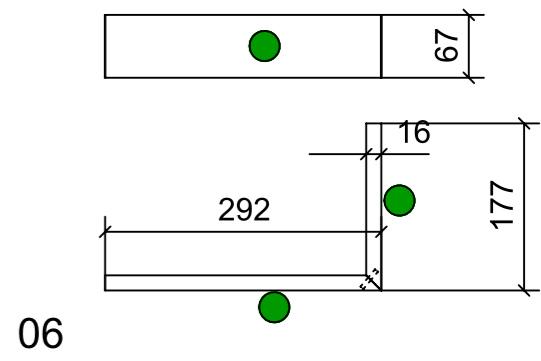
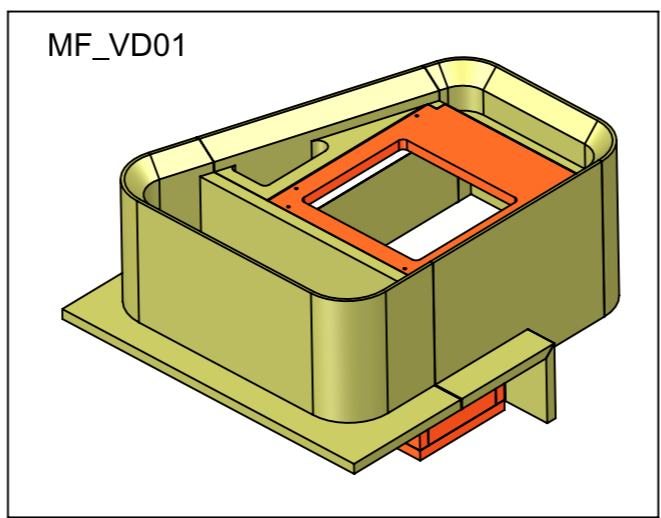
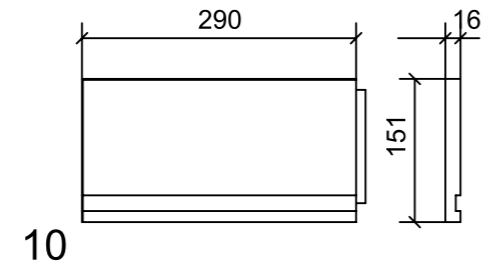
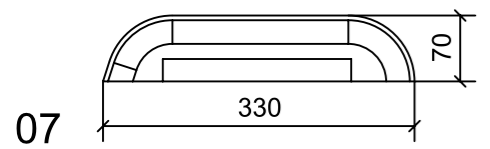
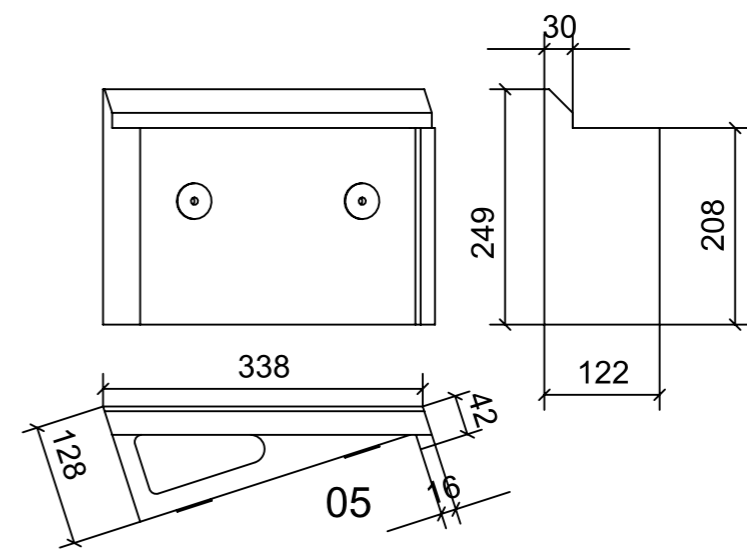
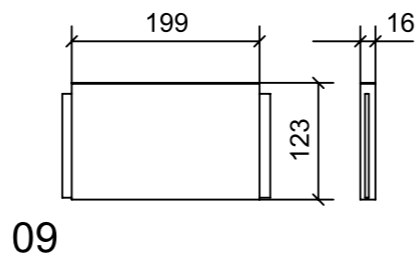
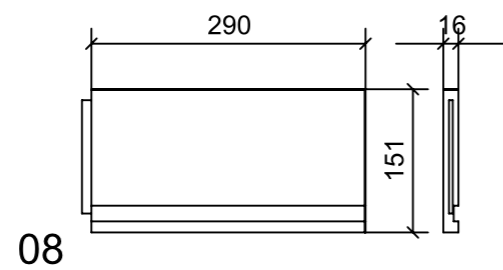
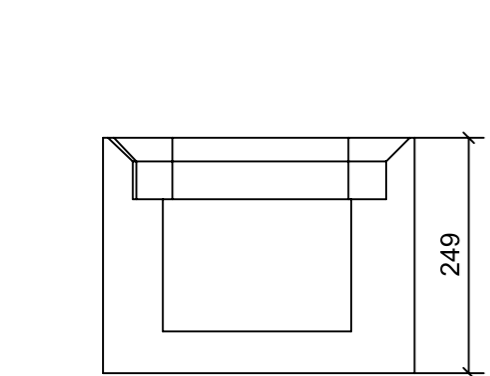

VERNICIATURA LASTRA/LACCATI:
 ● = VERNICIARE 1 LATO + FILI RASATI O BORDATI
 NESSUN SIMBOLO = VERNICIARE 2 LATI + FILI RASATI O BORDATI

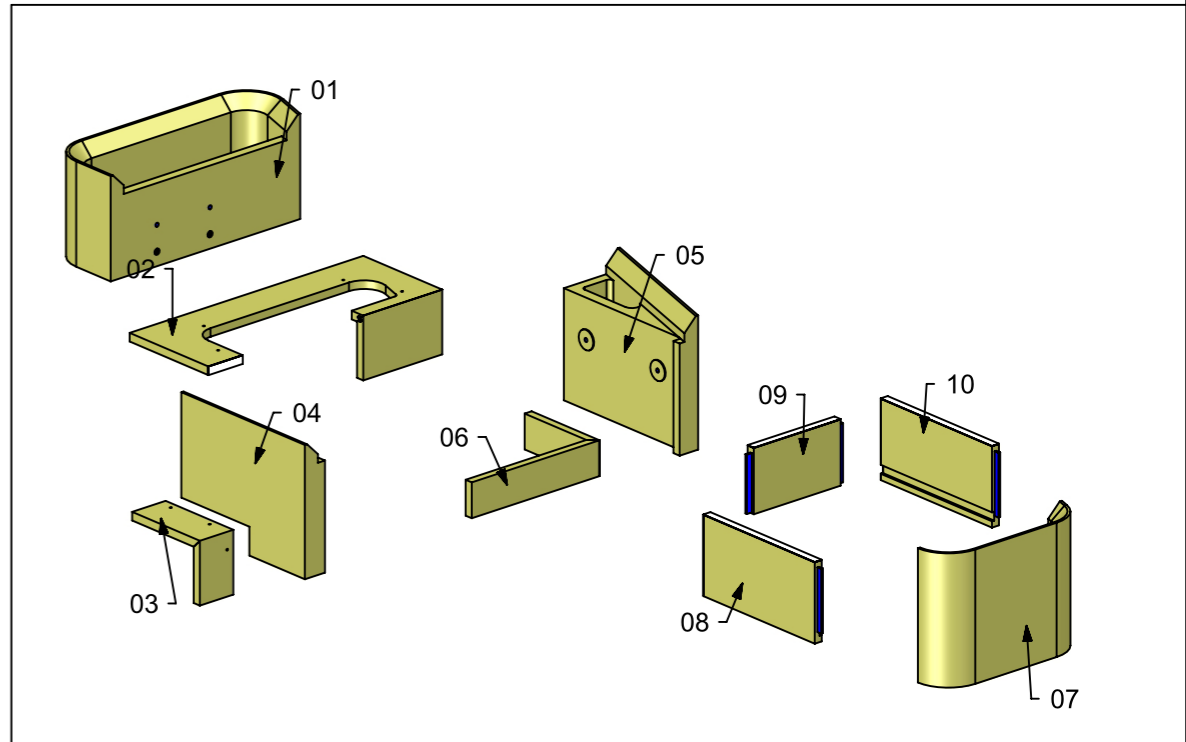
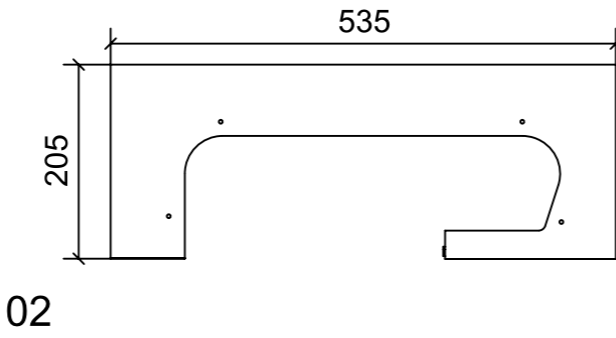
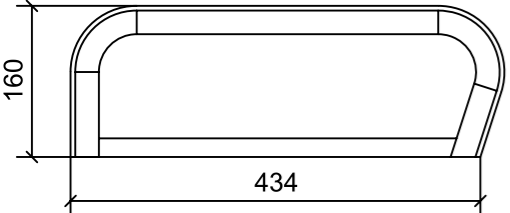
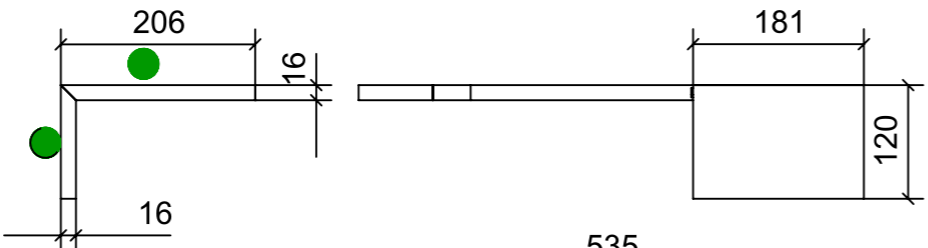
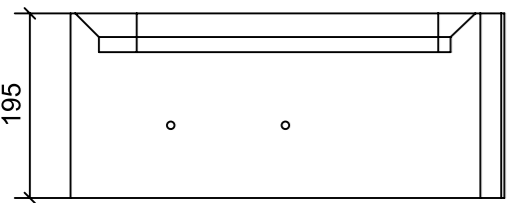

FERRAMENTA	QTY
BUSSOLA 6MA X 10 FORO DIAM.8	6

LOCALE	CODICE	DESCRIZIONE COMPONENTE	FINITURA	GR.
CABINA VIP	MD320_L01_VH01	CORNICE TV	LACCATO BRONZO SPAZZOLATO	4

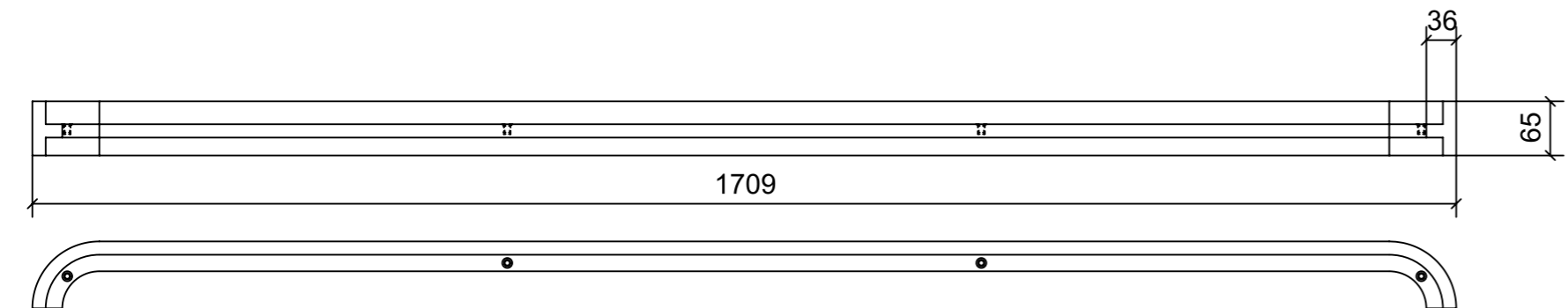

01

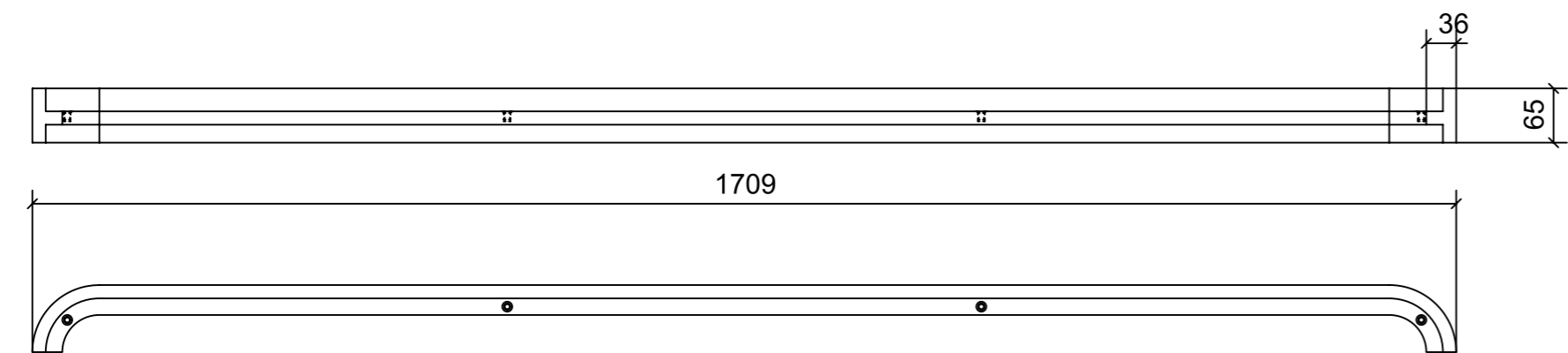

03

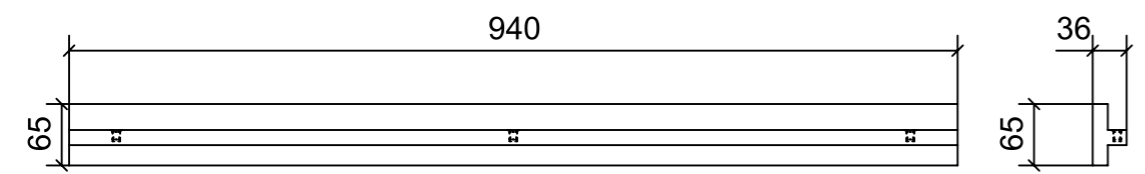

02

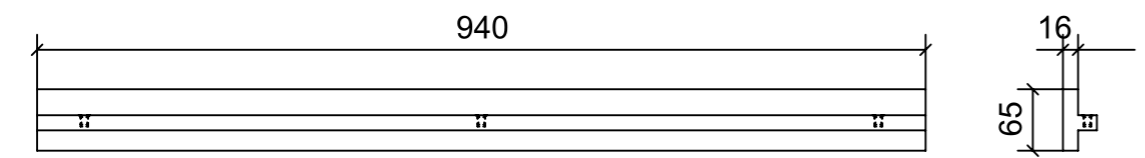

04

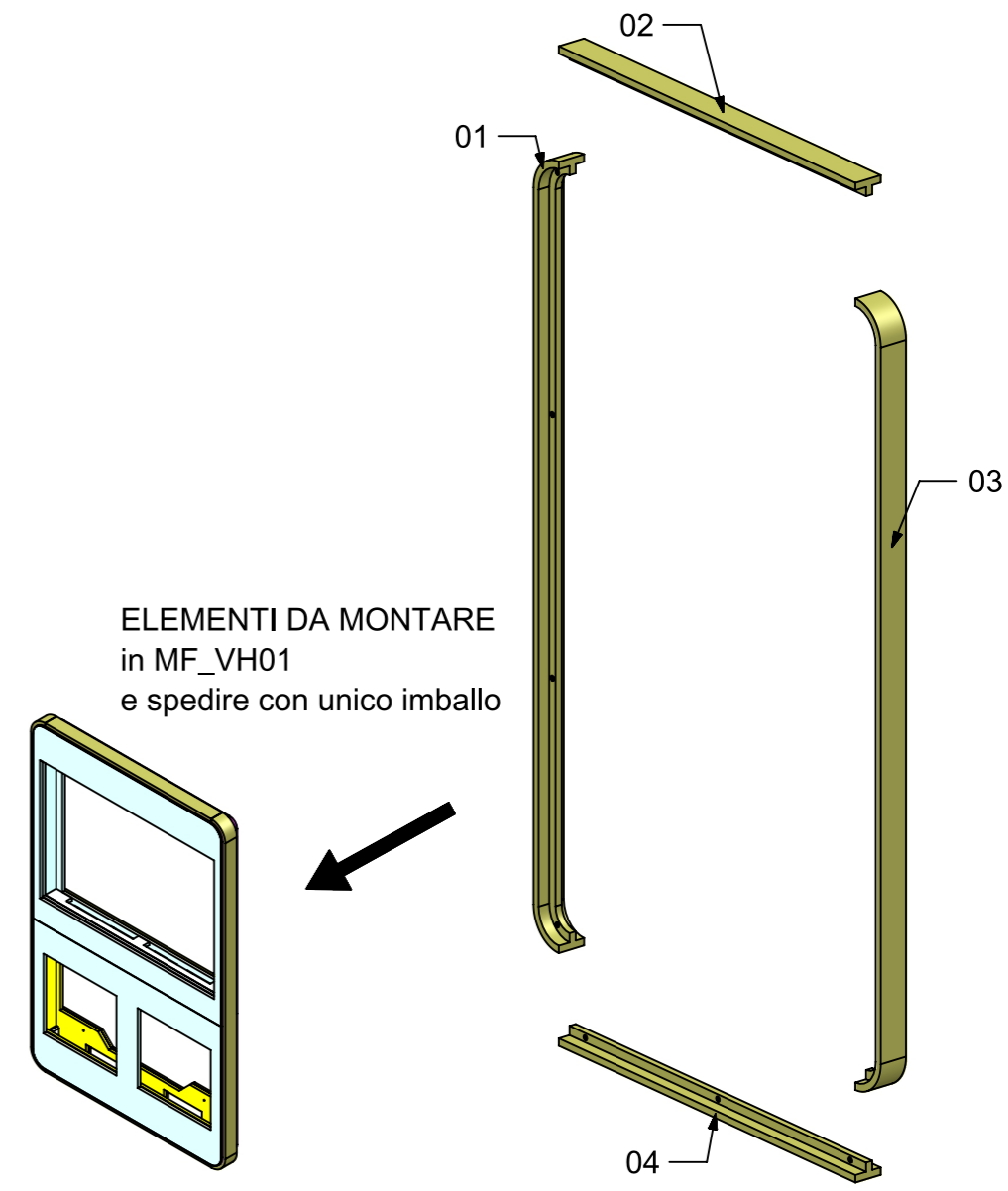

ELEMENTI DA MONTARE
in MF_VH01
e spedire con unico imballo

FERRAMENTA	QTY
BUSSOLA 6MA X 10 FORO DIAM.8	14

VERNICIATURA LASTRA/LACCATI:
● = VERNICIARE 1 LATO + FILI RASATI O BORDATI NESSUN SIMBOLO = VERNICIARE 2 LATI + FILI RASATI O BORDATI