

LOCALE	CODICE	DESCRIZIONE COMPONENTE	FINITURA	GR.
SALONE	MD320_MG_SA01	STRUTTURA MURATA DX PRUA		2

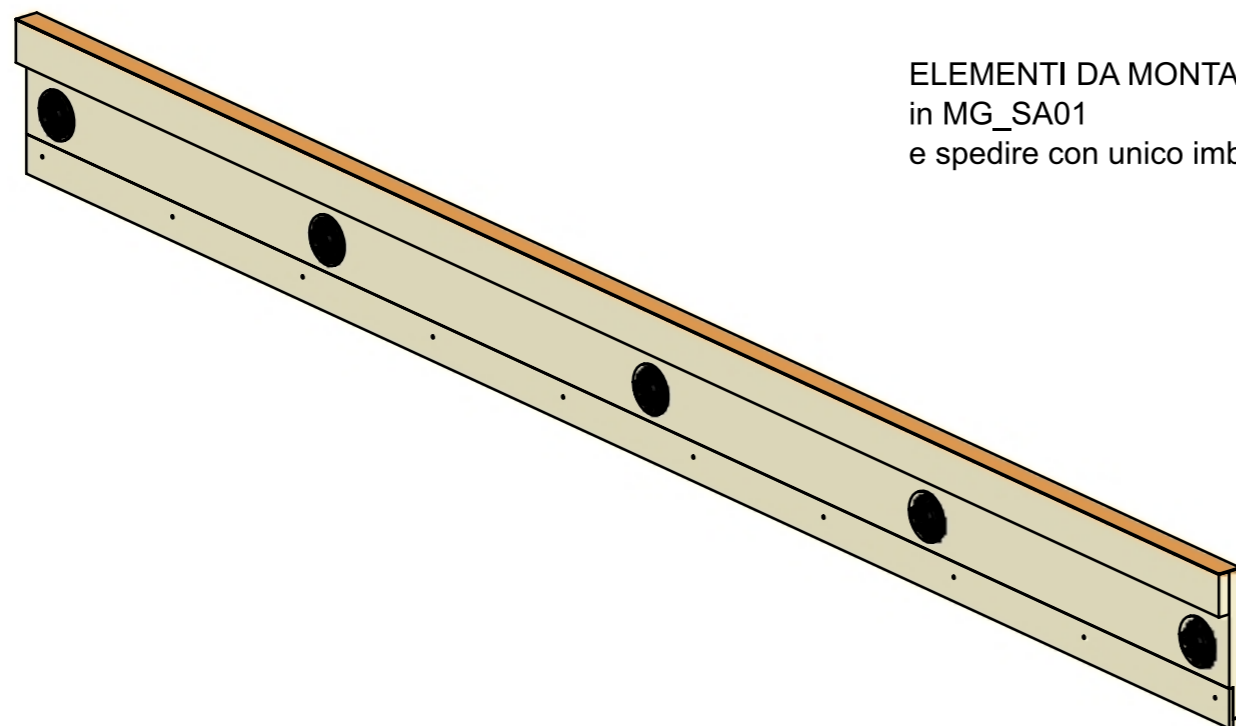

ELEMENTI DA MONTARE  
in MG\_SA01  
e spedire con unico imballo

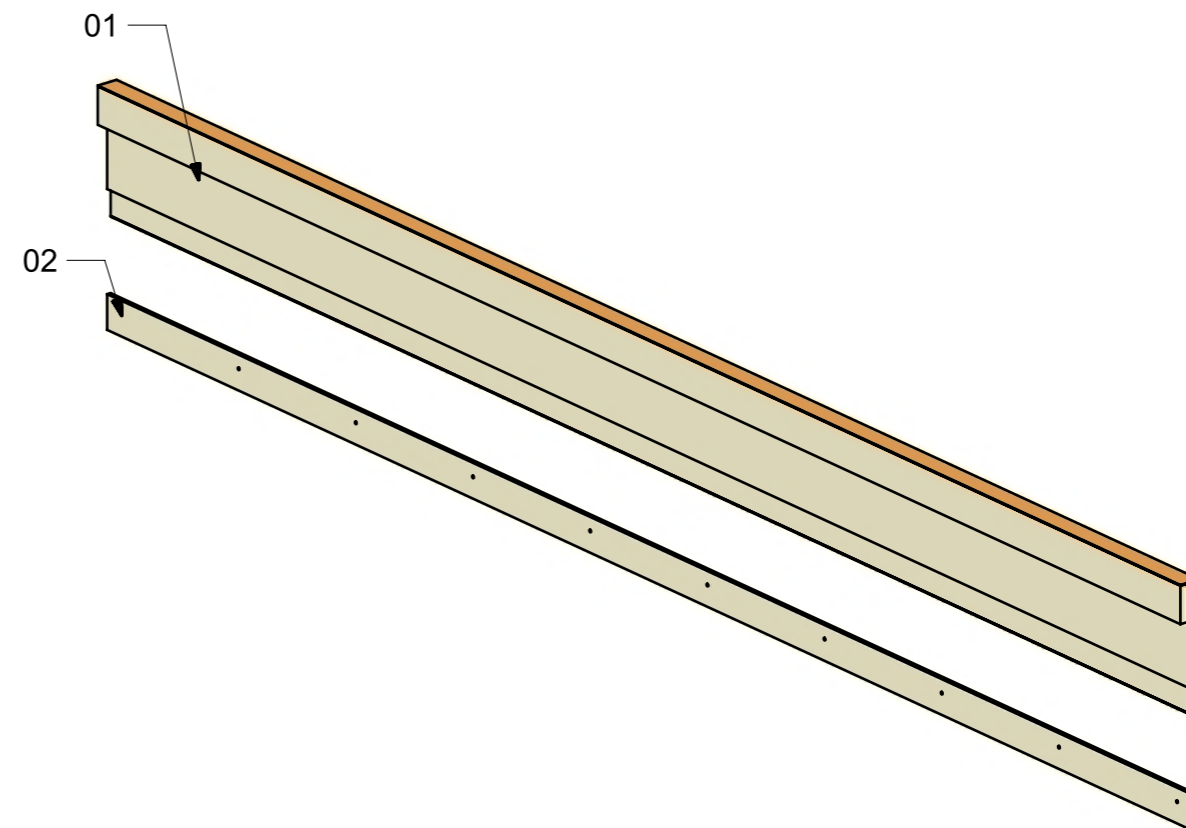

FERRAMENTA	QTY
FITLOCK M_MASCHERPA_3MM_6020202101	5

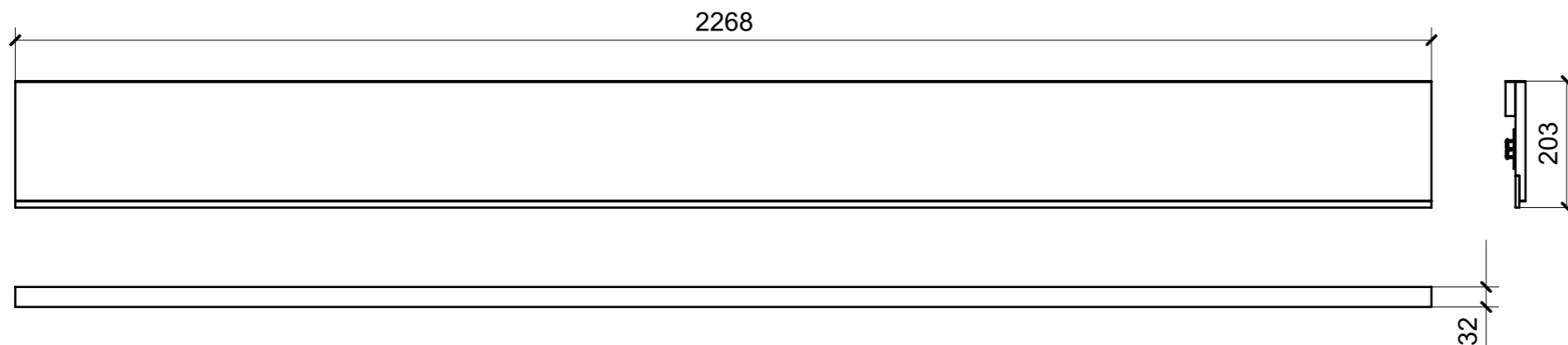

LOCALE	CODICE	DESCRIZIONE COMPONENTE	FINITURA	GR.
SALONE	MD320_MG_SB01	PLENUM MURATA DX PRUA		PTP

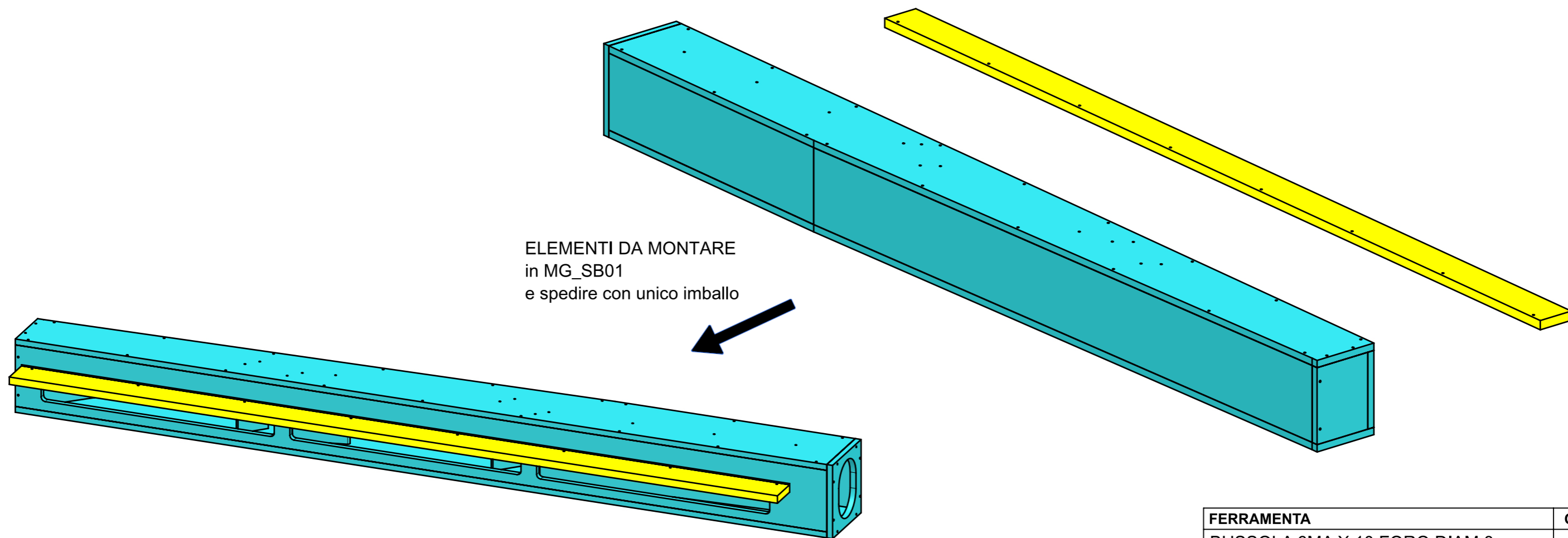

FERRAMENTA	QTY
BUSSOLA 6MA X 10 FORO DIAM.8	4

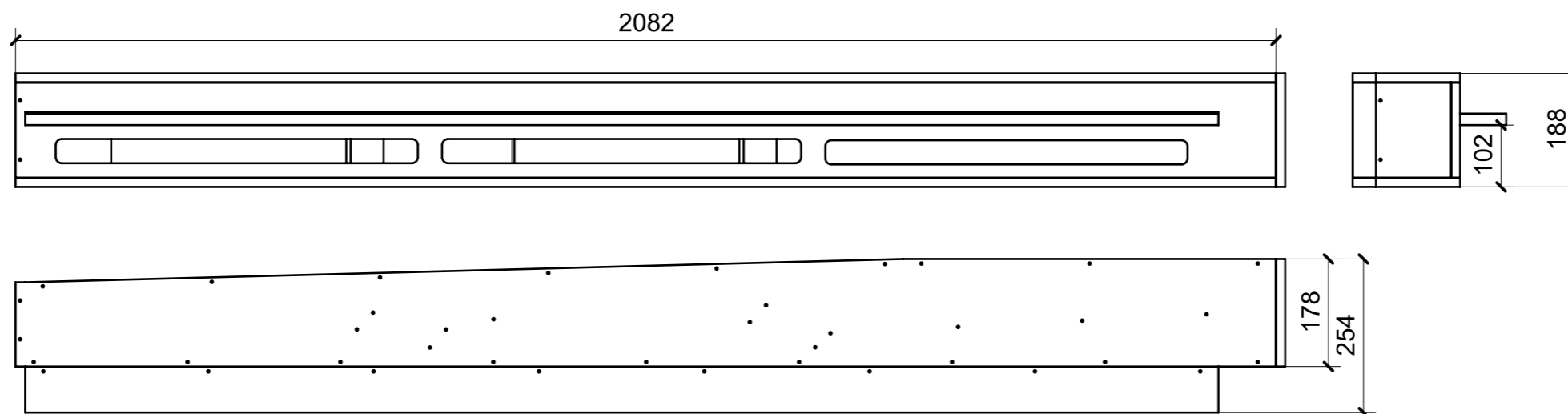

VERNICIATURA LASTRA/LACCATI:

● = FILI RASATI

● = VERNICIARE 1 LATO + FILI RASATI O BORDATI

NESSUN SIMBOLO = VERNICIARE 2 LATI + FILI RASATI O BORDATI

LOCALE	CODICE	DESCRIZIONE COMPONENTE	FINITURA	GR.
SALONE	MD320_MG_SC01	STRUTTURA MONTANTE DX		PTP

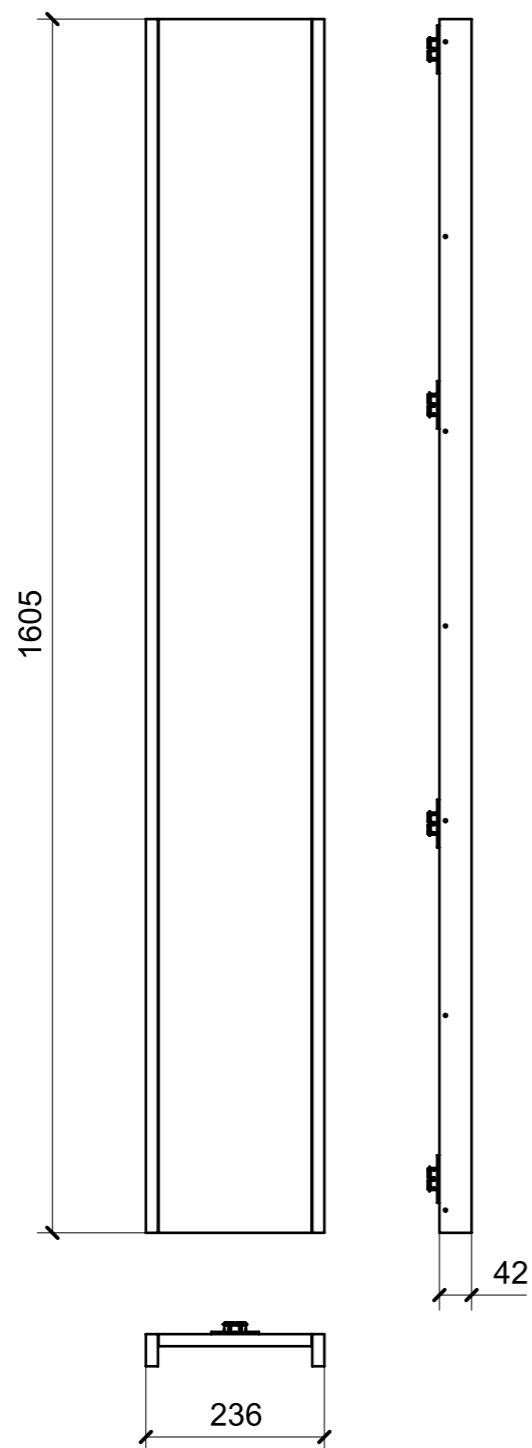

ELEMENTI DA MONTARE  
in MG\_SC01  
e spedire con unico imballo

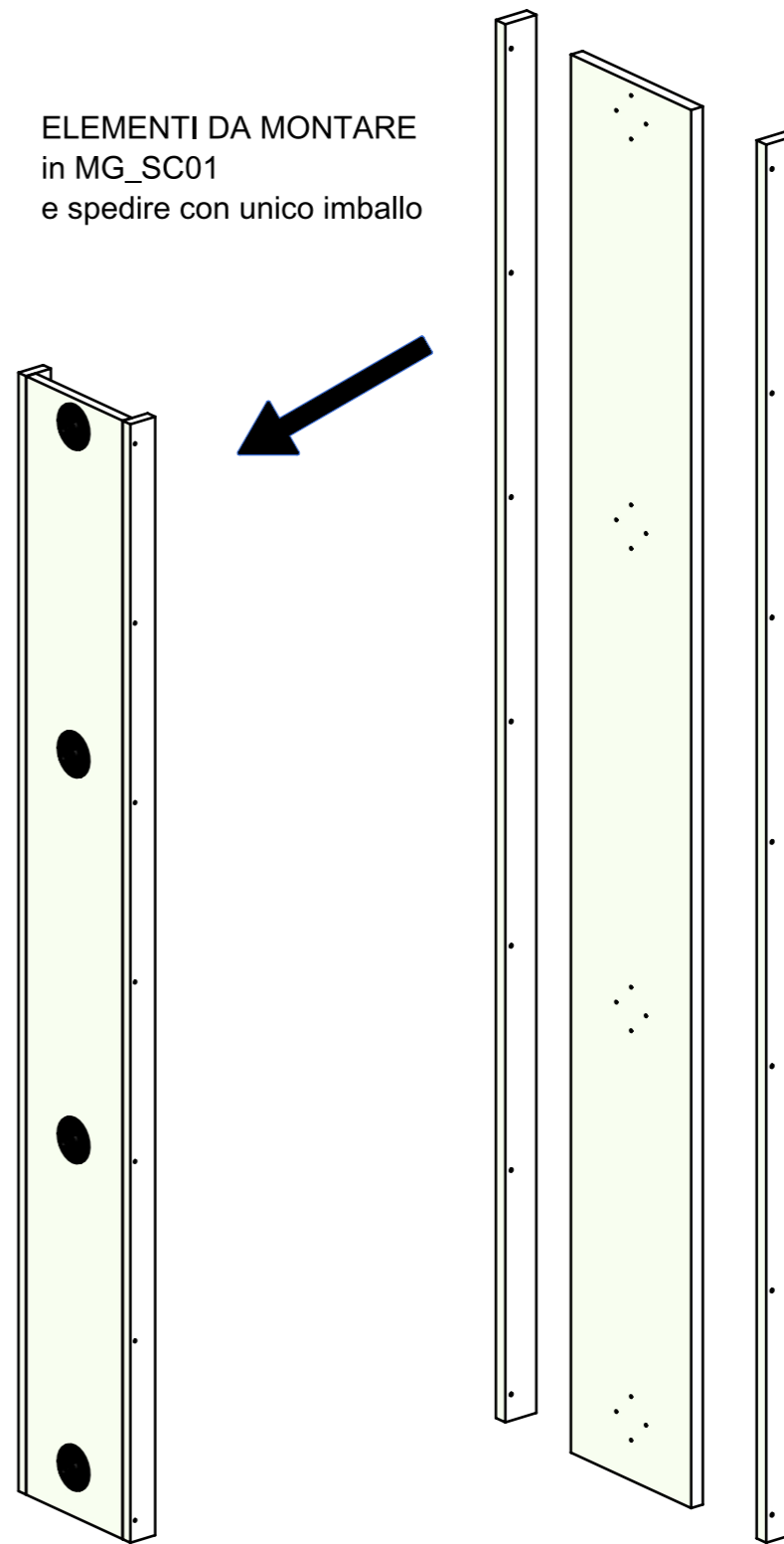

FERRAMENTA	QTY
FITLOCK M_MASCHERPA_3MM_6020202101	4

● = FILI RASATI

● = VERNICIARE 1 LATO + FILI RASATI O BORDATI

NESSUN SIMBOLO = VERNICIARE 2 LATI + FILI RASATI O BORDATI

LOCALE	CODICE	DESCRIZIONE COMPONENTE	FINITURA	GR.
SALONE	MD320_MG_SD01	STRUTTURA MURATA DX POPPA		3

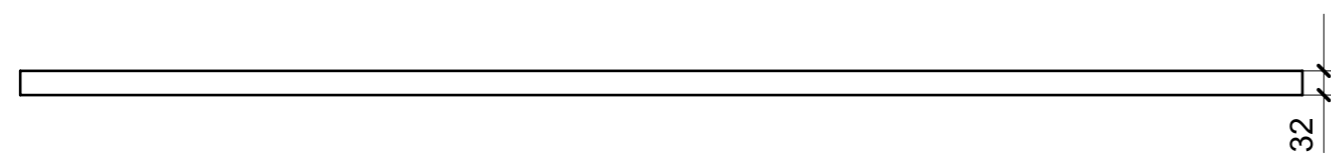
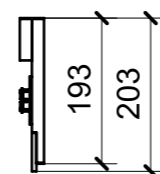
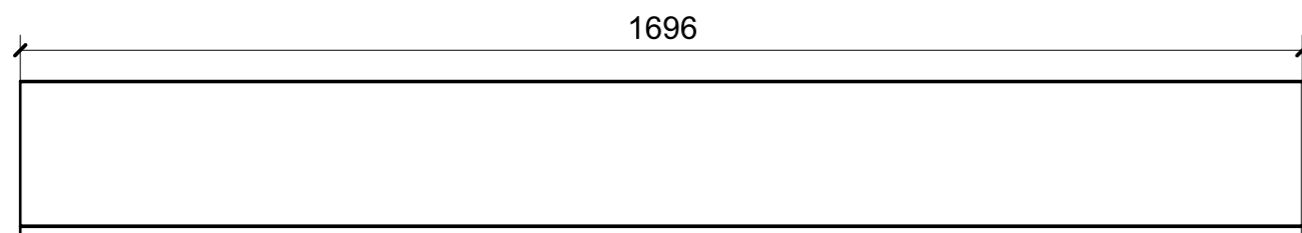
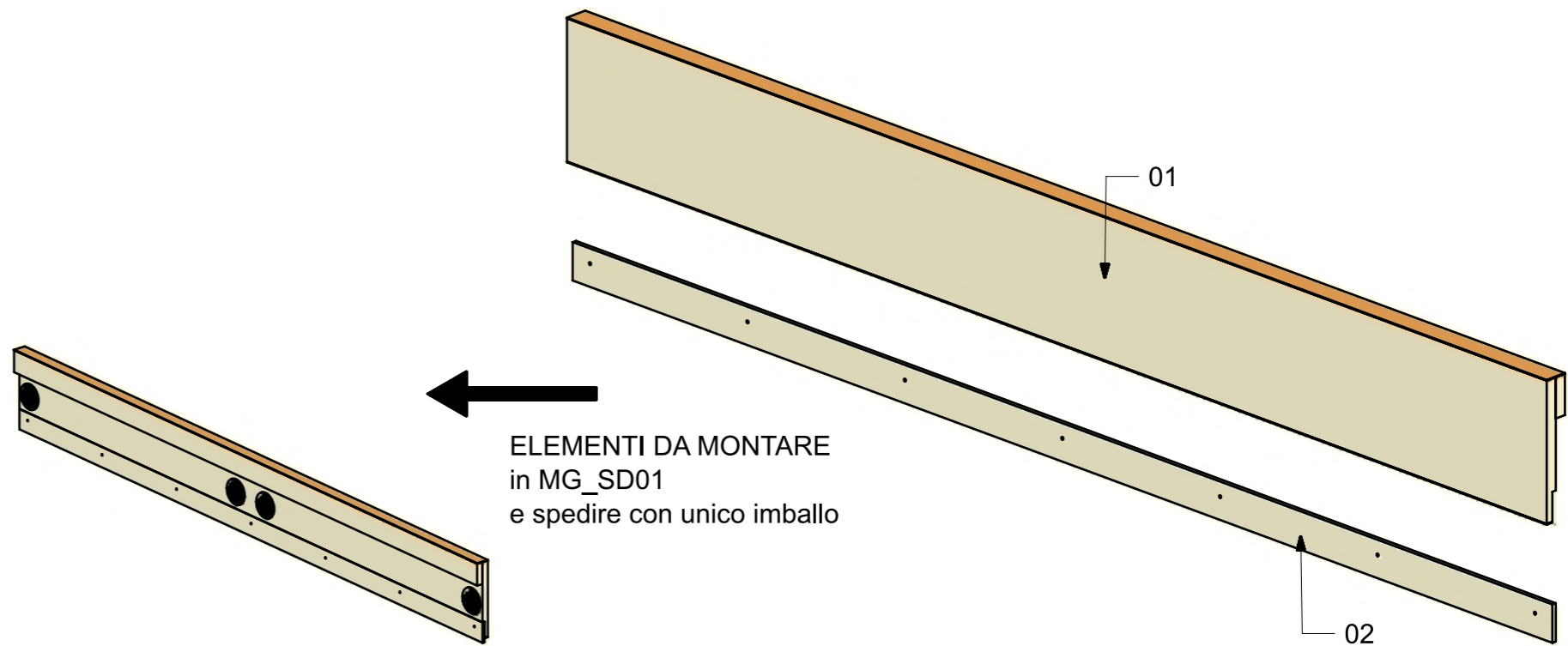

FERRAMENTA	QTY
FITLOCK M_MASCHERPA_3MM_6020202101	4

LOCALE	CODICE	DESCRIZIONE COMPONENTE	FINITURA	GR.
SALONE	MD320_MG_SE01	PLENUM MURATA DX POPPA	OKUME' GREZZO/GREZZO VERNICIATO ANTI ROMBO	3

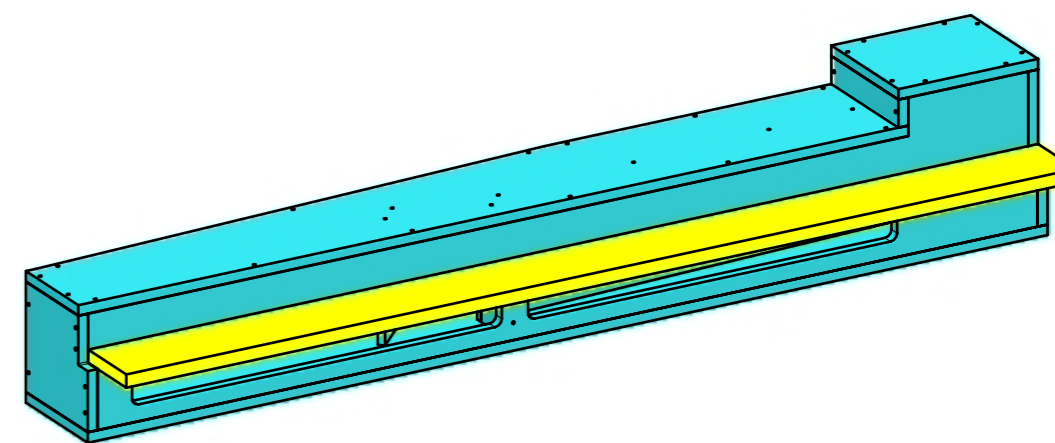
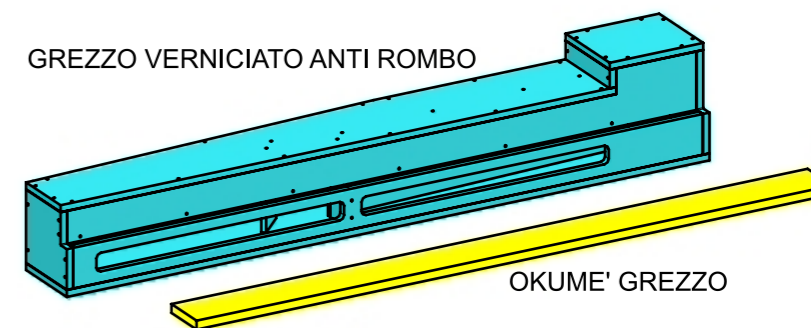
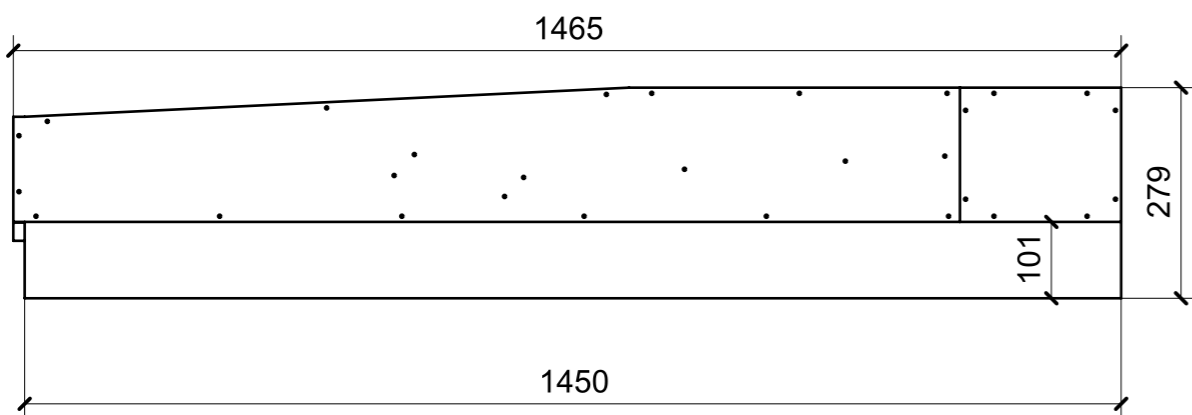
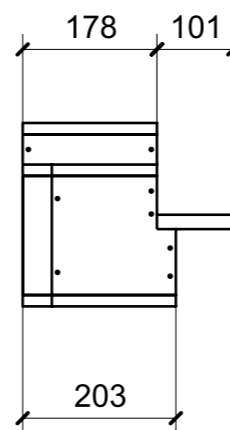
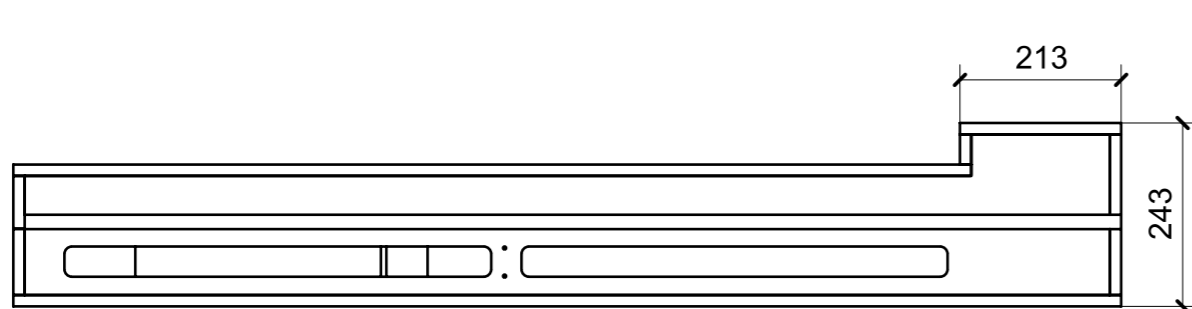

FERRAMENTA	QTY
BUSSOLA 6MA X 10 FORO DIAM.8	3

LOCALE	CODICE	DESCRIZIONE COMPONENTE	FINITURA	GR.
SALONE	MD320_MG_SF01	STRUTTURA MURATA SX PRUA	LASTRA CHIARA	3

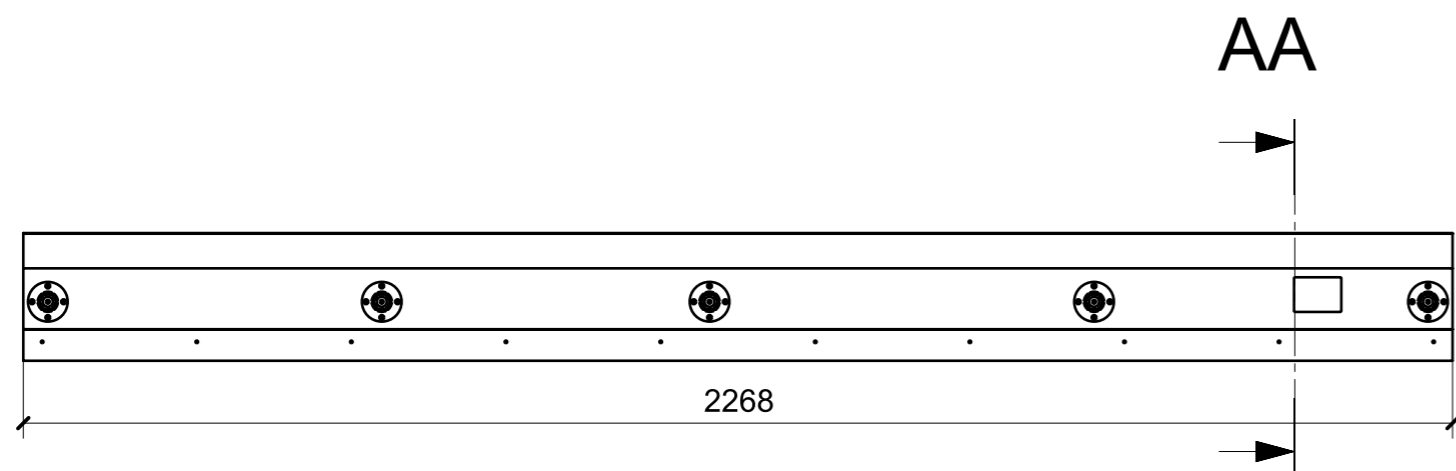

MG\_SF01

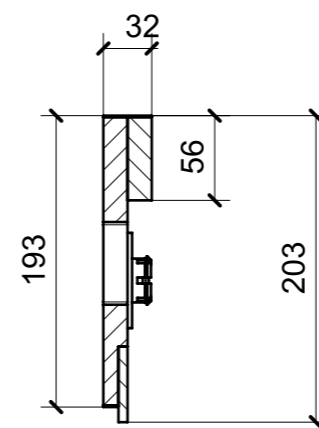

SECTION AA-AA

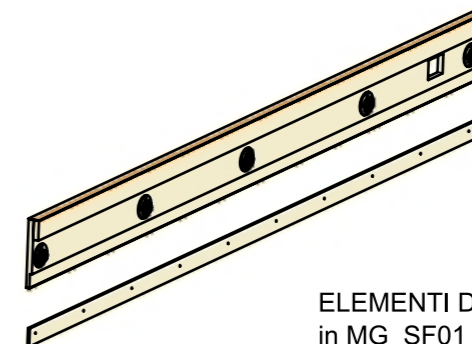

ELEMENTI DA MONTARE  
in MG\_SF01  
e spedire con unico imballo

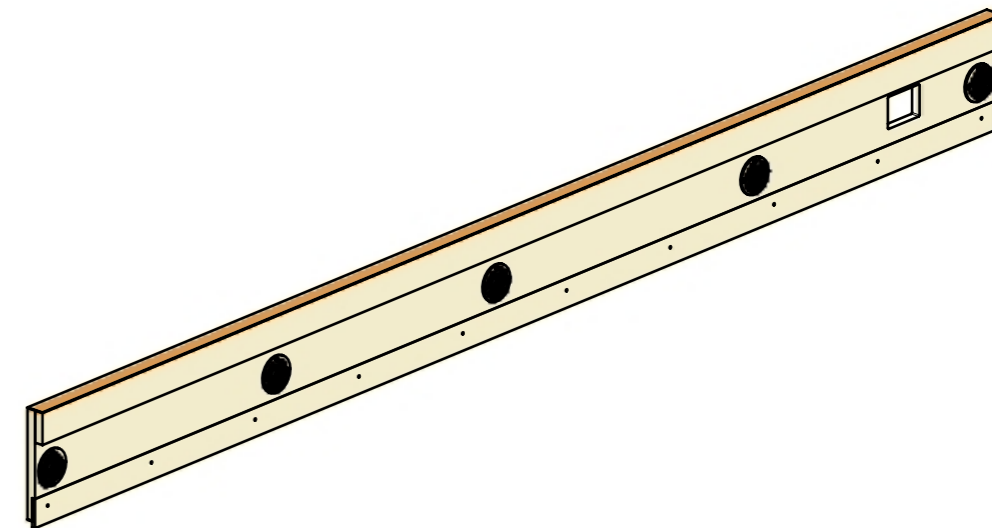

FERRAMENTA	QTY
FITLOCK M_MASCHERPA_3MM_6020202101	5

LOCALE	CODICE	DESCRIZIONE COMPONENTE	FINITURA	GR.
SALONE	MD320_MG_SG01	PLENUM MURATA SX PRUA		PTP

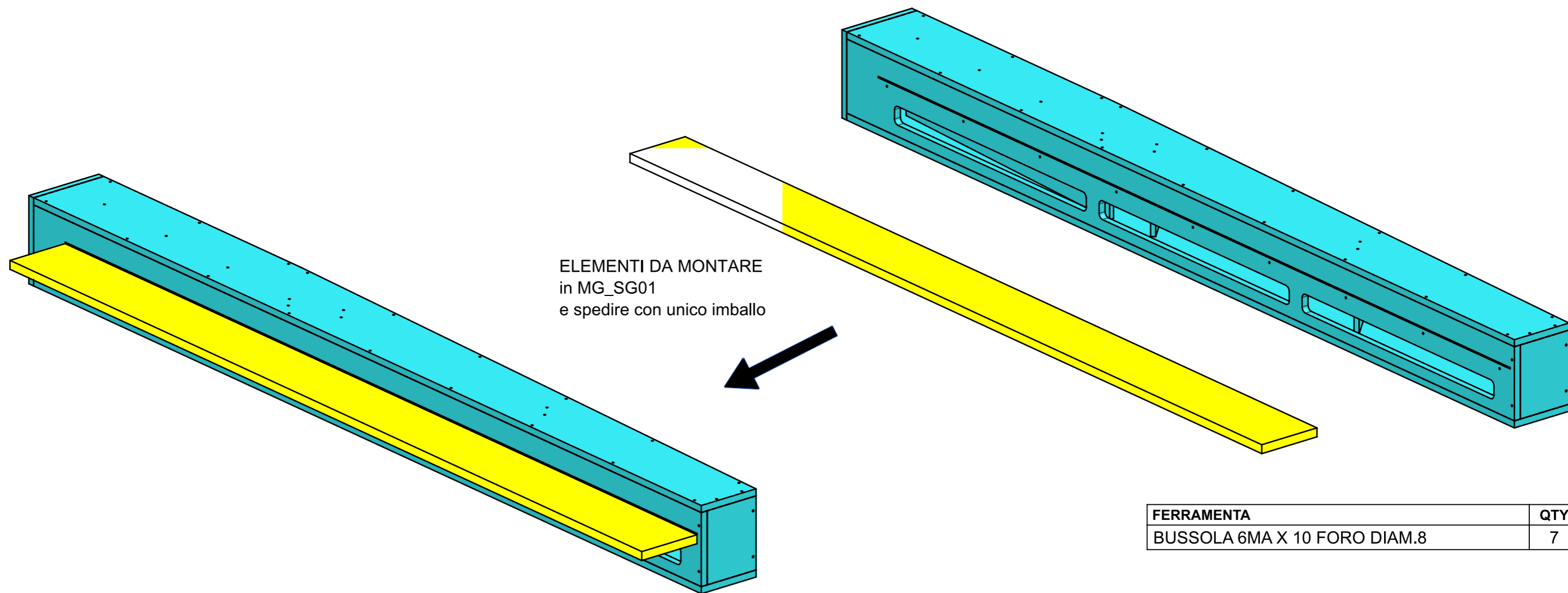

FERRAMENTA	QTY
BUSSOLA 6MA X 10 FORO DIAM.8	7

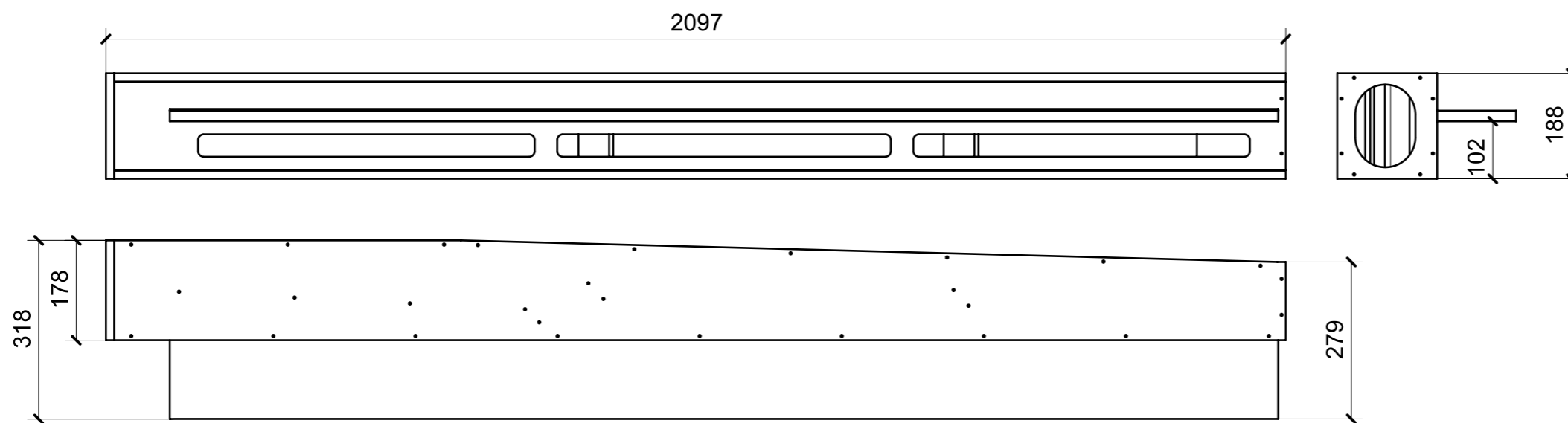

VERNICIATURA LASTRA/LACCATI:

● = FILI RASATI

● = VERNICIARE 1 LATO + FILI RASATI O BORDATI

NESSUN SIMBOLO = VERNICIARE 2 LATI + FILI RASATI O BORDATI

LOCALE	CODICE	DESCRIZIONE COMPONENTE	FINITURA	GR.
SALONE	MD320_MG_SH01	STRUTTURA MONTANTE SX		PTP

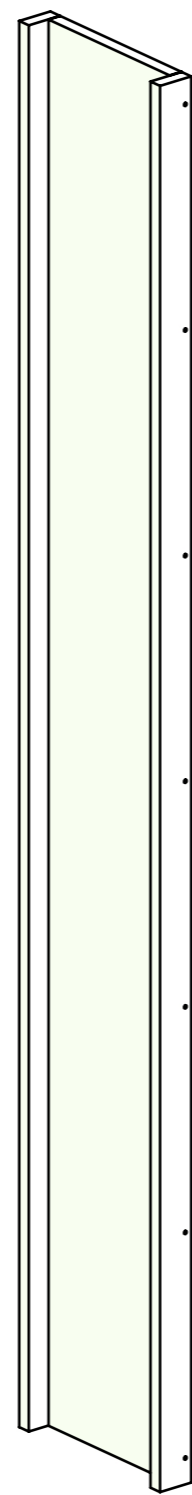
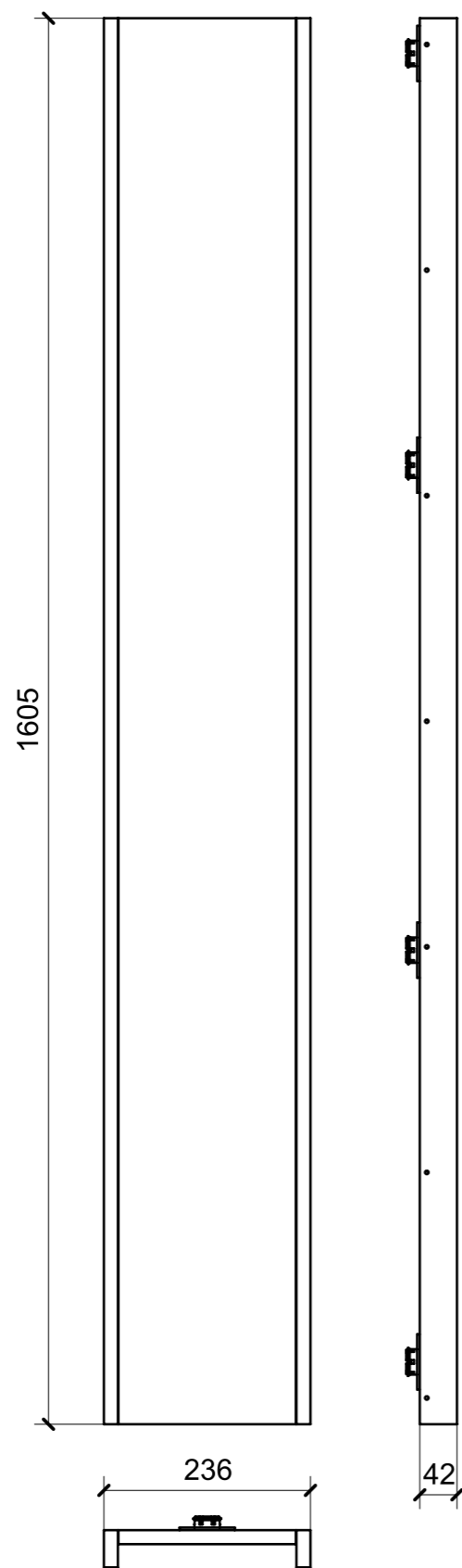

ELEMENTI DA MONTARE  
in MG\_SH01  
e spedire con unico imballo

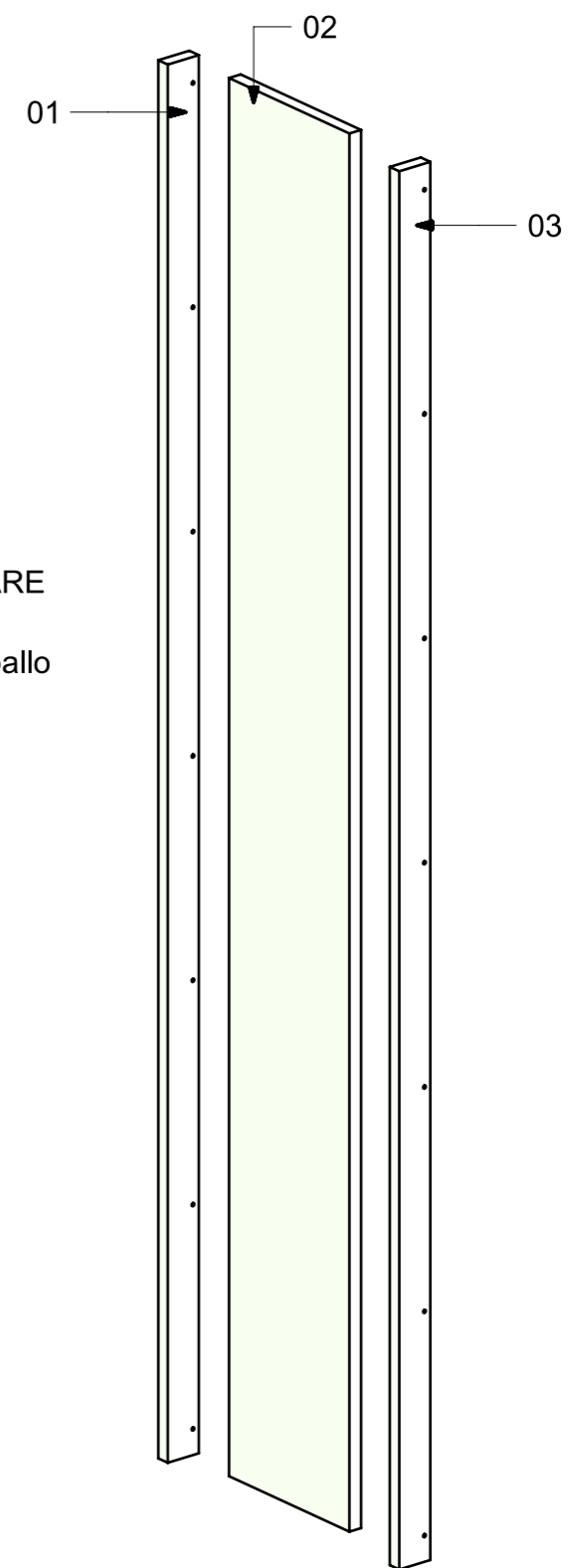

VERNICIATURA LASTRA/LACCATI:

● = FILI RASATI

● = VERNICIARE 1 LATO + FILI RASATI O BORDATI

NESSUN SIMBOLO = VERNICIARE 2 LATI + FILI RASATI O BORDATI

LOCALE	CODICE	DESCRIZIONE COMPONENTE	FINITURA	GR.
SALONE	MD320_MG_SI01	STRUTTURA MURATA SX POPPA	LASTRA CHIARA	3

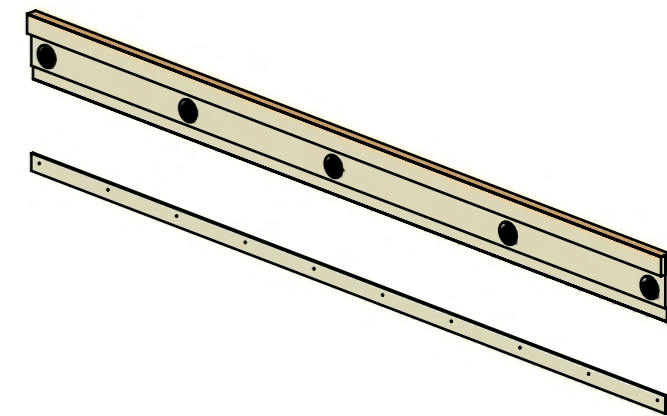
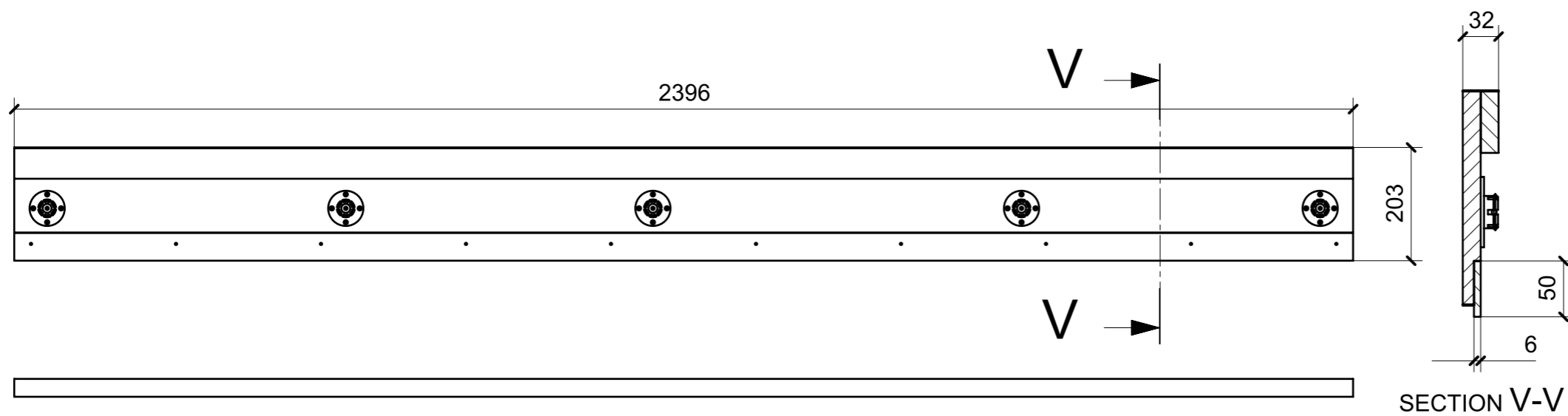

ELEMENTI DA MONTARE  
in MG\_SI01  
e spedire con unico imballo

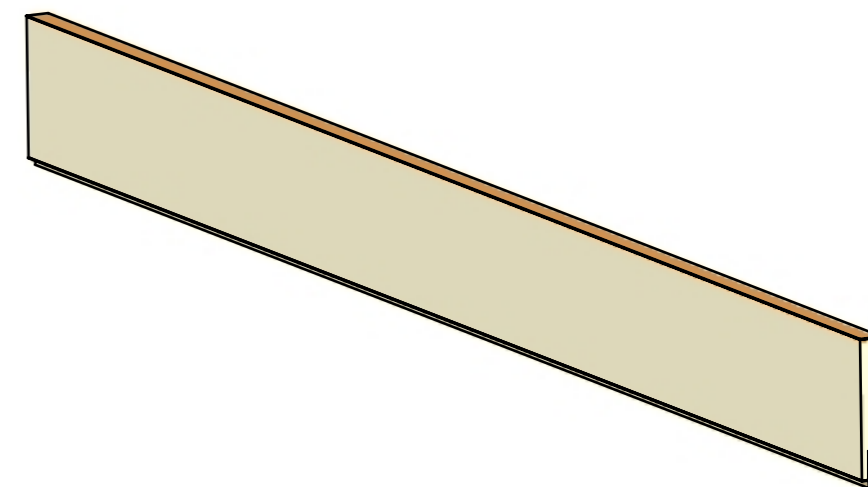
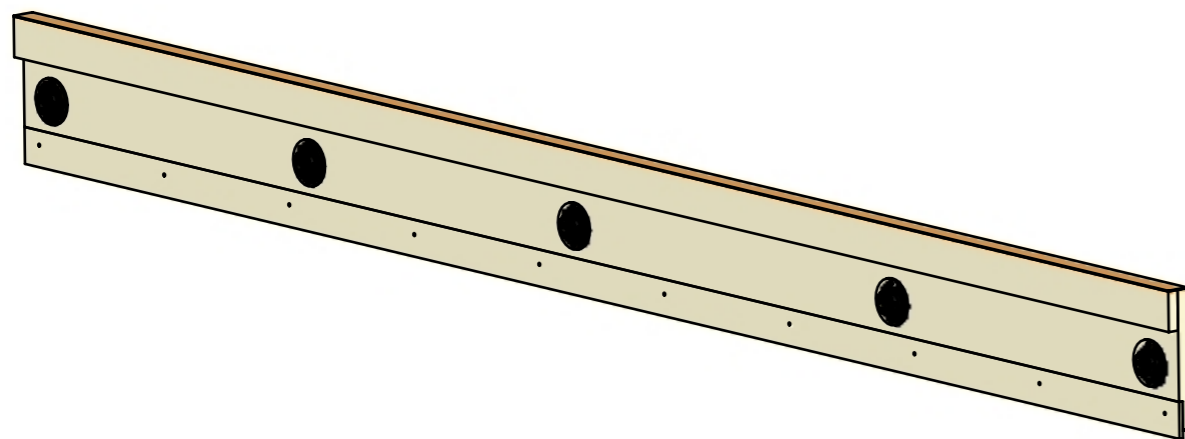

FERRAMENTA	QTY
FITLOCK M_MASCHERPA_3MM_6020202101	5

LOCALE	CODICE	DESCRIZIONE COMPONENTE	FINITURA	GR.
SALONE	MD320_MG_SL01	PLENUM MURATA SX POPPA		PTP

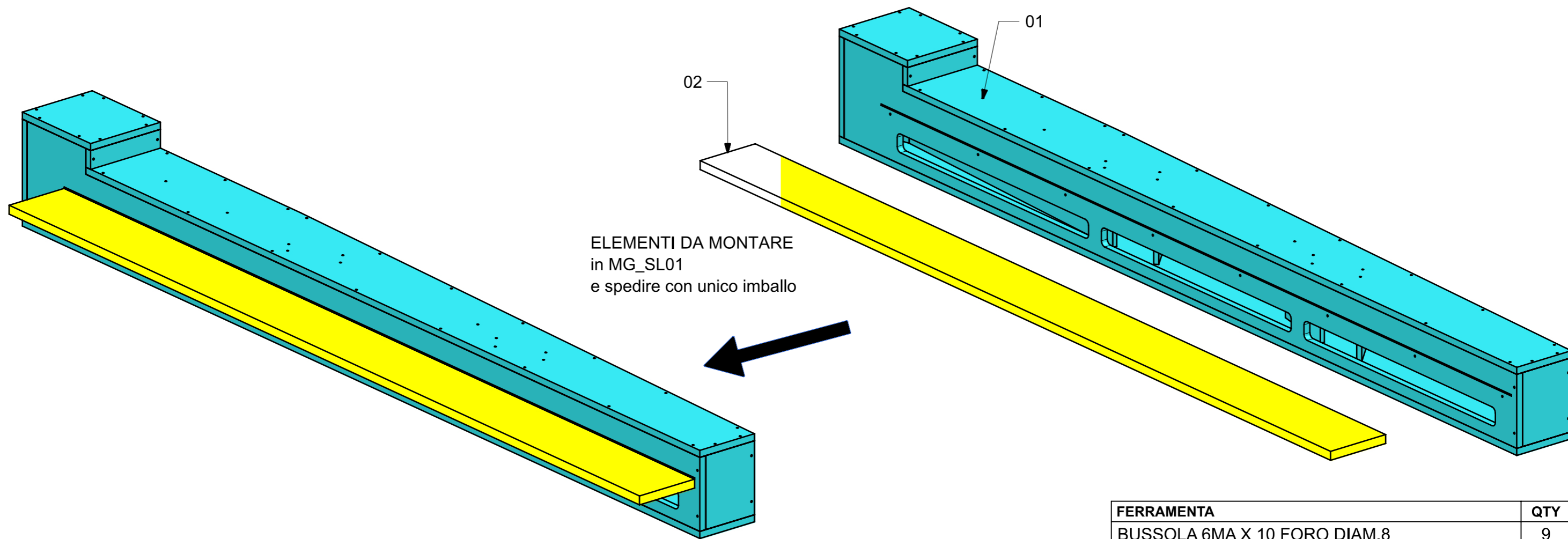

ELEMENTI DA MONTARE  
in MG\_SL01  
e spedire con unico imballo

FERRAMENTA	QTY
BUSSOLA 6MA X 10 FORO DIAM.8	9

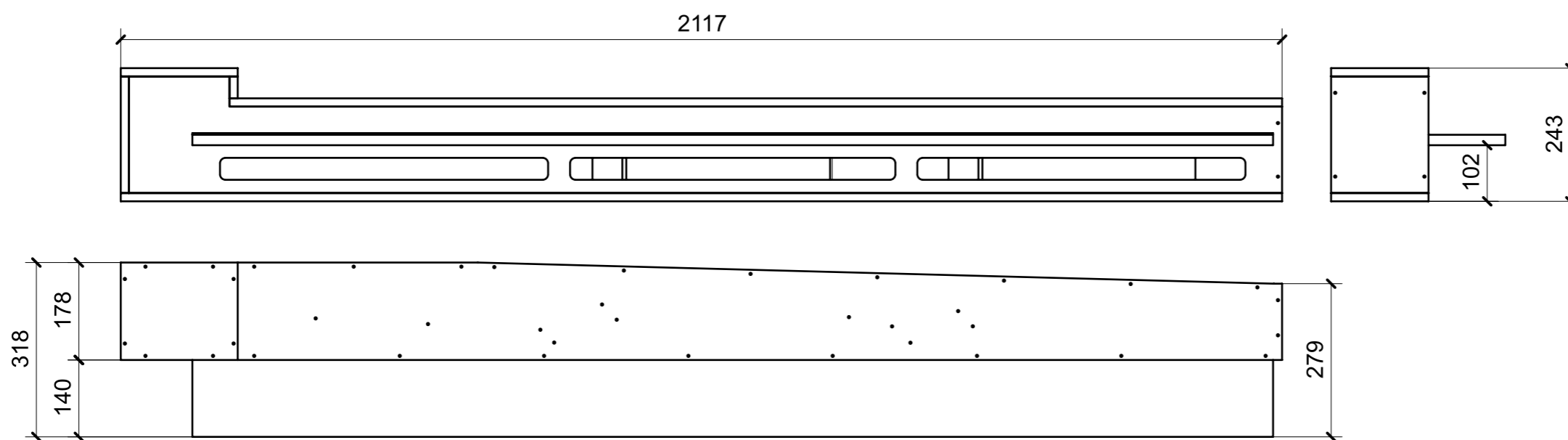

VERNICIATURA LASTRA/LACCATI:

● = FILI RASATI

● = VERNICIARE 1 LATO + FILI RASATI O BORDATI

NESSUN SIMBOLO = VERNICIARE 2 LATI + FILI RASATI O BORDATI

LOCALE	CODICE	DESCRIZIONE COMPONENTE	FINITURA	GR.
SALONE	MD320_MG_SM01	MOBILE COLONNA SX POPPA	LAMINATO SMART 0180-2 JUNGLE	4

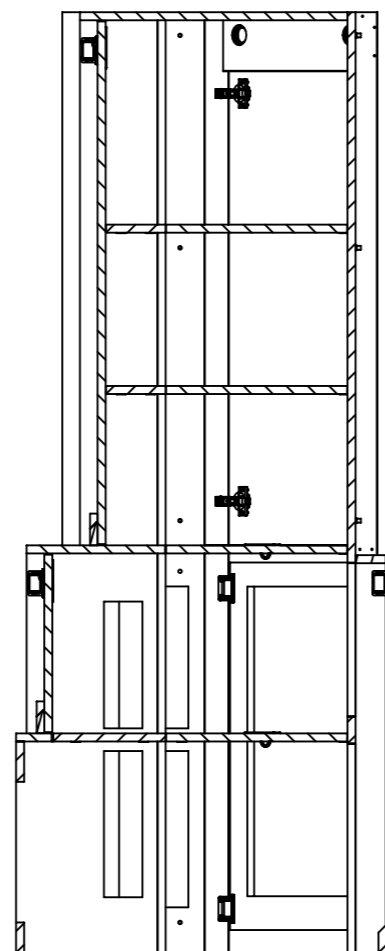
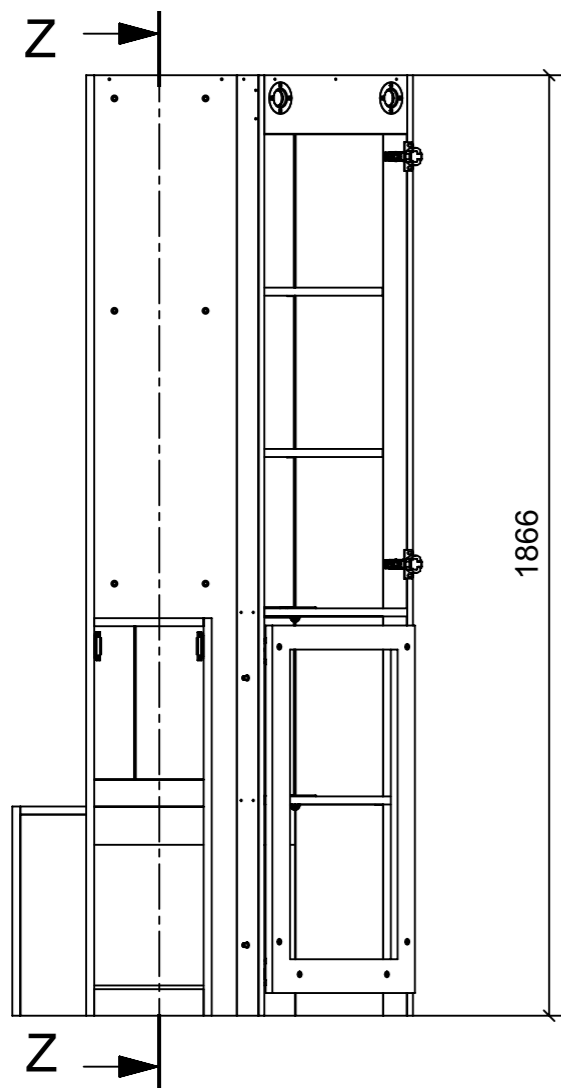

SECTION Z-Z

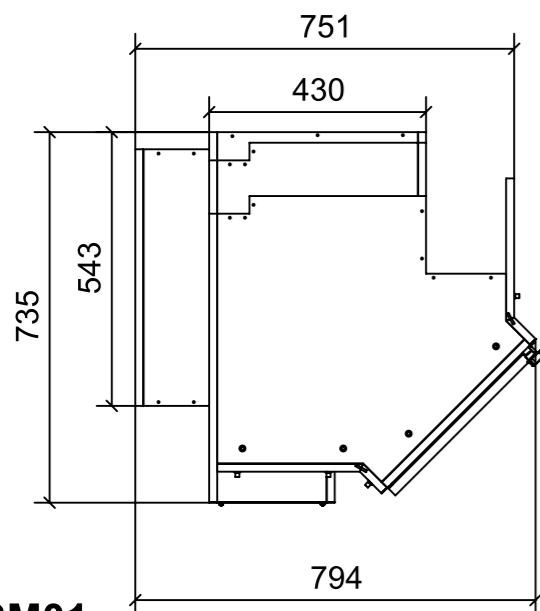
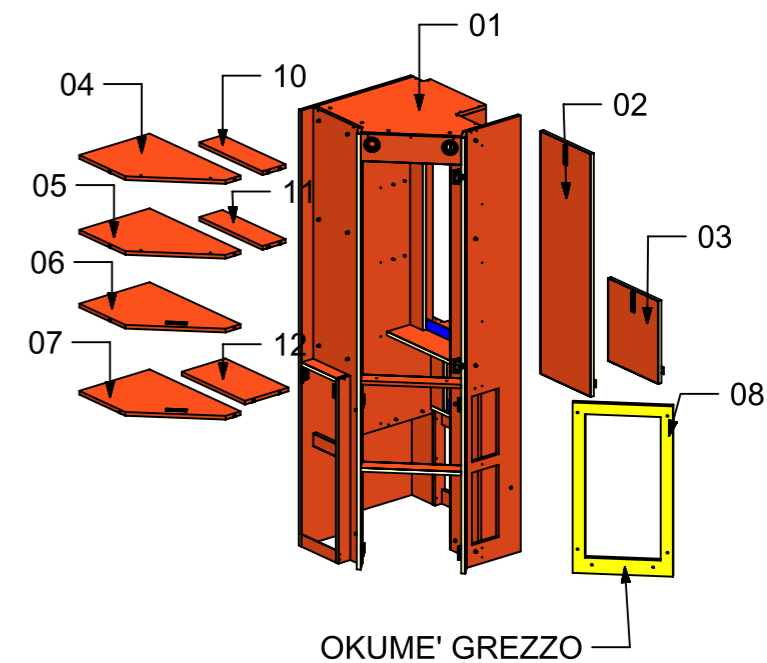
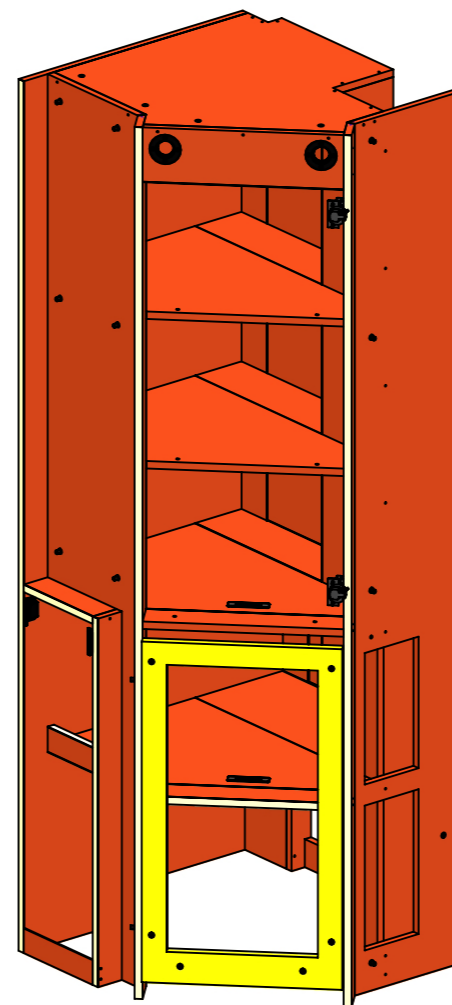

MG\_SM01

FERRAMENTA	QTY
MAGNETE FORZA MAGNETICA1-5 10KG_HAFELE_246.87.112	2
ALZAPAGLIOLI_FORESTI_164.B BRUNITON	4
BASE_3-NERA_HAFELE_342.22.067-BLUM_175H3130.STP	2
BUSSOLA 5MA ANKOR BORGHI	4
BUSSOLA 6MA X 10 FORO DIAM.8	23
CERNIERA 94°_PIANA-NERA_HAFELE_342.46.604-BLUM_71B9550.STP	2
CHIUSURA A SPINTA_TECHNOPARTNER_SOU C3-203	10
FITLOCK F_MASCHERPA_6020101102	2
GIUNTO REGGIRIPIANO CON BORDO ANTISGANCIO_FBC BORGHI_1033XXB060902	23
PERNO LISCIO PER SPALLA_FBC BORGHI_1033PXX050531	21
VITE 4MA X 10 TESTA SVASATA ESAGONALE NERA	8
VITE 4MAX8 ANKOR BORGHI	4

LOCALE	CODICE	DESCRIZIONE COMPONENTE	FINITURA	GR.
SALONE	MD320_MG_SQ01	MOBILE CURVO INGRESSO DX POPPA		4

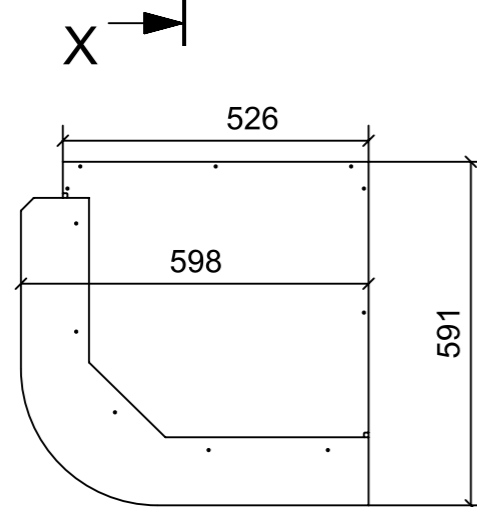
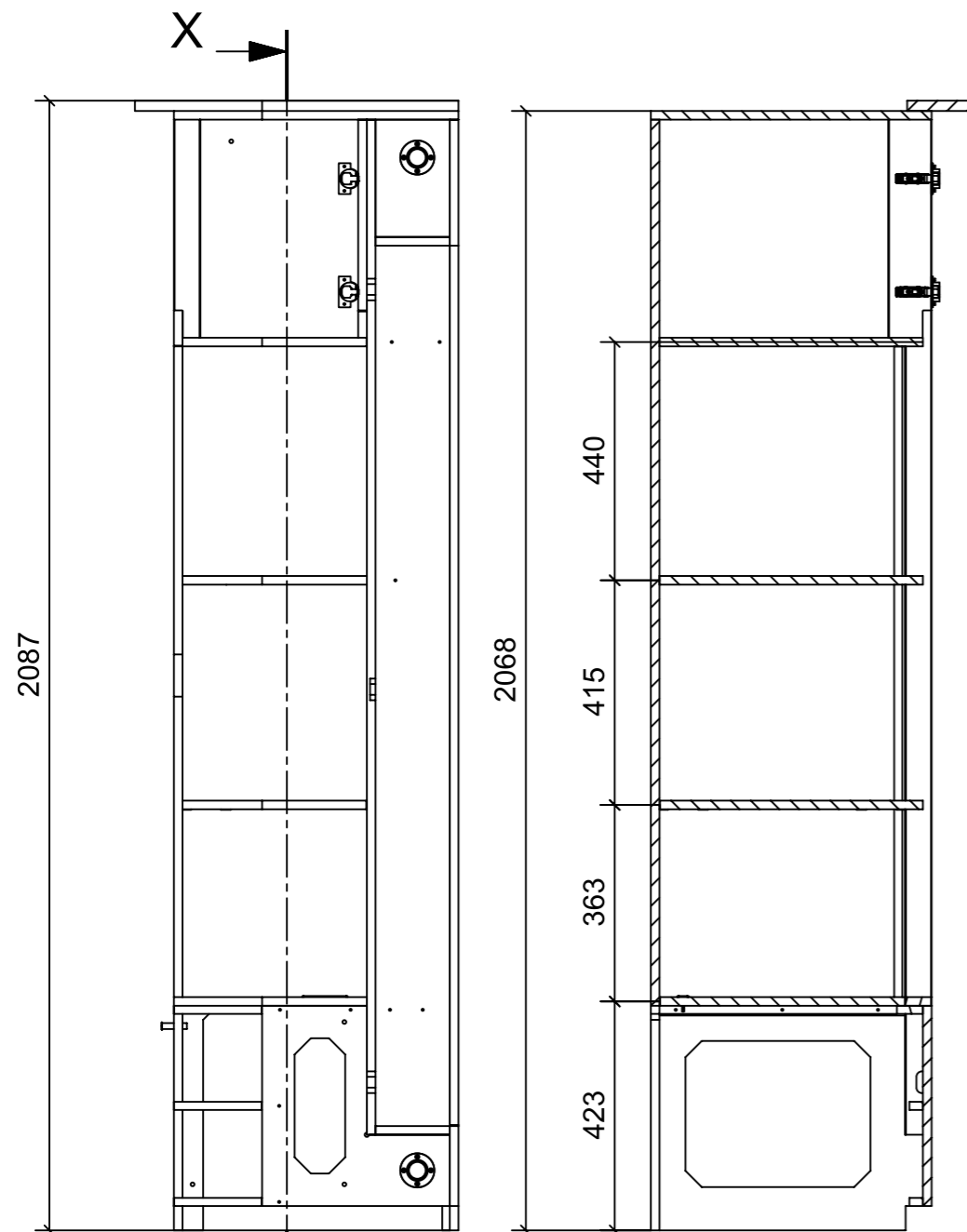

SECTION X-X

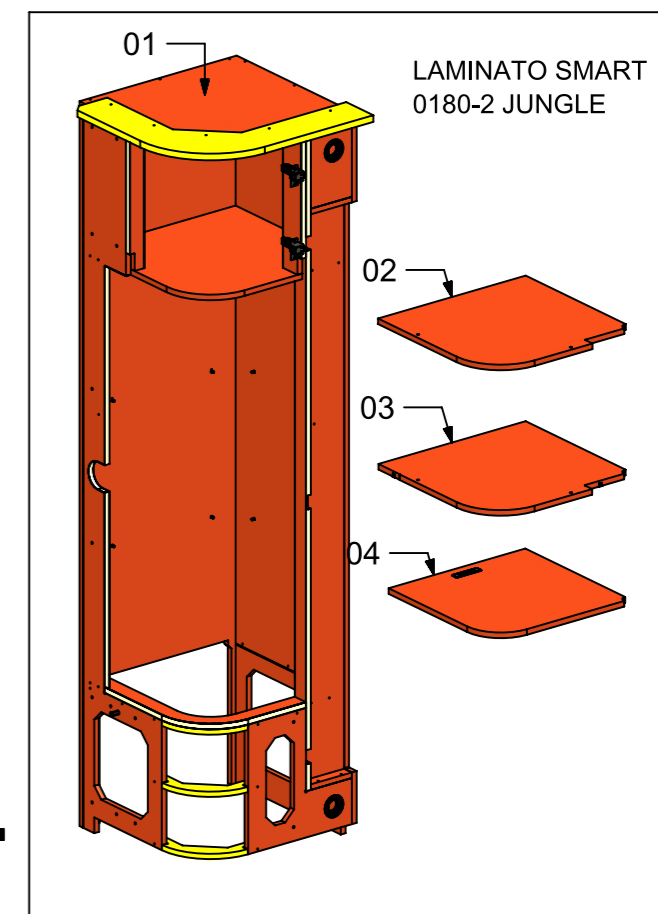
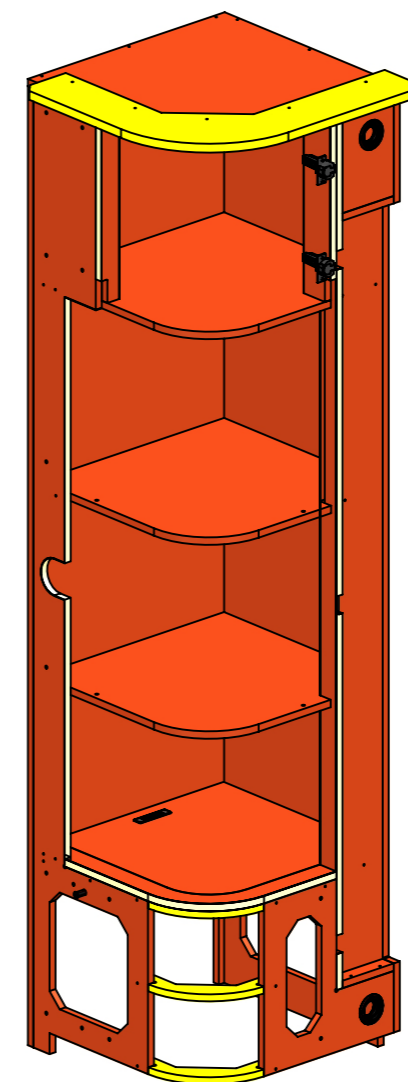

ELEMENTI DA MONTARE  
in MG\_SQ01  
e spedire con unico imballo

FERRAMENTA	QTY
SENSORE RETROANTA_HAFELE_833_89_334	1
ALZAPAGLIOLI_FORESTI_164.B BRUNITON	1
BASE_0-NERA_HAFELE_342.22.065-BLUM_175H3100.STP	2
BUSSOLA 5MA ANKOR BORGHI X BASE 0	4
BUSSOLA 6MA X 10 FORO DIAM.8	2
CERNIERA 94°_MEZZO COLLO-NERA_HAFELE_342.46.605-BLUM_71B9650	2
FITLOCK F_MASCHERPA_6020101102	2
GIUNTO REGGIRIPIANO CON BORDO ANTISGANCIIO_FBC BORGHI_1033XXB060902	6
KIT LED PER ARMADIO MD320 SQ01 MM 1202	1
PERNO LISCIIO PER SPALLA_FBC BORGHI_1033PXX050531	12
VITE 4MA X 10 TESTA SVASATA ESAGONALE NERA	2
VITE 4MAX8 ANKOR BORGHI X BASE 0	4
VITE 4MAX8 ANKOR BORGHI X CERNIERA COLLO PIENO	4

LOCALE	CODICE	DESCRIZIONE COMPONENTE	FINITURA	GR.
SALONE	MD320_MG_SQ02	MOBILE CURVO INGRESSO DX POPPA		4

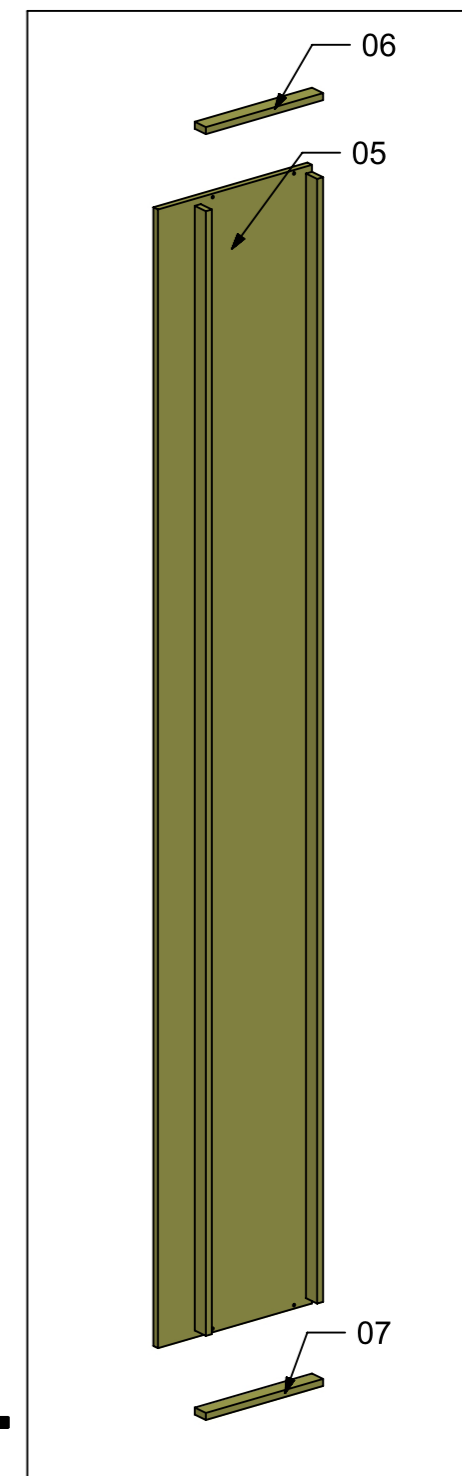
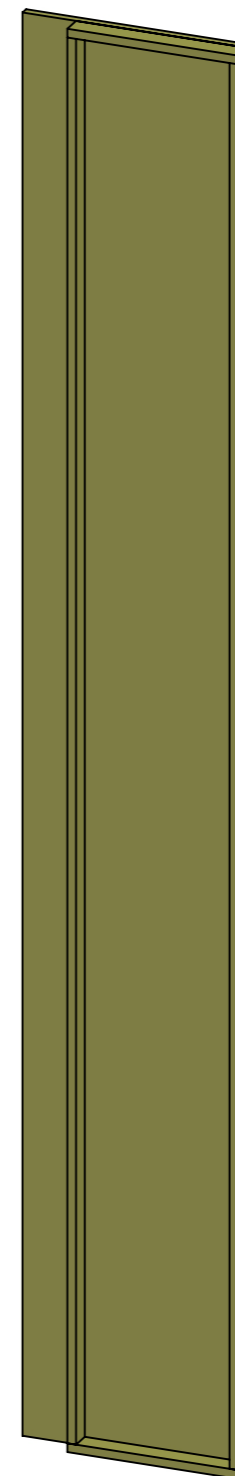
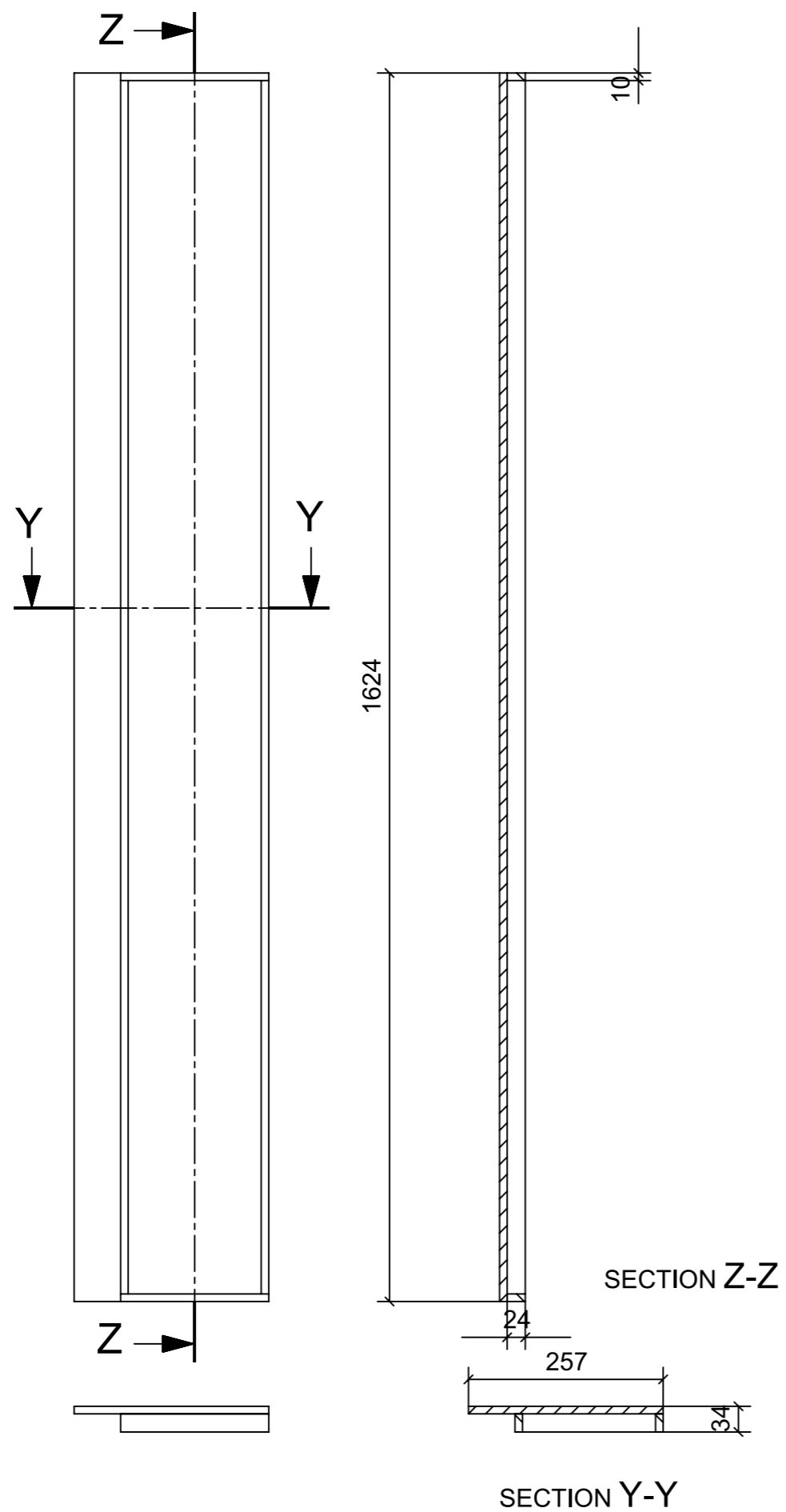

ELEMENTI DA MONTARE  
in MG\_SQ02  
e spedire con unico imballo