

LOCALE	CODICE	DESCRIZIONE COMPONENTE	FINITURA	GR.
LOBBY MD	MD320_CCA01	STRUT. LATO SX MOBILE RACK	OKUME' GREZZO	3

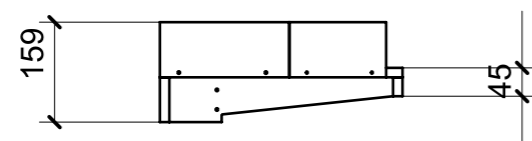

FERRAMENTA	QTY
BUSSOLA 6MA X 10 FORO DIAM.8	2
FITLOCK F_MASCHERPA_6020101102	10

LOCALE	CODICE	DESCRIZIONE COMPONENTE	FINITURA	GR.
LOBBY MD	MD320_CCB01	MOBILE RACK	LAMINATO SMART 0180-2 JUNGLE	4

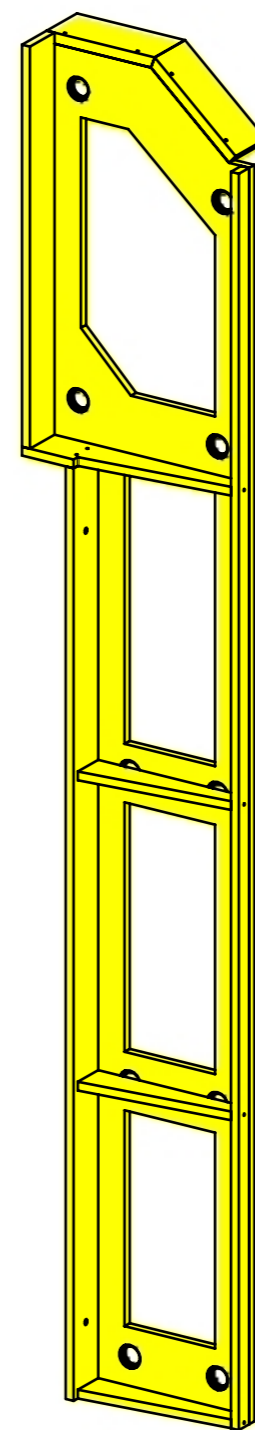
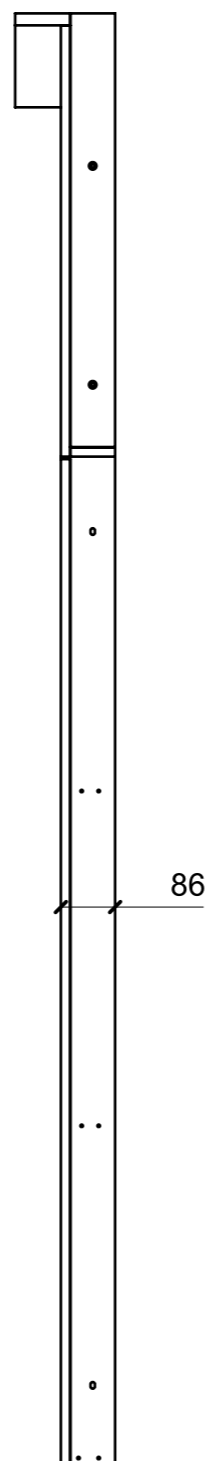
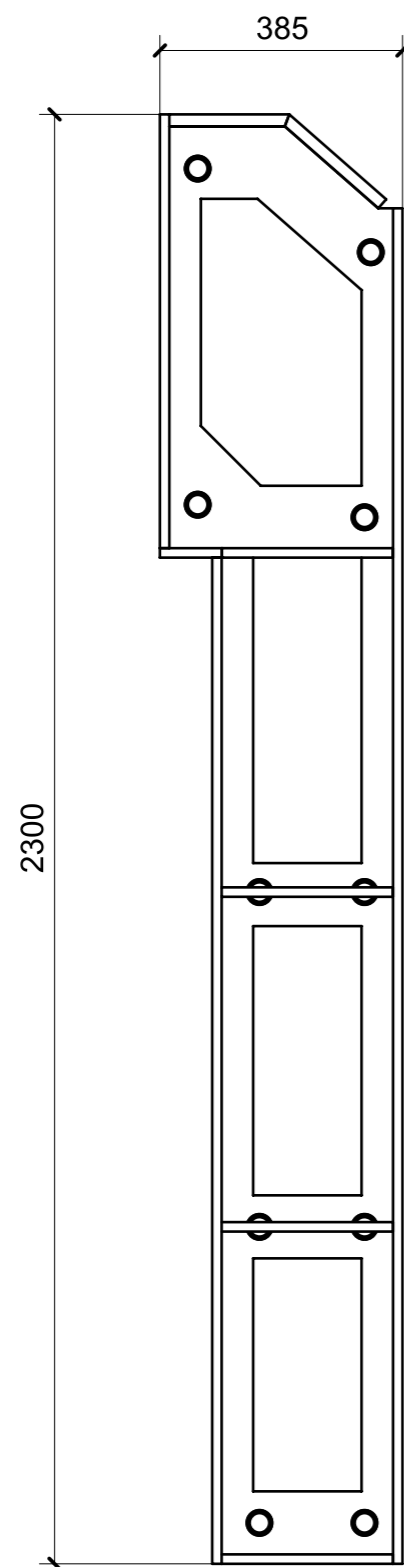
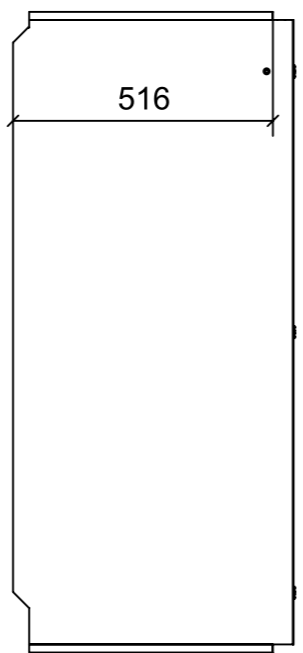
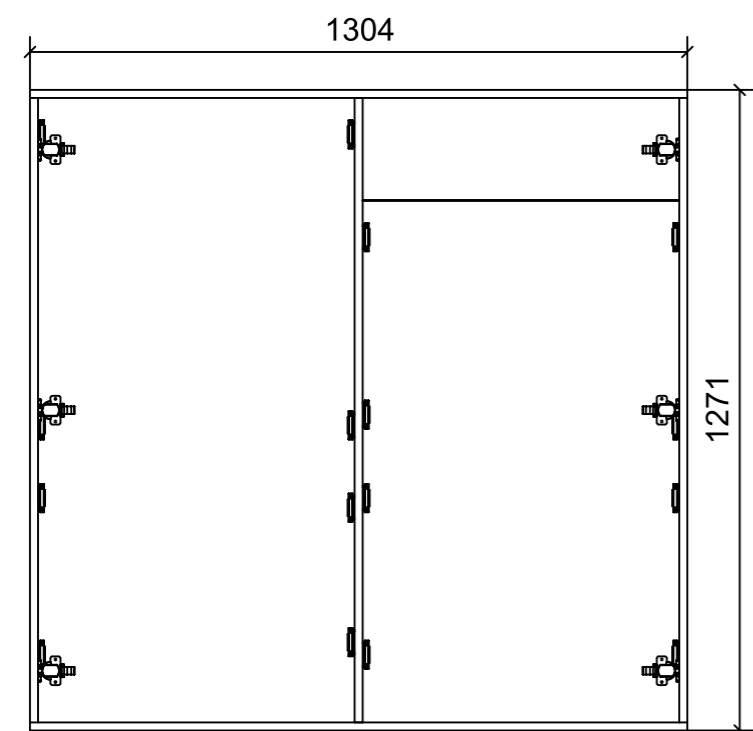
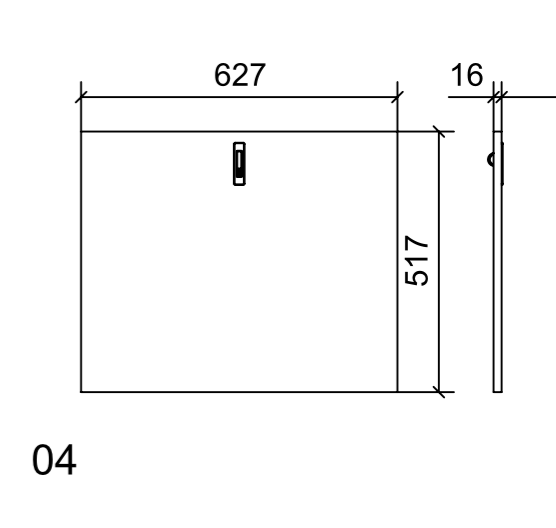
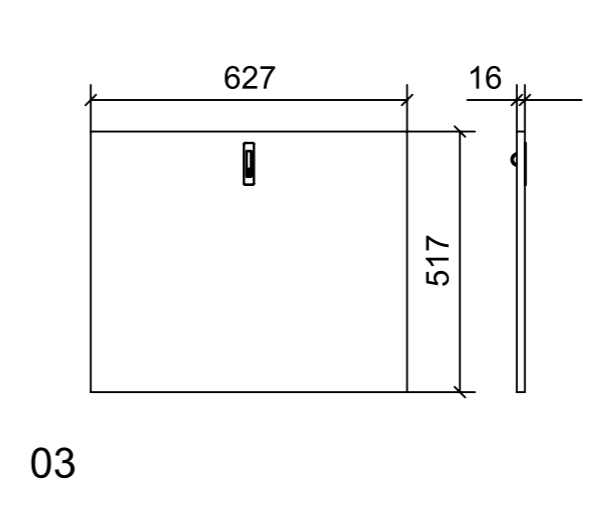
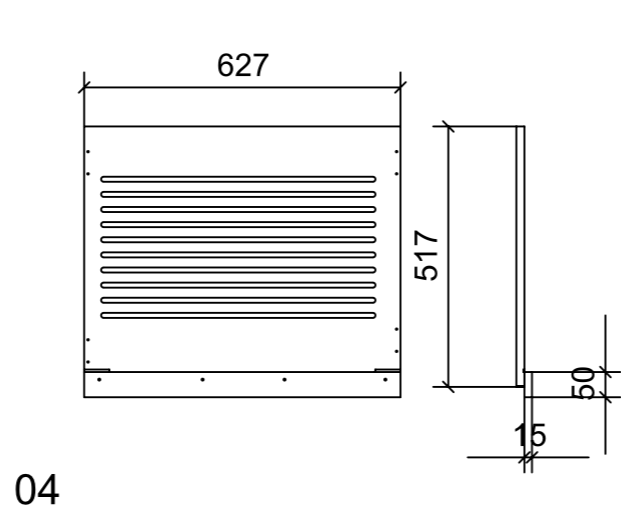
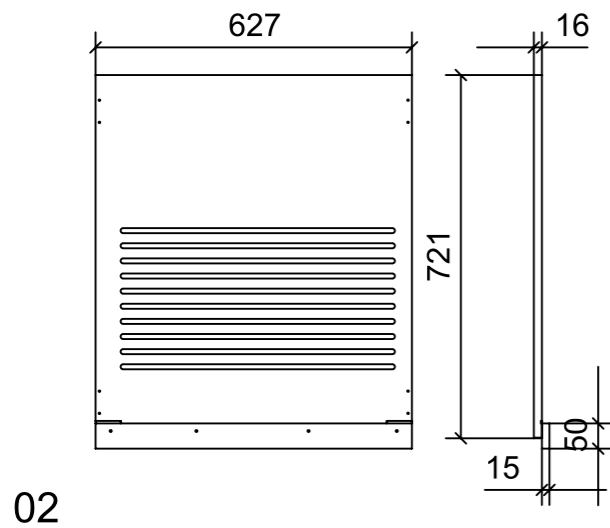

ELEMENTI DA MONTARE  
in MG\_CCB01  
e spedire con unico imballo

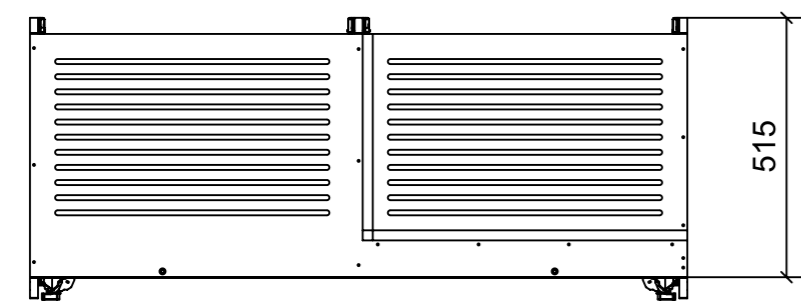
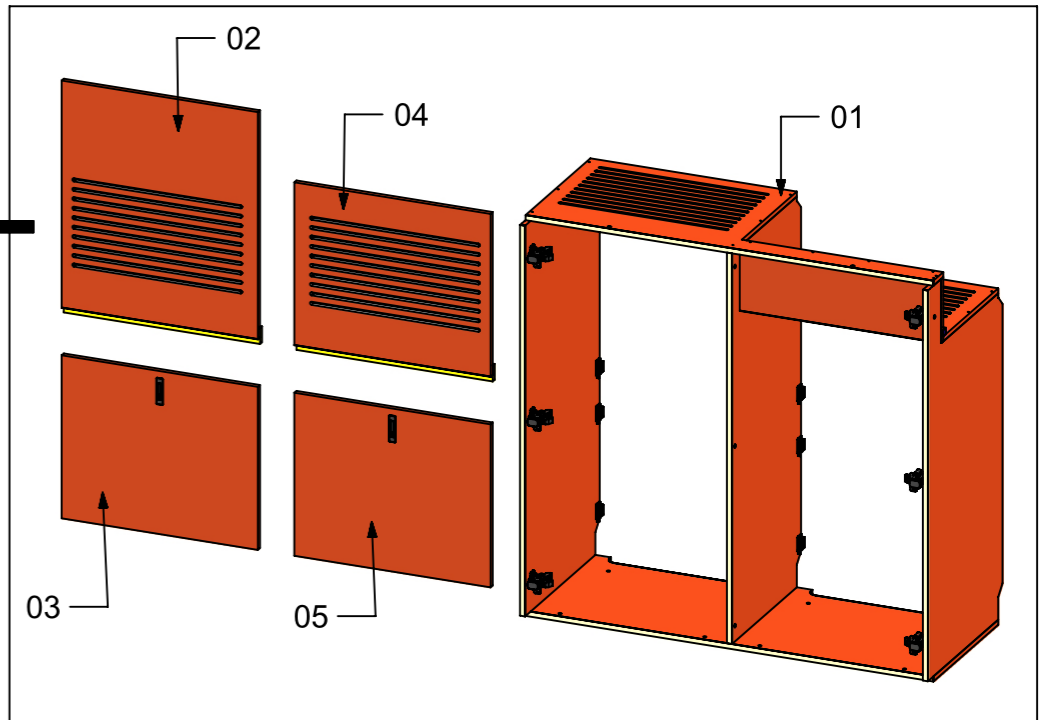
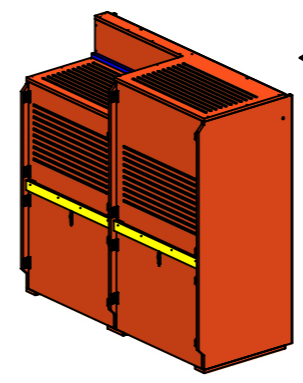

01

FERRAMENTA	QTY
ALZAPAGLIOLI_FORESTI_164.B BRUNITON	2
BASE_9-NERA_BLUM_175H9190	6
BUSSOLA 5MA ANKOR BORGHI	12
BUSSOLA 6MA X 10 FORO DIAM.8	7
CERNIERA 155°_MEZZO COLLO-NERA_BLUM_71B7650_ONS	6
CHIUSURA A SPINTA_TECHNOPARTNER_SOU C3-203	16
VITE 4MA X 10 TESTA SVASATA ESAGONALE NERA	4
VITE 4MAX8 NERA ANKOR BORGHI X BASE 9	12

LOCALE	CODICE	DESCRIZIONE COMPONENTE	FINITURA	GR.
LOBBY MD	MD320_CCC01	ZOCCOLO MOBILE RACK	OKUME' GREZZO/GREZZO SPRUZZATO NERO	2

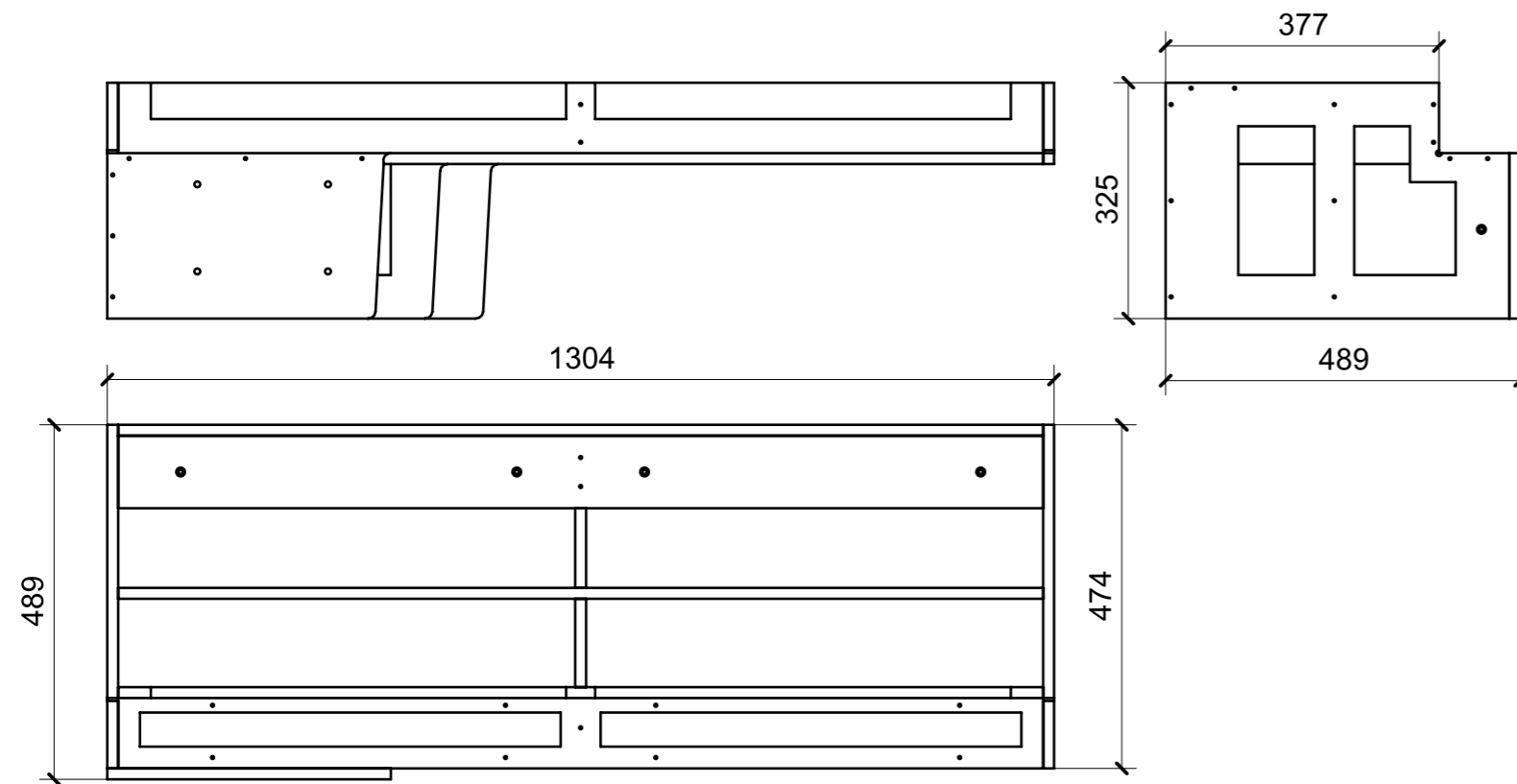

02

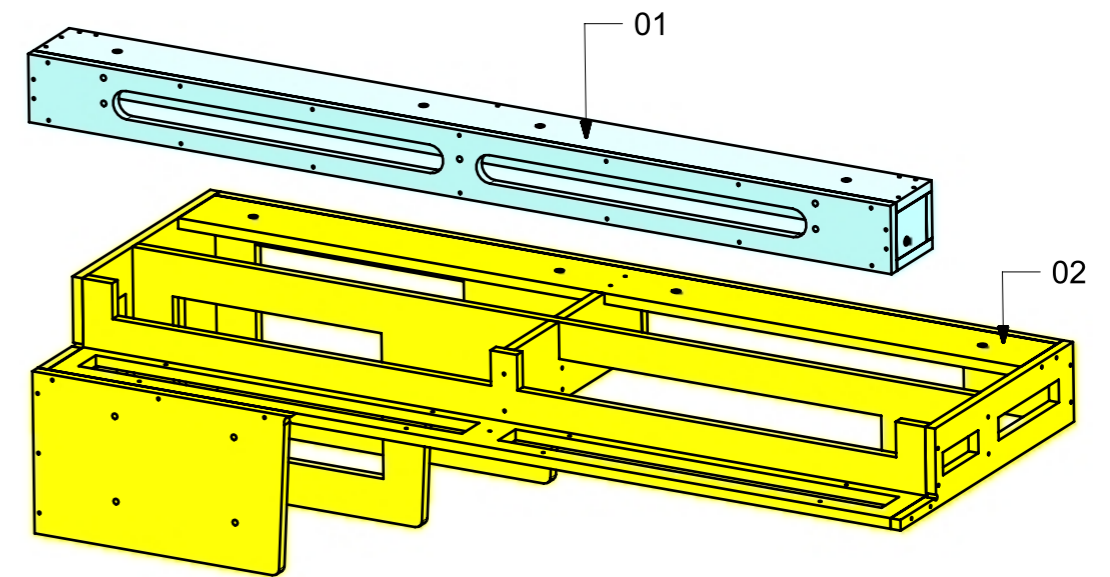

GREZZO SPRUZZATO NERO

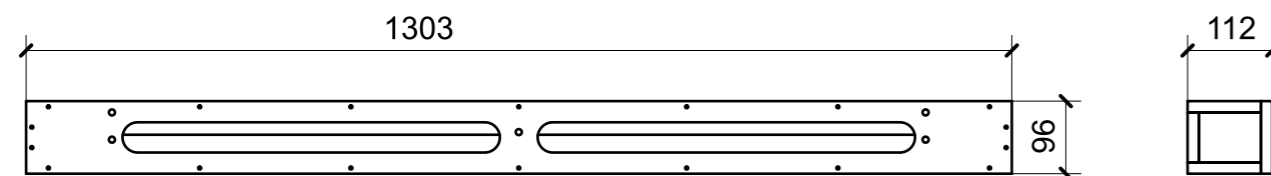

01

FERRAMENTA	QTY
BUSSOLA 6MA X 10 FORO DIAM.8	10

LOCALE	CODICE	DESCRIZIONE COMPONENTE	FINITURA	GR.
LOBBY MD	MD320_CCD01	STRUTTURA SUPERIORE MOBILE RACK	OKUME' GREZZO/GREZZO SPRUZZATO NERO	2

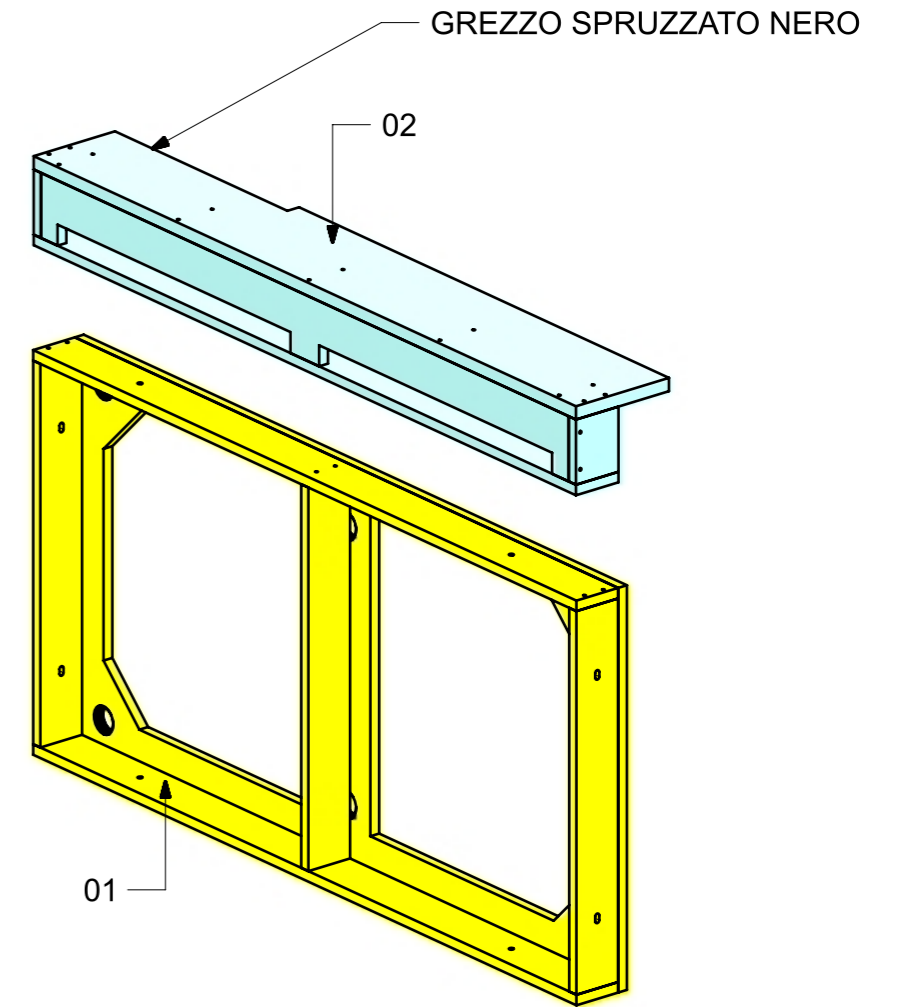
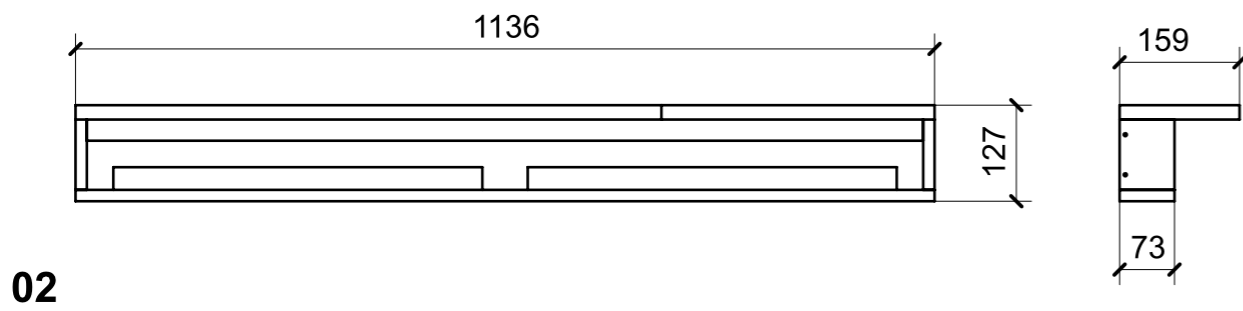
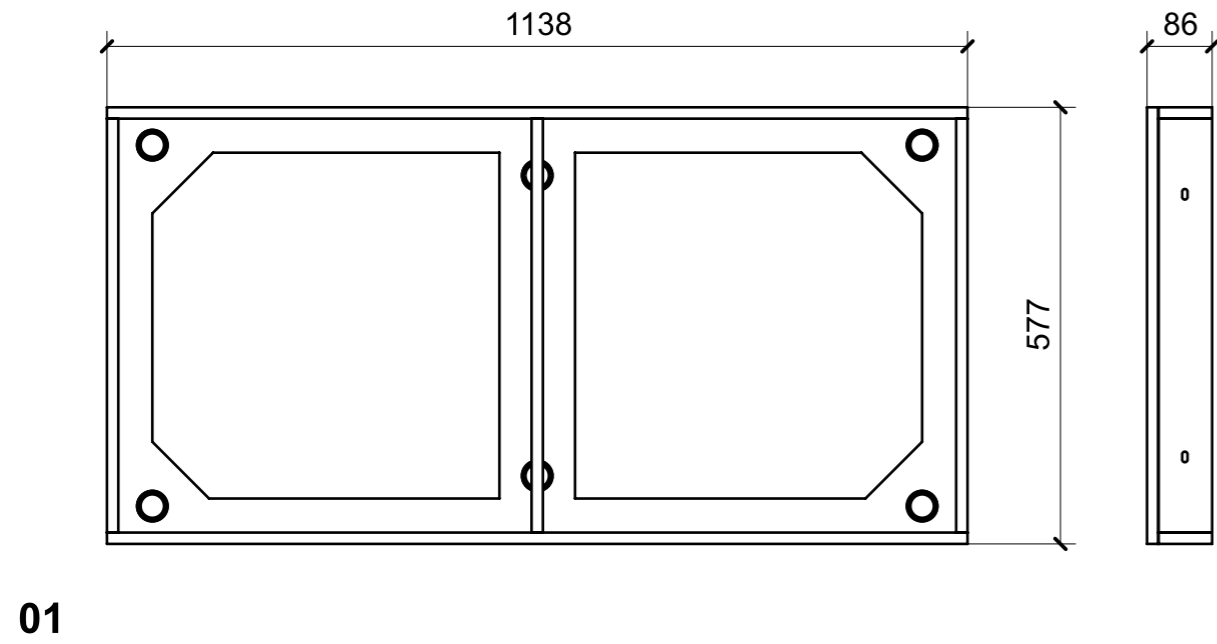

FERRAMENTA	QTY
FITLOCK F_MASCHERPA_6020101102	6

LOCALE	CODICE	DESCRIZIONE COMPONENTE	FINITURA	GR.
LOBBY MD	MD320_CCE01	STRUT. LATO DX MOBILE RACK	OKUME' GREZZO	PTP

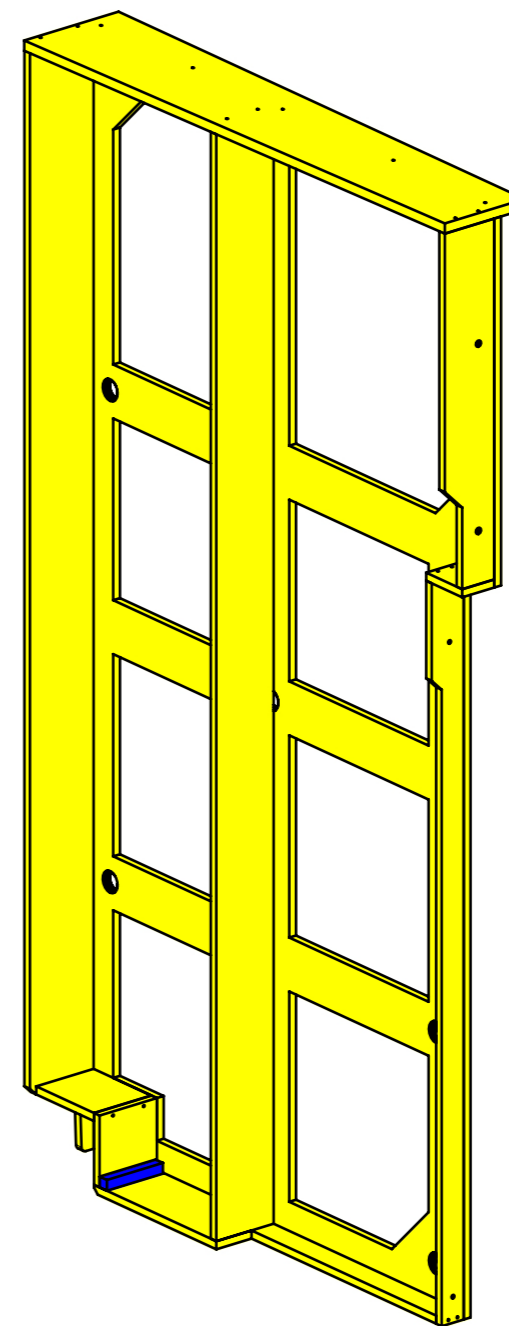
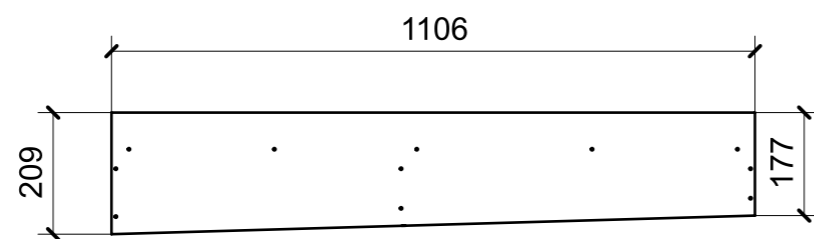
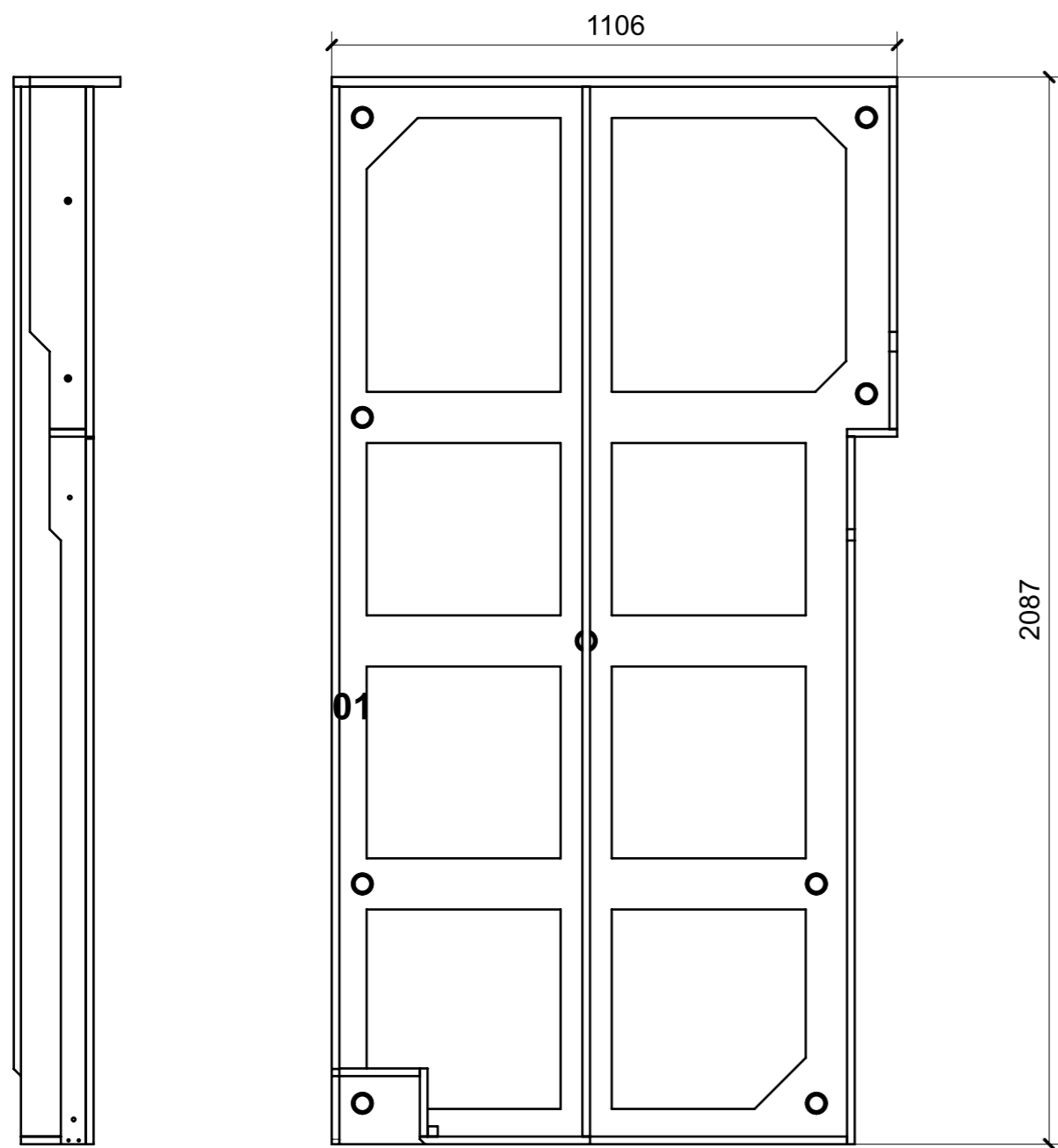

FERRAMENTA	QTY
BUSSOLA 6MA X 10 FORO DIAM.8	2
FITLOCK F_MASCHERPA_6020101102	9

LOCALE	CODICE	DESCRIZIONE COMPONENTE	FINITURA	GR.
LOBBY MD	MD320_CCF01	MOBILE AD ANGOLO INGRESSO SALONE	LAMINATO SMART 0180-2 JUNGLE	4

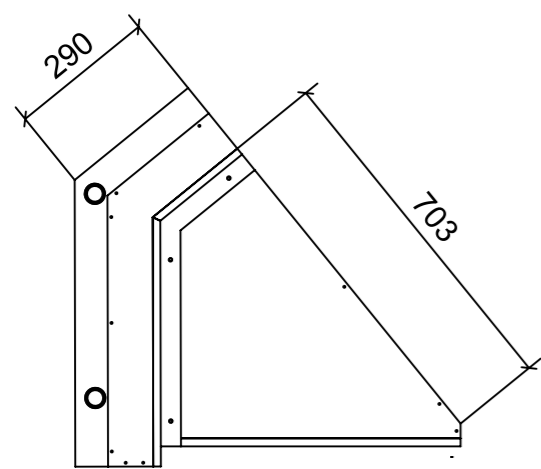
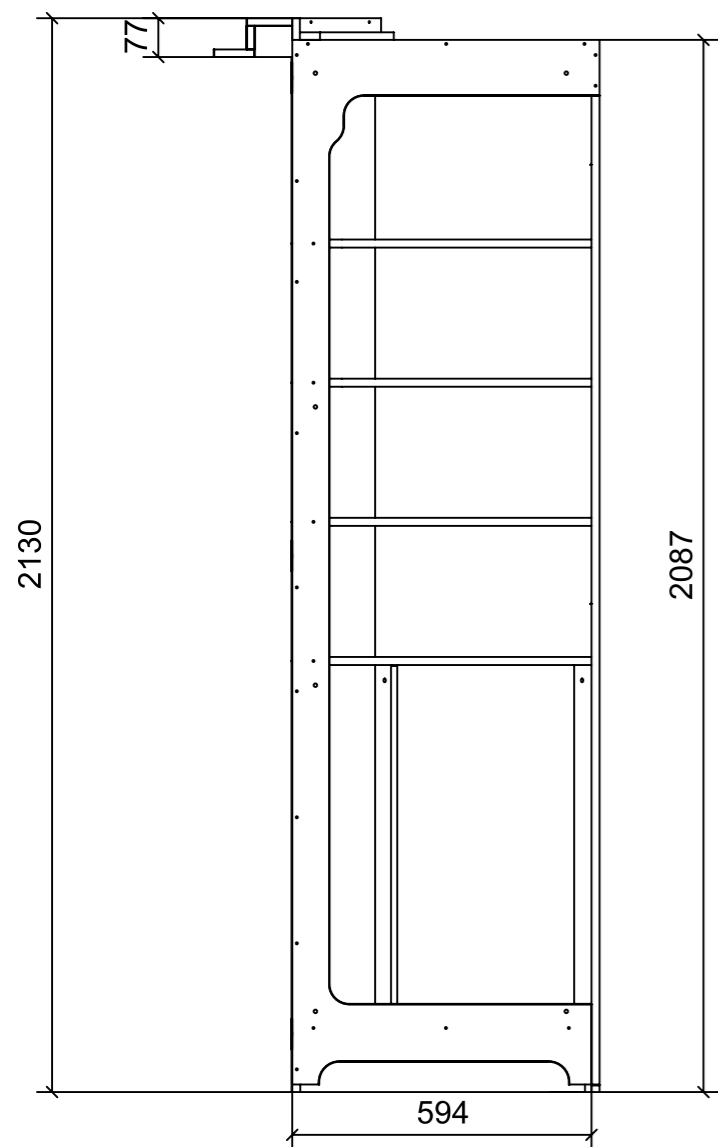

01

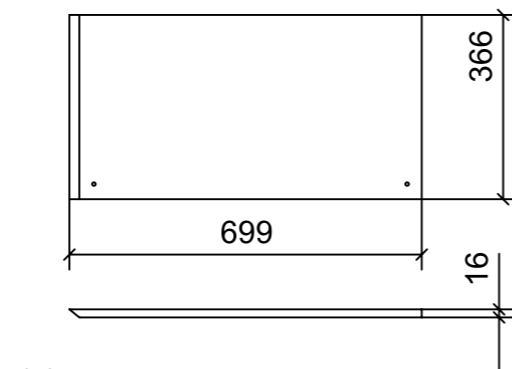

03

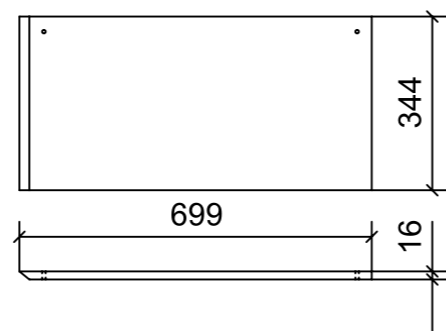

04

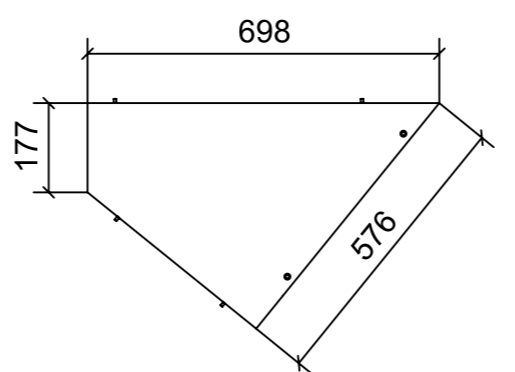

02

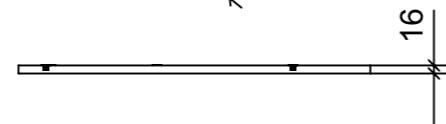

ELEMENTI DA MONTARE  
in MG\_CCF01  
e spedire con unico imballo

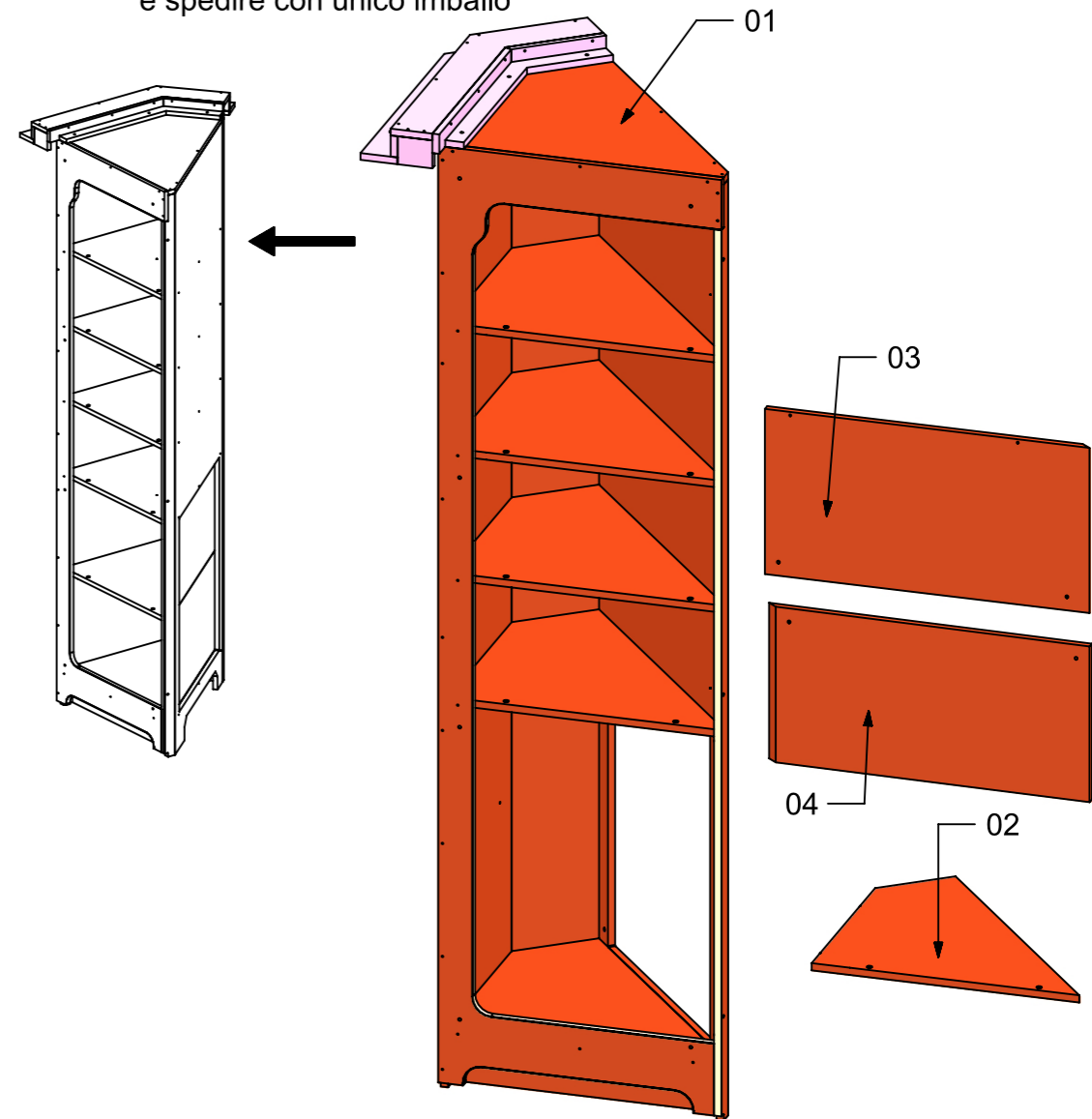

FERRAMENTA	QTY
PERNO LISCIO PER SPALLA_FBC BORGHI_1033PXX050531	4
GIUNTO REGGIRIPIANO CON BORDO ANTISGANCIO_FBC BORGHI_1033XXB060902	4
FITLOCK F_MASCHERPA_6020101102	17
BUSSOLA 6MA X 10 FORO DIAM.8	3

LOCALE	CODICE	DESCRIZIONE COMPONENTE	FINITURA	GR.
LOBBY MD	MD320_CCG01	OPT WINW COOLER	LAMINATO SMART 0180-2 JUNGLE	3

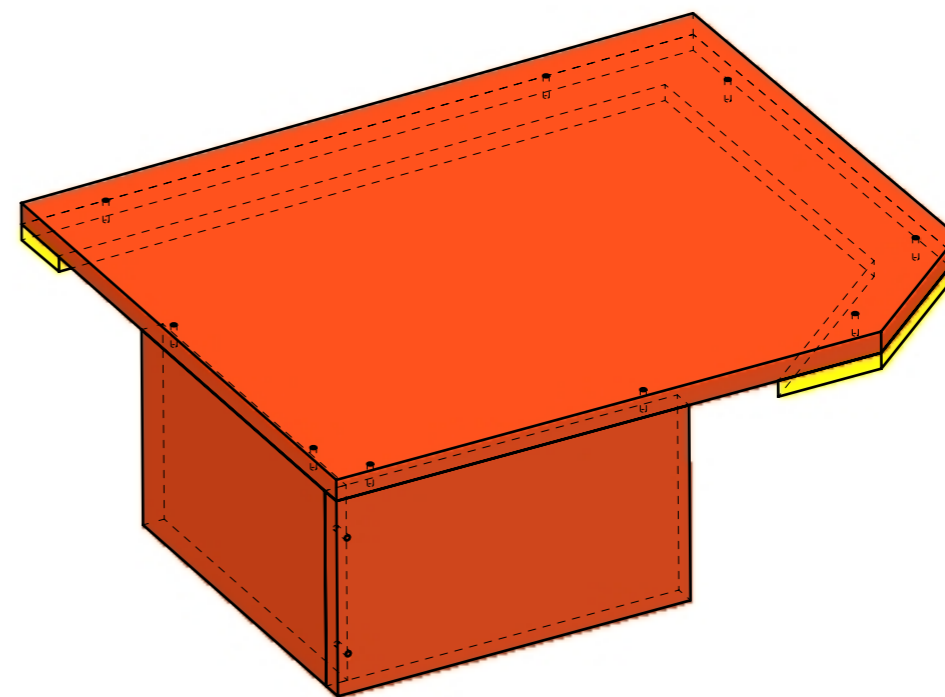
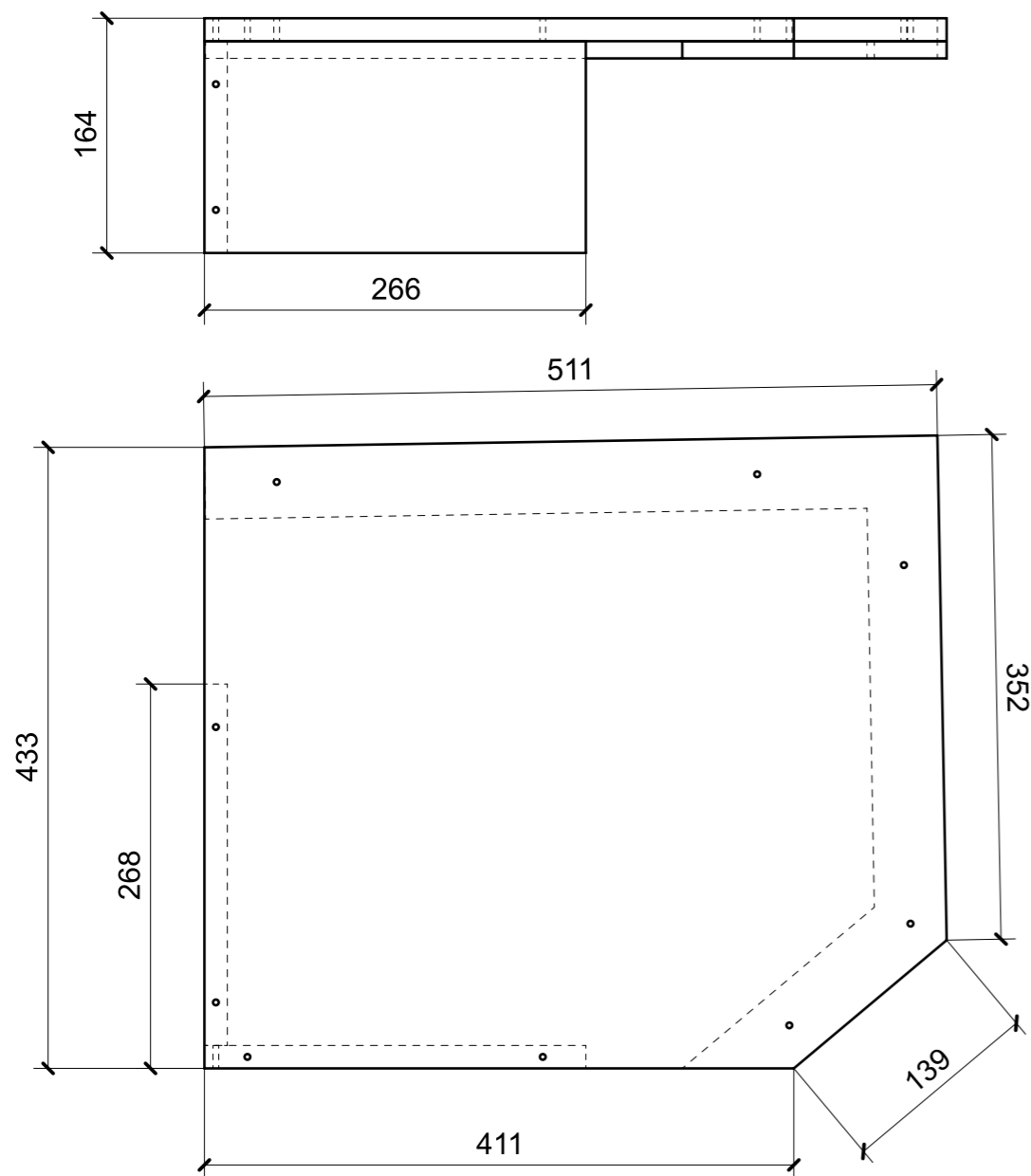

LOCALE	CODICE	DESCRIZIONE COMPONENTE	FINITURA	GR.
LOBBY MD	MD320_CCH01	GRADINO	GREZZO SPRUZZATO NERO	PTP

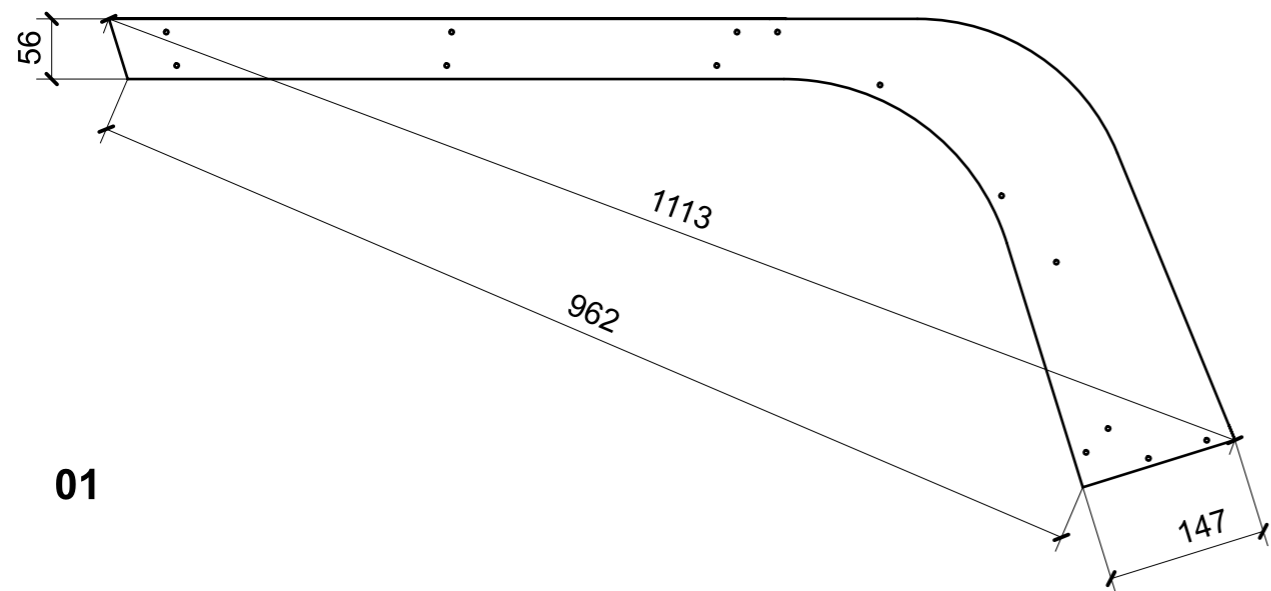
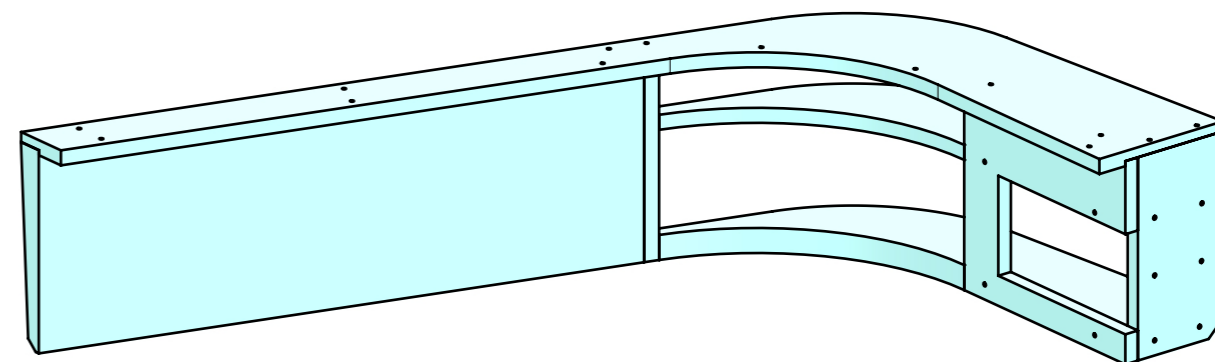
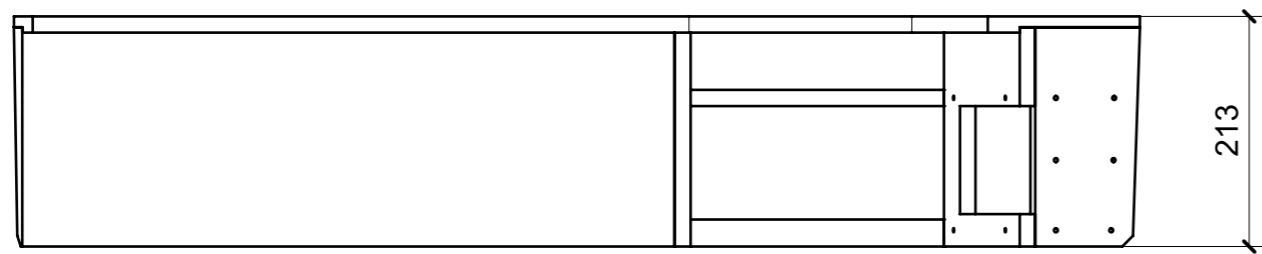

LOCALE	CODICE	DESCRIZIONE COMPONENTE	FINITURA	GR.
LOBBY MD	MD320_CCI01	CIELINO	CARTA MELAMINICA NERA	3

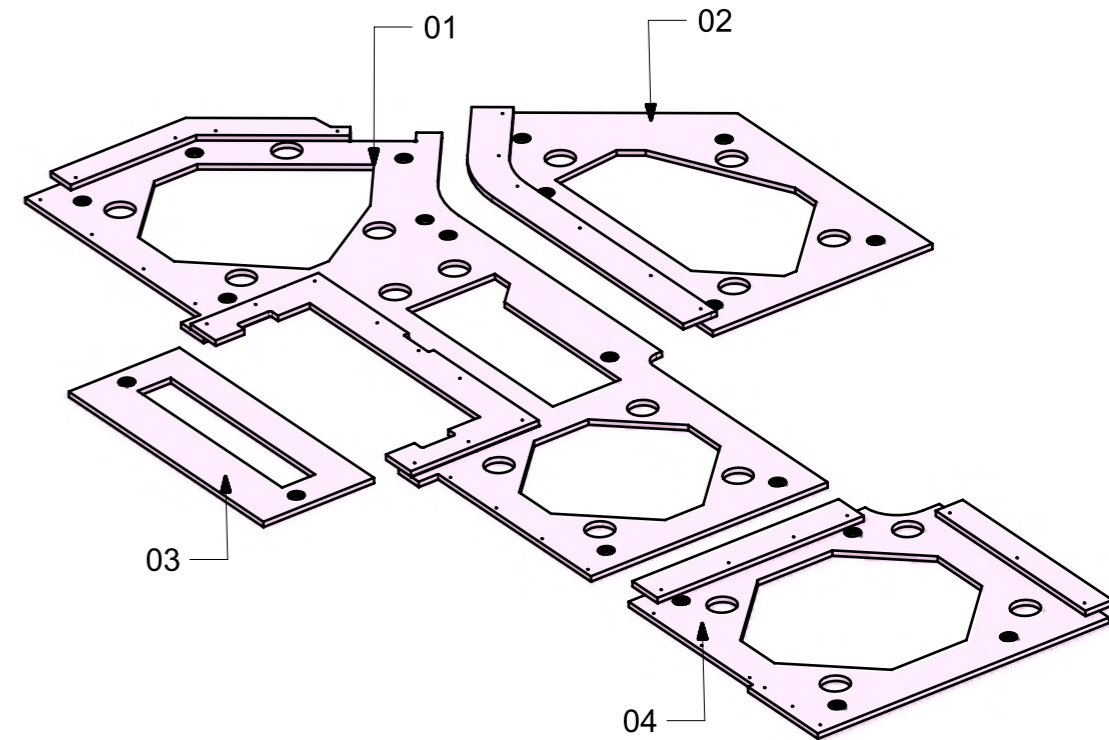
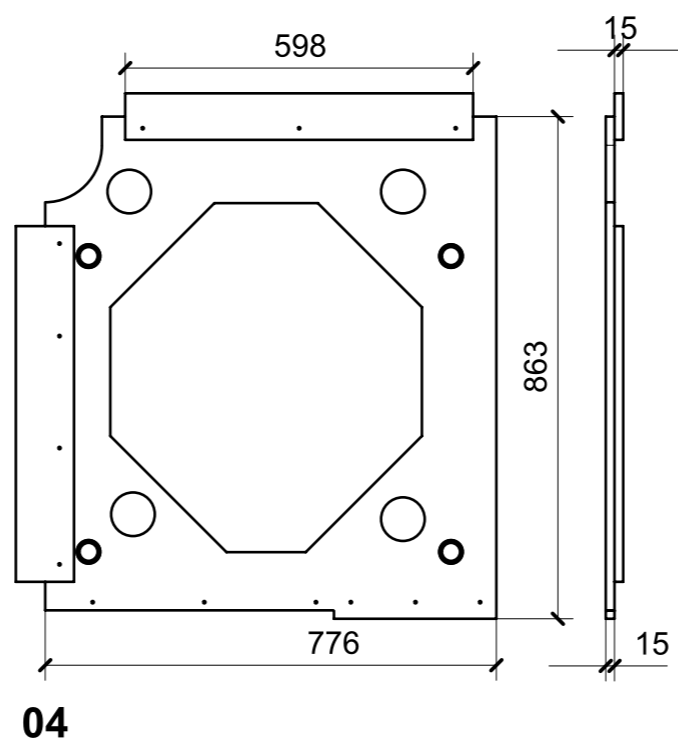
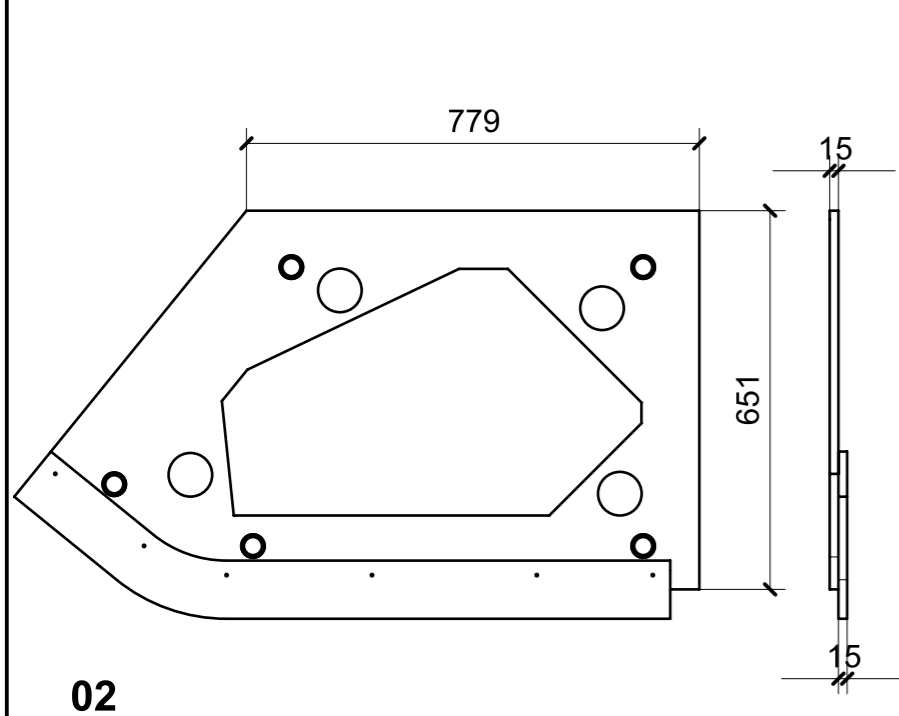
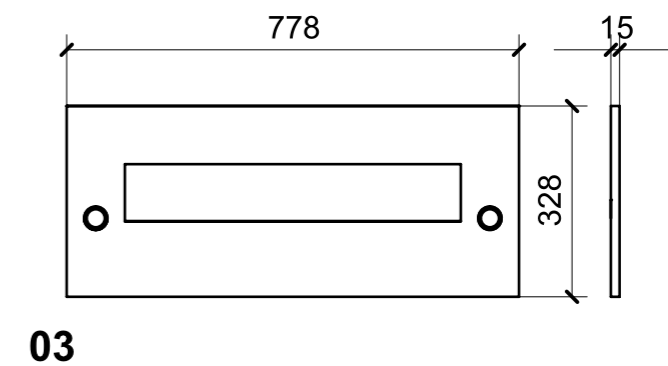
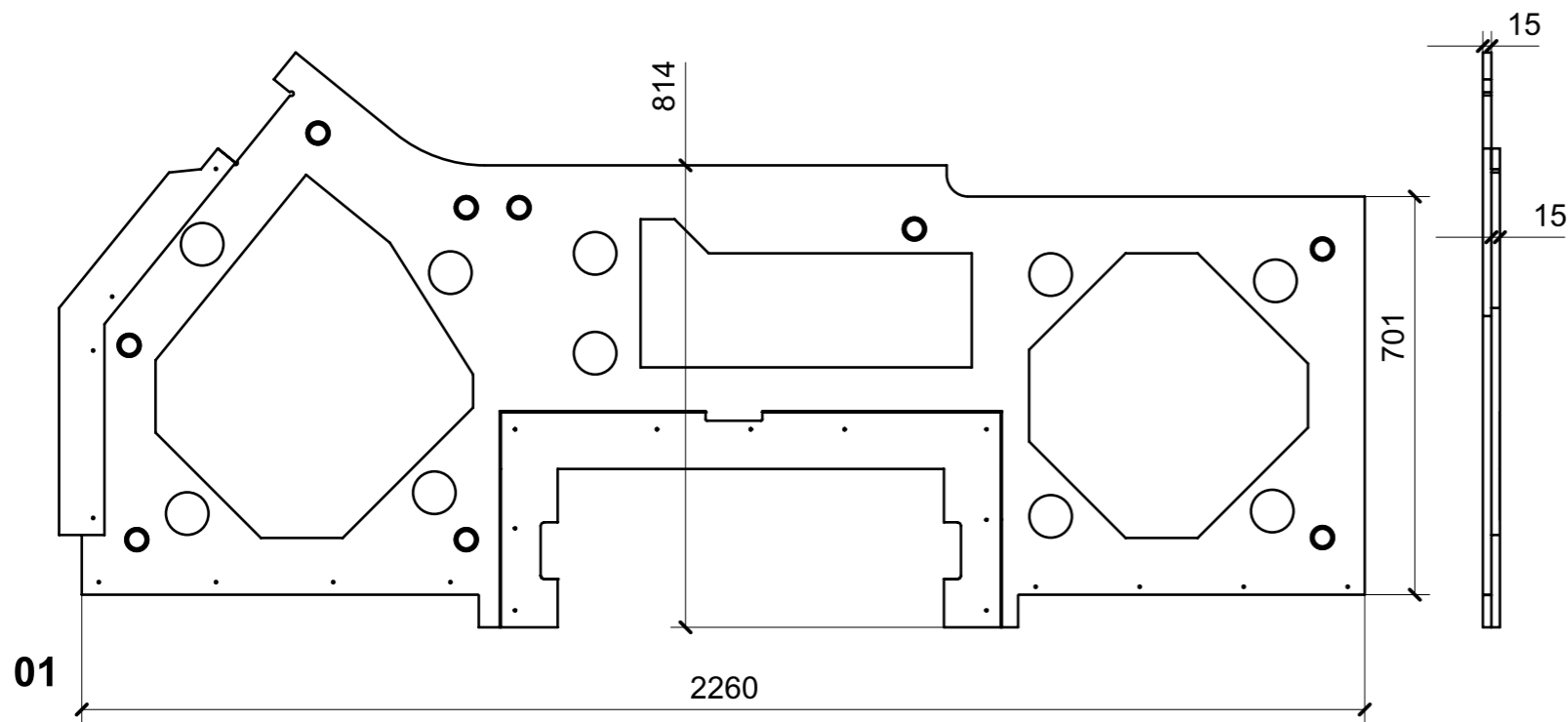

FERRAMENTA	QTY
FITLOCK F_MASCHERPA_6020101102	20

LOCALE	CODICE	DESCRIZIONE COMPONENTE	FINITURA	GR.
LOBBY MD	MD320_CCN01	STRUTTURA RIV. DI POPPA PORTA SCORREVOLE	LASTRA CHIARA	3

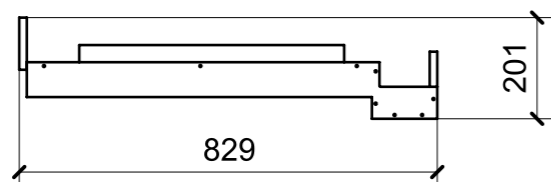
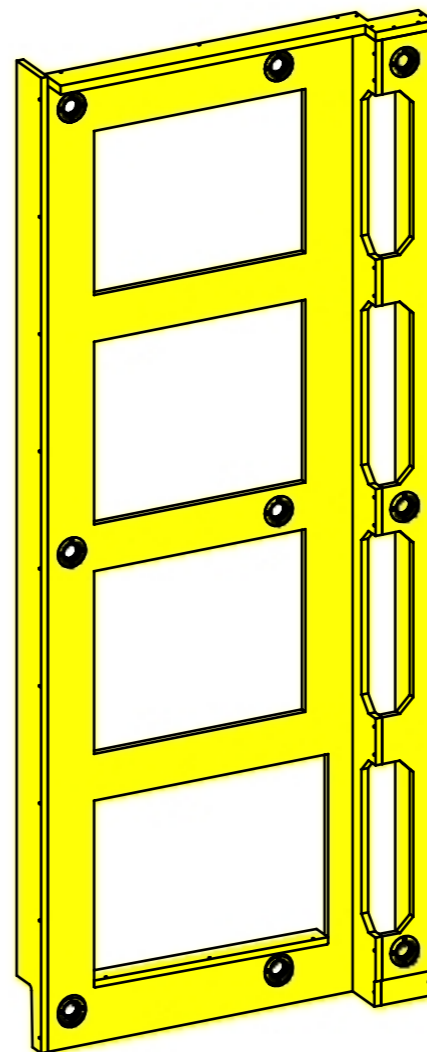
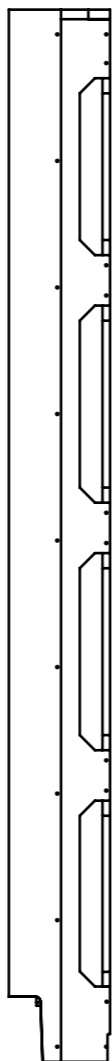
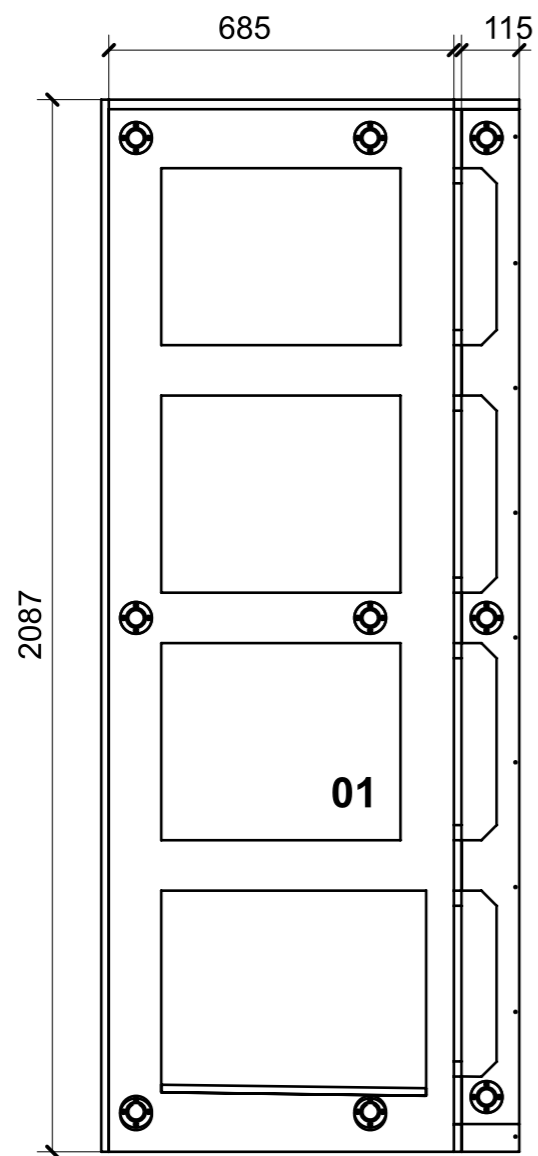

FERRAMENTA	QTY
BUSSOLA 6MA X 10 FORO DIAM.8	3
FITLOCK F_MASCHERPA_6020101102	9