

| LOCALE | CODICE | DESCRIZIONE COMPONENTE | FINITURA | GR. |
|--------|----------------|------------------------|---------------|-----|
| CUCINA | MD320_R02_KA01 | CASSA FRIGO POPPA | LASTRA CHIARA | 3 |

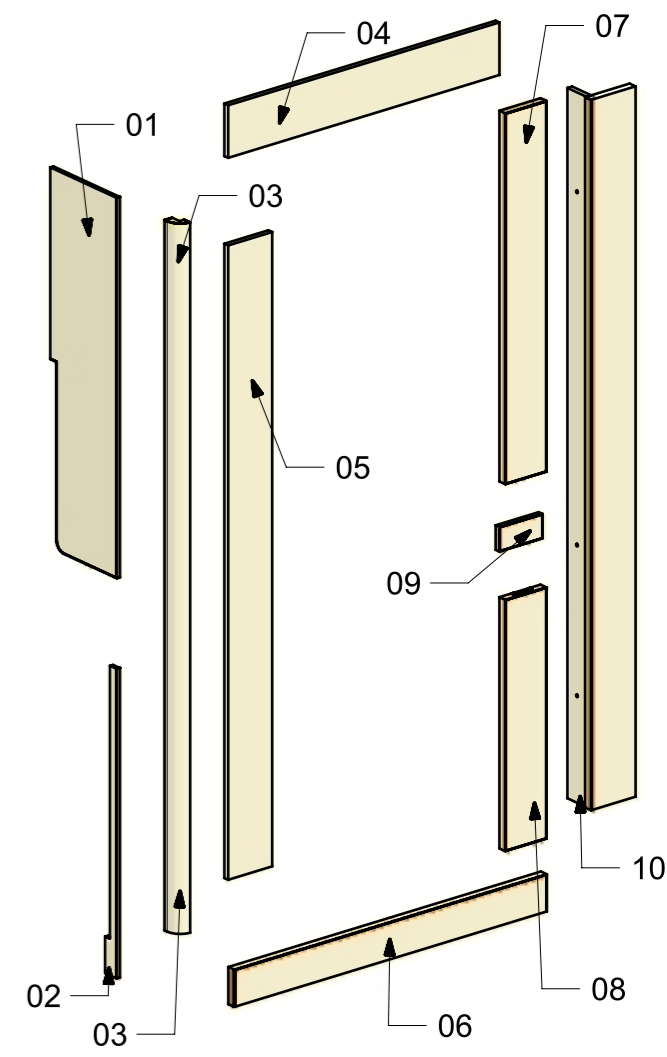
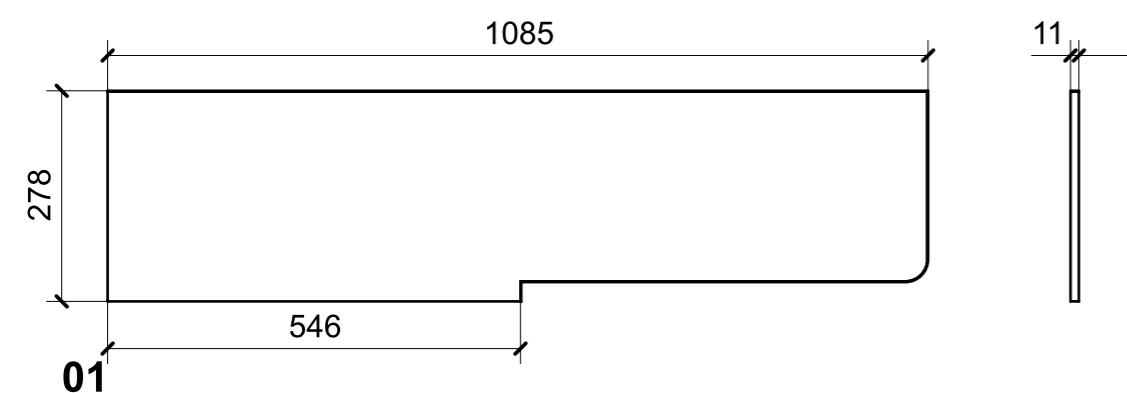
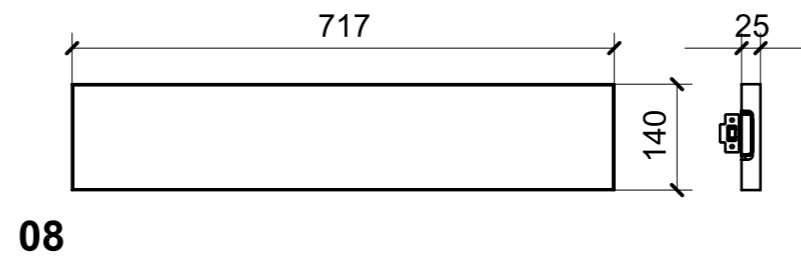
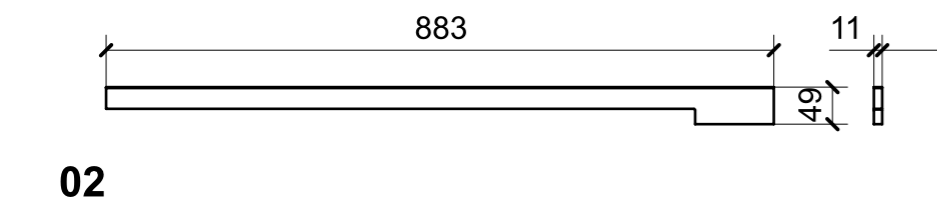
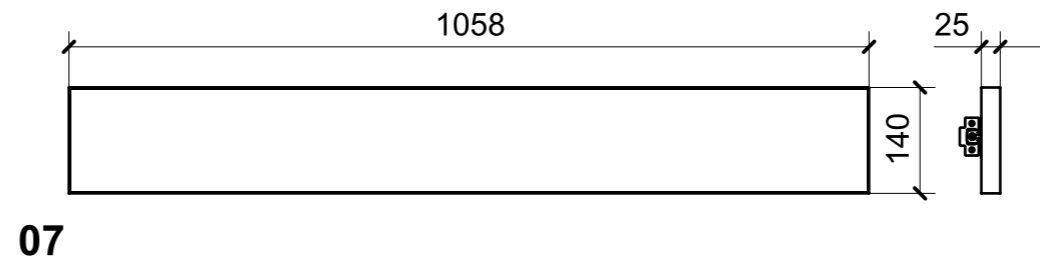
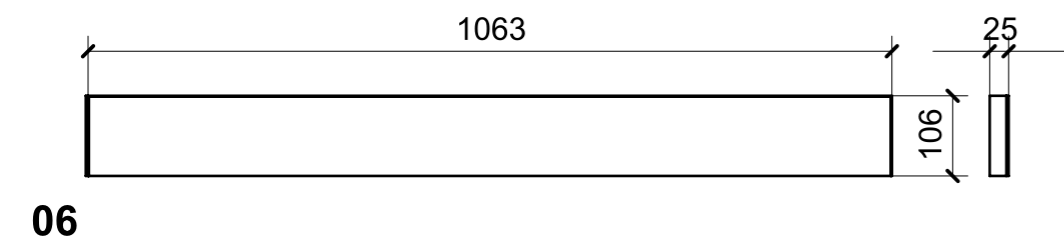
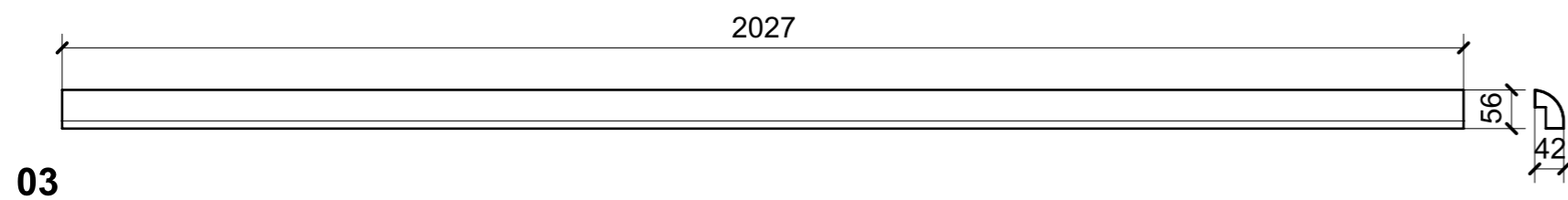
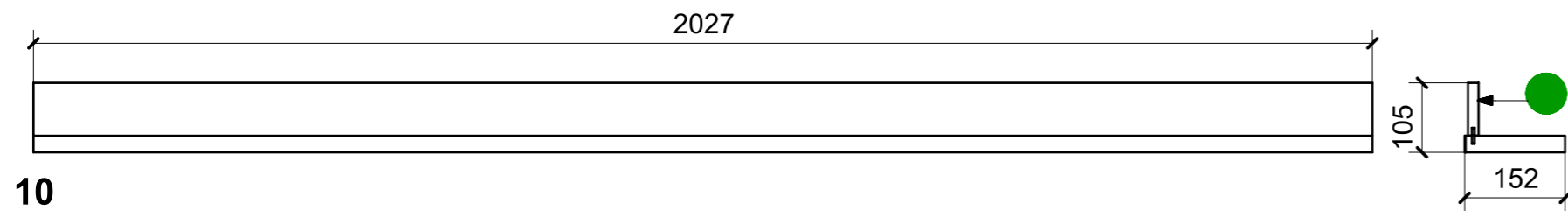
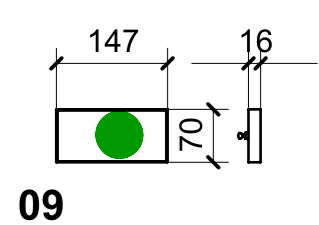
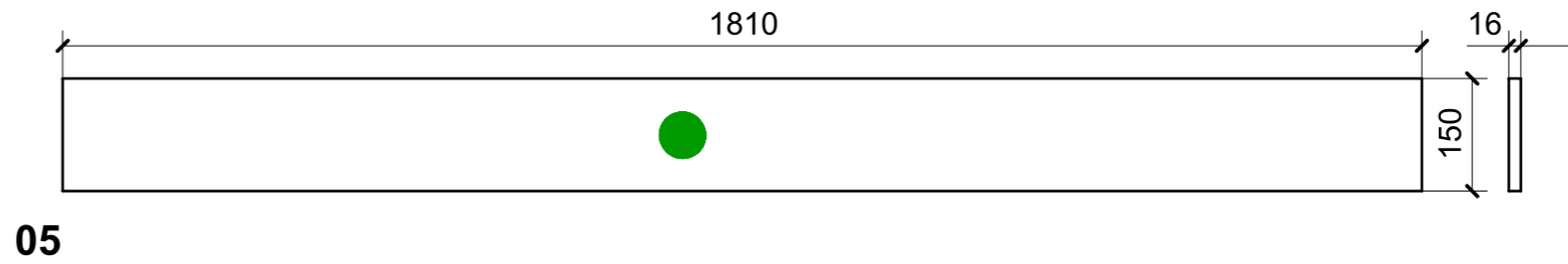
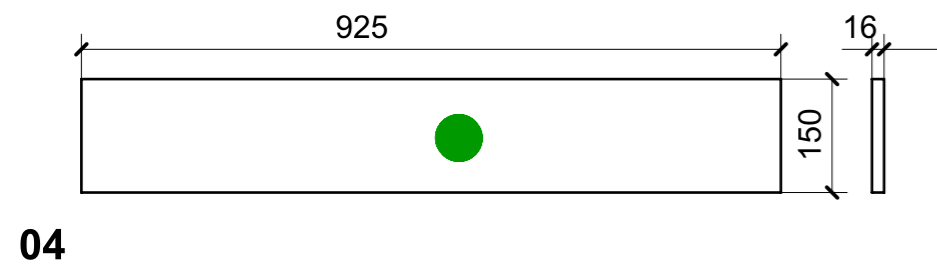

| FERRAMENTA | QTY |
|---------------------------------------|-----|
| MANIGLIA AD INCASSO_FORESTI_ART 238 C | 2 |
| MS INCASSO_ITALVIPLA_972_FMPC_M1B | 2 |

VERNICIATURA LASTRA/LACCATI:

● = VERNICIARE 1 LATO + FILI RASATI O BORDATI

NESSUN SIMBOLO = VERNICIARE 2 LATI + FILI RASATI O BORDATI

| LOCALE | CODICE | DESCRIZIONE COMPONENTE | FINITURA | GR. |
|--------|----------------|----------------------------------|---------------|-----|
| CUCINA | MD320_R02_KB01 | CASSA RICIRCOLO ARIA FRIGO POPPA | LASTRA CHIARA | 2 |

01

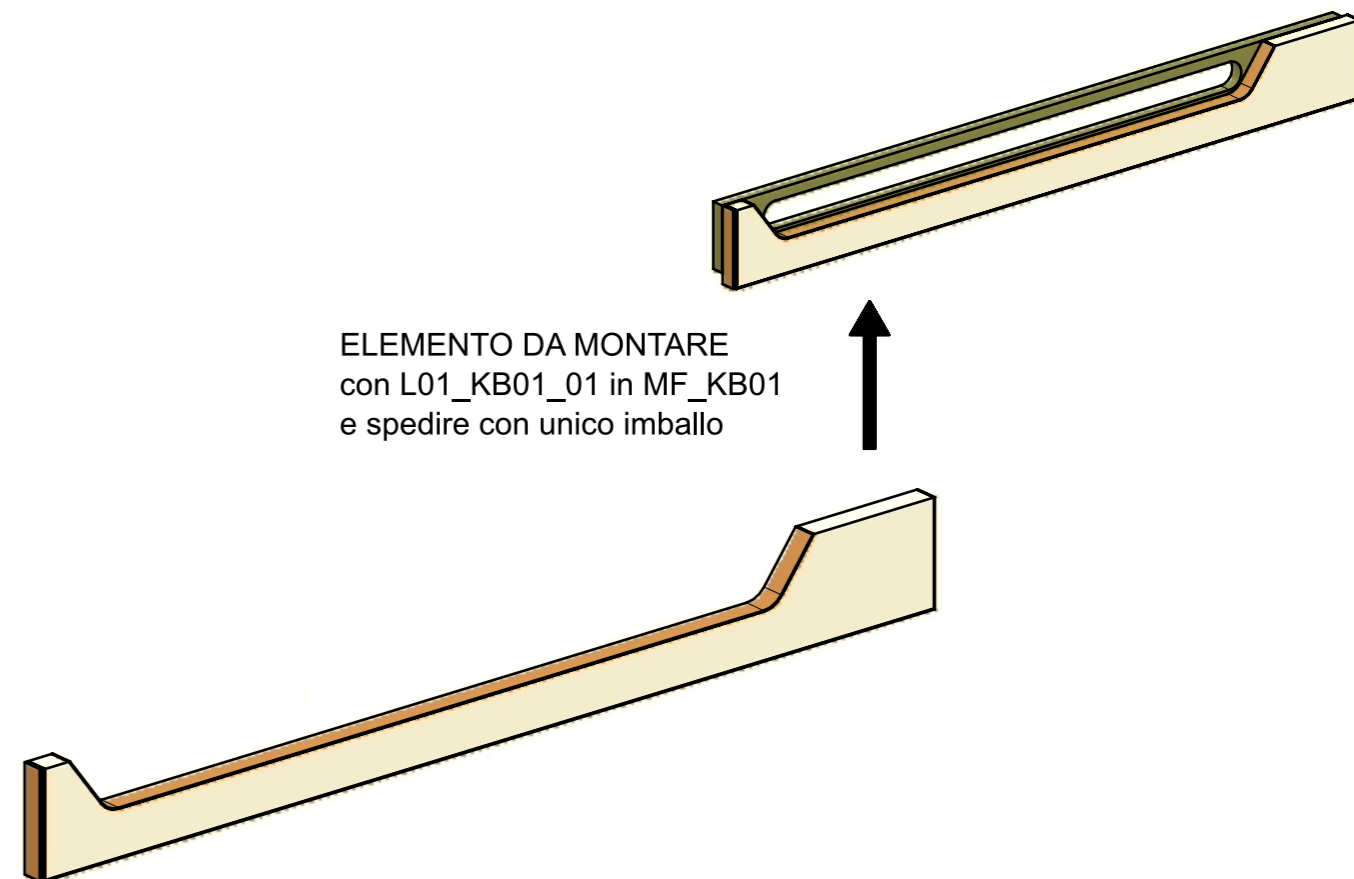
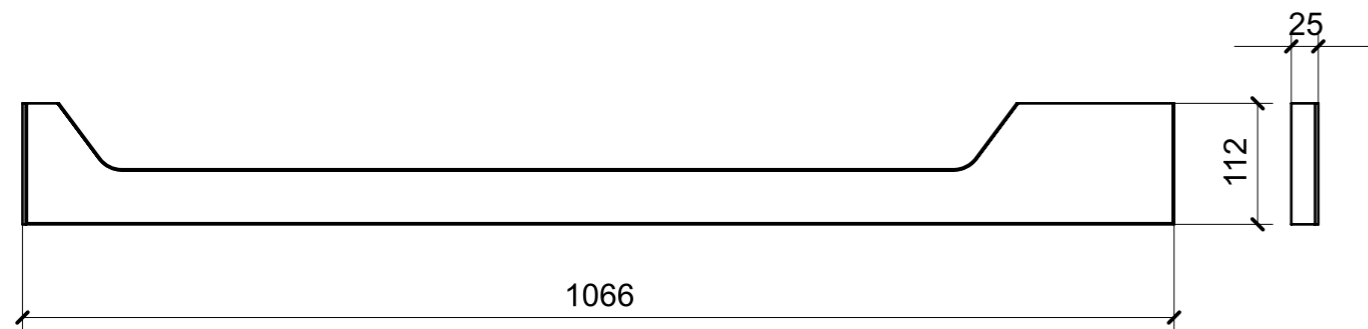

ELEMENTO DA MONTARE
con L01_KB01_01 in MF_KB01
e spedire con unico imballo

VERNICIATURA LASTRA/LACCATI:

● = VERNICIARE 1 LATO + FILI RASATI O BORDATI

NESSUN SIMBOLO = VERNICIARE 2 LATI + FILI RASATI O BORDATI

| LOCALE | CODICE | DESCRIZIONE COMPONENTE | FINITURA | GR. |
|--------|----------------|------------------------|---------------|-----|
| CUCINA | MD320_R02_KC01 | BASE CUCINA POPPA | LASTRA CHIARA | 4 |

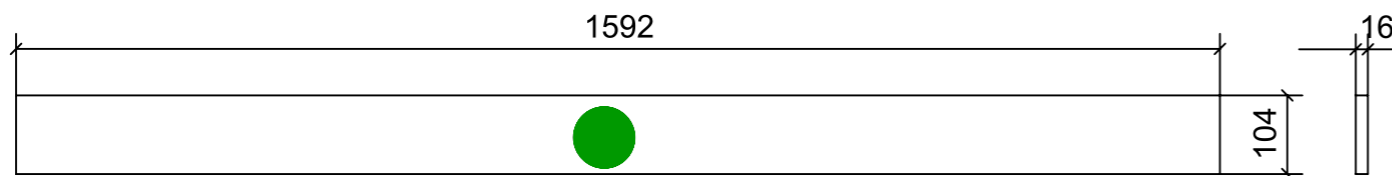

01

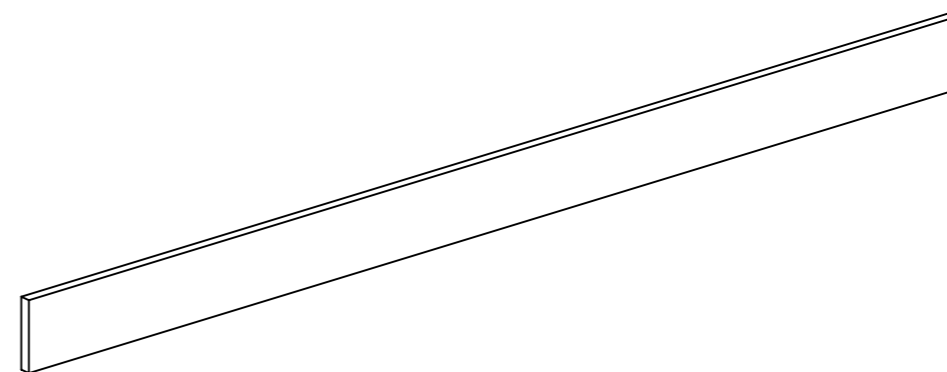

VERNICIATURA LASTRA/LACCATI:

● = VERNICIARE 1 LATO + FILI RASATI O BORDATI

NESSUN SIMBOLO = VERNICIARE 2 LATI + FILI RASATI O BORDATI

| LOCALE | CODICE | DESCRIZIONE COMPONENTE | FINITURA | GR. |
|--------|----------------|------------------------|---------------|-----|
| CUCINA | MD320_R02_KF01 | BASE CUCINA PRUA | LASTRA CHIARA | 4 |

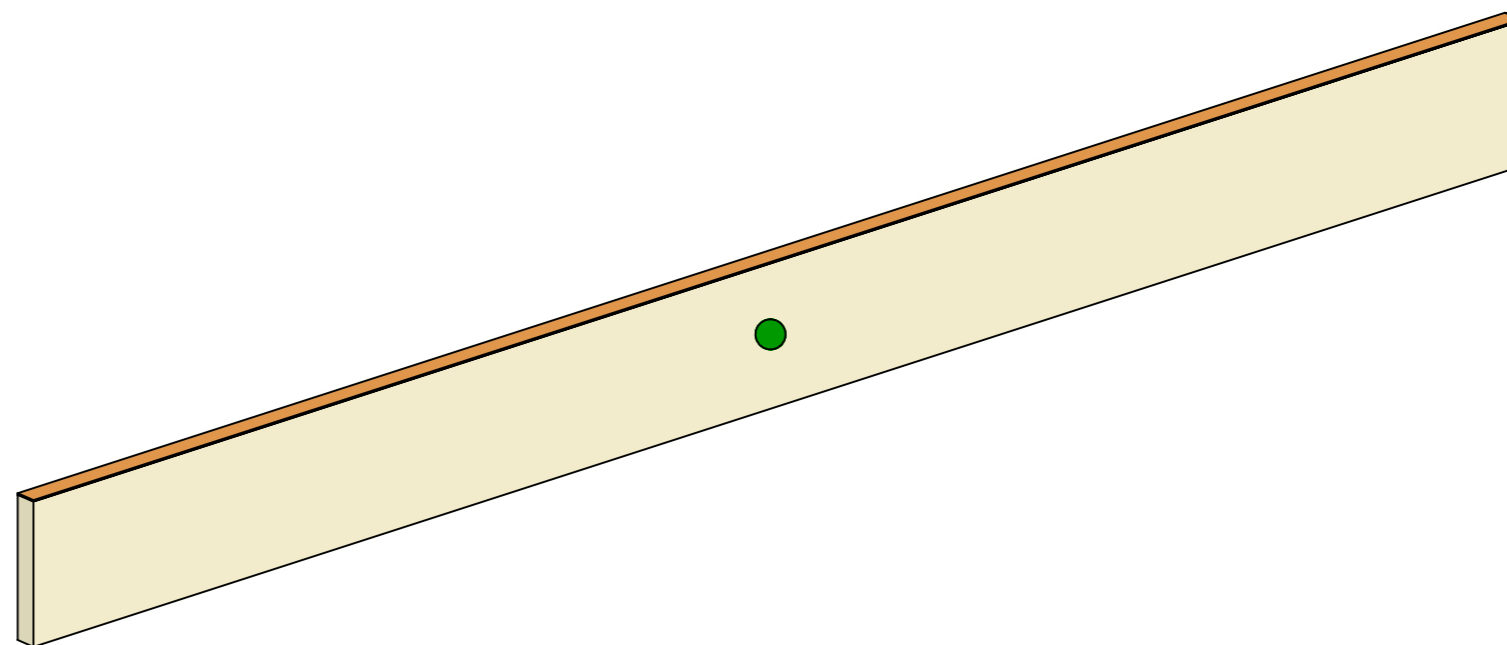
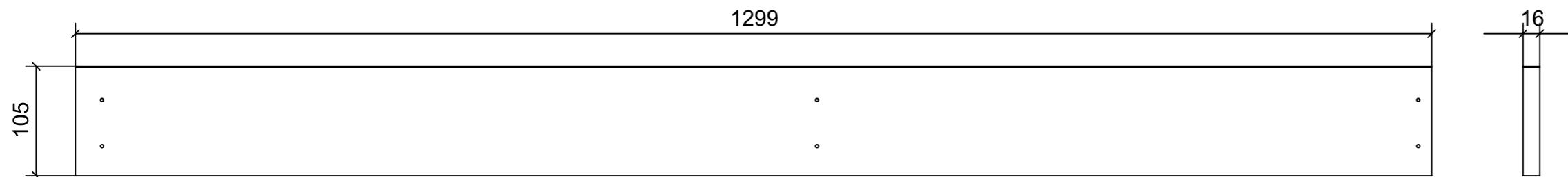

● = FILI RASATI

VERNICIATURA LASTRA/LACCATI:

● = VERNICIARE 1 LATO + FILI RASATI O BORDATI

NESSUN SIMBOLO = VERNICIARE 2 LATI + FILI RASATI O BORDATI

| LOCALE | CODICE | DESCRIZIONE COMPONENTE | FINITURA | GR. |
|--------|----------------|------------------------------------|---------------|-----|
| CUCINA | MD320_R02_KH01 | RIV.LATO SX BASE E PENSILE DI PRUA | LASTRA CHIARA | 2 |

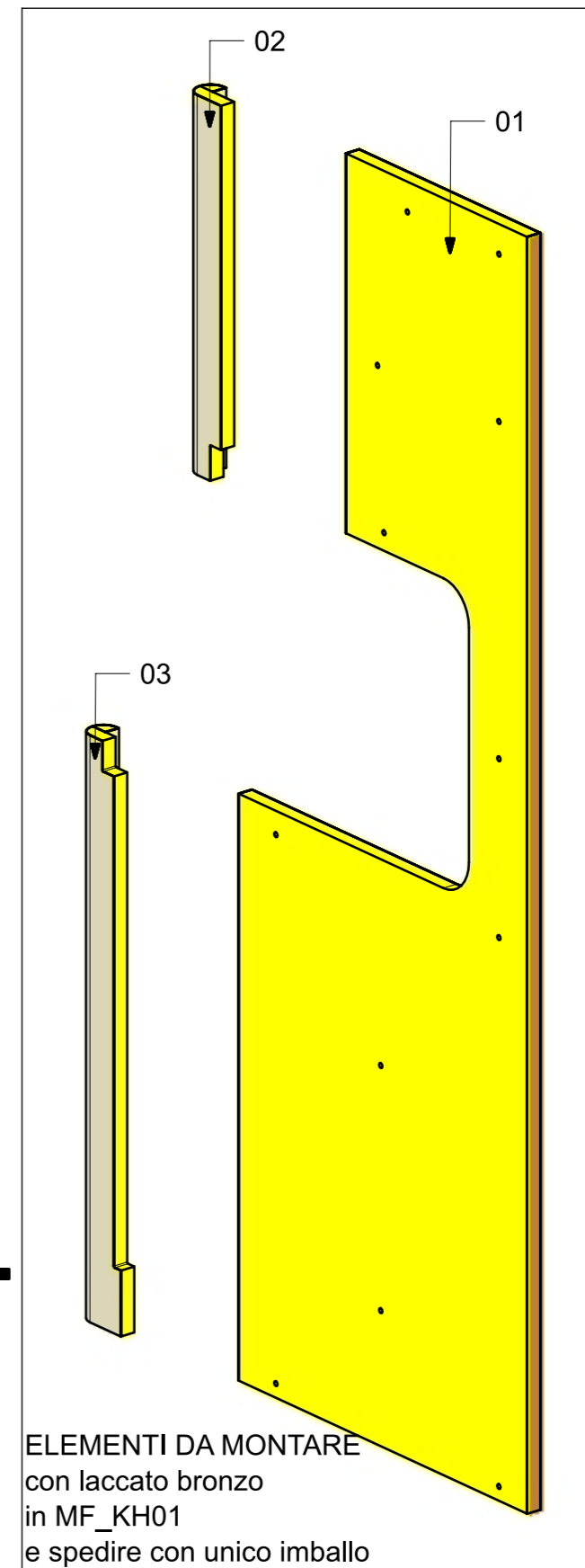
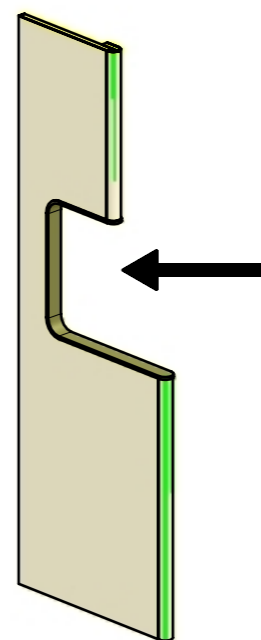
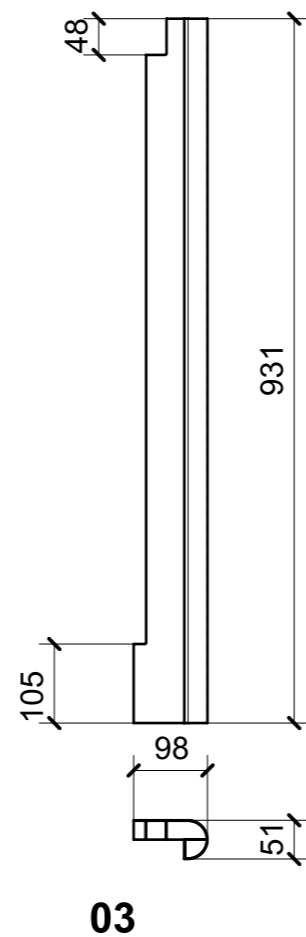
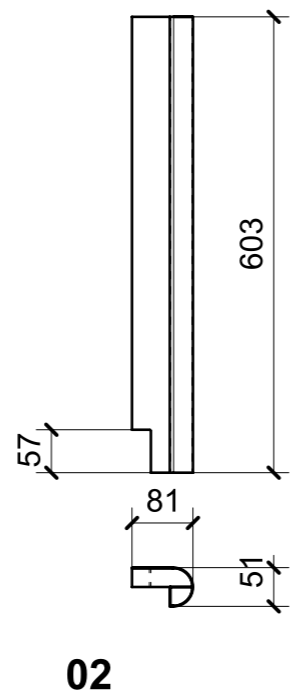
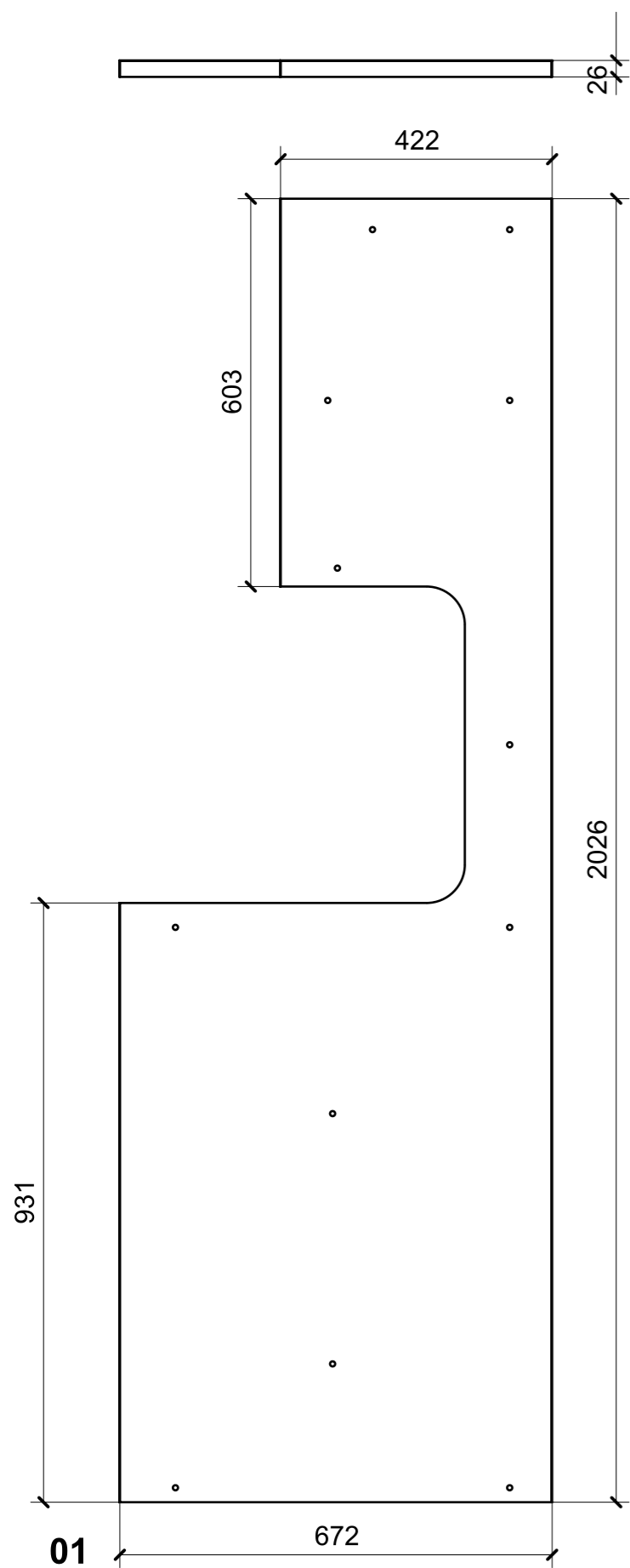

ELEMENTI DA MONTARE
 con laccato bronzo
 in MF_KH01
 e spedire con unico imballo

| LOCALE | CODICE | DESCRIZIONE COMPONENTE | FINITURA | GR. |
|--------|----------------|------------------------|--------------|-----|
| CUCINA | MD320_R01_KL01 | MOBILE PORTABICCHIERI | LASTRA SCURA | 4 |

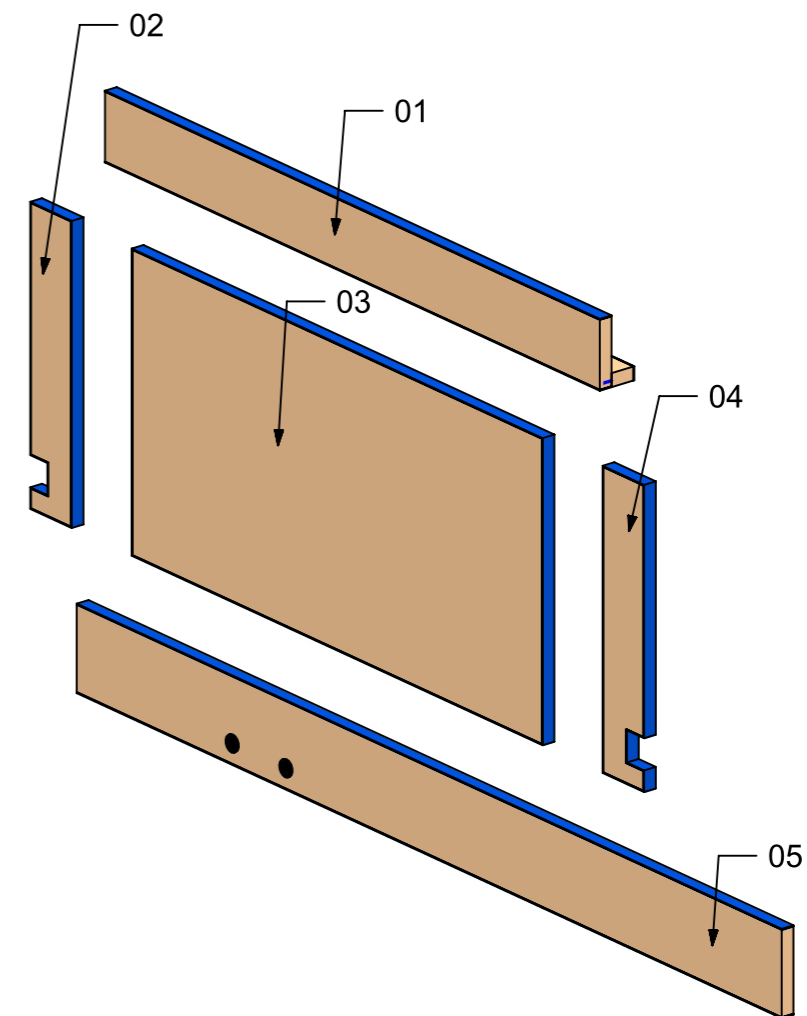
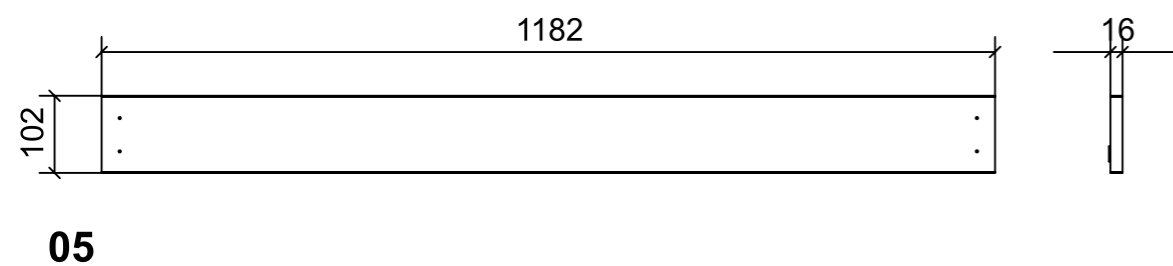
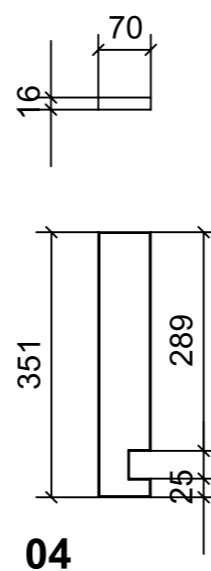
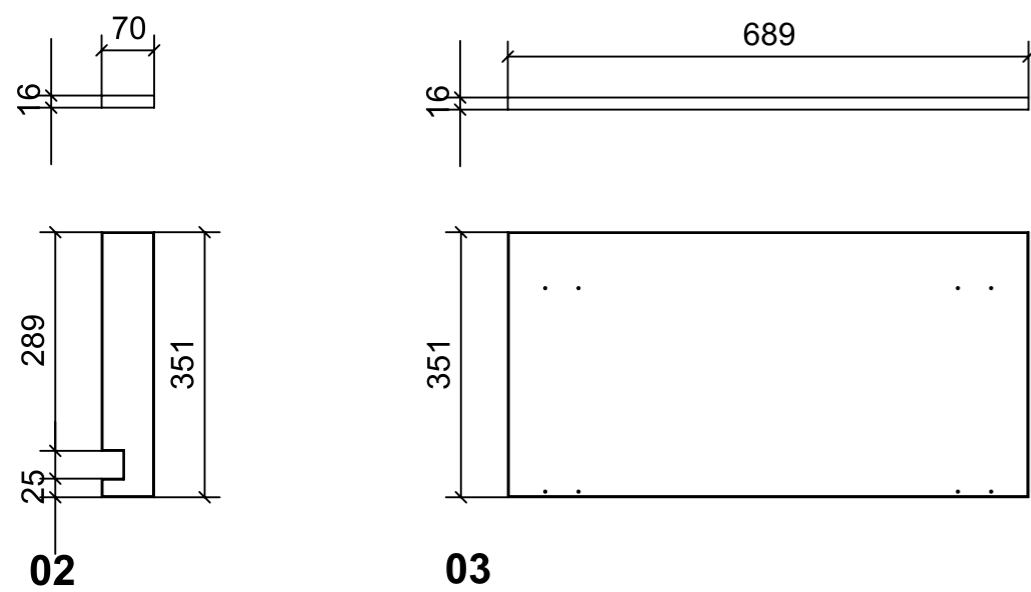
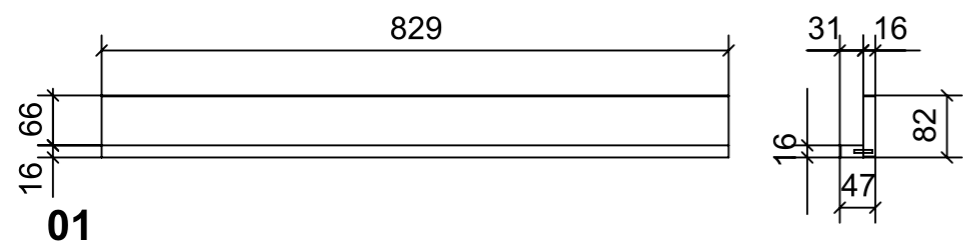

| FERRAMENTA | QTY |
|---------------------------------------|-----|
| RISCONTRO IN FERRO PER CALAMITA TONDO | 2 |

VERNICIATURA LASTRA/LACCATI:

● = FILI RASATI

● = VERNICIARE 1 LATO + FILI RASATI O BORDATI

NESSUN SIMBOLO = VERNICIARE 2 LATI + FILI RASATI O BORDATI

| | | | | |
|---------------|----------------|-------------------------------|-----------------|------------|
| LOCALE | CODICE | DESCRIZIONE COMPONENTE | FINITURA | GR. |
| CUCINA | MD320_R02_KL01 | MOBILE PORTABICCHIERI | LASTRA CHIARA | 4 |

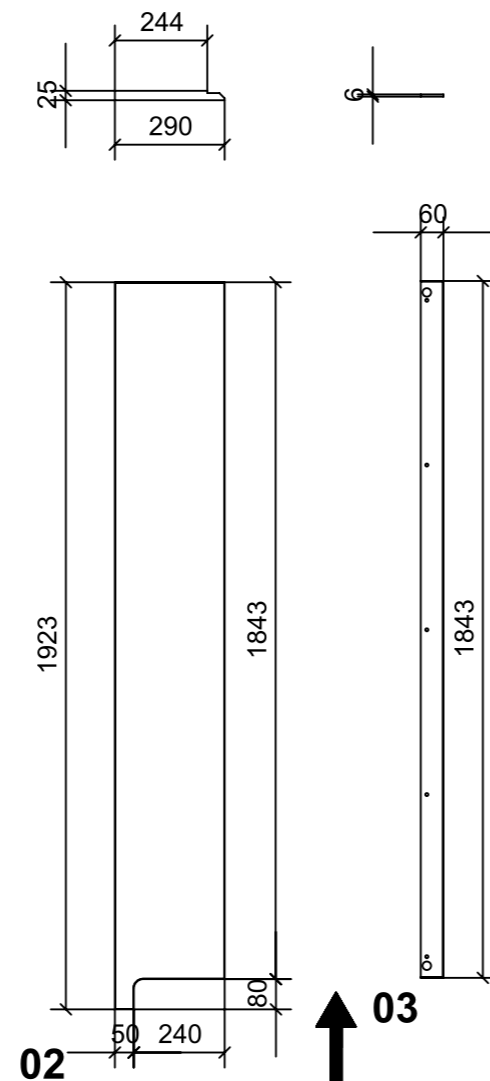
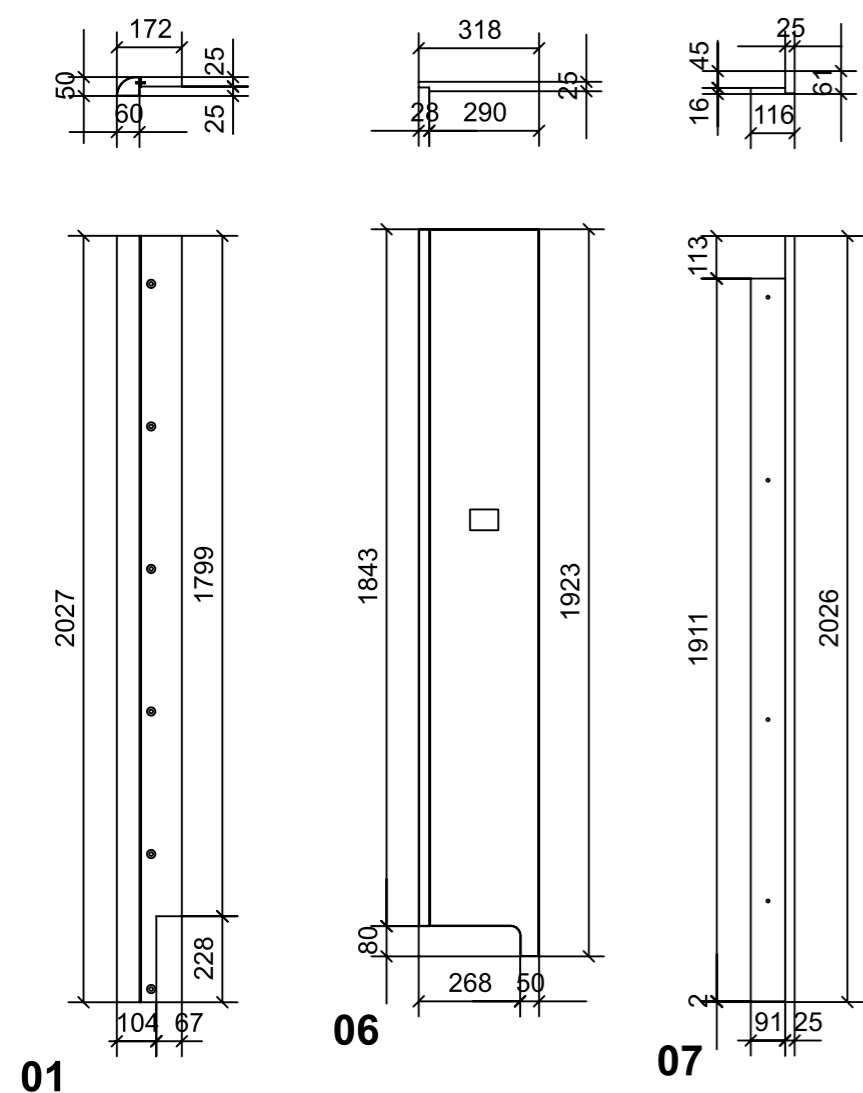

ELEMENTI DA MONTARE in MG_KL02 e spedire con unico imballo

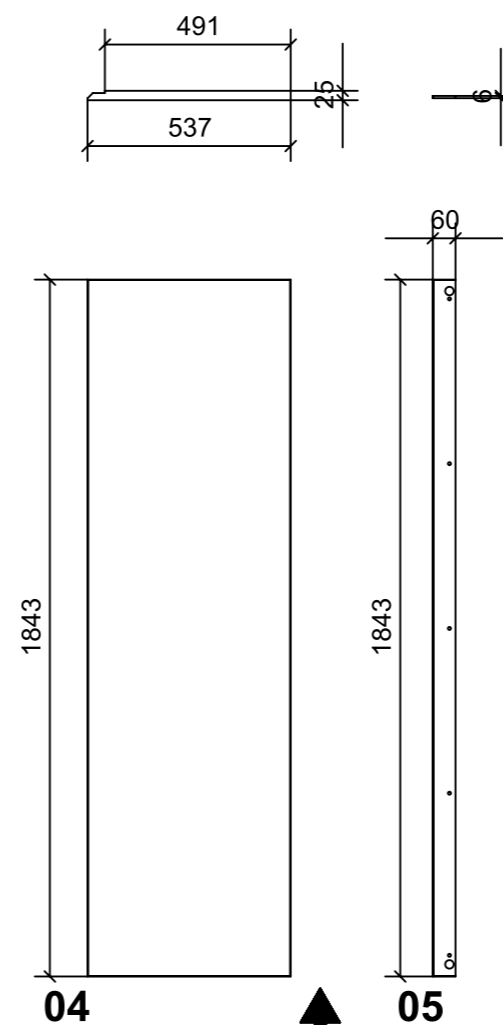
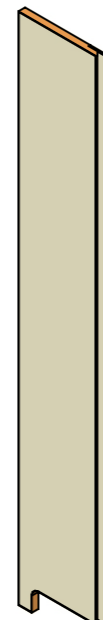

ELEMENTI DA MONTARE in MG_KL03 e spedire con unico imballo

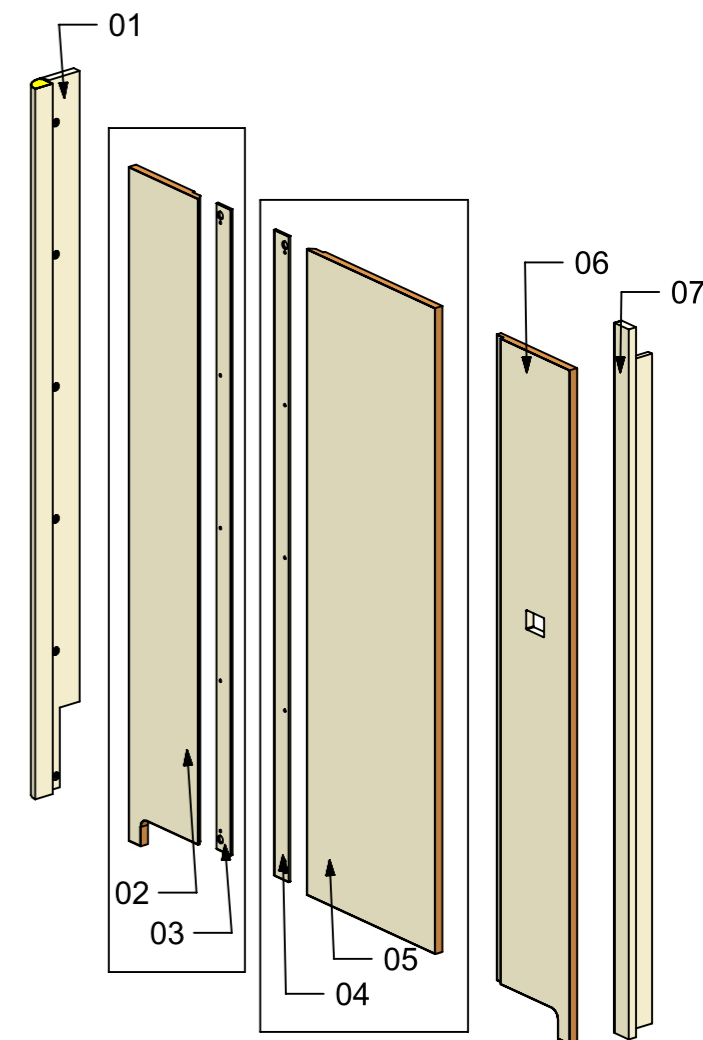
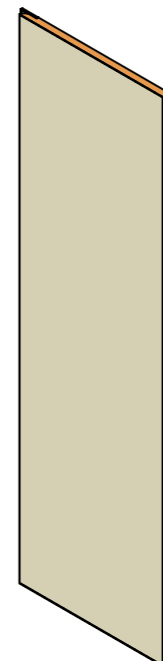

| FERRAMENTA | QTY |
|---|-----|
| MS INCASSO_ITALVIPLA_972_FMPC_M1B | 6 |
| BUSSOLA 6MA X 10 FORO DIAM.8 | 4 |
| BUSSOLA 5MA ANKOR BORGHI X CERNIERA PIANA | 16 |
| MAGNETE FORZA MAGNETICA1-5 10KG_HAFELE_246.87.112 | 4 |

VERNICIATURA LASTRA/LACCATI:

● = VERNICIARE 1 LATO + FILI RASATI O BORDATI

NESSUN SIMBOLO = VERNICIARE 2 LATI + FILI RASATI O BORDATI

| LOCALE | CODICE | DESCRIZIONE COMPONENTE | FINITURA | GR. |
|--------|----------------|-------------------------|---------------|-----|
| CUCINA | MD320_R02_KN01 | PLENUM MOBILE BICCHIERI | LASTRA CHIARA | PTP |

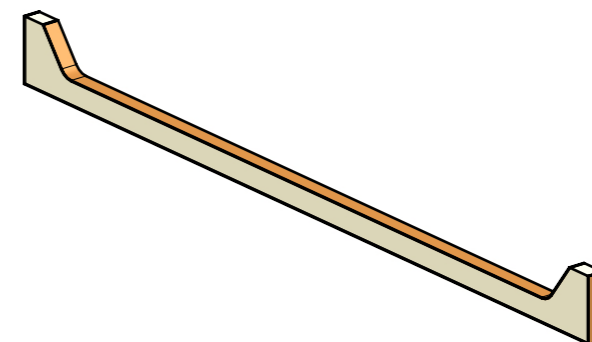
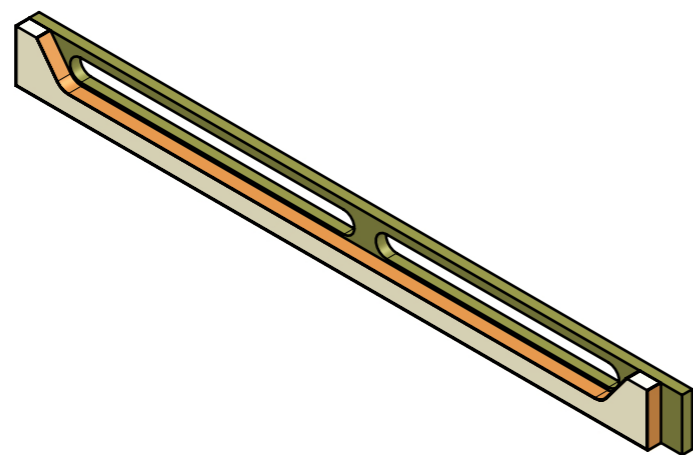

ELEMENTI DA MONTARE in MF_KN01
e spedire con unico imballo

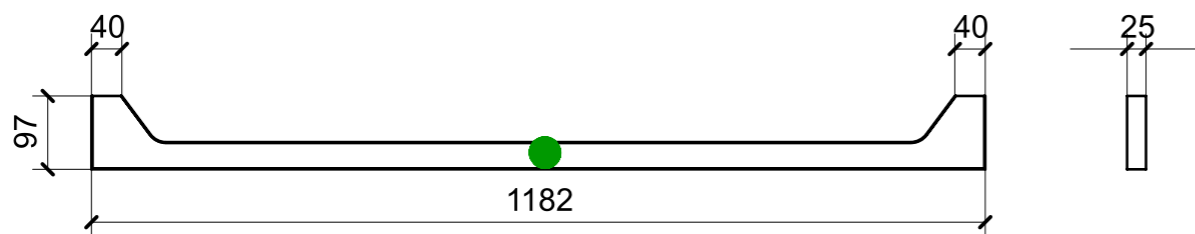

VERNICIATURA LASTRA/LACCATI:

● = FILI RASATI

● = VERNICIARE 1 LATO + FILI RASATI O BORDATI

NESSUN SIMBOLO = VERNICIARE 2 LATI + FILI RASATI O BORDATI

| LOCALE | CODICE | DESCRIZIONE COMPONENTE | FINITURA | GR. |
|--------|----------------|------------------------|--------------|-----|
| CUCINA | MD320_R01_KO01 | CASSA FRIGO AGGIUNTIVO | LASTRA SCURA | 4 |

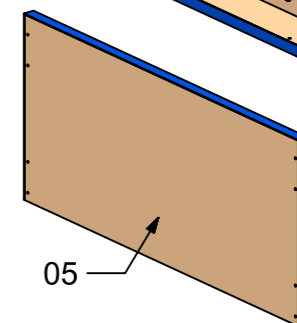
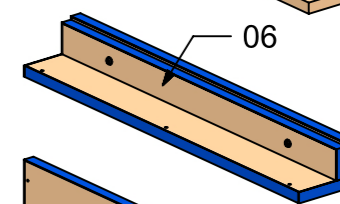
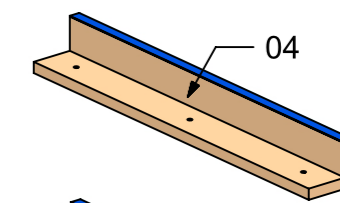
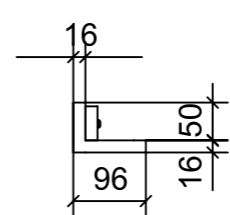
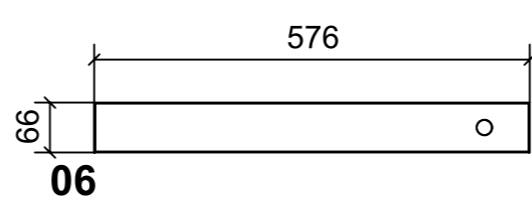
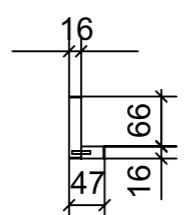
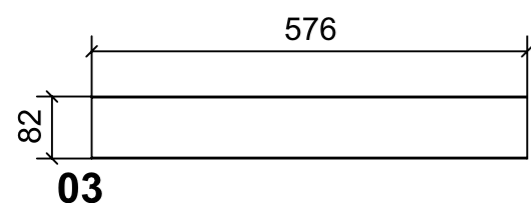
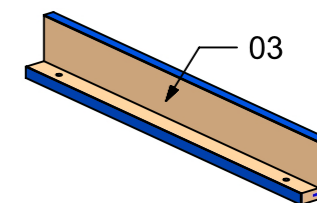
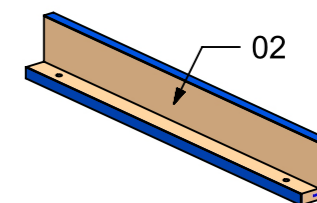
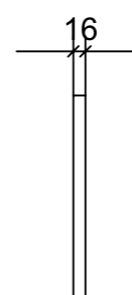
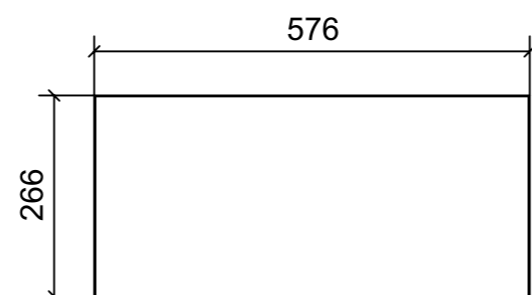
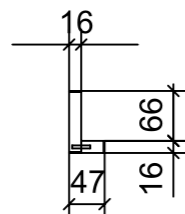
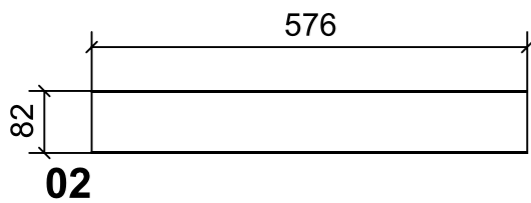
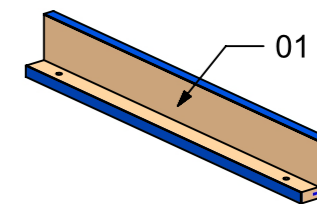
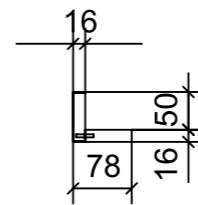
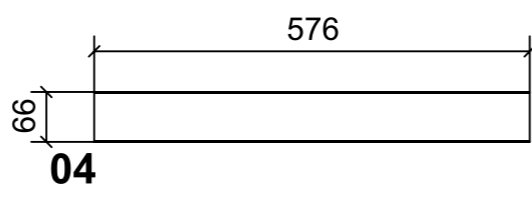
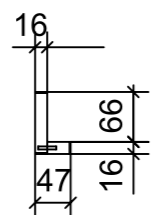
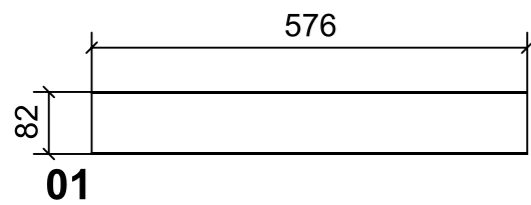

| FERRAMENTA | QTY |
|---|-----|
| RISCONTRO IN FERRO PER CALAMITA TONDO | 1 |
| VITE 6MA X 25 TESTA BOMBATA NERA BHCS 10.9 ISO 7380 | 2 |

VERNICIATURA LASTRA/LACCATI:

● = VERNICIARE 1 LATO + FILI RASATI O BORDATI

NESSUN SIMBOLO = VERNICIARE 2 LATI + FILI RASATI O BORDATI

| | | | | |
|---------------|----------------|-------------------------------|-----------------|------------|
| LOCALE | CODICE | DESCRIZIONE COMPONENTE | FINITURA | GR. |
| CUCINA | MD320_R02_KO01 | CASSA FRIGO AGGIUNTIVO | LASTRA CHIARA | 4 |

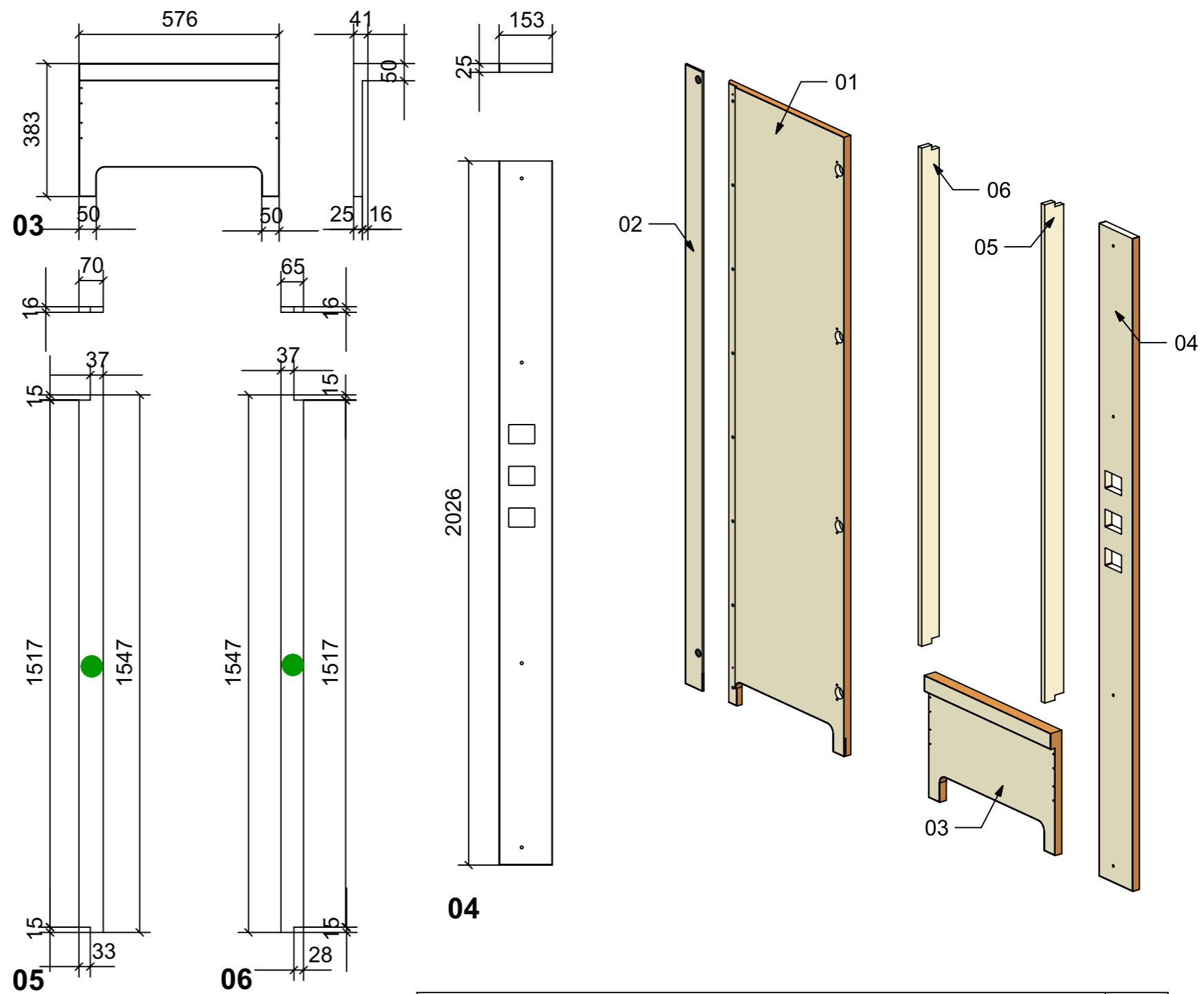
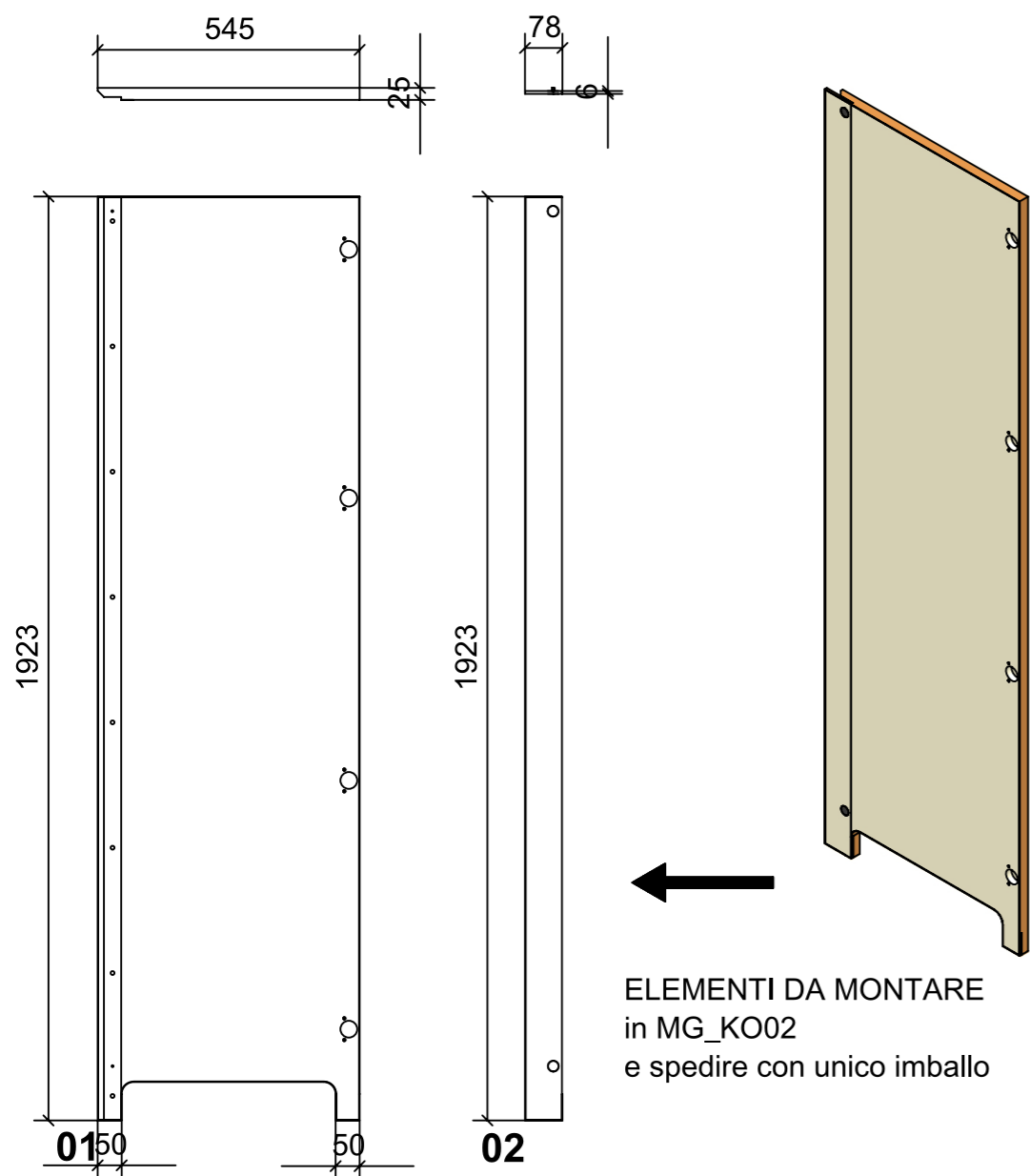

| FERRAMENTA | QTY |
|---|-----|
| BUSSOLA 5MA ANKOR BORGHINI X CERNIERA COLLO PIENO | 8 |
| MAGNETE FORZA MAGNETICA1-5 10KG_HAFELE_246.87.112 | 2 |

VERNICIATURA LASTRA/LACCATI:

● = VERNICIARE 1 LATO + FILI RASATI O BORDATI

NESSUN SIMBOLO = VERNICIARE 2 LATI + FILI RASATI O BORDATI

| LOCALE | CODICE | DESCRIZIONE COMPONENTE | FINITURA | GR. |
|--------|----------------|-------------------------------------|---------------|-----|
| CUCINA | MD320_R02_KP01 | CASSA RICIRCOLO ARIA FRIGO AGGIUNTO | LASTRA CHIARA | PTP |

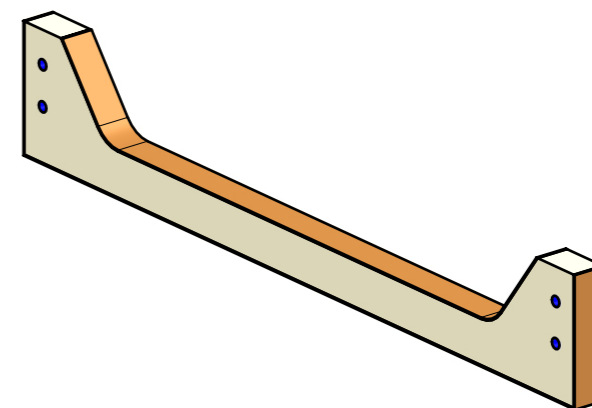
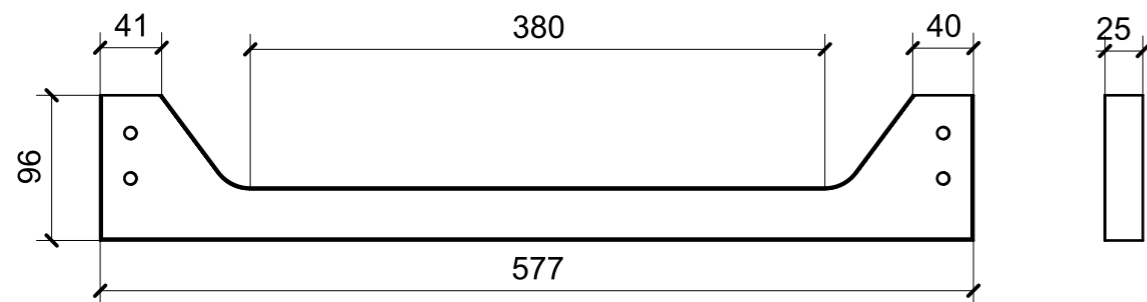

ELEMENTO DA MONTARE in MF_KP01
e spedire con unico imballo

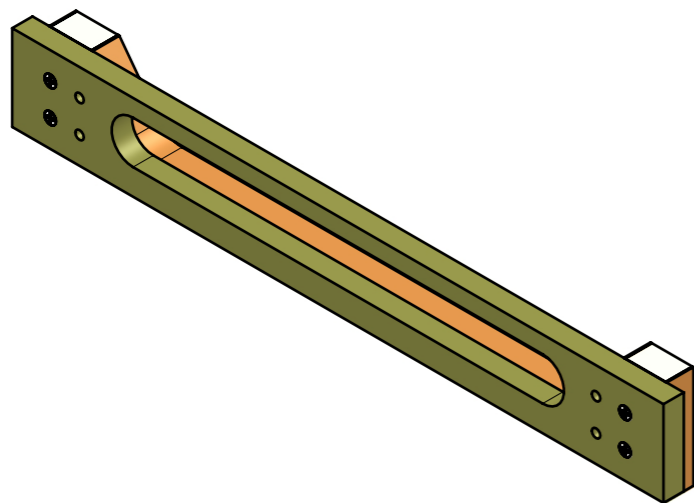

| FERRAMENTA | QTY |
|------------------------------|-----|
| BUSSOLA 6MA X 10 FORO DIAM.8 | 4 |
| VITE 6MA X 25 TESTA SVASATA | 4 |

VERNICIATURA LASTRA/LACCATI:

● = FILI RASATI

● = VERNICIARE 1 LATO + FILI RASATI O BORDATI

NESSUN SIMBOLO = VERNICIARE 2 LATI + FILI RASATI O BORDATI

| LOCALE | CODICE | DESCRIZIONE COMPONENTE | FINITURA | GR. |
|--------|----------------|-----------------------------------|---------------|-----|
| CUCINA | MD320_R02_KS01 | RIV. LATO DX BASE PENSILE DI PRUA | LASTRA CHIARA | 2 |

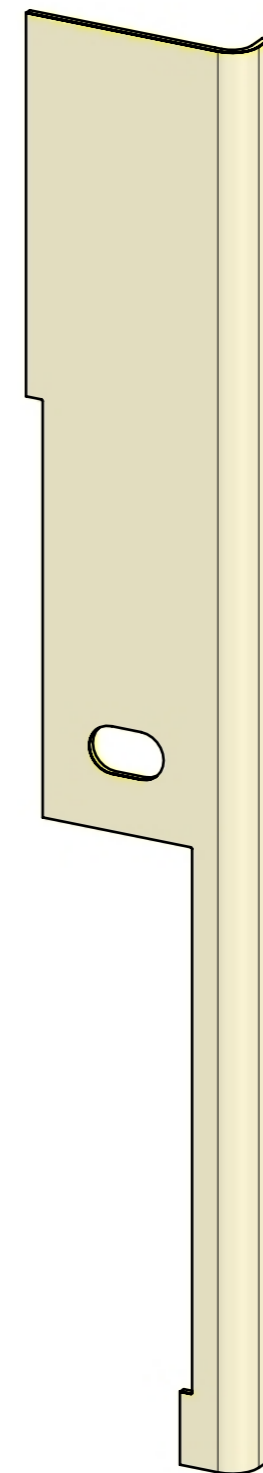
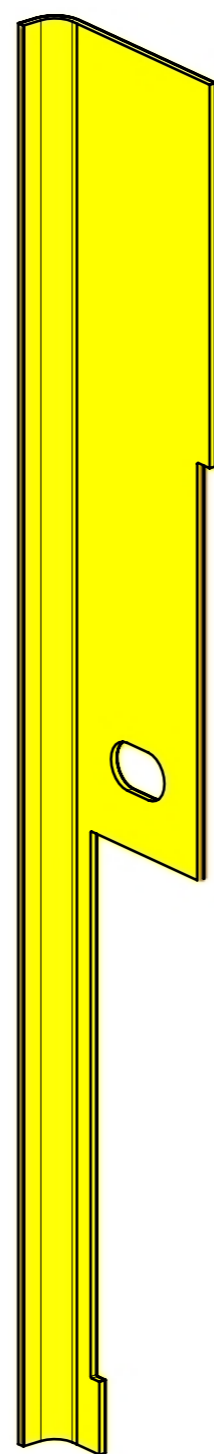
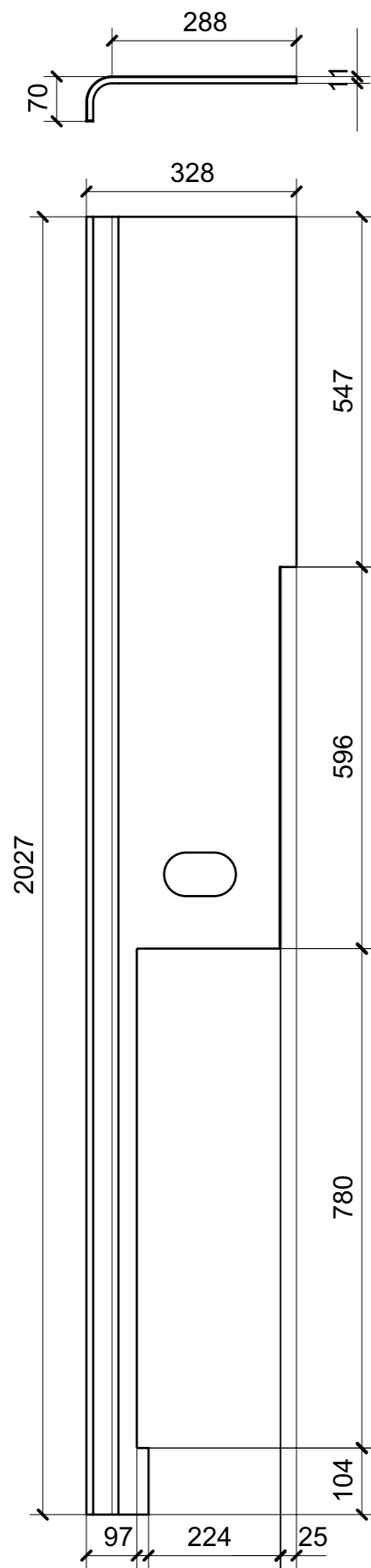

VERNICIATURA LASTRA/LACCATI:

● = VERNICIARE 1 LATO + FILI RASATI O BORDATI

NESSUN SIMBOLO = VERNICIARE 2 LATI + FILI RASATI O BORDATI

| LOCALE | CODICE | DESCRIZIONE COMPONENTE | FINITURA | GR. |
|--------|----------------|--|---------------|-----|
| CUCINA | MD320_R02_KT01 | RIV. PARATIA PORTA SCORR. DAILY TOILET | LASTRA CHIARA | PTP |

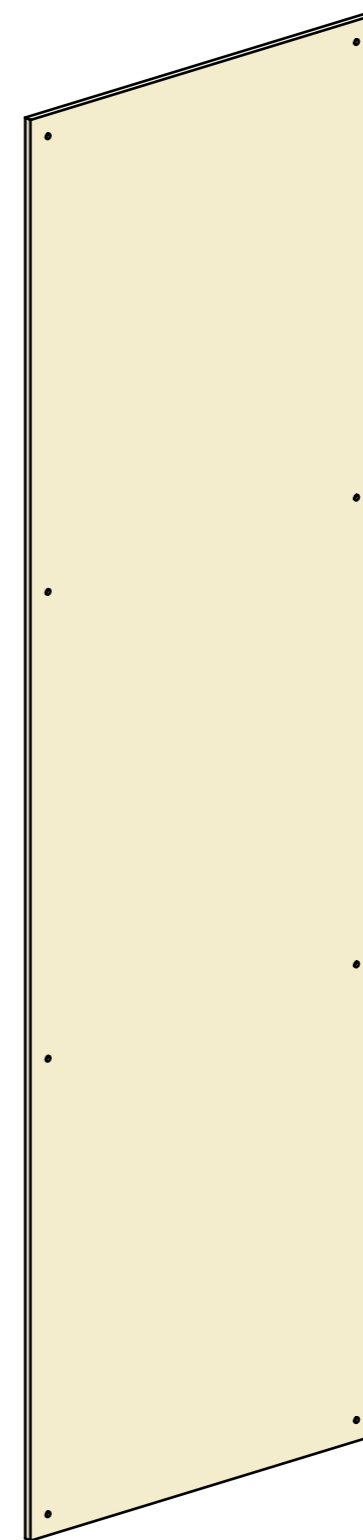
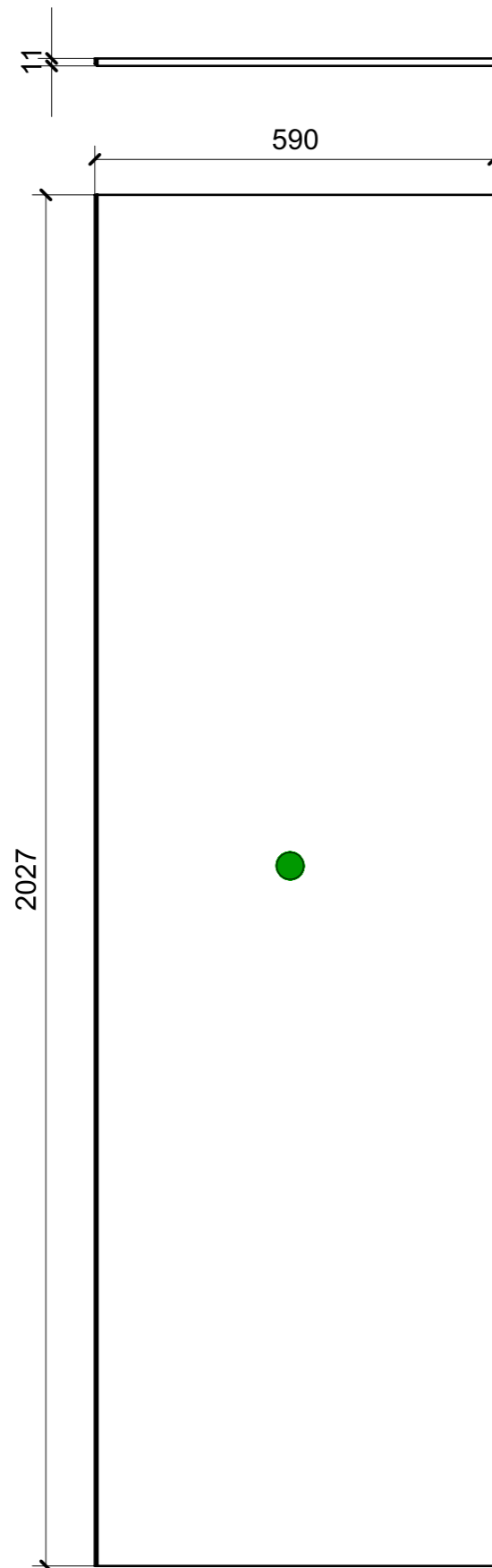

VERNICIATURA LASTRA/LACCATI:

● = FILI RASATI

● = VERNICIARE 1 LATO + FILI RASATI O BORDATI

NESSUN SIMBOLO = VERNICIARE 2 LATI + FILI RASATI O BORDATI

| LOCALE | CODICE | DESCRIZIONE COMPONENTE | FINITURA | GR. |
|--------|----------------|------------------------------|---------------|-----|
| CUCINA | MD320_R02_KU01 | RIV. PARATIA INGRESSO CUCINA | LASTRA CHIARA | 2 |

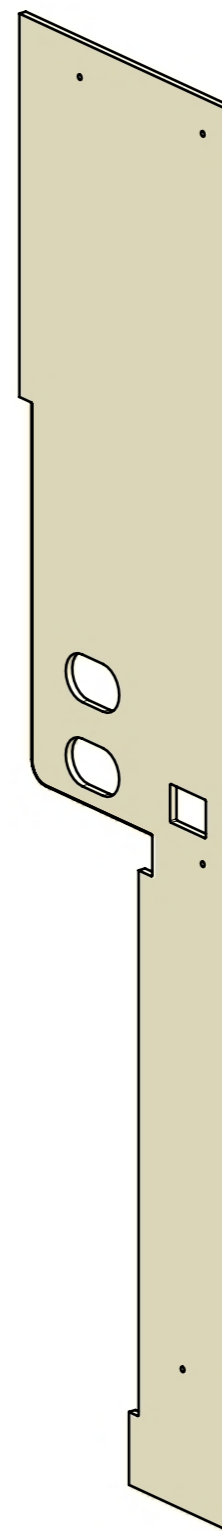
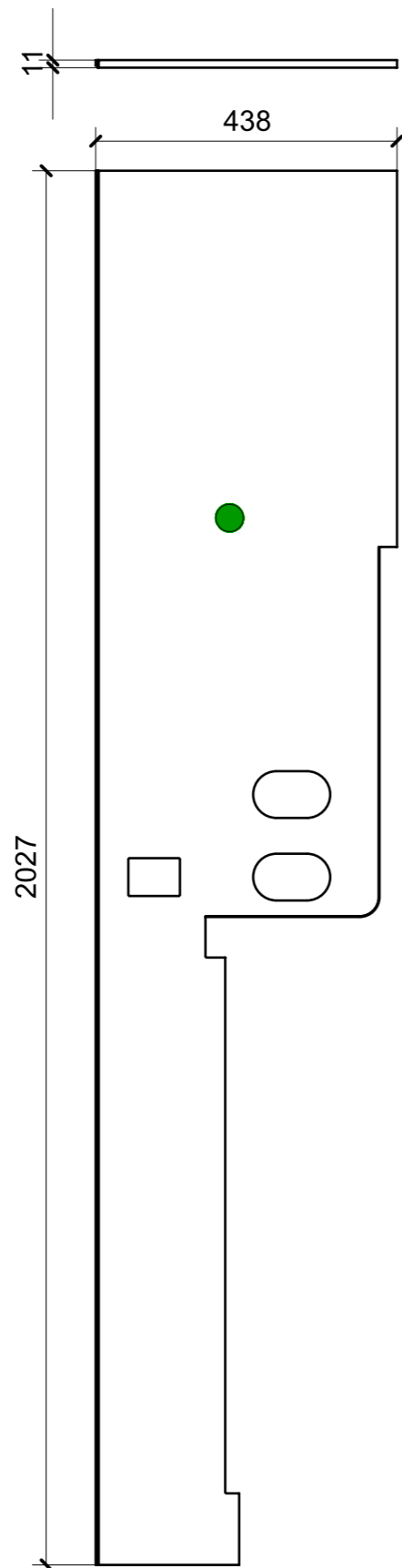

VERNICIATURA LASTRA/LACCATI:

● = VERNICIARE 1 LATO + FILI RASATI O BORDATI

NESSUN SIMBOLO = VERNICIARE 2 LATI + FILI RASATI O BORDATI

| LOCALE | CODICE | DESCRIZIONE COMPONENTE | FINITURA | GR. |
|--------|----------------|--|---------------|-----|
| CUCINA | MD320_R02_KV01 | RIV. INFERIORE PORTA SCORREVOLE CUCINA | LASTRA CHIARA | PTP |

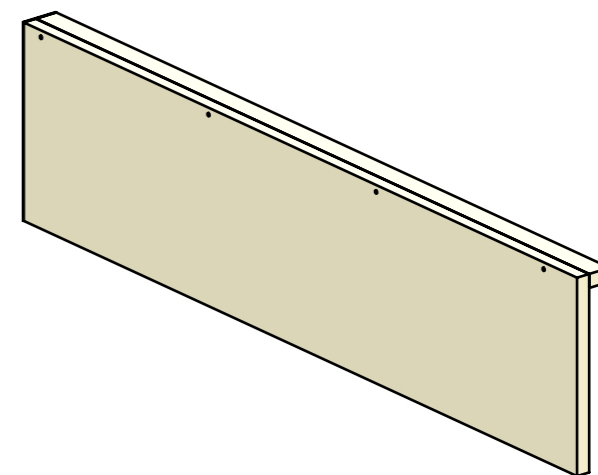
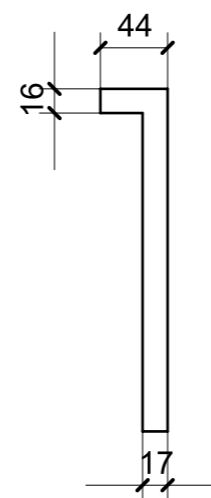
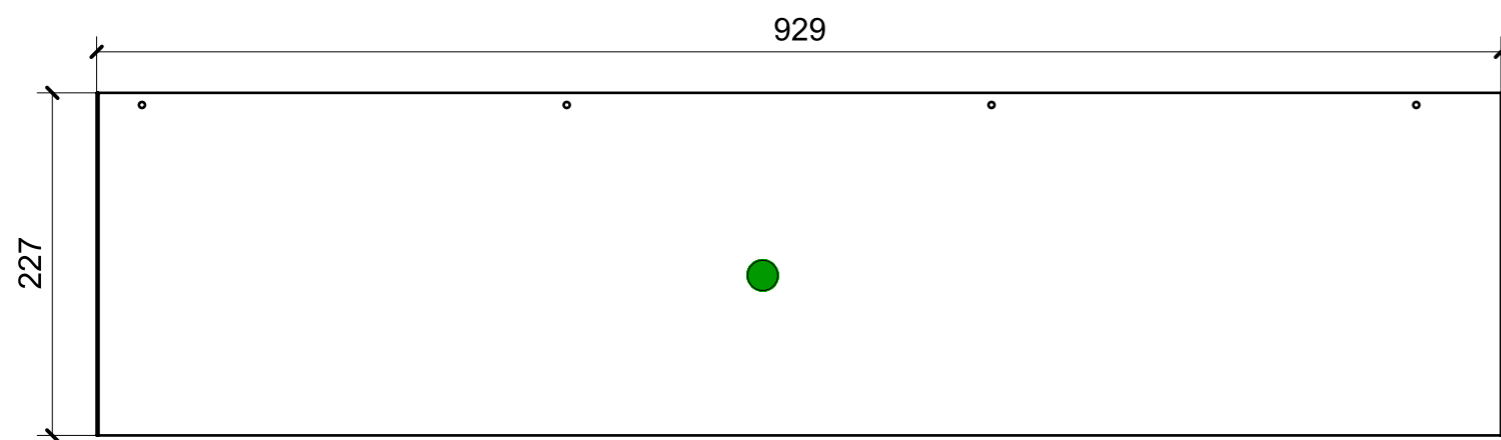

VERNICIATURA LASTRA/LACCATI:

● = FILI RASATI

● = VERNICIARE 1 LATO + FILI RASATI O BORDATI

NESSUN SIMBOLO = VERNICIARE 2 LATI + FILI RASATI O BORDATI