

LOCALE	CODICE	DESCRIZIONE COMPONENTE	FINITURA	GR.
SALONE	MD320_R01_SA01	STRUTTURA MURATA DX PRUA	LASTRA SCURA	2

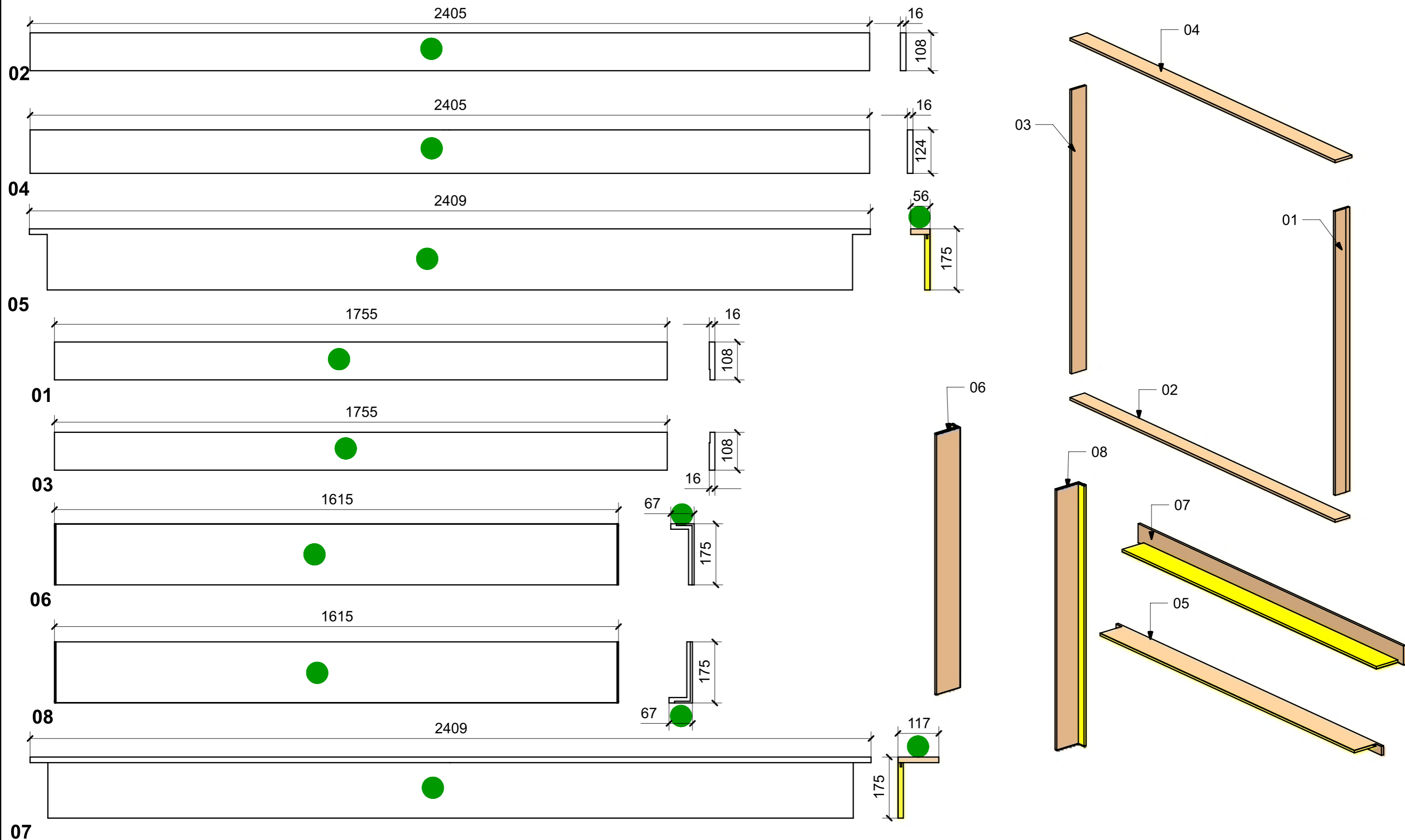

VERNICIATURA LASTRA/LACCATI:

● = VERNICIARE 1 LATO + FILI RASATI O BORDATI

NESSUN SIMBOLO = VERNICIARE 2 LATI + FILI RASATI O BORDATI

LOCALE	CODICE	DESCRIZIONE COMPONENTE	FINITURA	GR.
SALONE	MD320_R02_SA01	STRUTTURA MURATA DX PRUA	LASTRA CHIARA	2

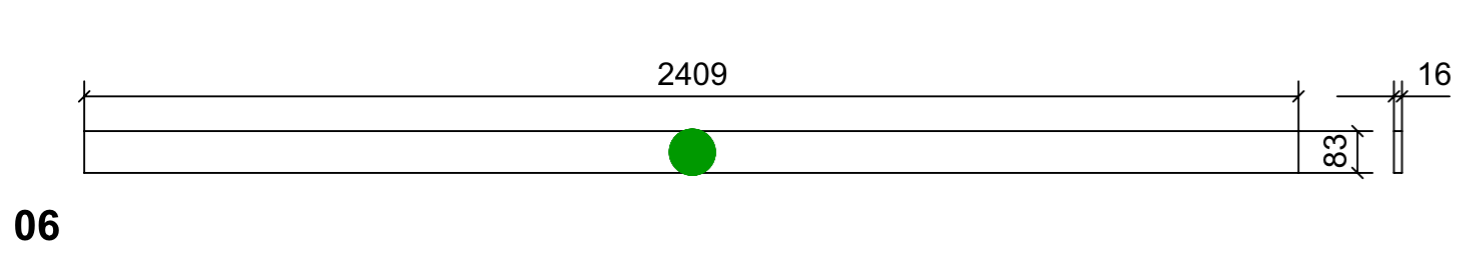
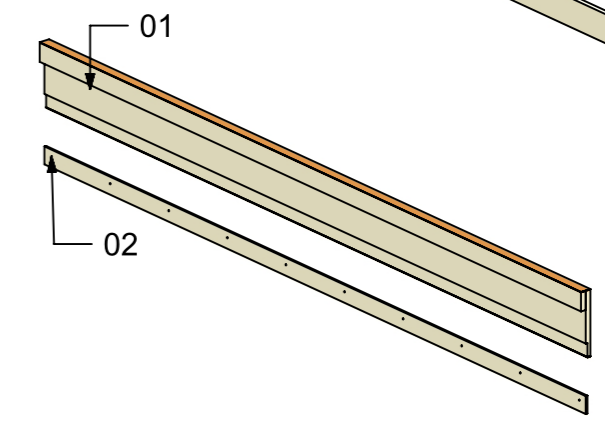
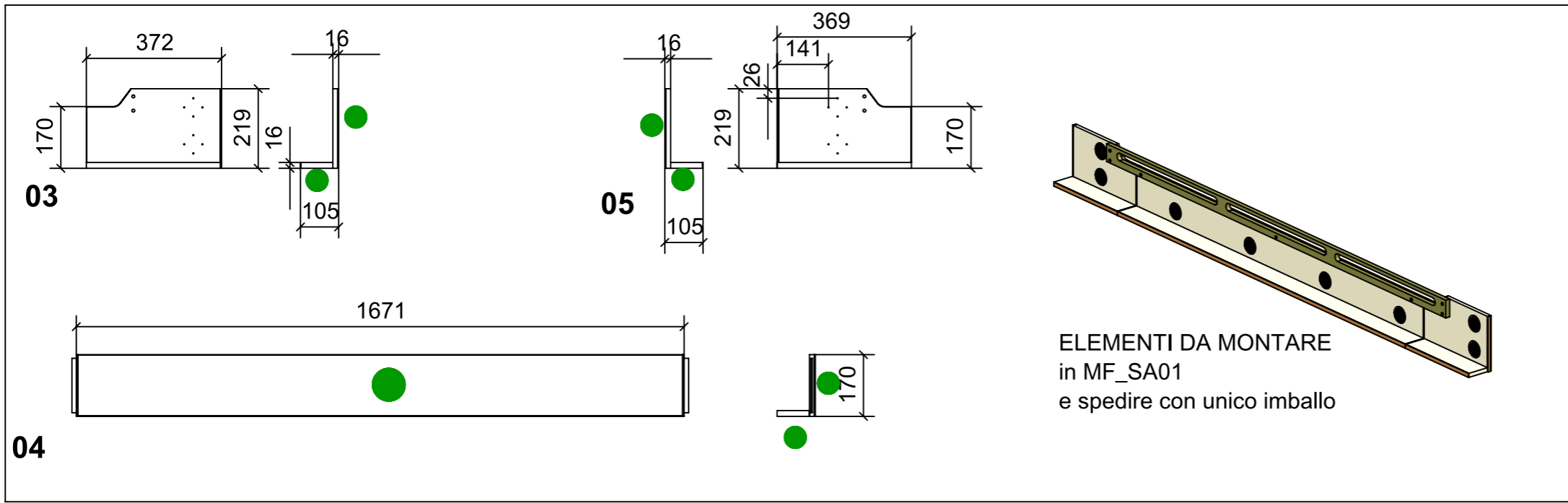
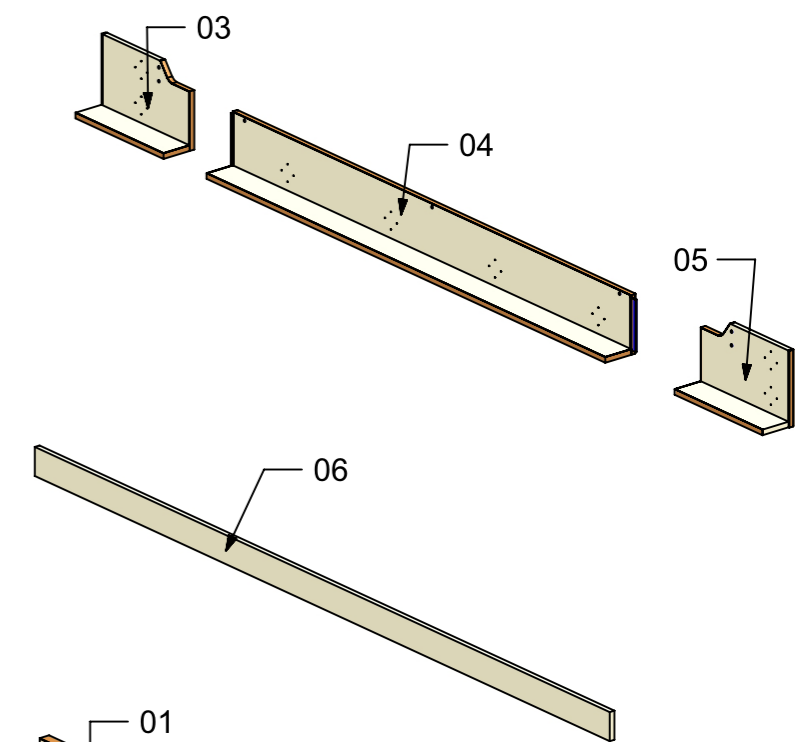
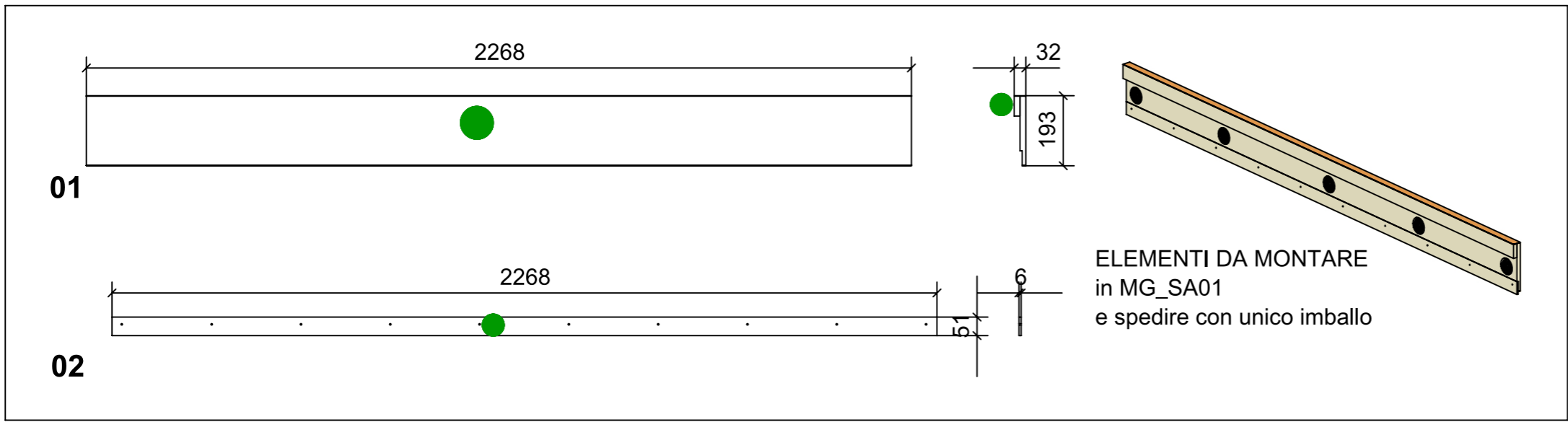

FERRAMENTA	QTY
FITLOCK F_MASCHERPA_6020101102	13
MD320_GR2_L01_SA01_01	1
BUSSOLA 6MA X 10 FORO DIAM.8	12
VITE 6MA X 25 TESTA SVASATA	7
FITLOCK M_MASCHERPA_3MM_6020202101	13

**VERNICIATURA LASTRA/LACCATI:**  
 ● = VERNICIARE 1 LATO + FILI RASATI O BORDATI      NESSUN SIMBOLO = VERNICIARE 2 LATI + FILI RASATI O BORDATI

LOCALE	CODICE	DESCRIZIONE COMPONENTE	FINITURA	GR.
SALONE	MD320_R02_SC01	STRUTTURA MONTANTE DX	LASTRA CHIARA	PTP

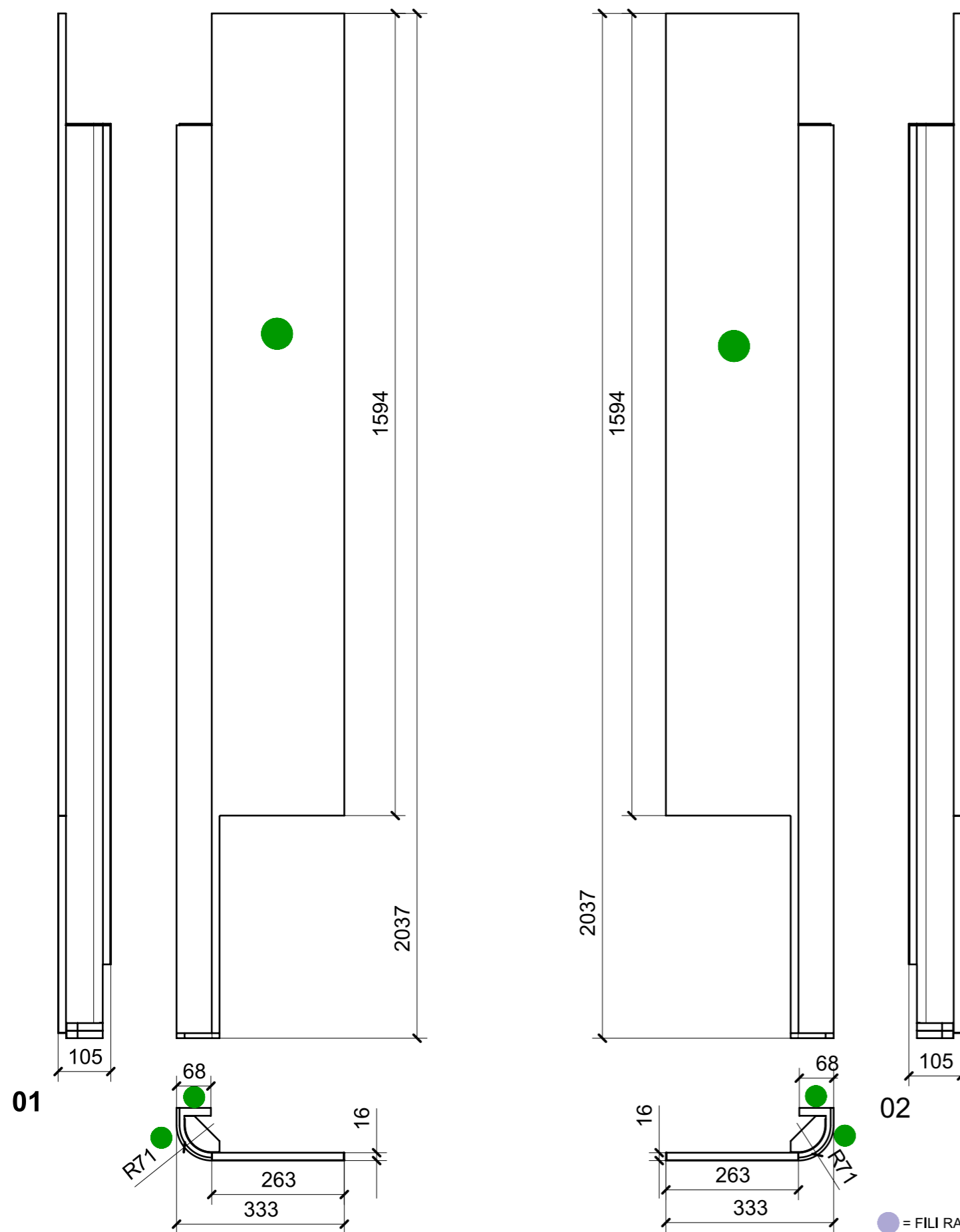

ELEMENTI DA MONTARE  
in MF\_SC01\ MF\_SC02  
e spedire con unico imballo

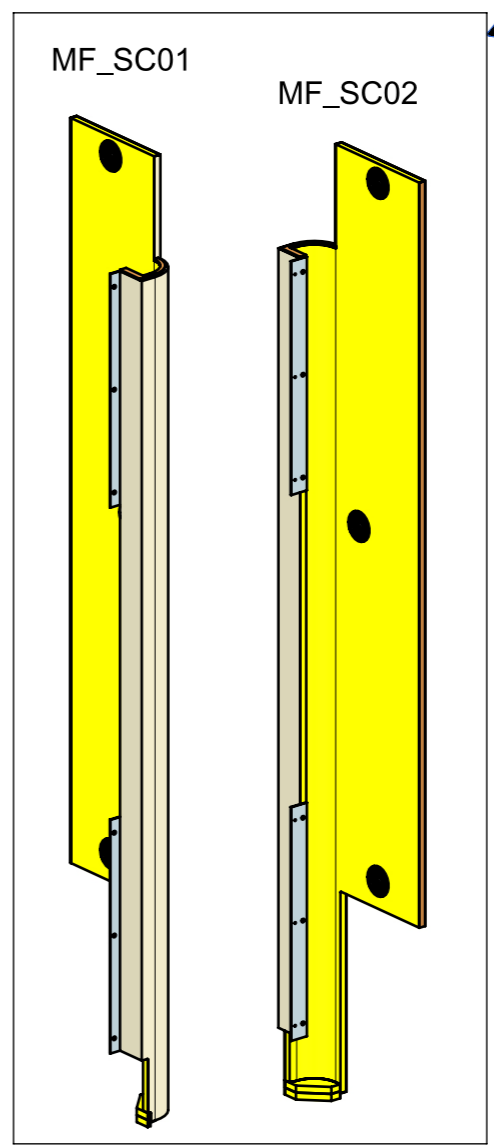

FERRAMENTA	QTY
FITLOCK M_MASCHERPA_3MM_6020202101	6

VERNICIATURA LASTRA/LACCATI:  
NESSUN SIMBOLO = VERNICIARE 2 LATI + FILI RASATI O BORDATI

LOCALE	CODICE	DESCRIZIONE COMPONENTE	FINITURA	GR.
SALONE	MD320_R01_SD01	STRUTTURA MURATA DX POPPA	LASTRA SCURA	3

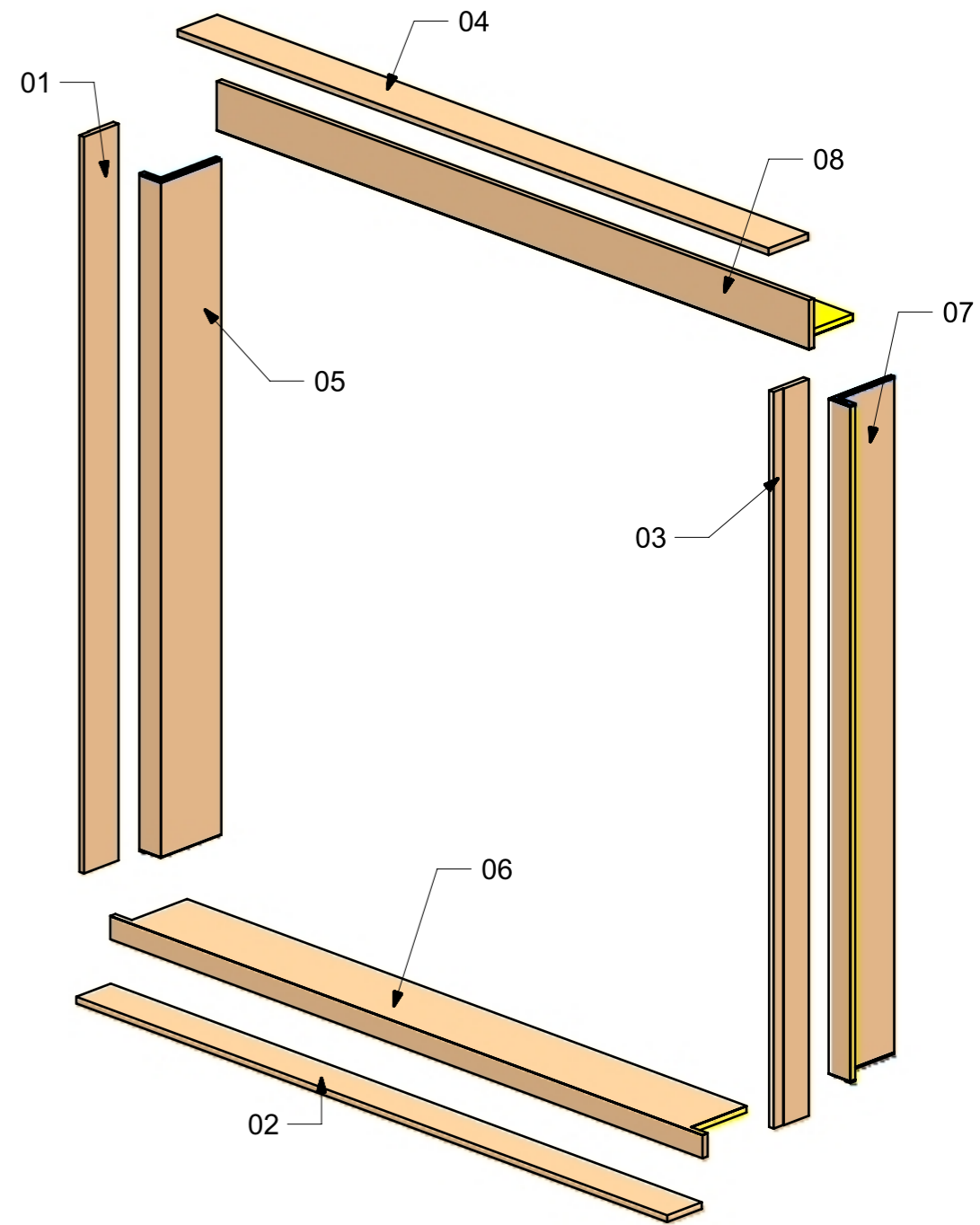
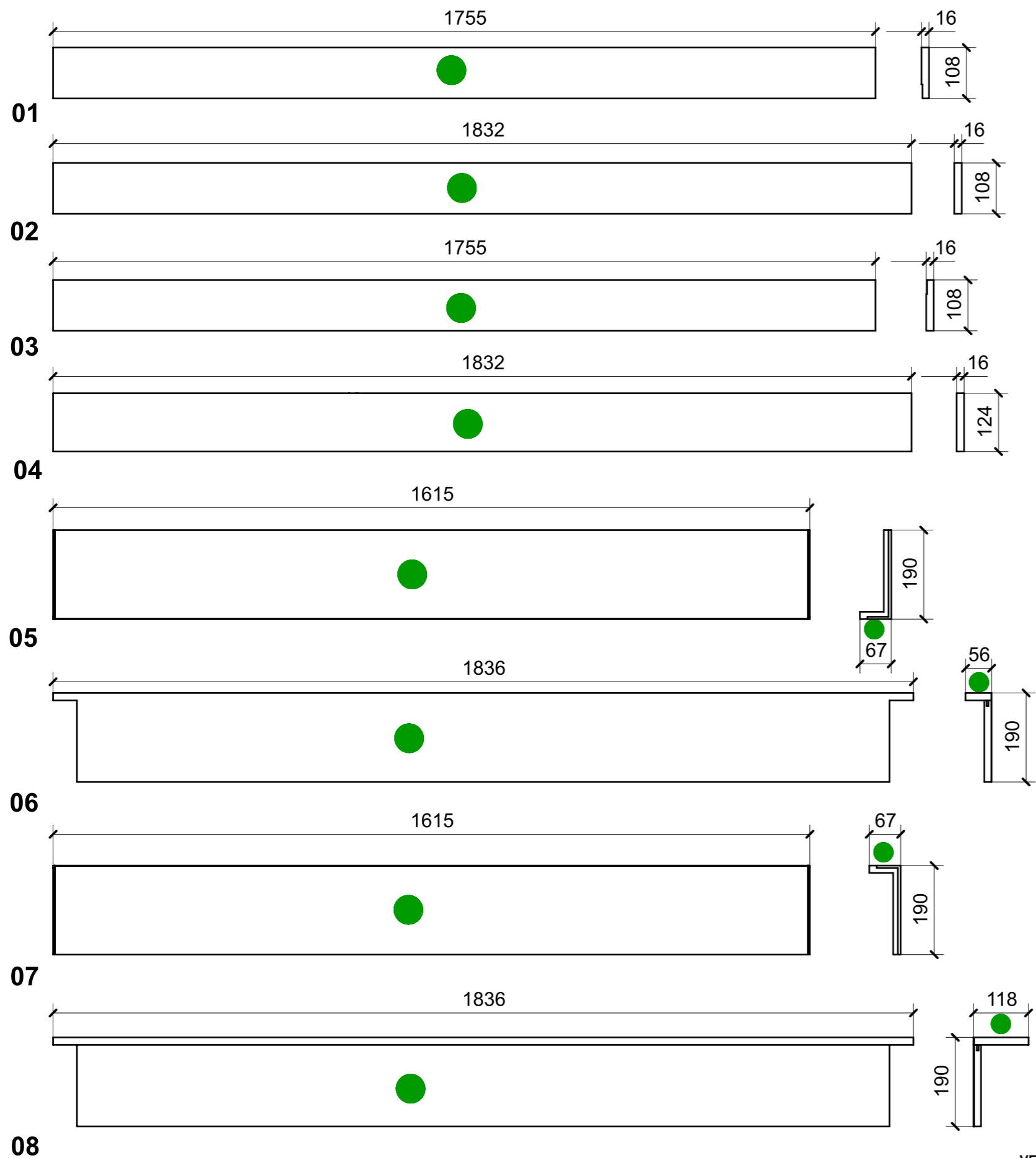

VERNICIATURA LASTRA/LACCATI:

● = VERNICIARE 1 LATO + FILI RASATI O BORDATI

NESSUN SIMBOLO = VERNICIARE 2 LATI + FILI RASATI O BORDATI

<b>LOCALE</b>	<b>CODICE</b>	<b>DESCRIZIONE COMPONENTE</b>	<b>FINITURA</b>	<b>GR.</b>
SALONE	MD320_R02_SD01	STRUTTURA MURATA DX POPPA	LASTRA CHIARA	3

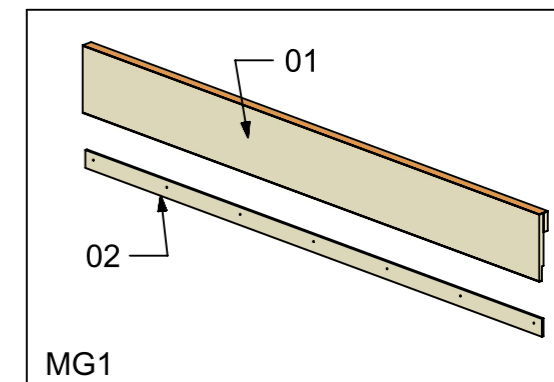
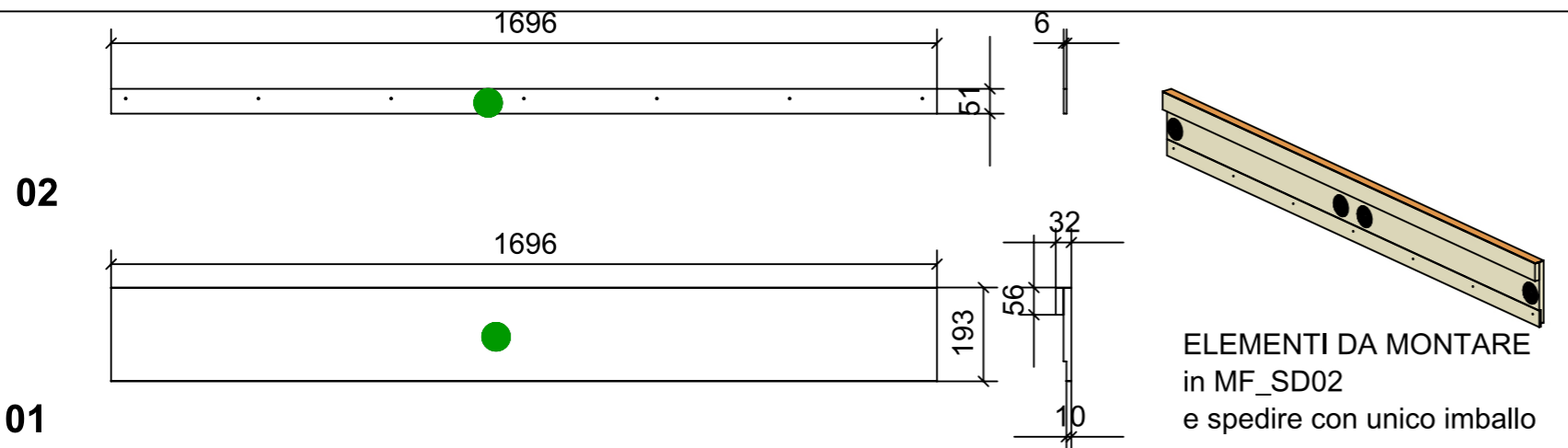
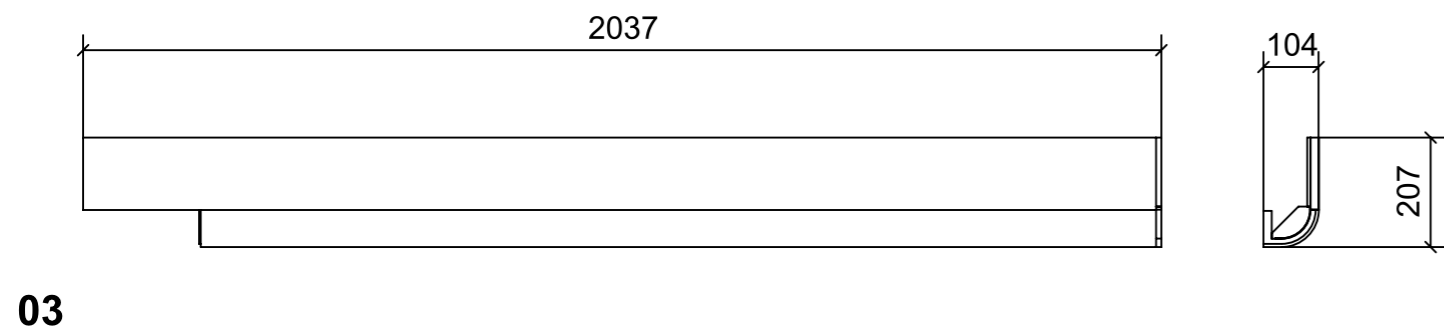
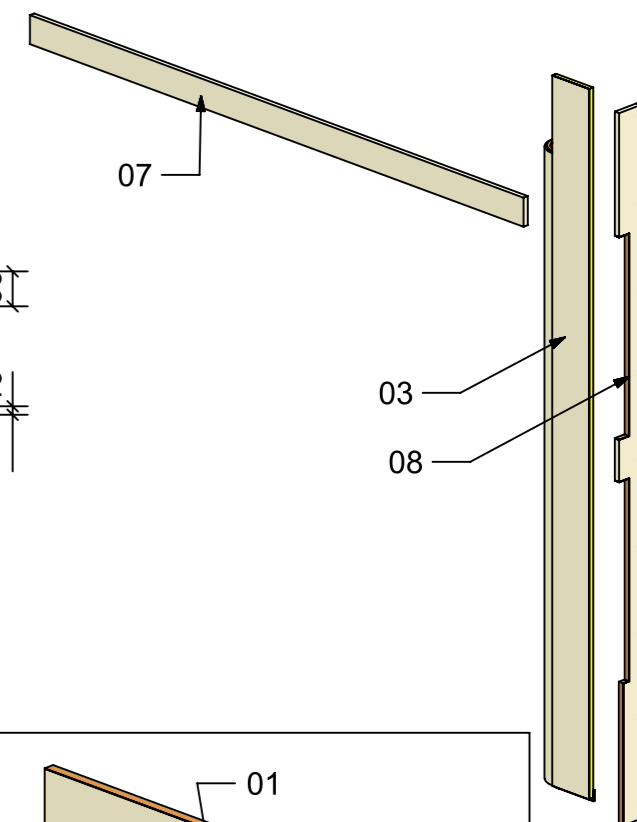
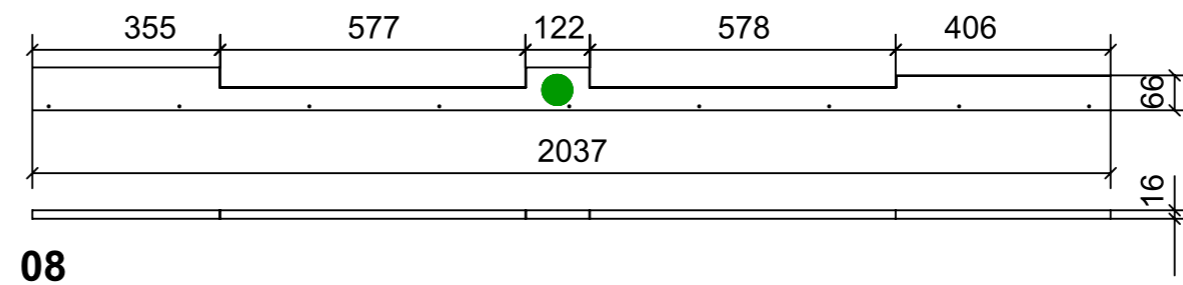
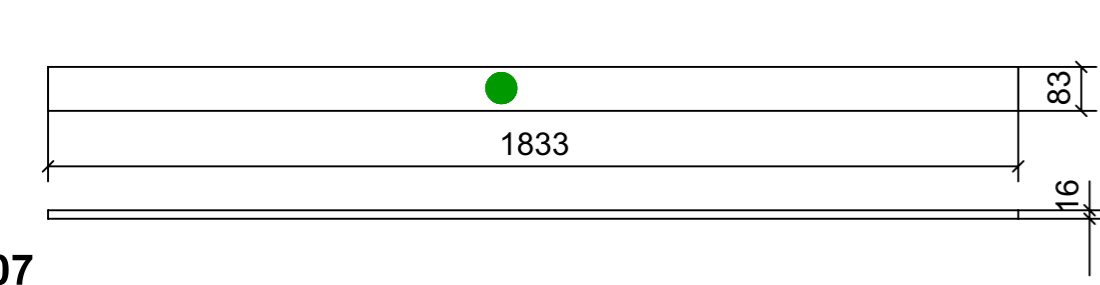
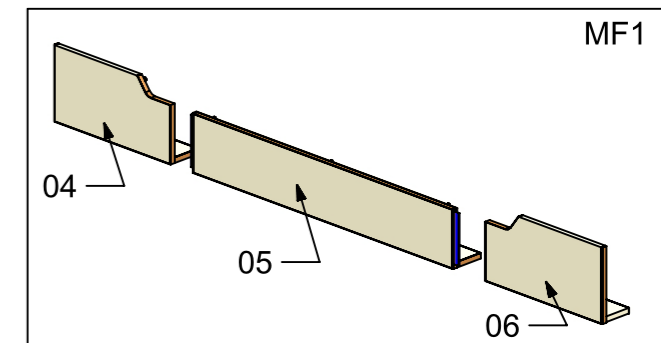
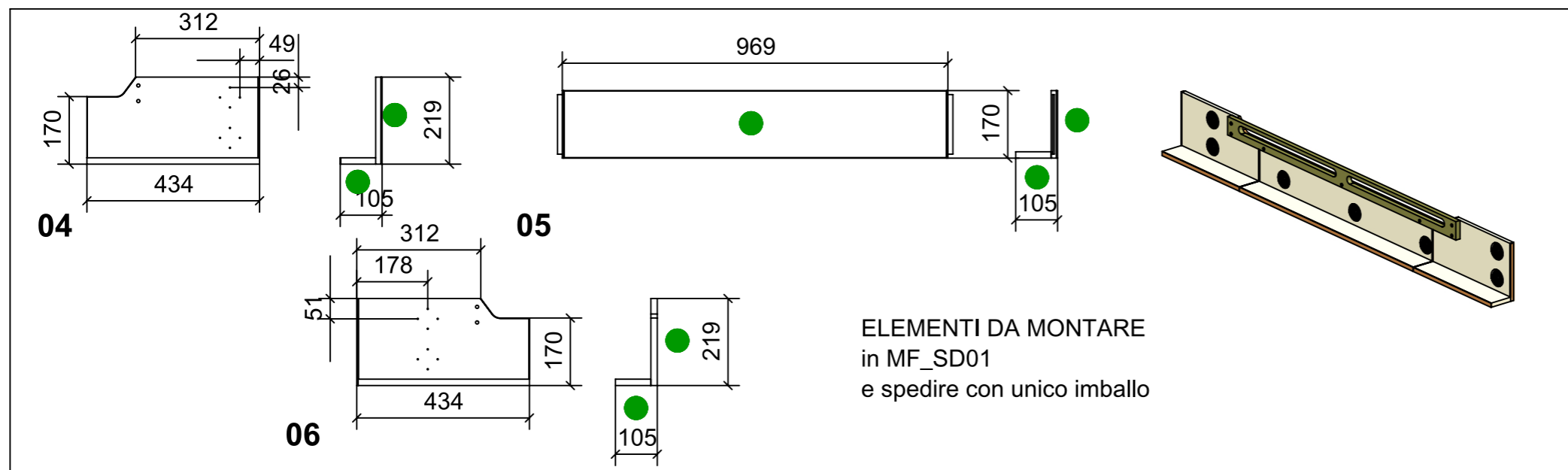

FERRAMENTA	QTY
BUSSOLA 6MA X 10 FORO DIAM.8	7
VITE 6MA X 25 TESTA SVASATA	7
FITLOCK M_MASCHERPA_3MM_6020202101	14

VERNICIATURA LASTRA/LACCATI:

● = VERNICIARE 1 LATO + FILI RASATI O BORDATI

NESSUN SIMBOLO = VERNICIARE 2 LATI + FILI RASATI O BORDATI

LOCALE	CODICE	DESCRIZIONE COMPONENTE	FINITURA	GR.
SALONE	MD320_R01_SF01	STRUTTURA MURATA SX PRUA	LASTRA SCURA	3

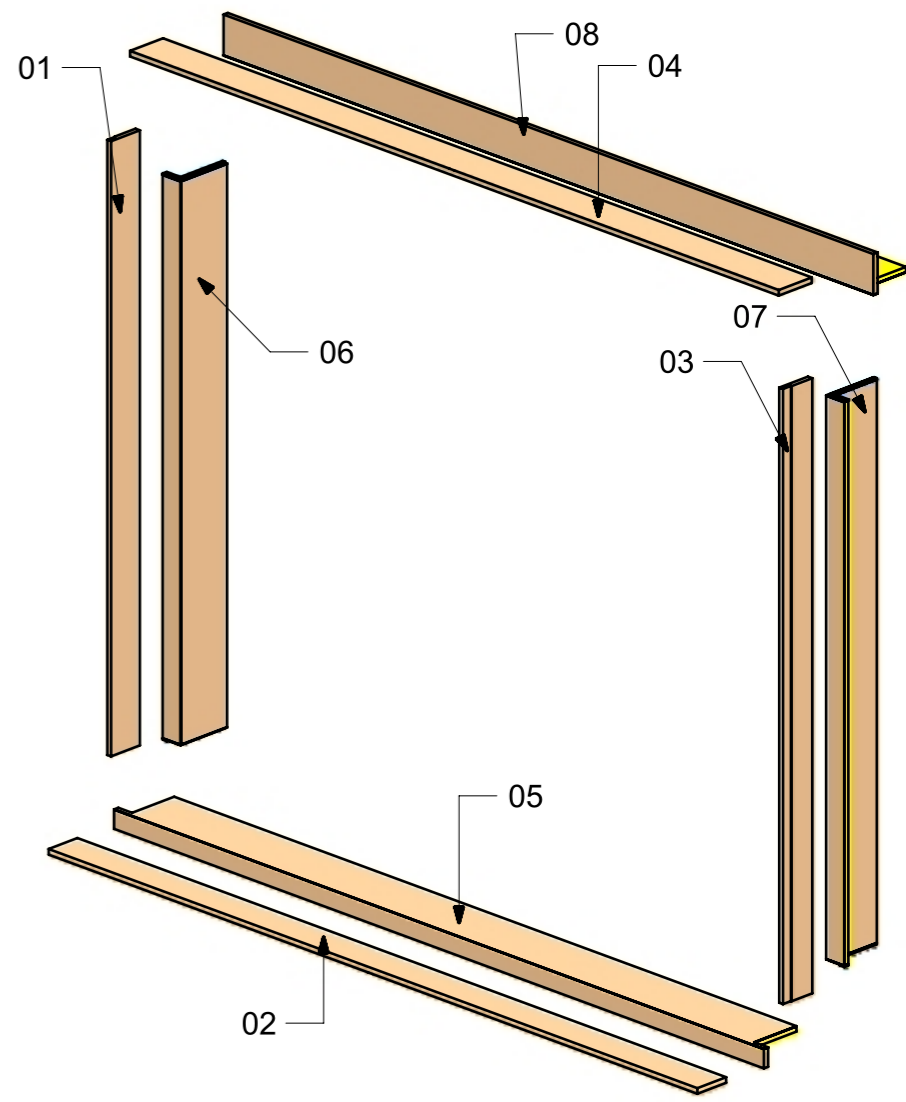
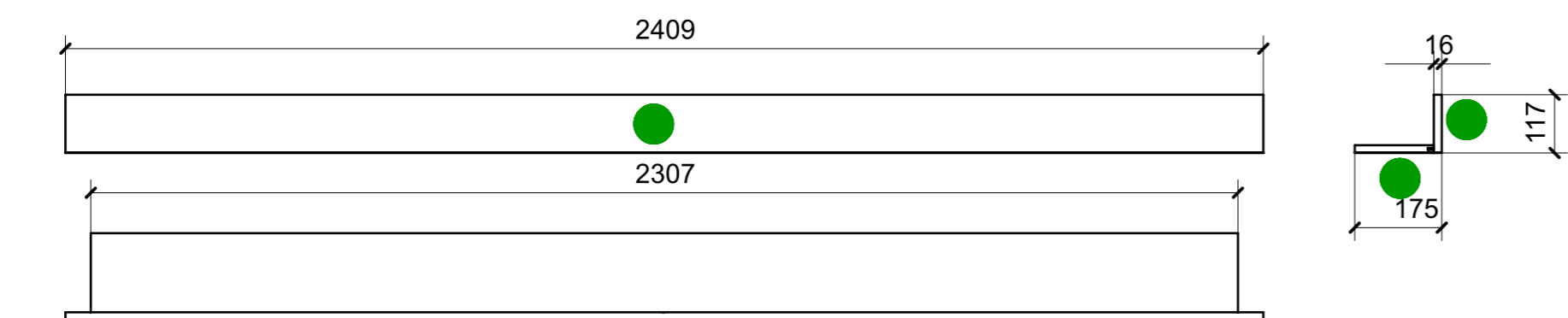
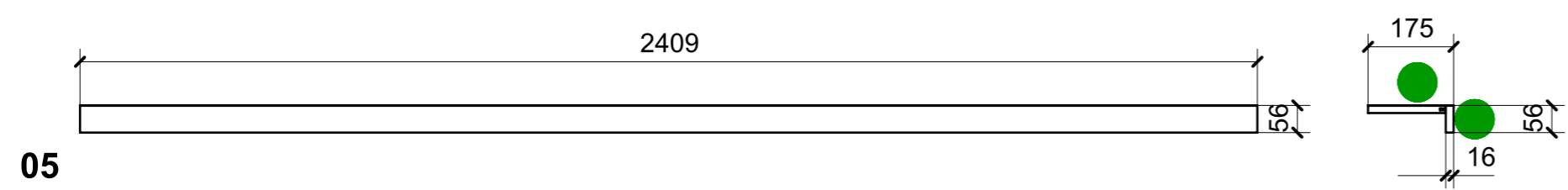
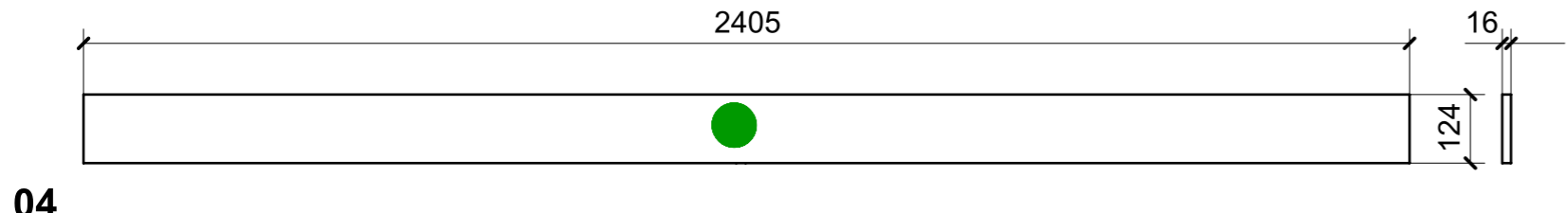
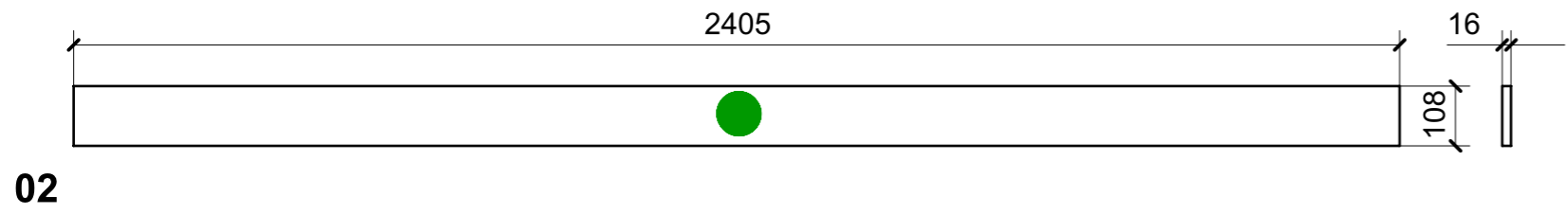
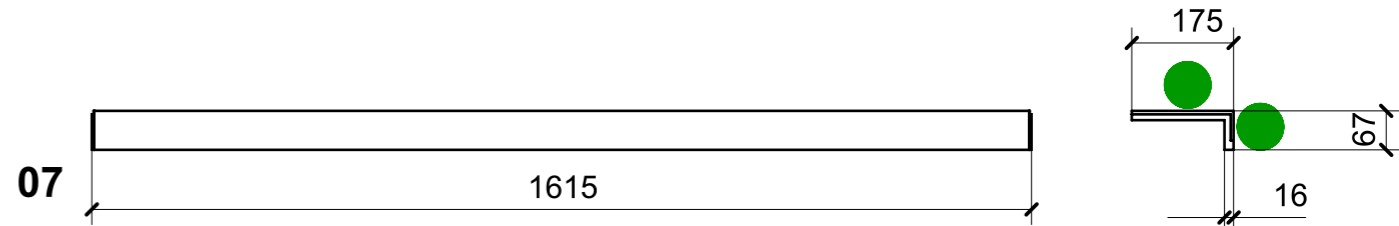
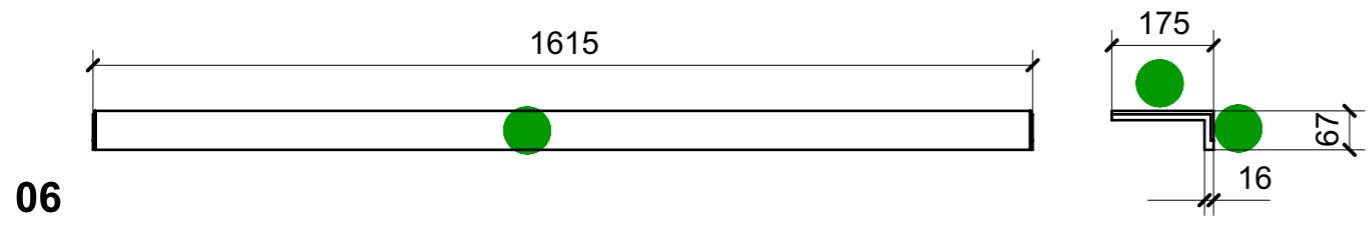
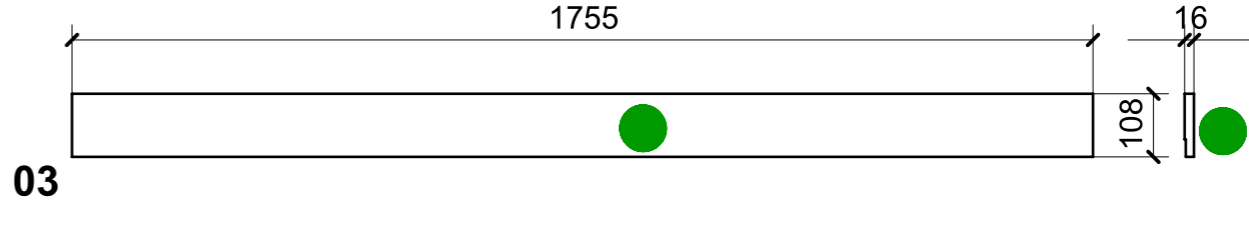
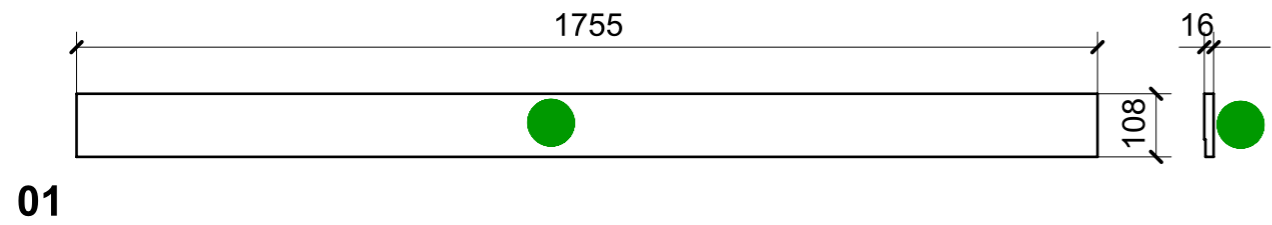

VERNICIATURA LASTRA/LACCATI:

● = VERNICIARE 1 LATO + FILI RASATI O BORDATI

NESSUN SIMBOLO = VERNICIARE 2 LATI + FILI RASATI O BORDATI

LOCALE	CODICE	DESCRIZIONE COMPONENTE	FINITURA	GR.
SALONE	MD320_R02_SF01	STRUTTURA MURATA SX PRUA	LASTRA CHIARA	3

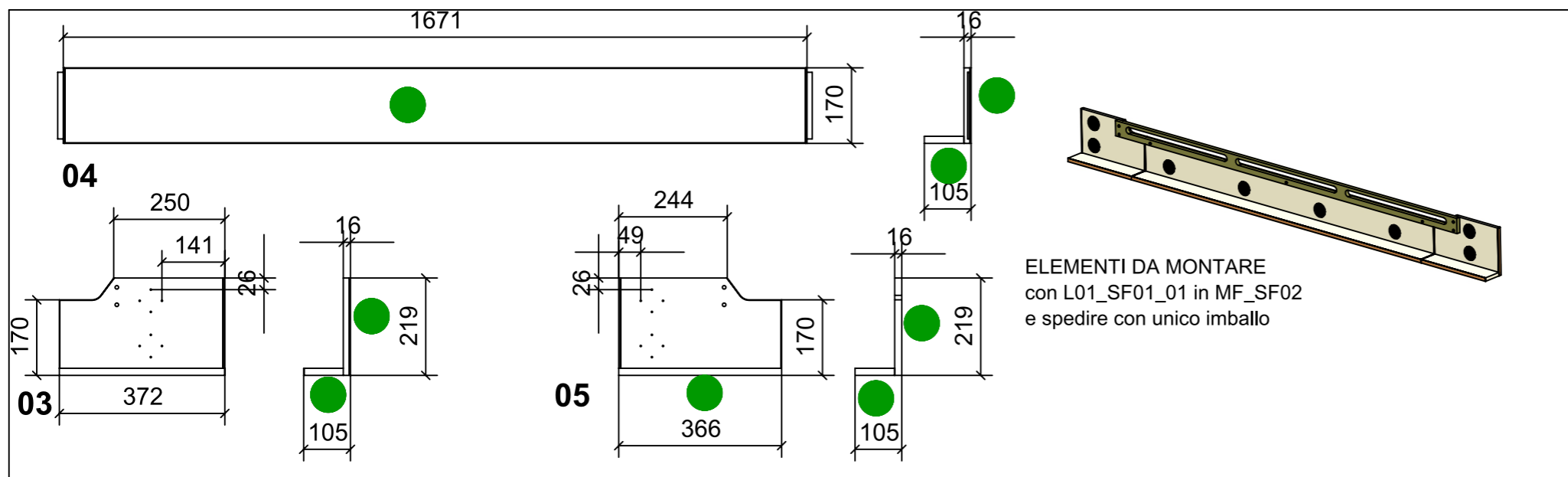

ELEMENTI DA MONTARE  
con L01\_SF01\_01 in MF\_SF02  
e spedire con unico imballo

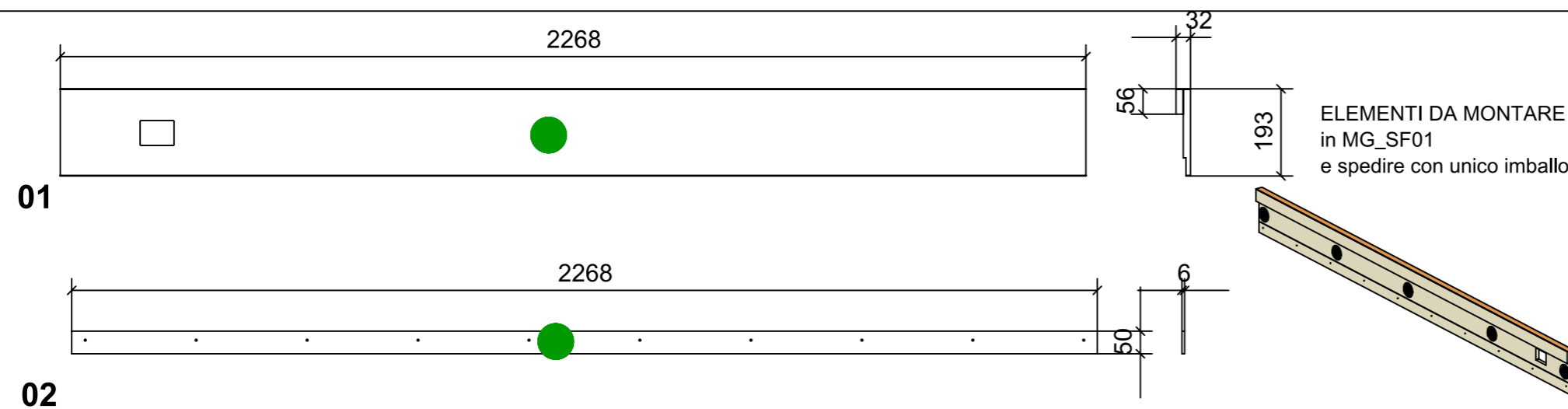
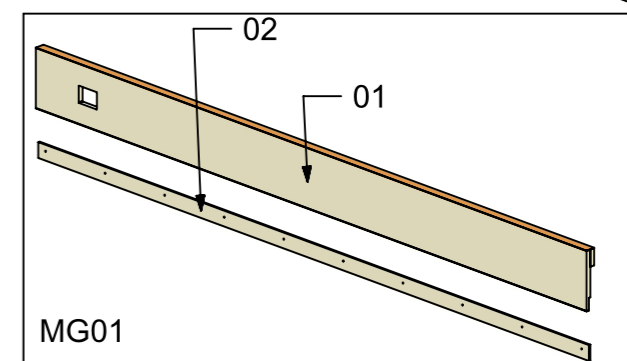
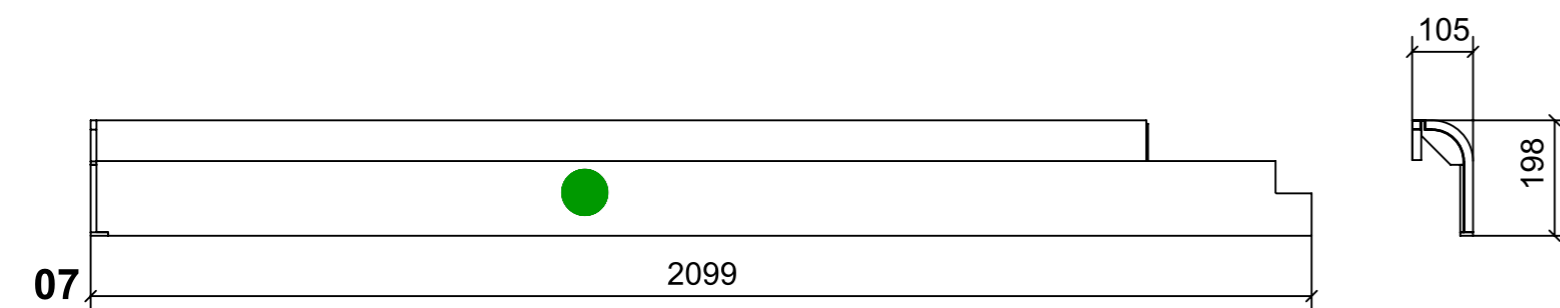
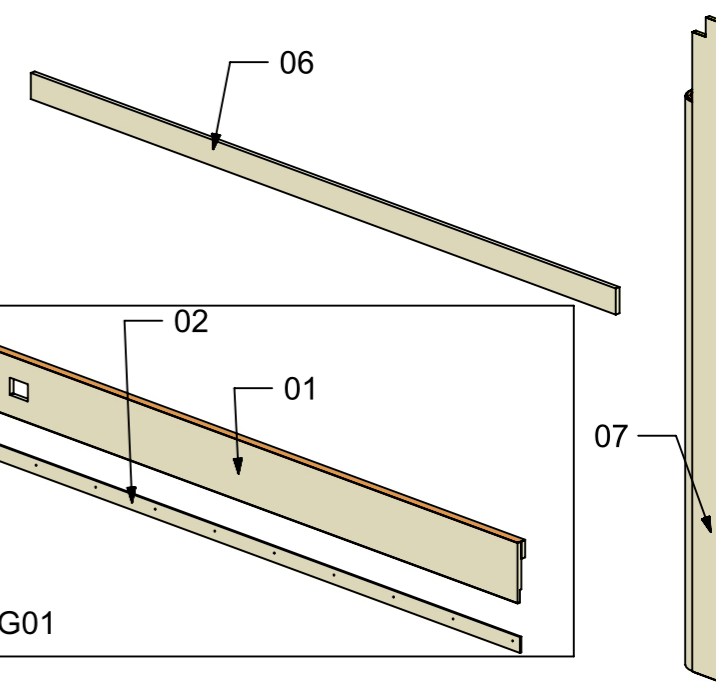
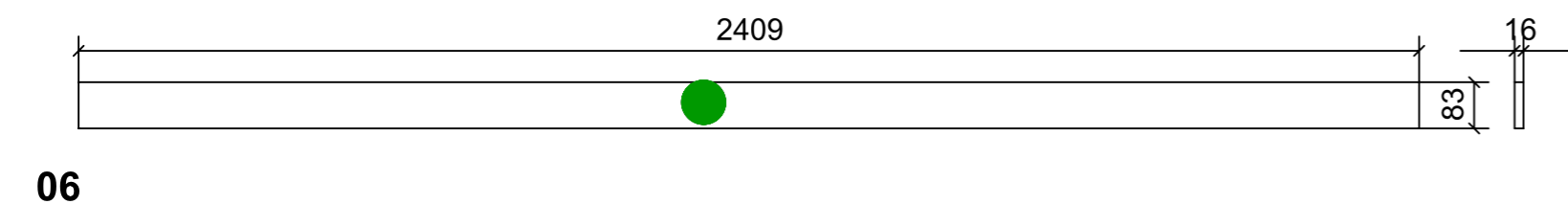
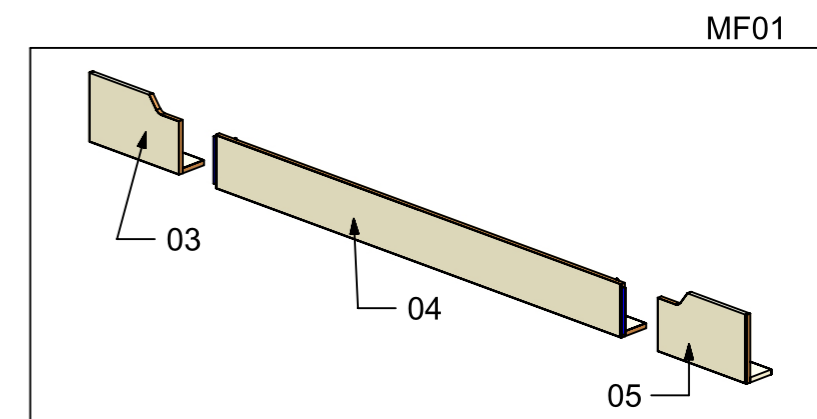

ELEMENTI DA MONTARE  
in MG\_SF01  
e spedire con unico imballo

FERRAMENTA	QTY
FITLOCK M_MASCHERPA_3MM_6020202101	3

VERNICIATURA LASTRA/LACCATI:

● = VERNICIARE 1 LATO + FILI RASATI O BORDATI

NESSUN SIMBOLO = VERNICIARE 2 LATI + FILI RASATI O BORDATI

LOCALE	CODICE	DESCRIZIONE COMPONENTE	FINITURA	GR.
SALONE	MD320_R02_SH01	STRUTTURA MONTANTE SX	LAISTRA CHIARA	PTP

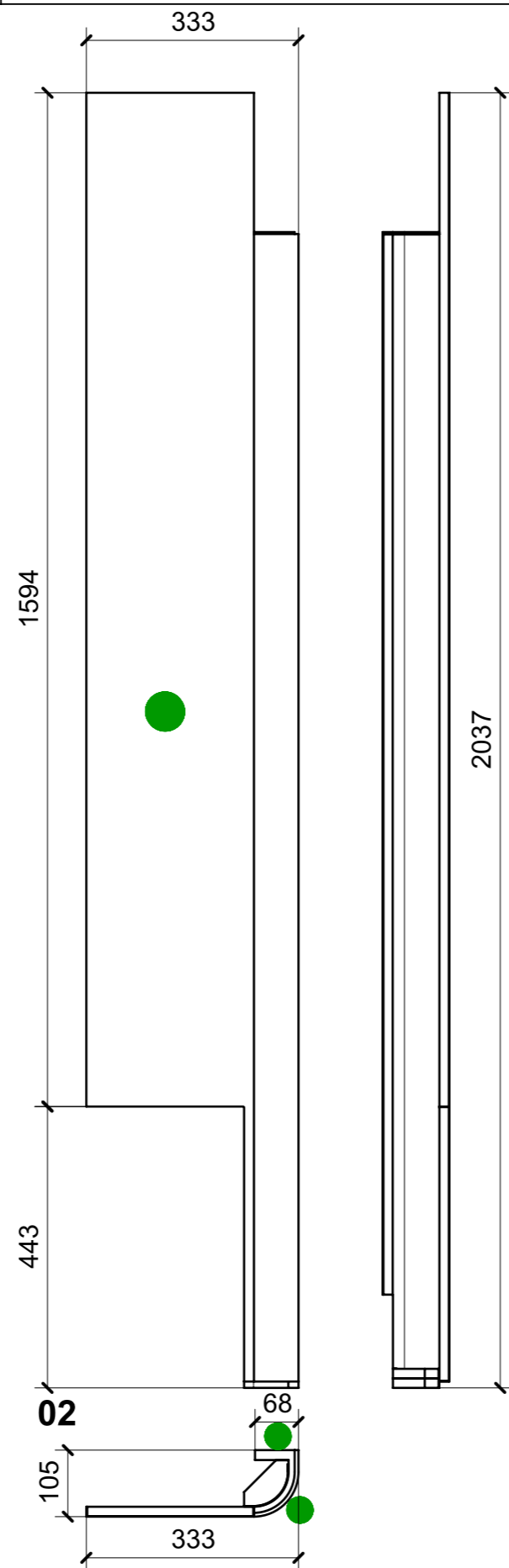
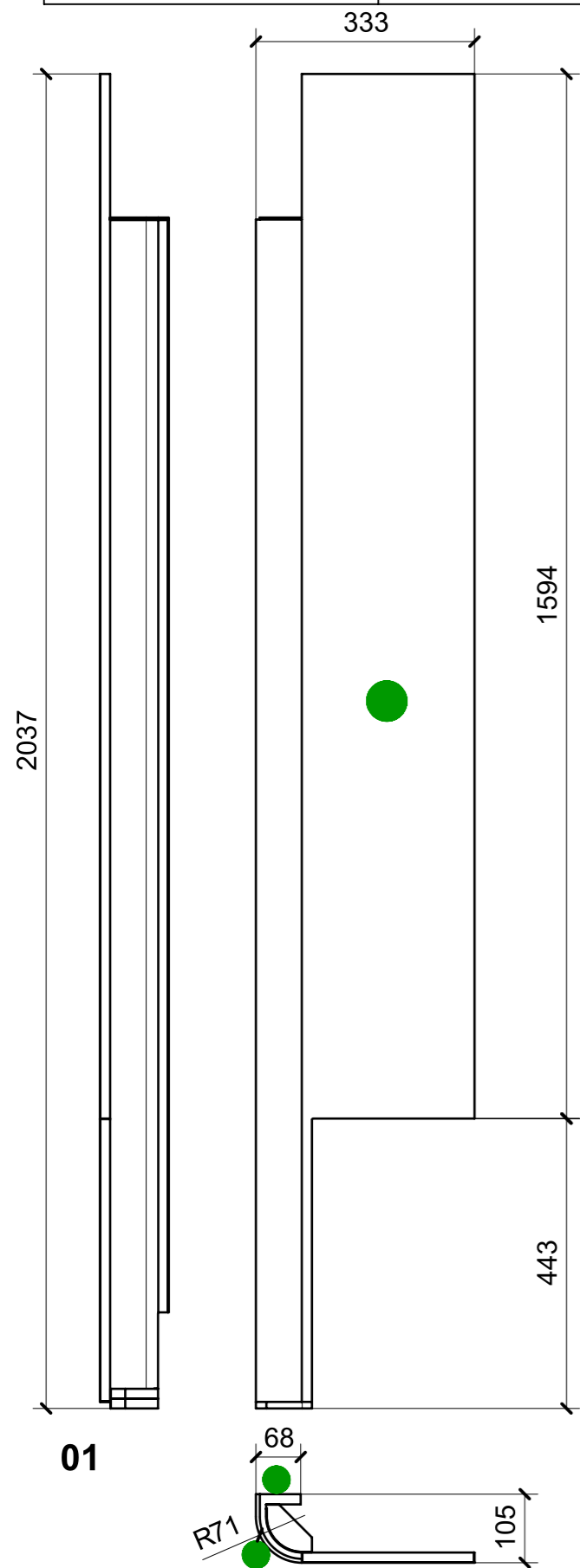

MF\_SH01

MF\_SH02

ELEMENTI DA MONTARE  
in MF\_SH01\SH02  
e spedire con unico imballo

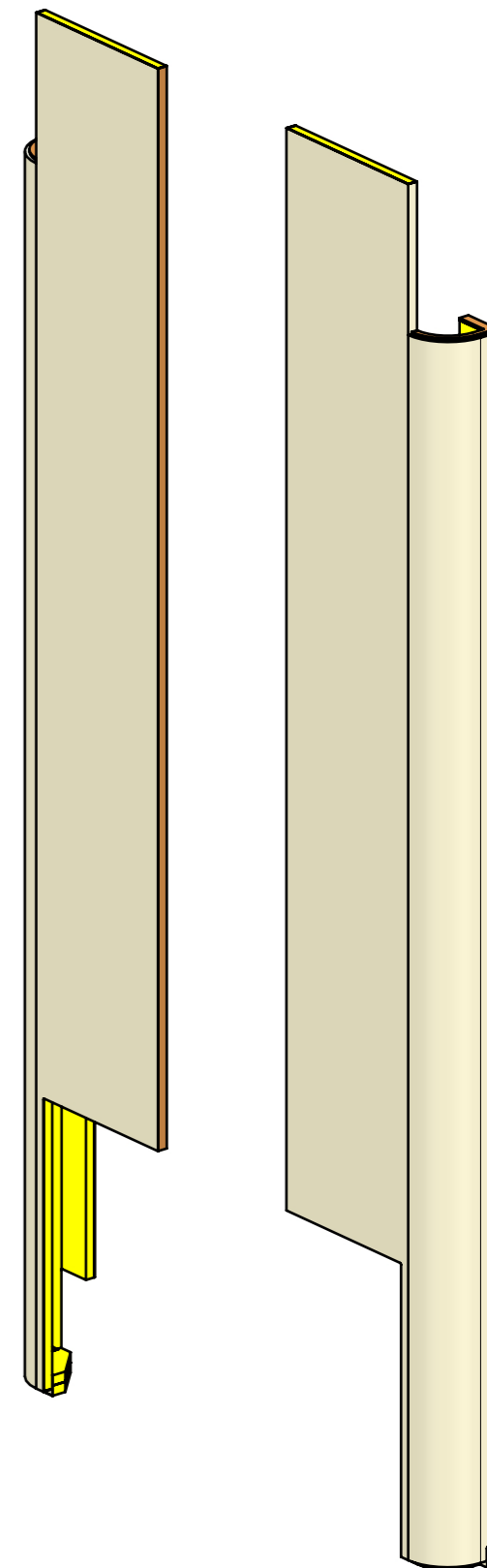

FERRAMENTA	QTY
FITLOCK M_MASCHERPA_3MM_6020202101	6

● = FILI RASATI

VERNICIATURA LAISTRA/LACCATI:

● = VERNICIARE 1 LATO + FILI RASATI O BORDATI

NESSUN SIMBOLO = VERNICIARE 2 LATI + FILI RASATI O BORDATI

LOCALE	CODICE	DESCRIZIONE COMPONENTE	FINITURA	GR.
SALONE	MD320_R01_SI01	STRUTTURA MURATA SX POPPA	LASTRA SCURA	3

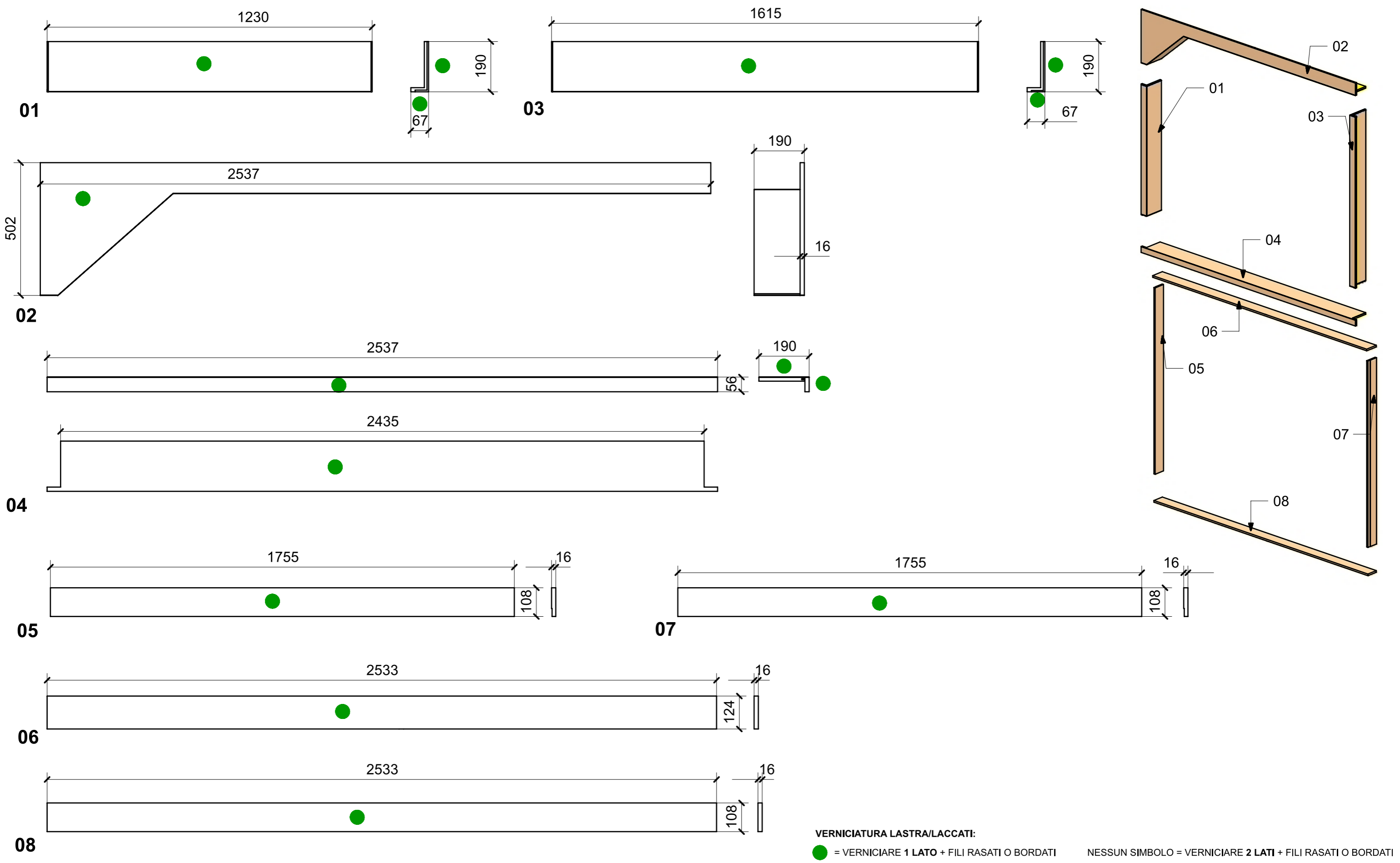

VERNICIATURA LASTRA/LACCATI:

● = VERNICIARE 1 LATO + FILI RASATI O BORDATI

NESSUN SIMBOLO = VERNICIARE 2 LATI + FILI RASATI O BORDATI

LOCALE	CODICE	DESCRIZIONE COMPONENTE	FINITURA	GR.
SALONE	MD320_R02_SI01	STRUTTURA MURATA SX POPPA	LASTRA CHIARA	3

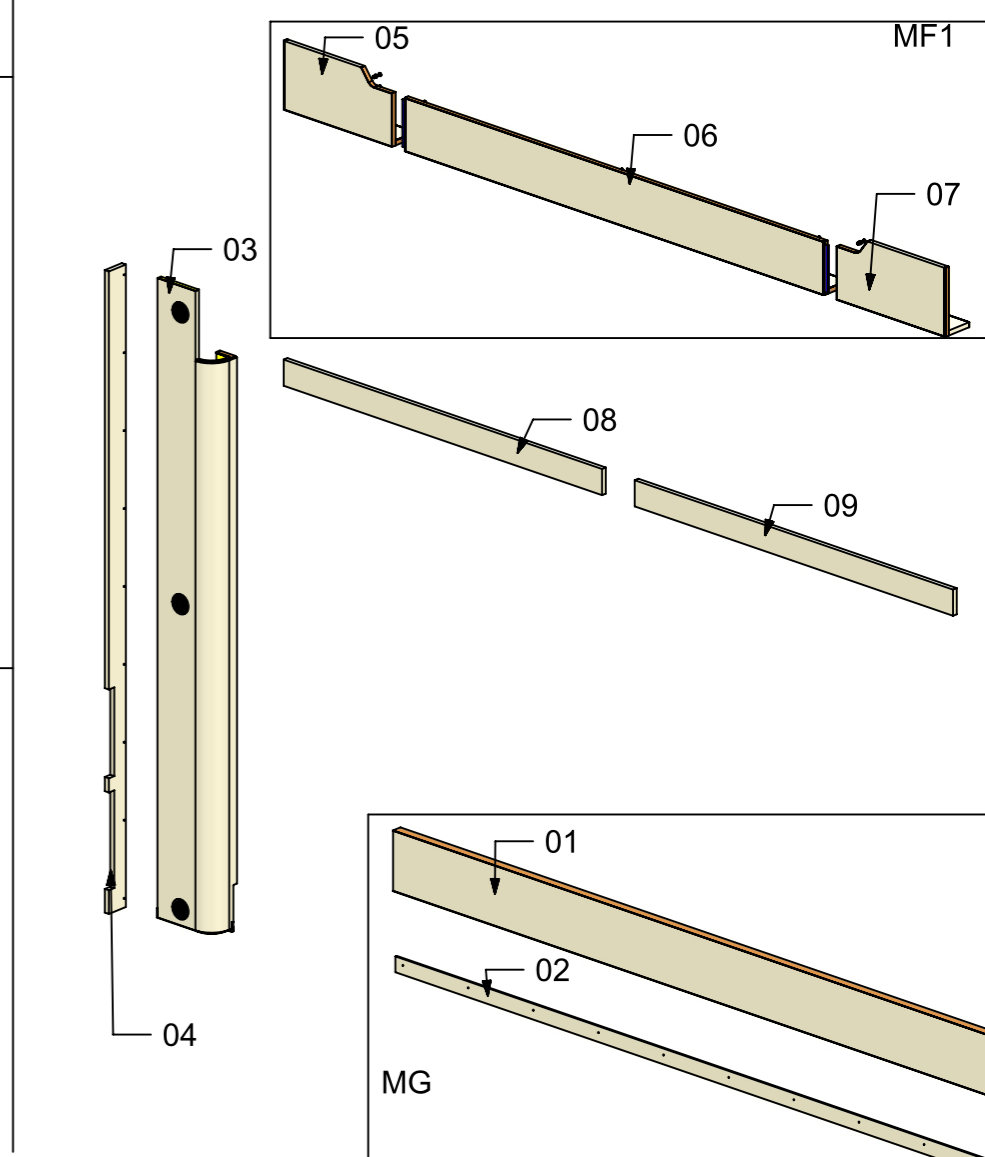
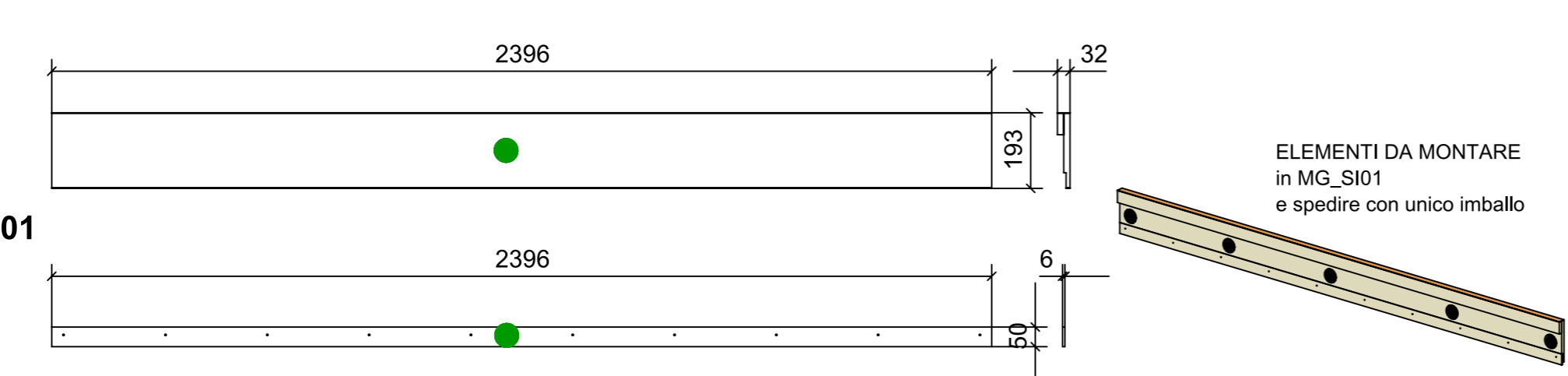
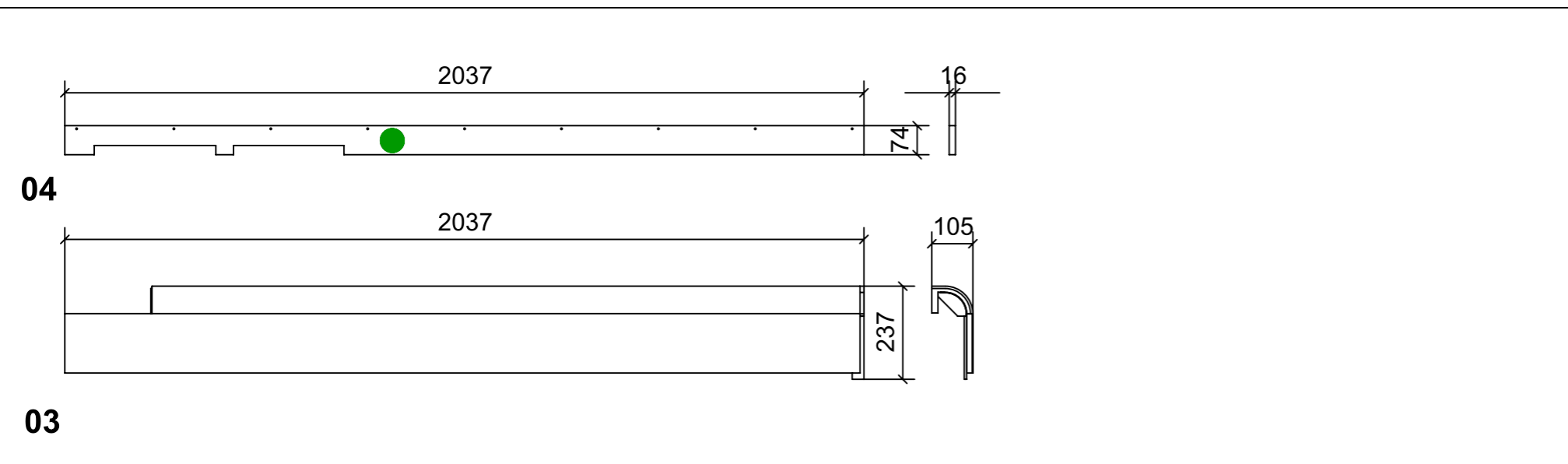
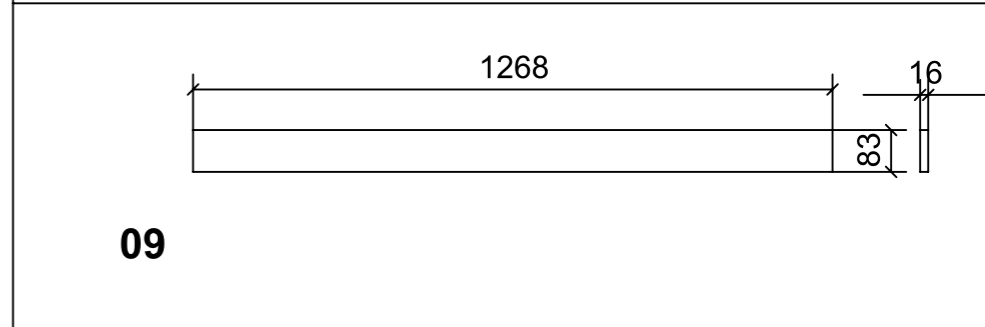
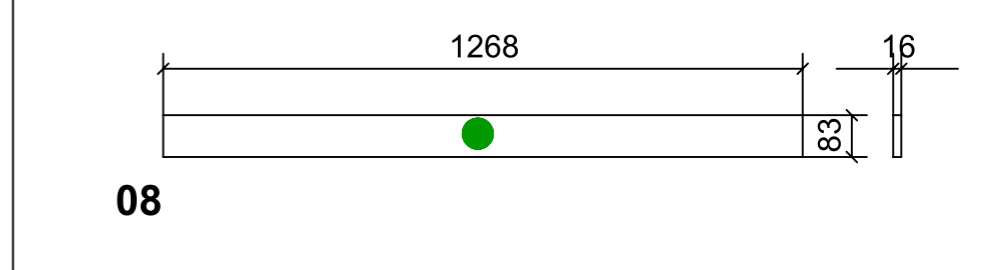
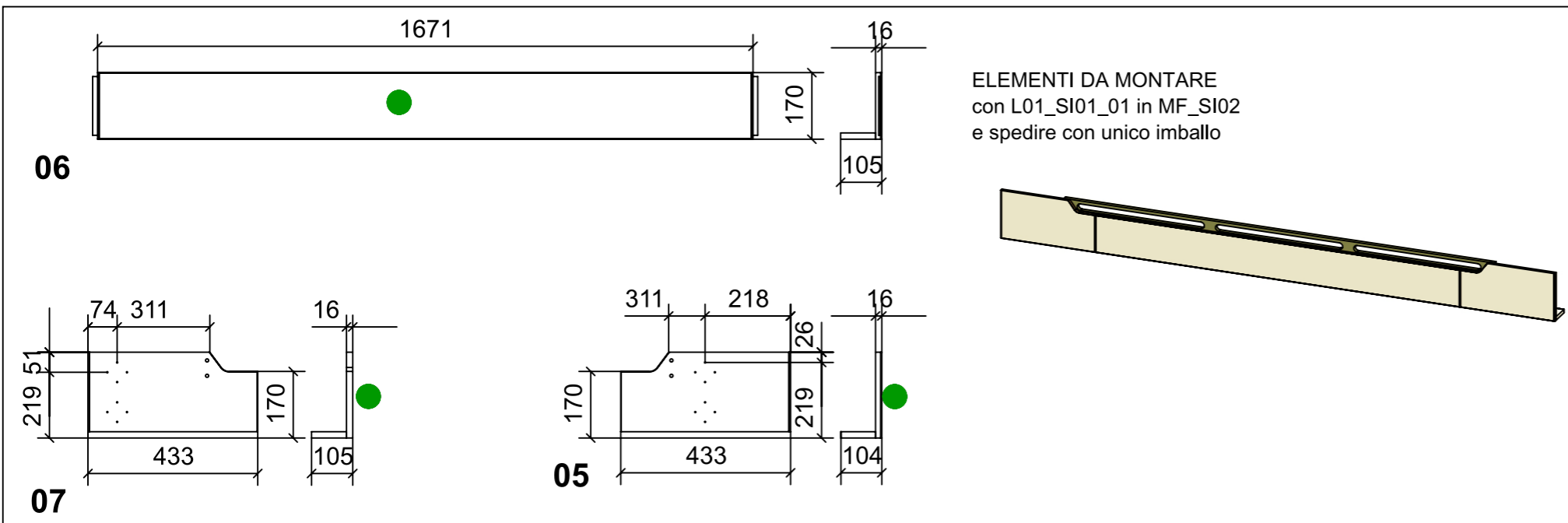

VERNICIATURA LASTRA/LACCATI:  
● = VERNICIARE 1 LATO + FILI RASATI O BORDATI  
 NESSUN SIMBOLO = VERNICIARE 2 LATI + FILI RASATI O BORDATI

LOCALE	CODICE	DESCRIZIONE COMPONENTE	FINITURA	GR.
SALONE	MD320_R01_SM01	MOBILE COLONNA SX POPPA	LASTRA SCURA	4

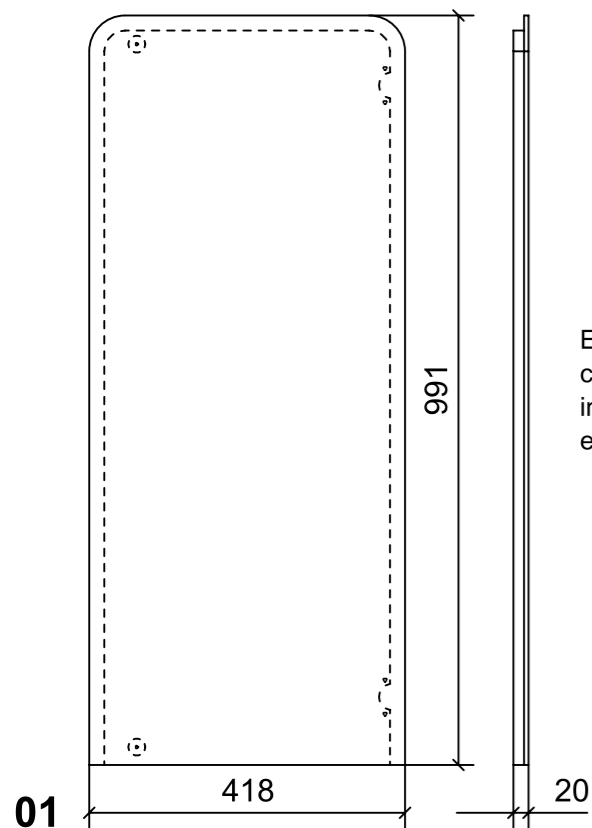

ELEMENTO DA MONTARE  
 con L01\_SM01\_01-02-03; A32\_SM01\_01  
 in MF\_SM01  
 e spedire con unico imballo

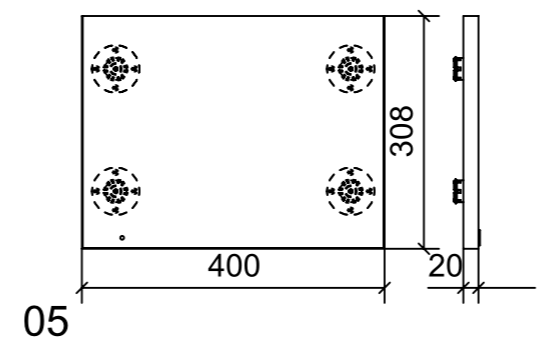
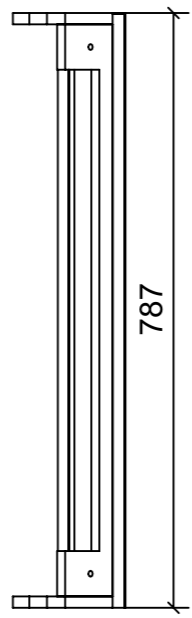
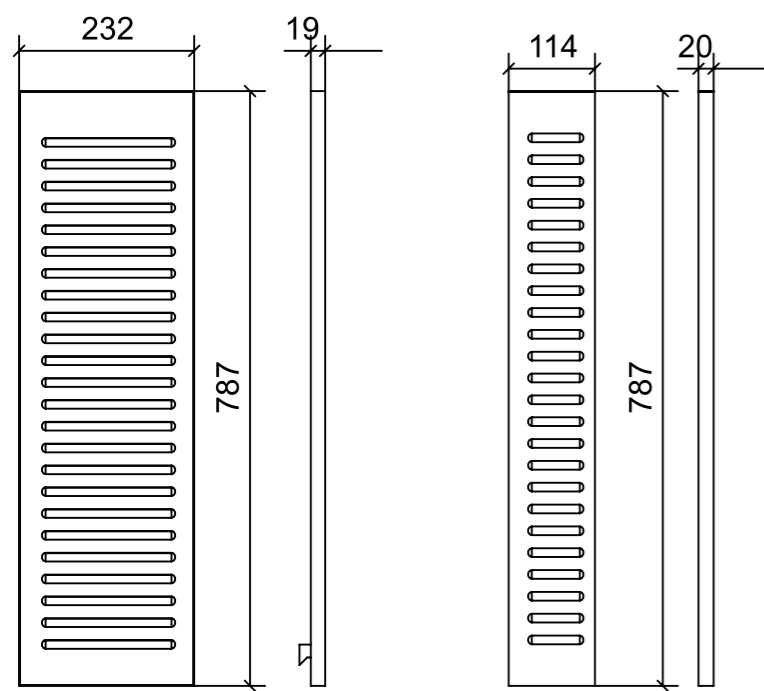
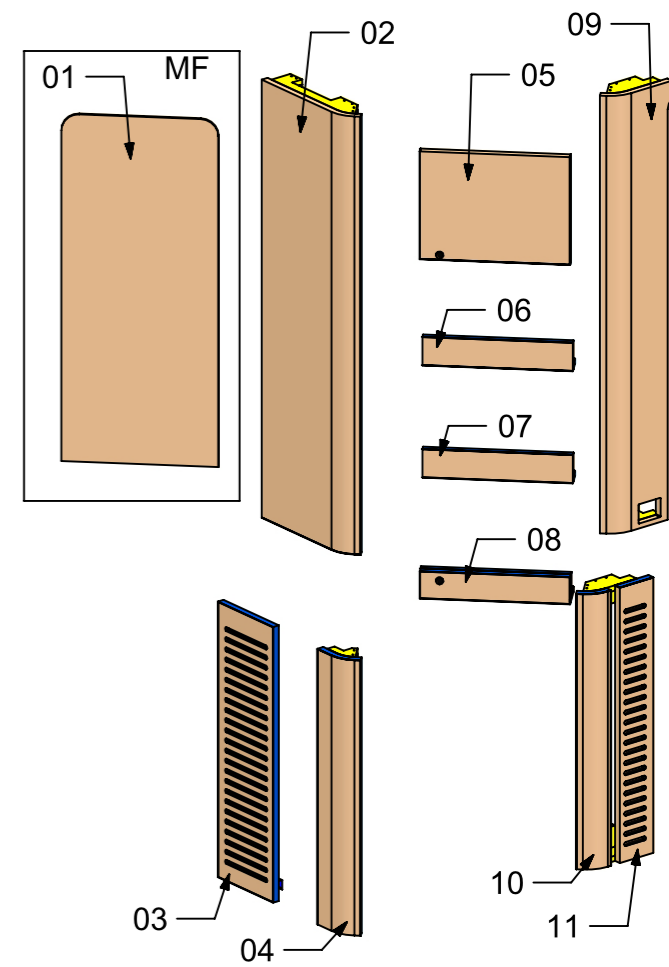
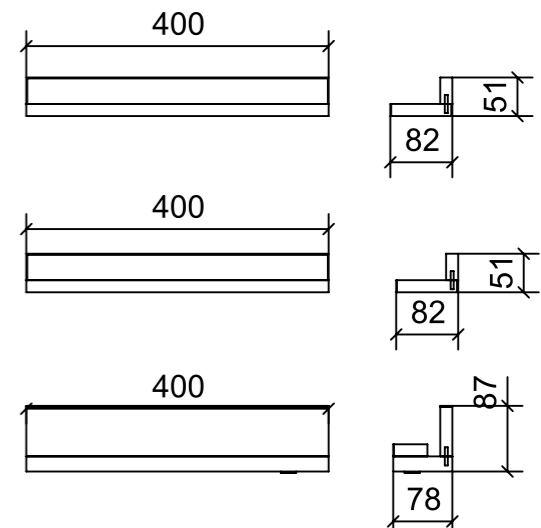
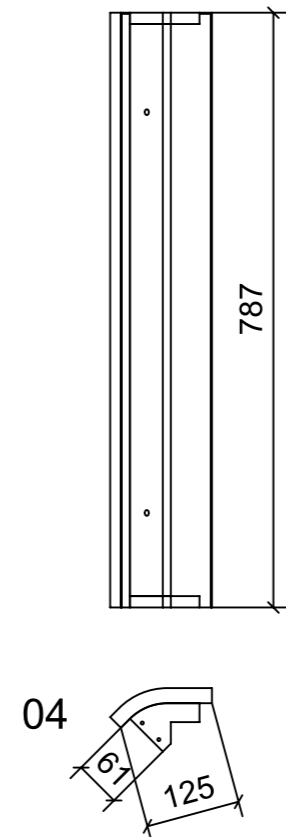
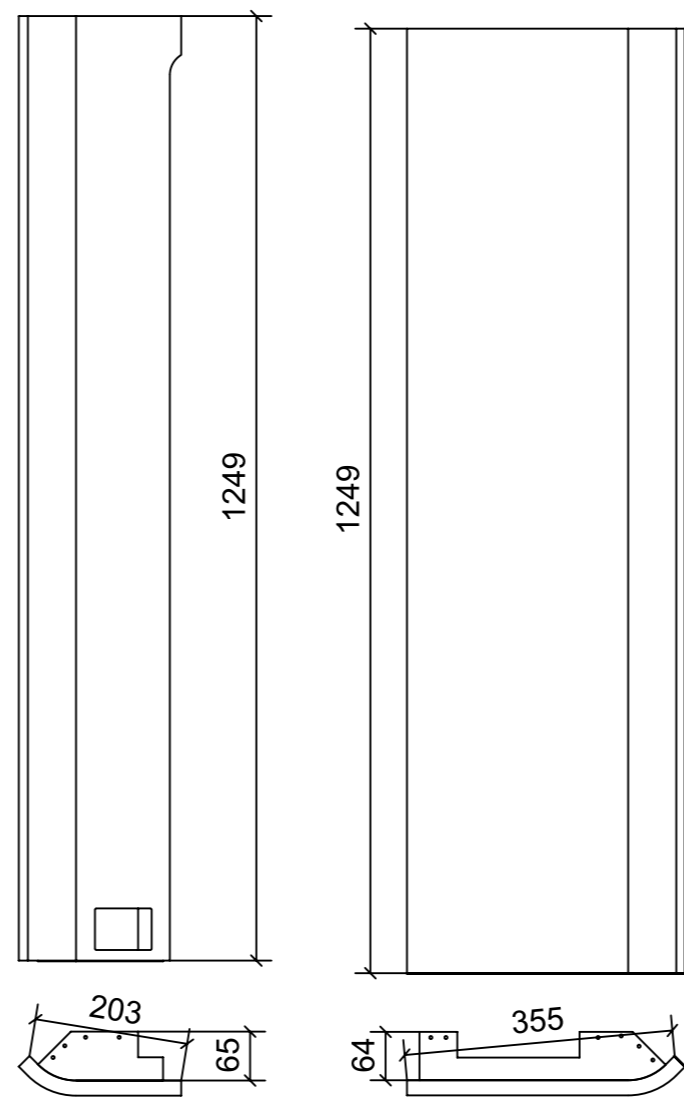
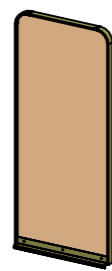

03

11

10

09

02

05

04

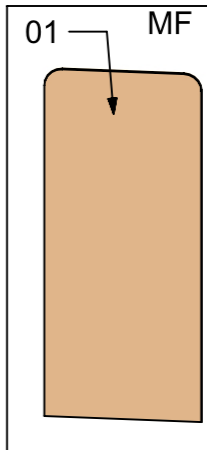

02

09

05

06

07

08

10

11

FERRAMENTA	QTY
MAGNETE FORZA MAGNETICA1-5 10KG_HAFELE_246.87.112	2
RISCONTRO IN FERRO PER CALAMITA TONDO	2
BUSSOLA 6MA X 10 FORO DIAM.8	19
FITLOCK M_MASCHERPA_3MM_6020202101	8
RISCONTRO IN FERRO PER CALAMITA DA FAR PRODURRE	2
VITE 6MA X 25 TESTA BOMBATA NERA BHCS 10.9 ISO 7380	2

VERNICIATURA LASTRA/LACCATI: ● = VERNICIARE 1 LATO + FILI RASATI O BORDATI    NESSUN SIMBOLO = VERNICIARE 2 LATI + FILI RASATI O BORDATI

LOCALE	CODICE	DESCRIZIONE COMPONENTE	FINITURA	GR.
SALONE	MD320_R01_SO01	COMODINO SX CENTRONAVE	LASTRA SCURA	3

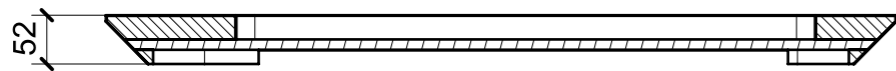

SECTION U-U

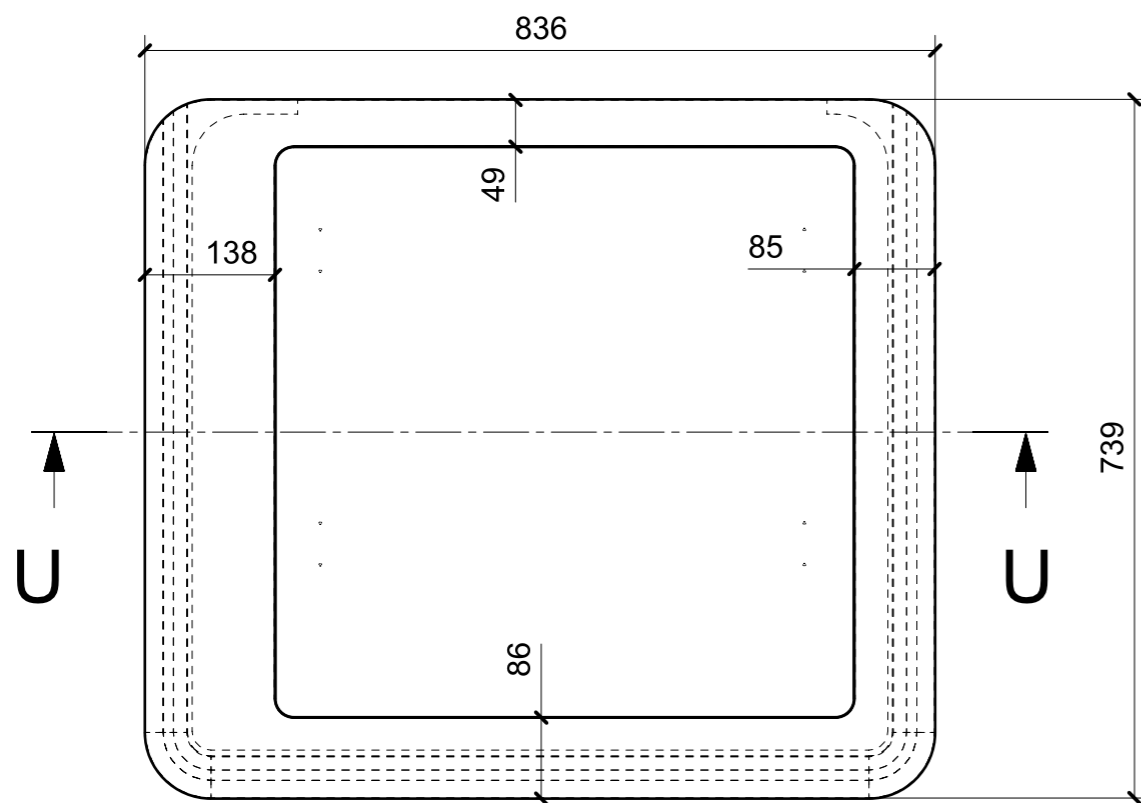

01

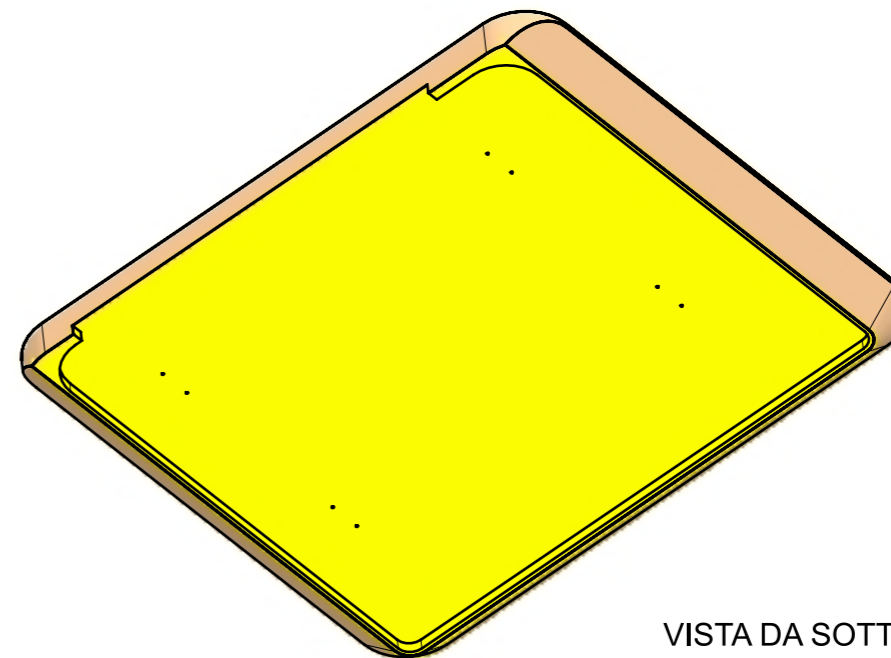

VISTA DA SOTTO

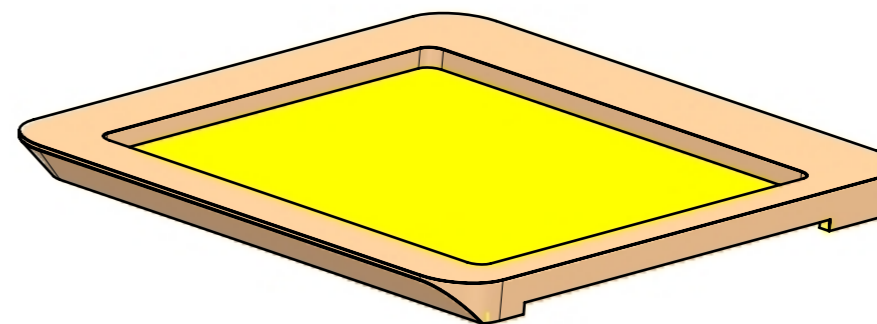

VERNICIATURA LASTRA/LACCATI:

● = VERNICIARE 1 LATO + FILI RASATI O BORDATI

NESSUN SIMBOLO = VERNICIARE 2 LATI + FILI RASATI O BORDATI

LOCALE	CODICE	DESCRIZIONE COMPONENTE	FINITURA	GR.
SALONE	MD320_R02_SO01	COMODINO SX CENTRONAVE	LASTRA CHIARA	3

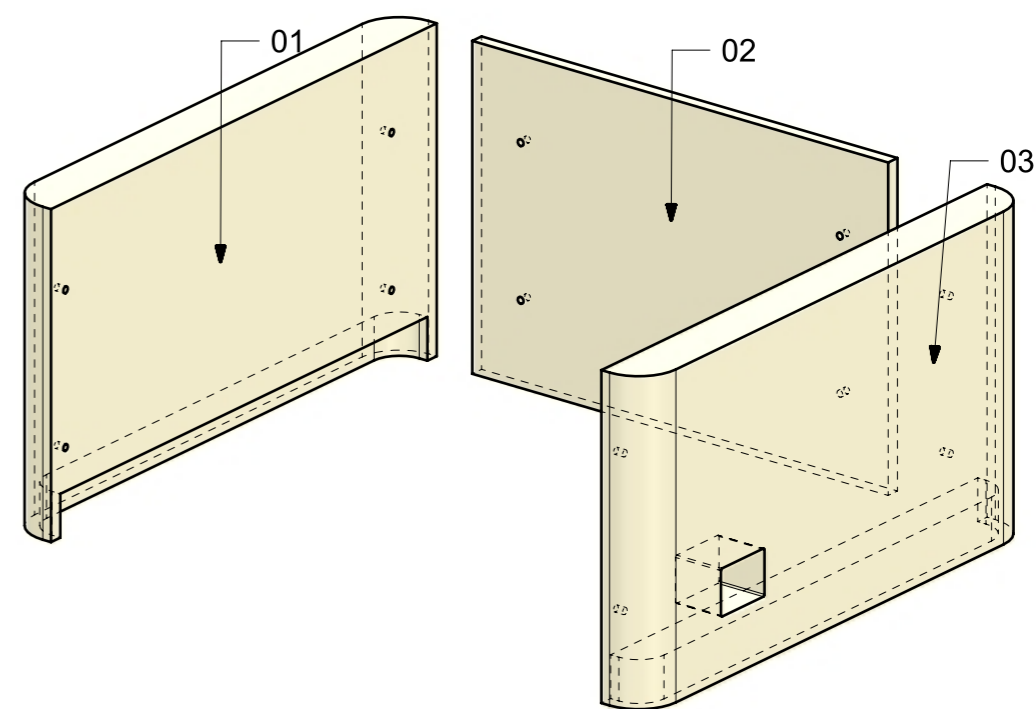
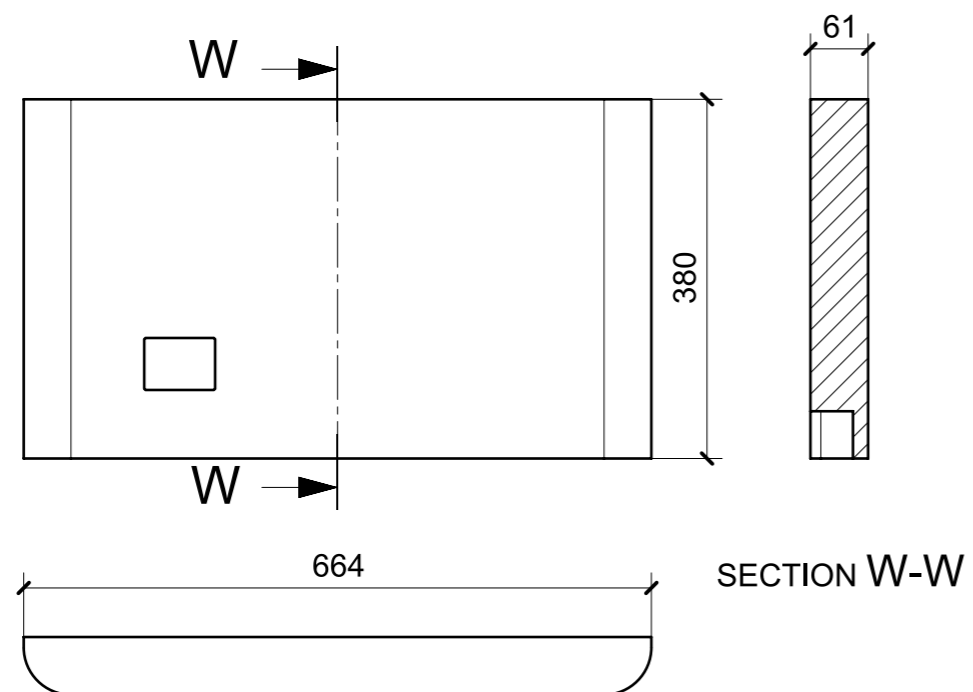
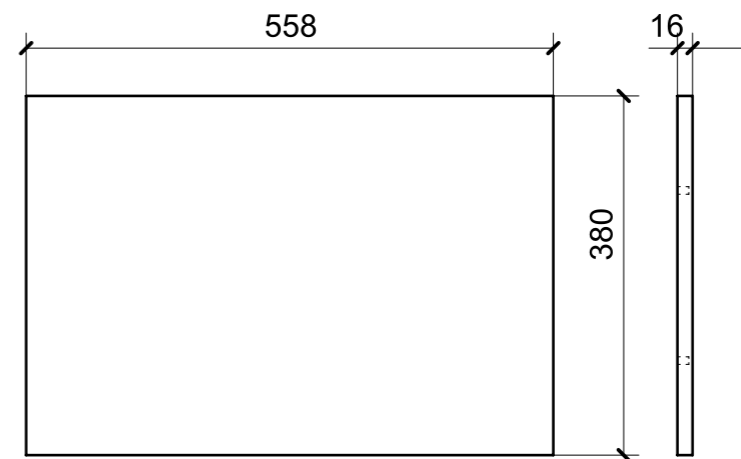
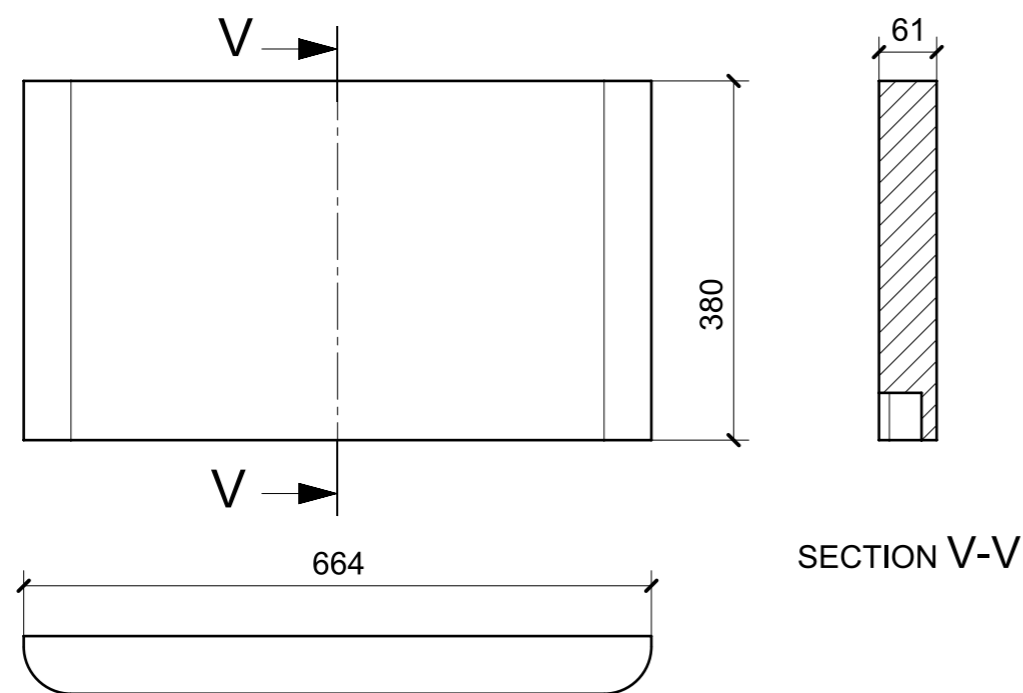

FERRAMENTA	QTY
BUSSOLA 6MA X 10 FORO DIAM.8	12

VERNICIATURA LASTRA/LACCATI:

● = VERNICIARE 1 LATO + FILI RASATI O BORDATI

NESSUN SIMBOLO = VERNICIARE 2 LATI + FILI RASATI O BORDATI

LOCALE	CODICE	DESCRIZIONE COMPONENTE	FINITURA	GR.
SALONE	MD320_R01_SP01	STRUTTURA INGRESSO DX POPPA	LASTRA SCURA	3

ELEMENTO DA MONTARE  
in MF\_SP01  
e spedire con unico imballo

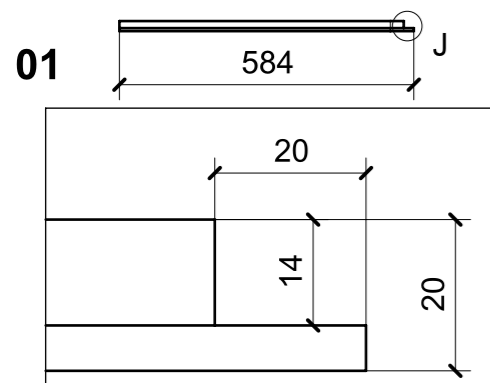
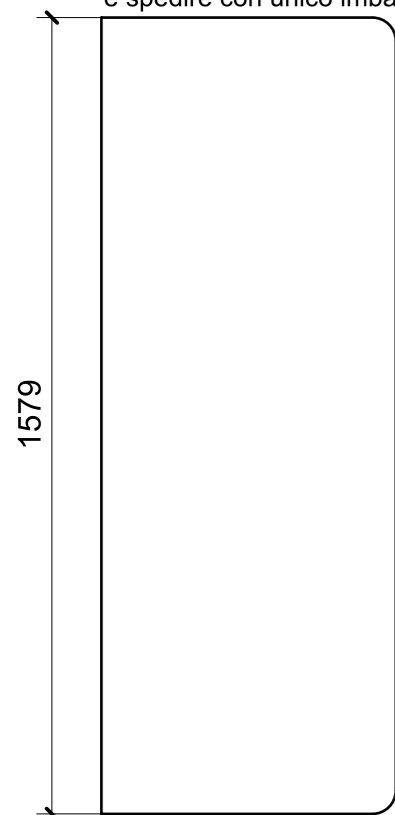

DETAIL J  
SCALE 1:1

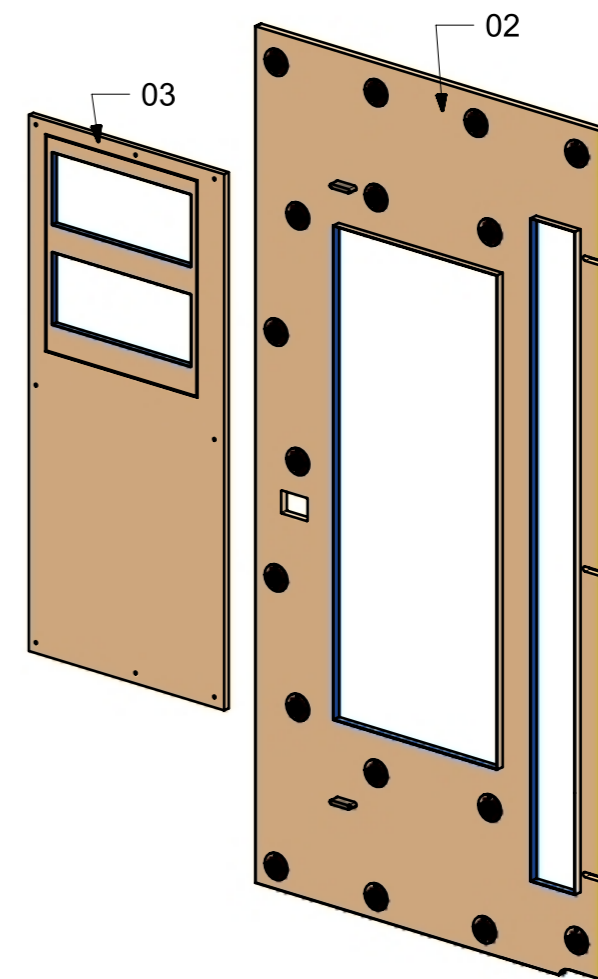
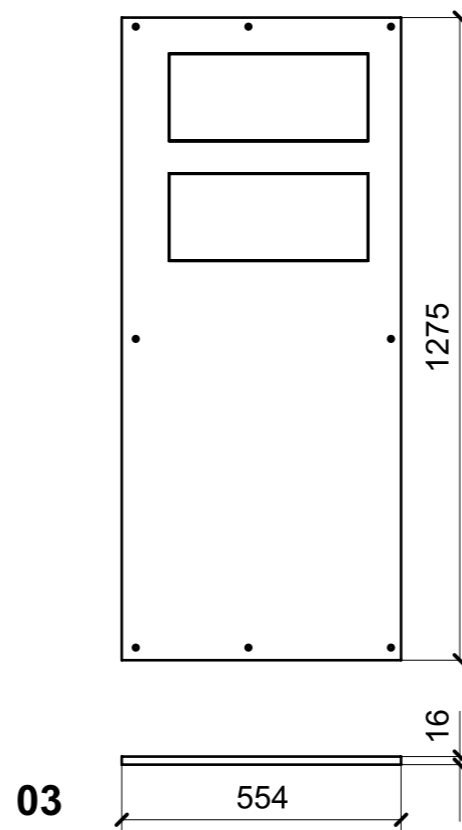
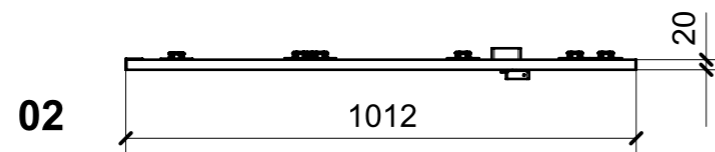
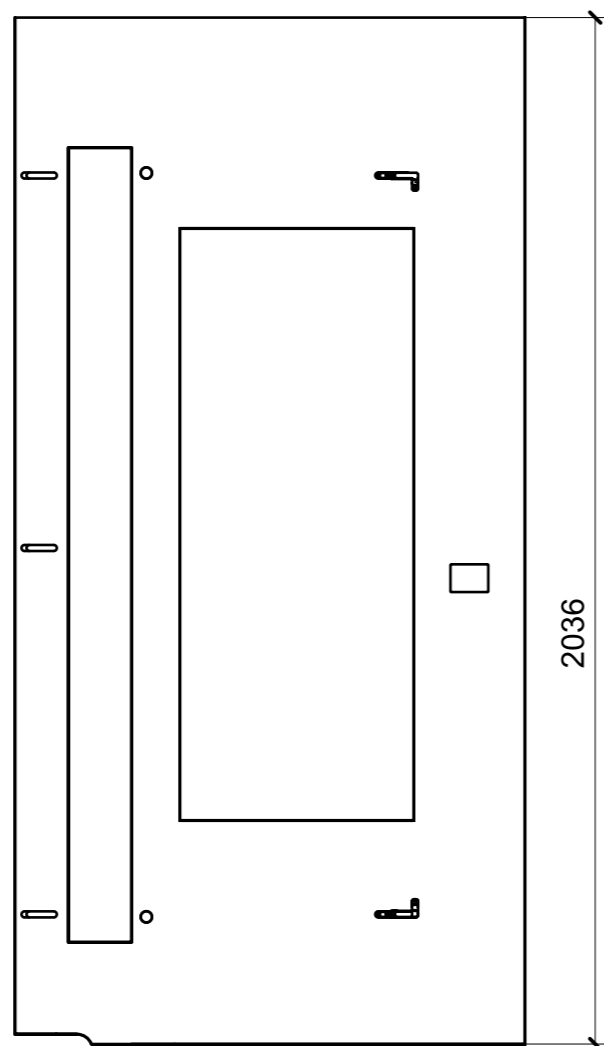

ELEMENTO DA MONTARE  
in MF\_SP01  
e spedire con unico imballo

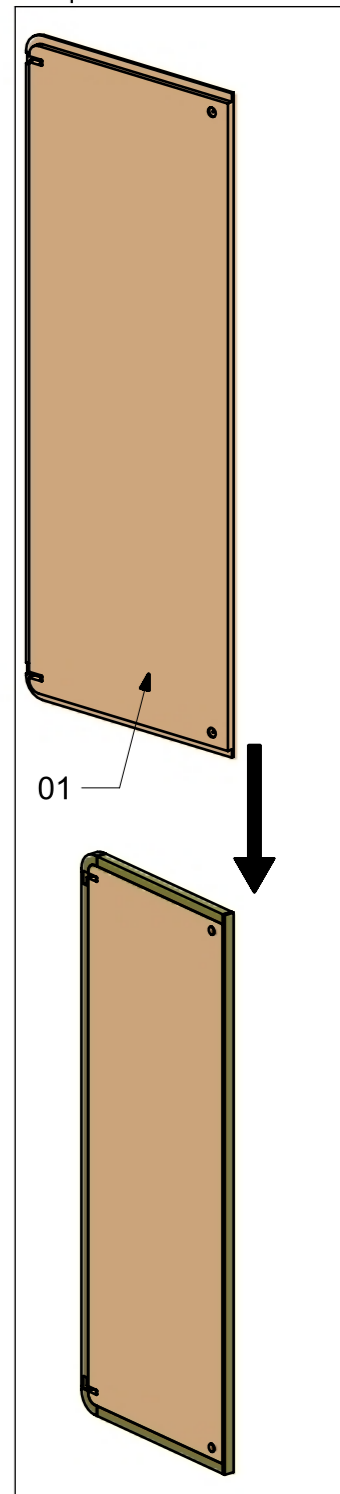

FERRAMENTA	QTY
FITLOCK M_MASCHERPA_3MM_6020202101	62
CERNIERA DUOMATIC DX AIR 105° PREMIUM_HAFELE_329_97_530	1
CERNIERA DUOMATIC SX AIR 105° PREMIUM_HAFELE_329_97_530	1
MAGNETE FORZA MAGNETICA1-5 10KG_HAFELE_246.87.112	4

VERNICIATURA LASTRA/LACCATI:

● = VERNICIARE 1 LATO + FILI RASATI O BORDATI

NESSUN SIMBOLO = VERNICIARE 2 LATI + FILI RASATI O BORDATI

<b>LOCALE</b>	<b>CODICE</b>	<b>DESCRIZIONE COMPONENTE</b>	<b>FINITURA</b>	<b>GR.</b>
SALONE	MD320_R01_SQ01	MOBILE CURVO INGRESSO DX POPPA	LASTRA SCURA	4

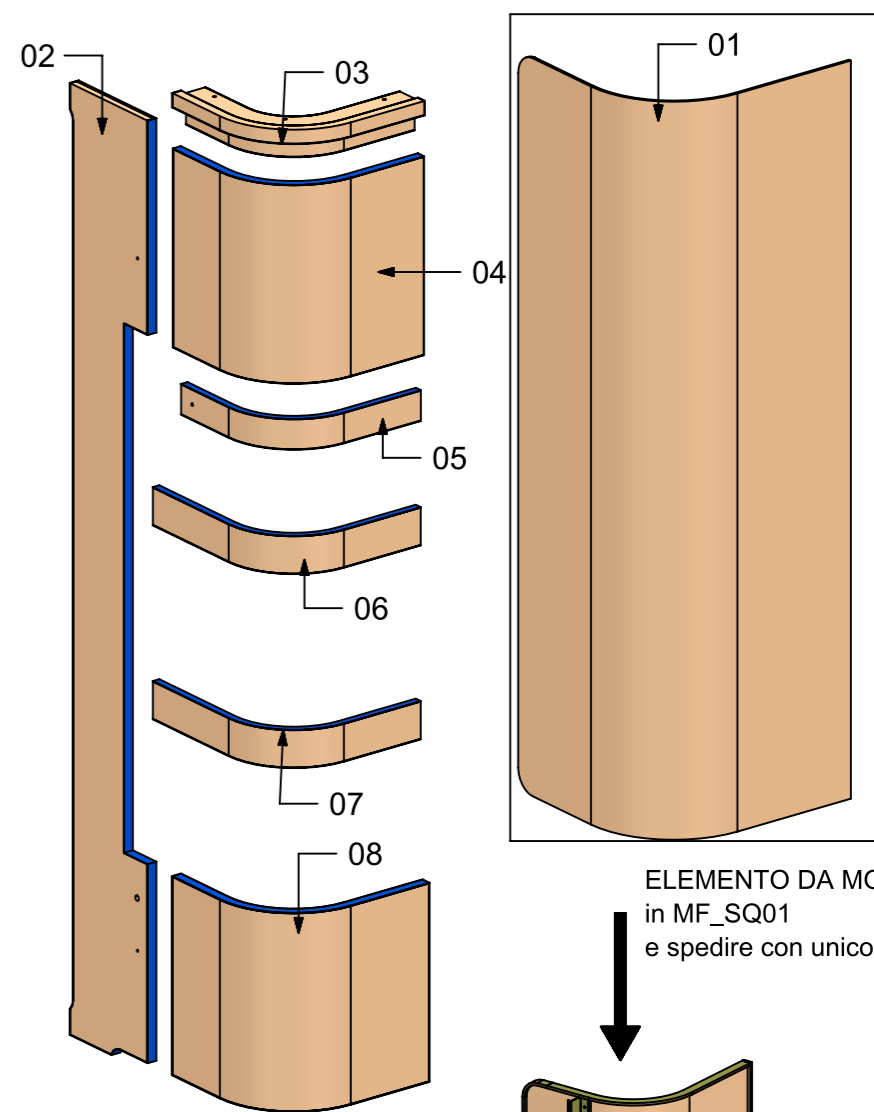
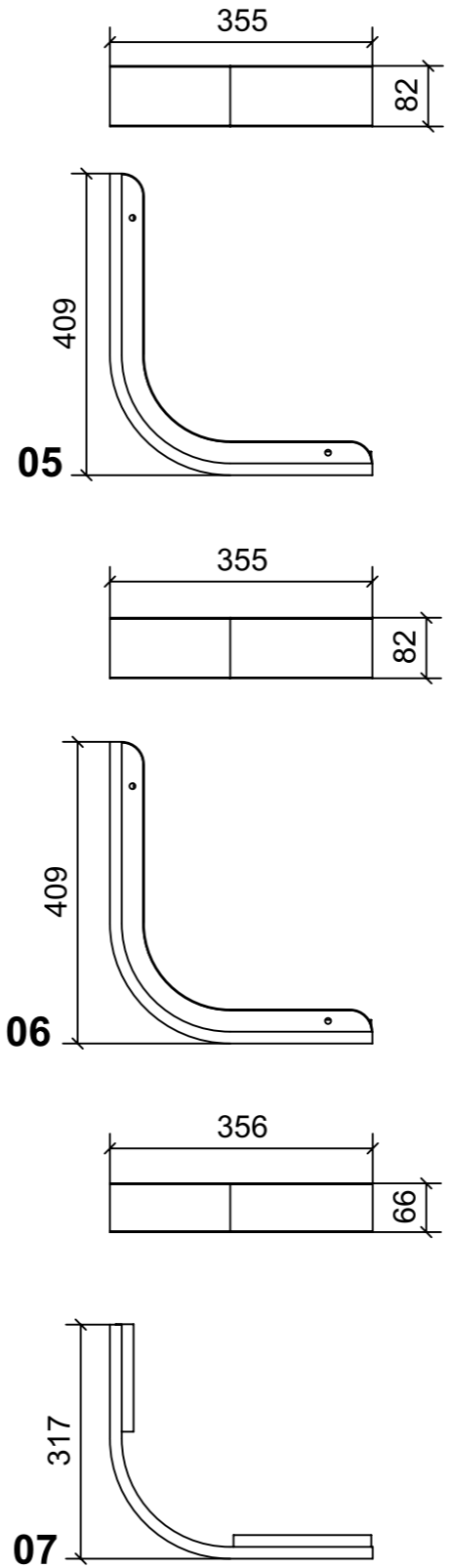
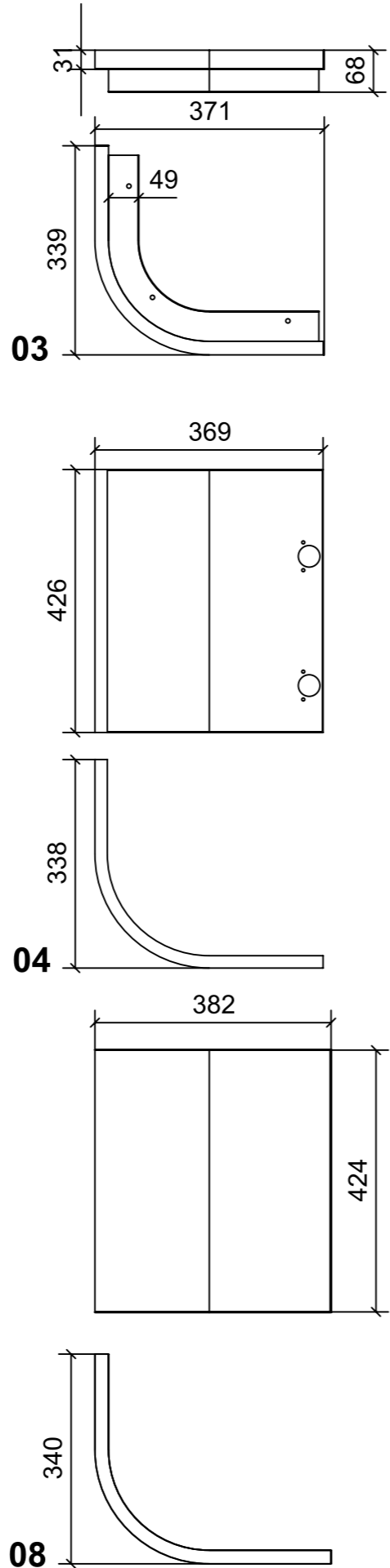
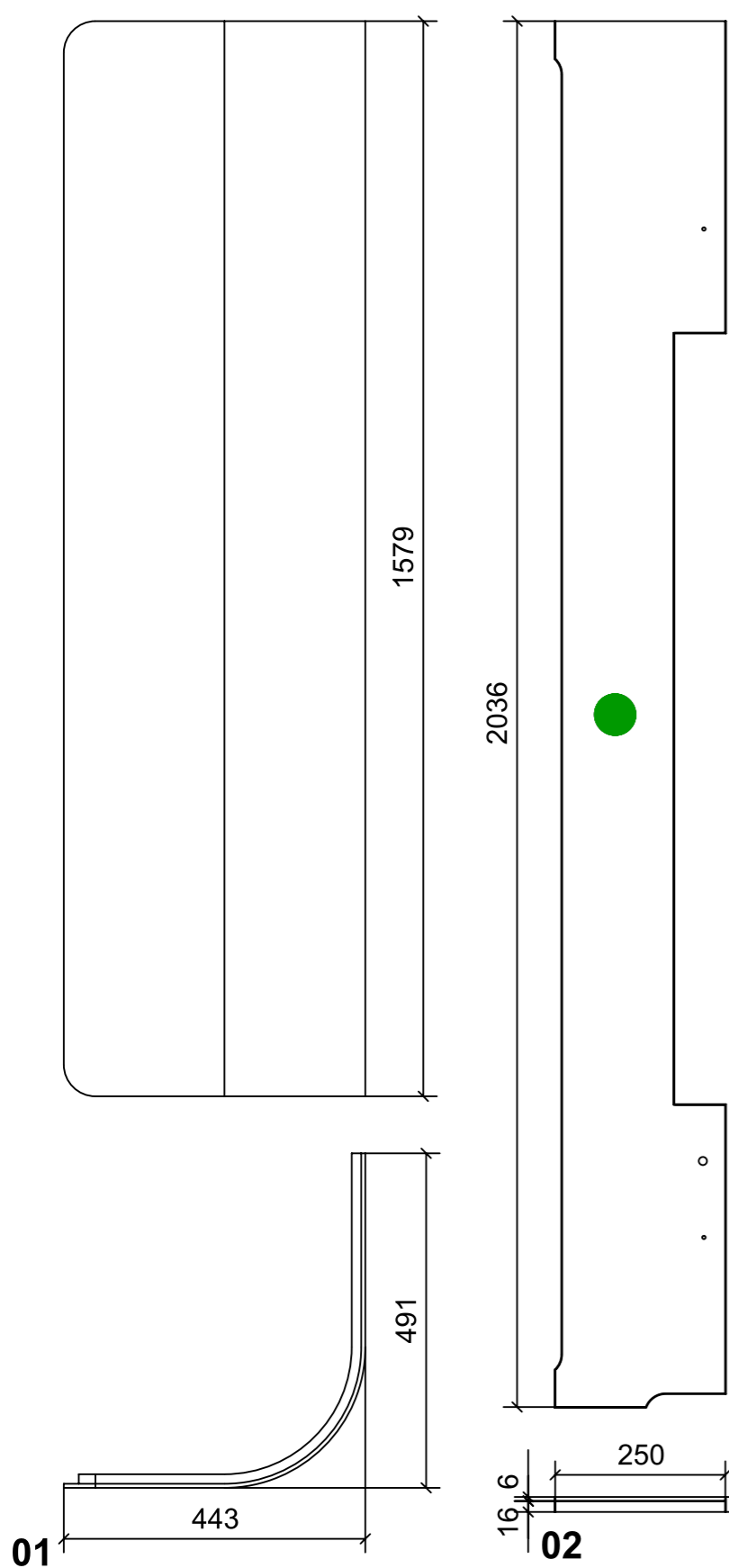

ELEMENTO DA MONTARE  
in MF\_SQ01  
e spedire con unico imballo

FERRAMENTA	QTY
RISCONTRO IN FERRO PER CALAMITA TONDO	3
BUSSOLA 5MA ANKOR BORGHIS X CERNIERA COLLO PIENO	4
BUSSOLA 6MA X 10 FORO DIAM.8	14
MAGNETE FORZA MAGNETICA1-5 10KG_HAFELE_246.87.112	5

VERNICIATURA LASTRA/LACCATI:  
● = VERNICIARE 1 LATO + FILI RASATI O BORDATI      NESSUN SIMBOLO = VERNICIARE 2 LATI + FILI RASATI O BORDATI

LOCALE	CODICE	DESCRIZIONE COMPONENTE	FINITURA	GR.
SALONE	MD320_R01_SR01	STRUTTURA E RIV. PARETE PRUA	EULITE LASTRA SCURA	2

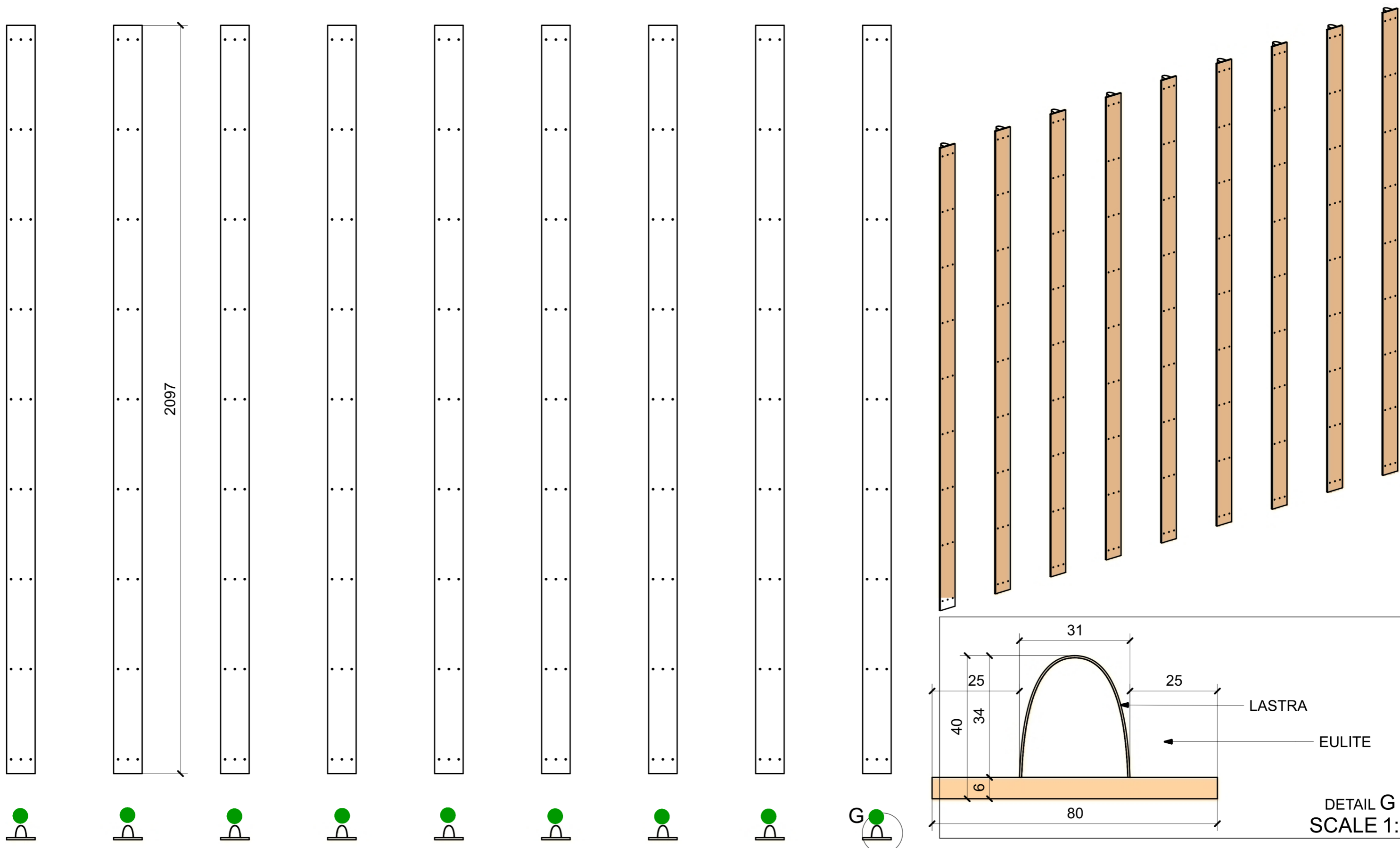

VERNICIATURA LASTRA/LACCATI:

● = VERNICIARE 1 LATO + FILI RASATI O BORDATI

NESSUN SIMBOLO = VERNICIARE 2 LATI + FILI RASATI O BORDATI

DETAIL G  
SCALE 1:1

LOCALE	CODICE	DESCRIZIONE COMPONENTE	FINITURA	GR.
SALONE	MD320_R01_SS01	CIELINO PRUA	LASTRA SCURA	3

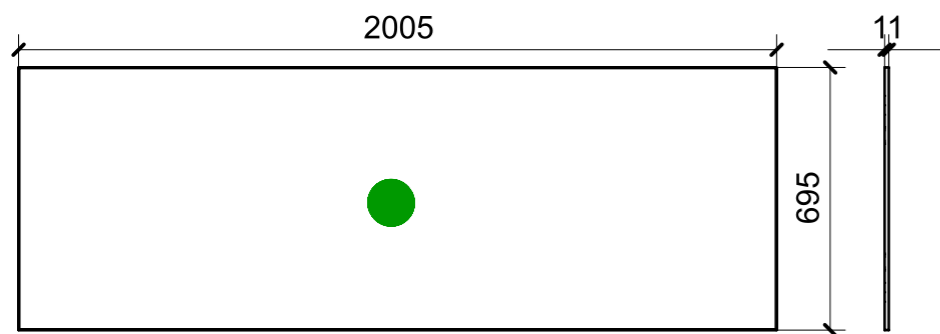
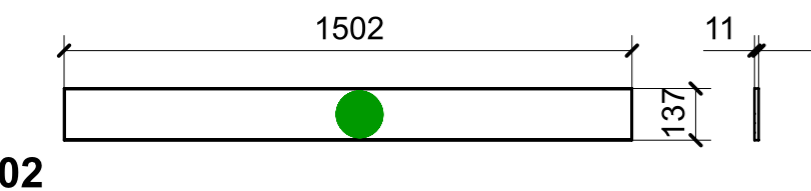
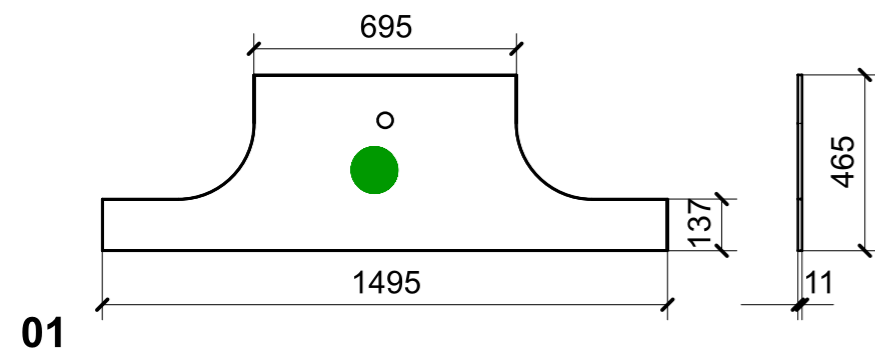

03

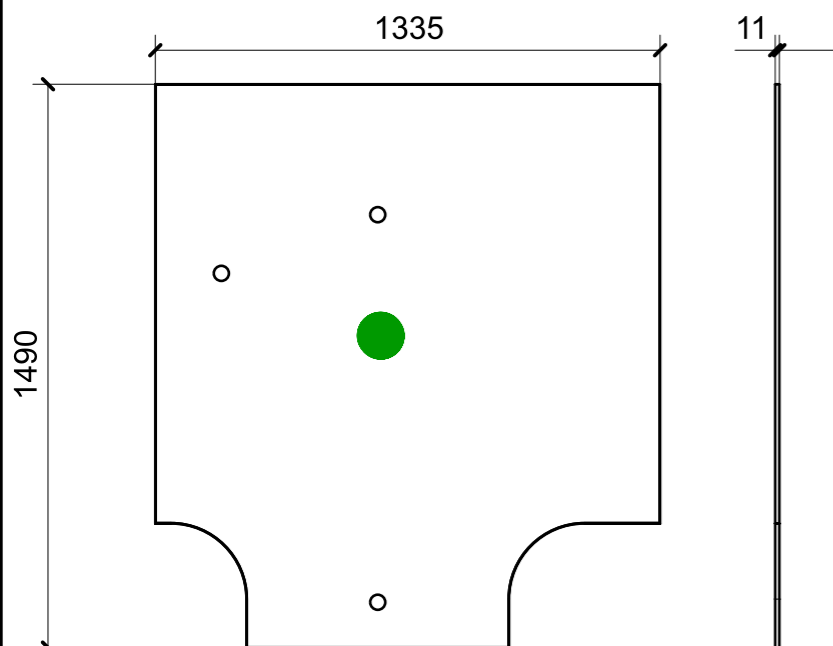

04

INCOLLARE I TONDINI ALLE LASTRE

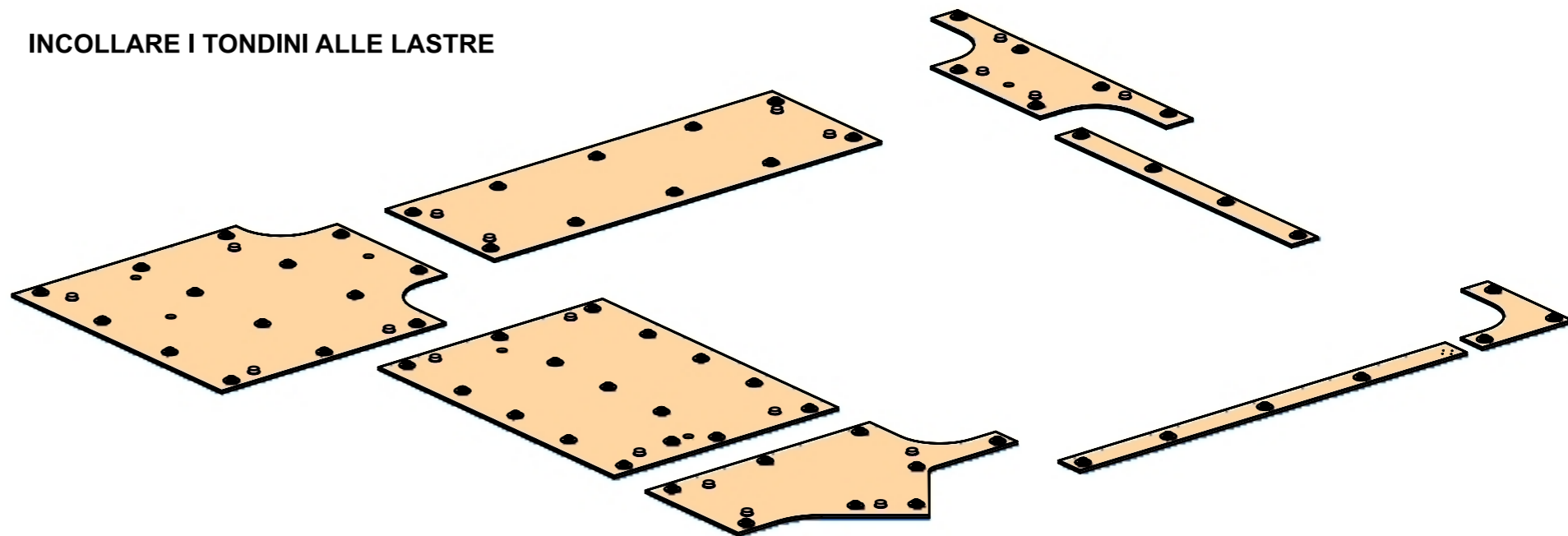

FERRAMENTA	QTY
TONDINO PER CENTRAGGIO ANTICADUTA 40X15	20
FITLOCK M_MASCHERPA_3MM_6020202101	65

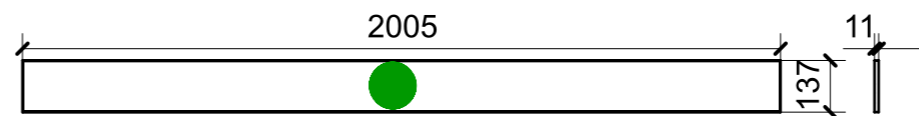

07

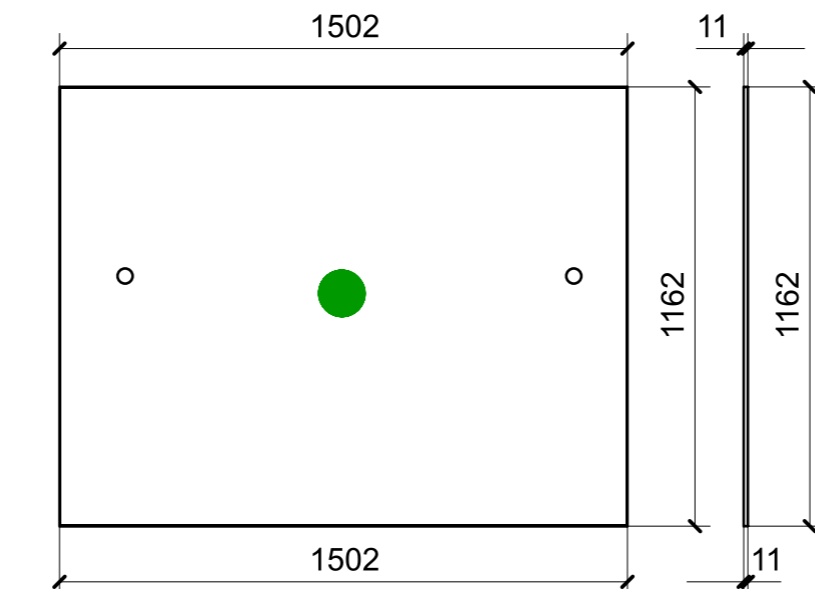

05

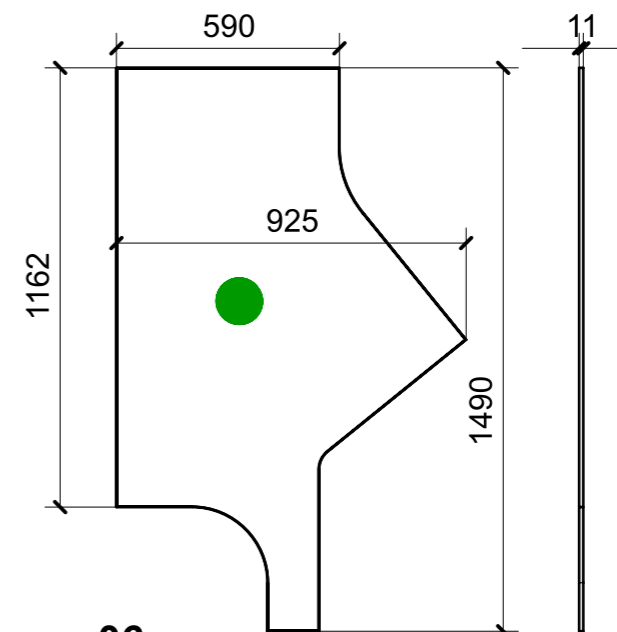

06

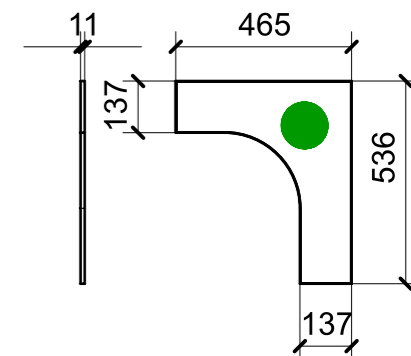

08

VERNICIATURA LASTRA/LACCATI:

● = VERNICIARE 1 LATO + FILI RASATI O BORDATI

NESSUN SIMBOLO = VERNICIARE 2 LATI + FILI RASATI O BORDATI

LOCALE	CODICE	DESCRIZIONE COMPONENTE	FINITURA	GR.
SALONE	MD320_R01_ST01	CIELINO POPPA	LASTRA SCURA	4

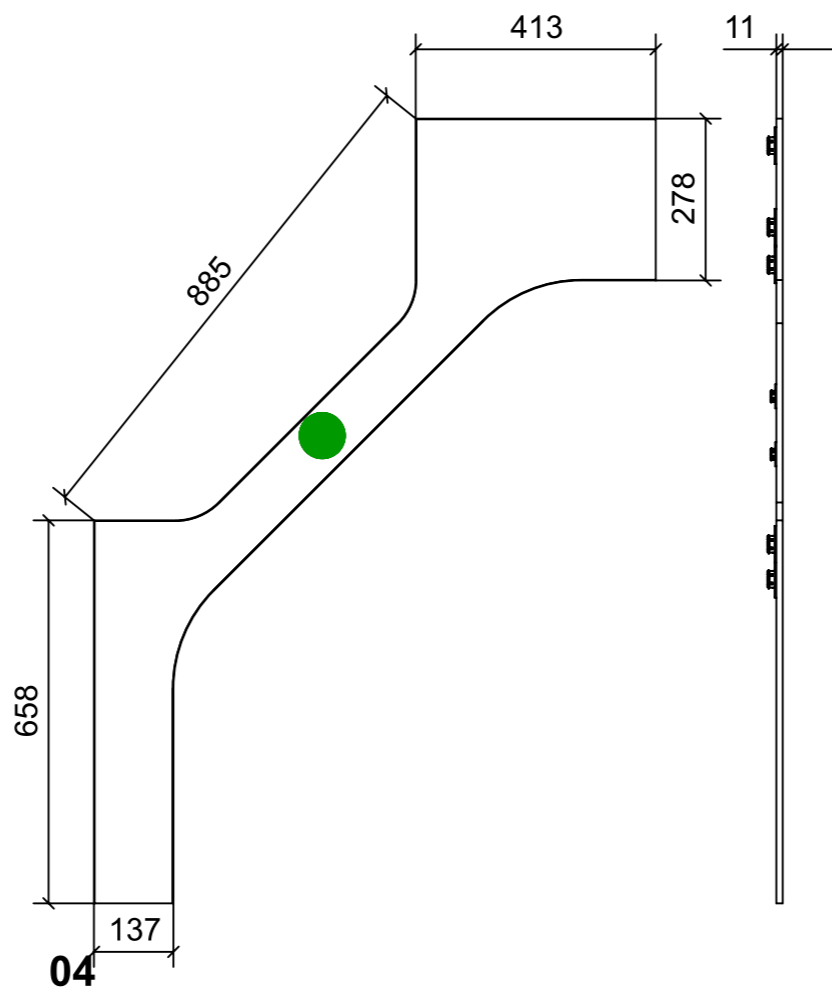
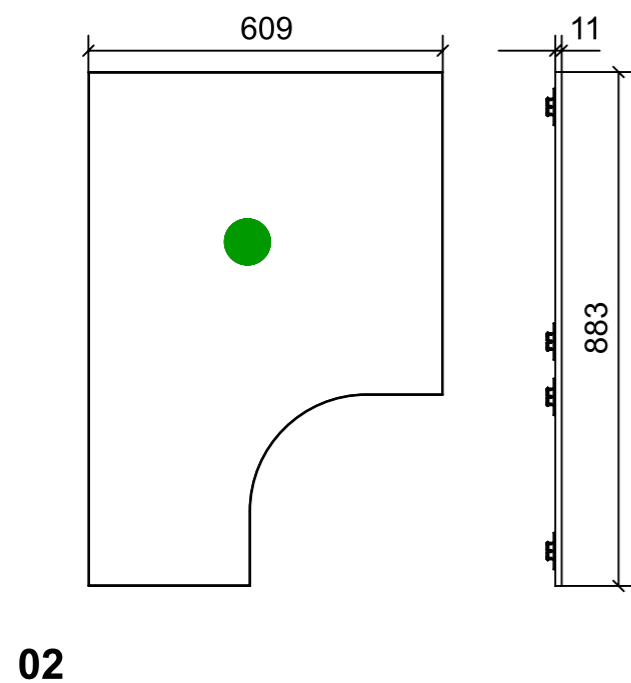
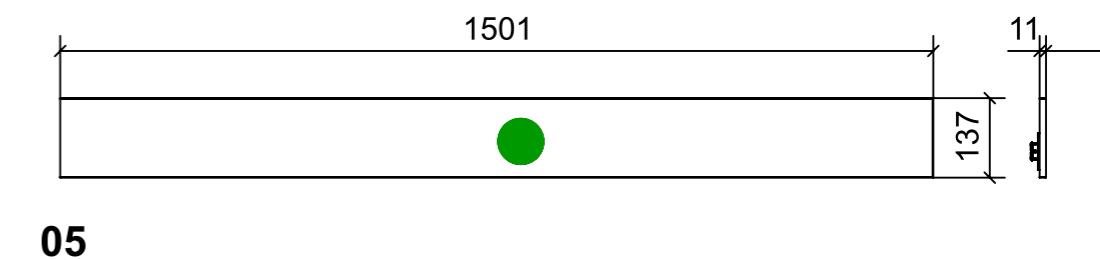
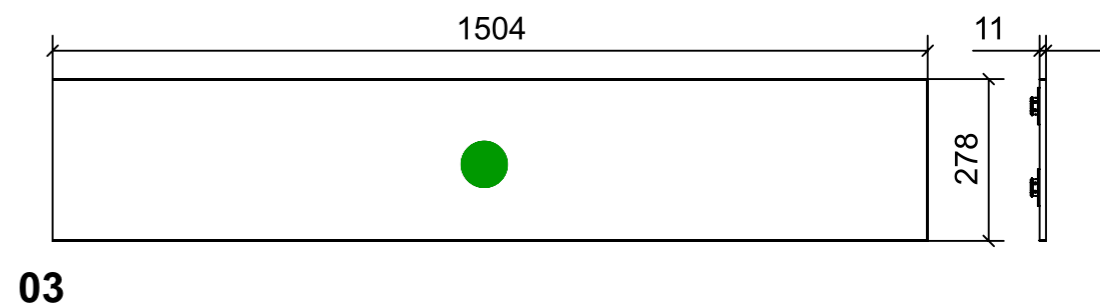
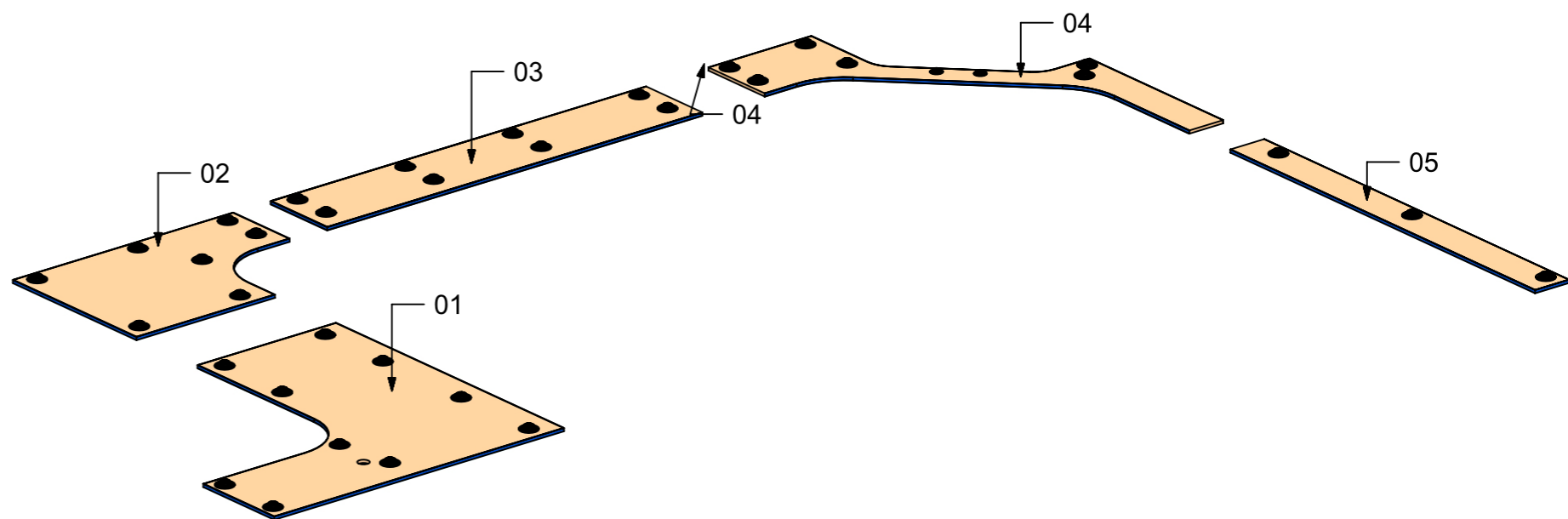
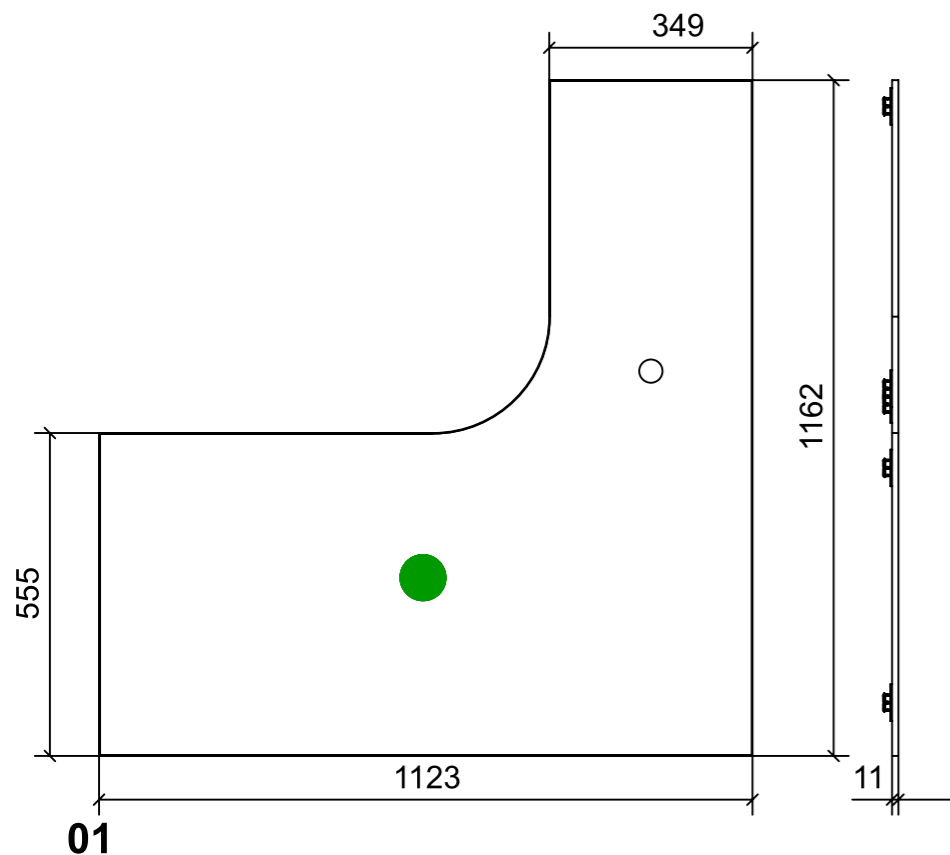

FERRAMENTA	QTY
FITLOCK M_MINI	2
FITLOCK M_MASCHERPA_3MM_6020202101	34

VERNICIATURA LASTRA/LACCATI:

● = VERNICIARE 1 LATO + FILI RASATI O BORDATI

NESSUN SIMBOLO = VERNICIARE 2 LATI + FILI RASATI O BORDATI

LOCALE	CODICE	DESCRIZIONE COMPONENTE	FINITURA	GR.
SALONE	MD320_R01_SU01	CIELINO ZONA TV A DISCESA	LASTRA SCURA	3

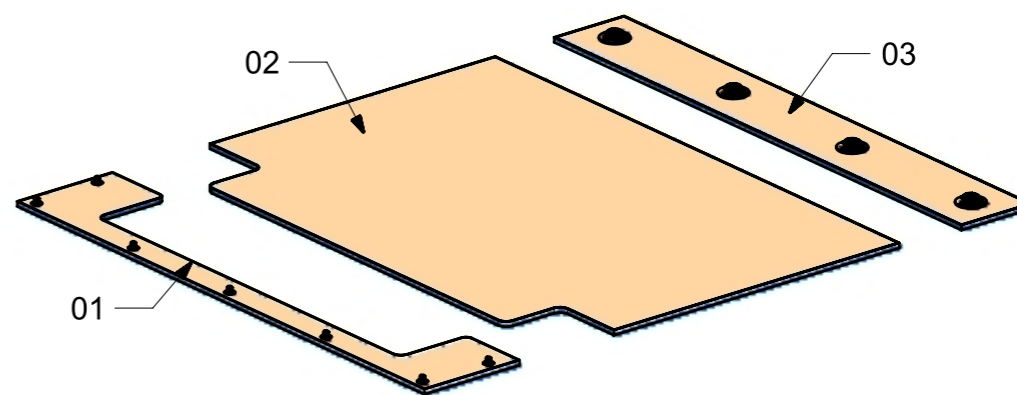
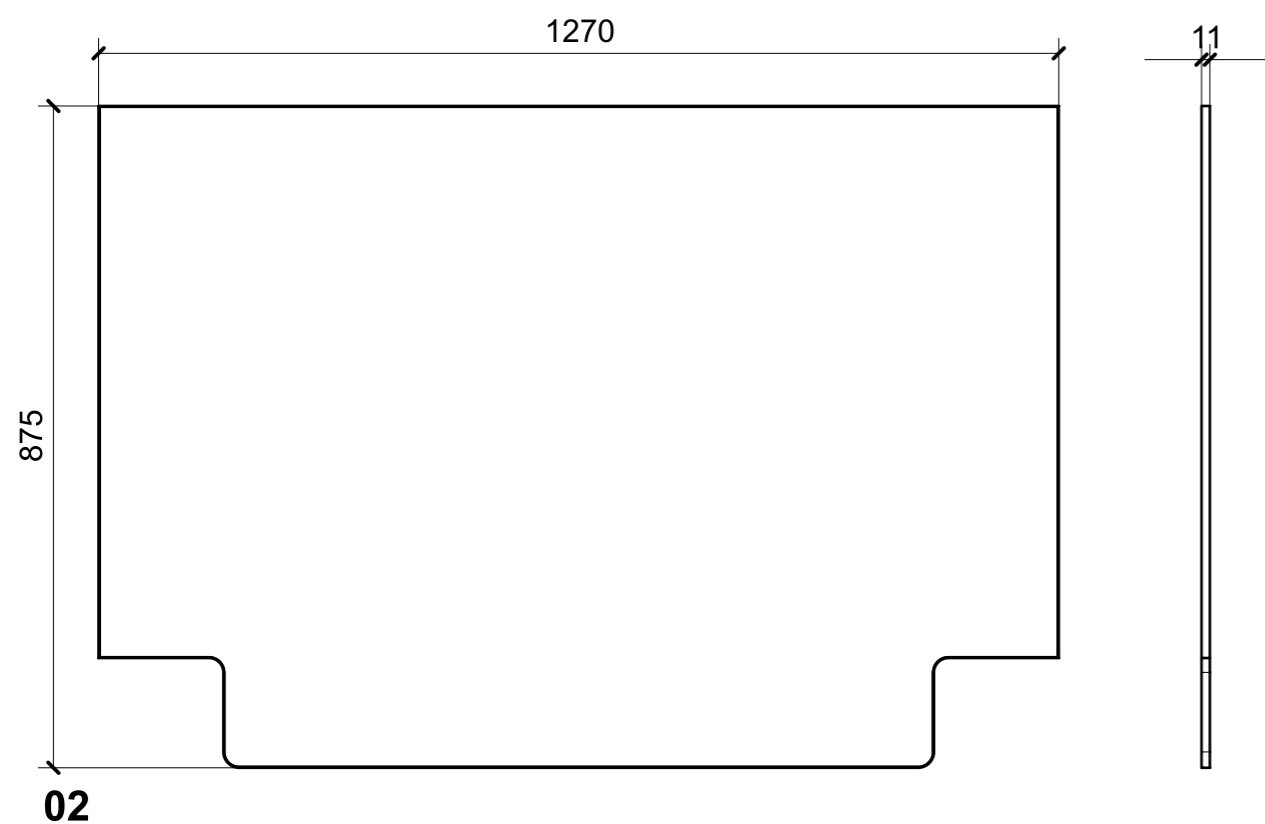
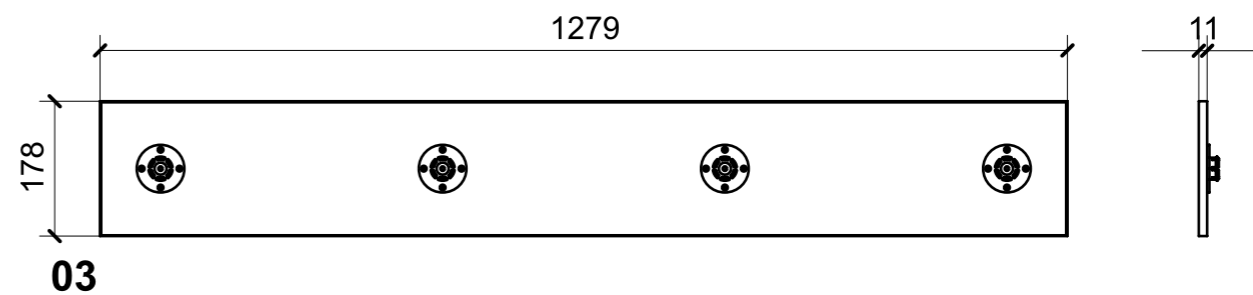
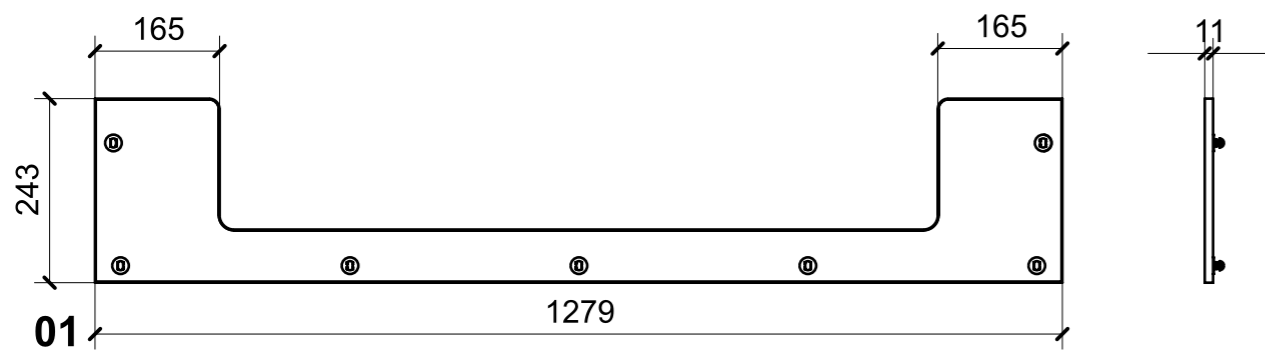

FERRAMENTA	QTY
MS INCASSO_ITALVIPLA_972_FMPC_M1B	7
FITLOCK M_MASCHERPA_3MM_6020202101	4

VERNICIATURA LASTRA/LACCATI:

● = VERNICIARE 1 LATO + FILI RASATI O BORDATI

NESSUN SIMBOLO = VERNICIARE 2 LATI + FILI RASATI O BORDATI

LOCALE	CODICE	DESCRIZIONE COMPONENTE	FINITURA	GR
SALONE	MD320_R01_SV01	VANO TENDA INGRESSO SALONE	LASTRA SCURA	PTP

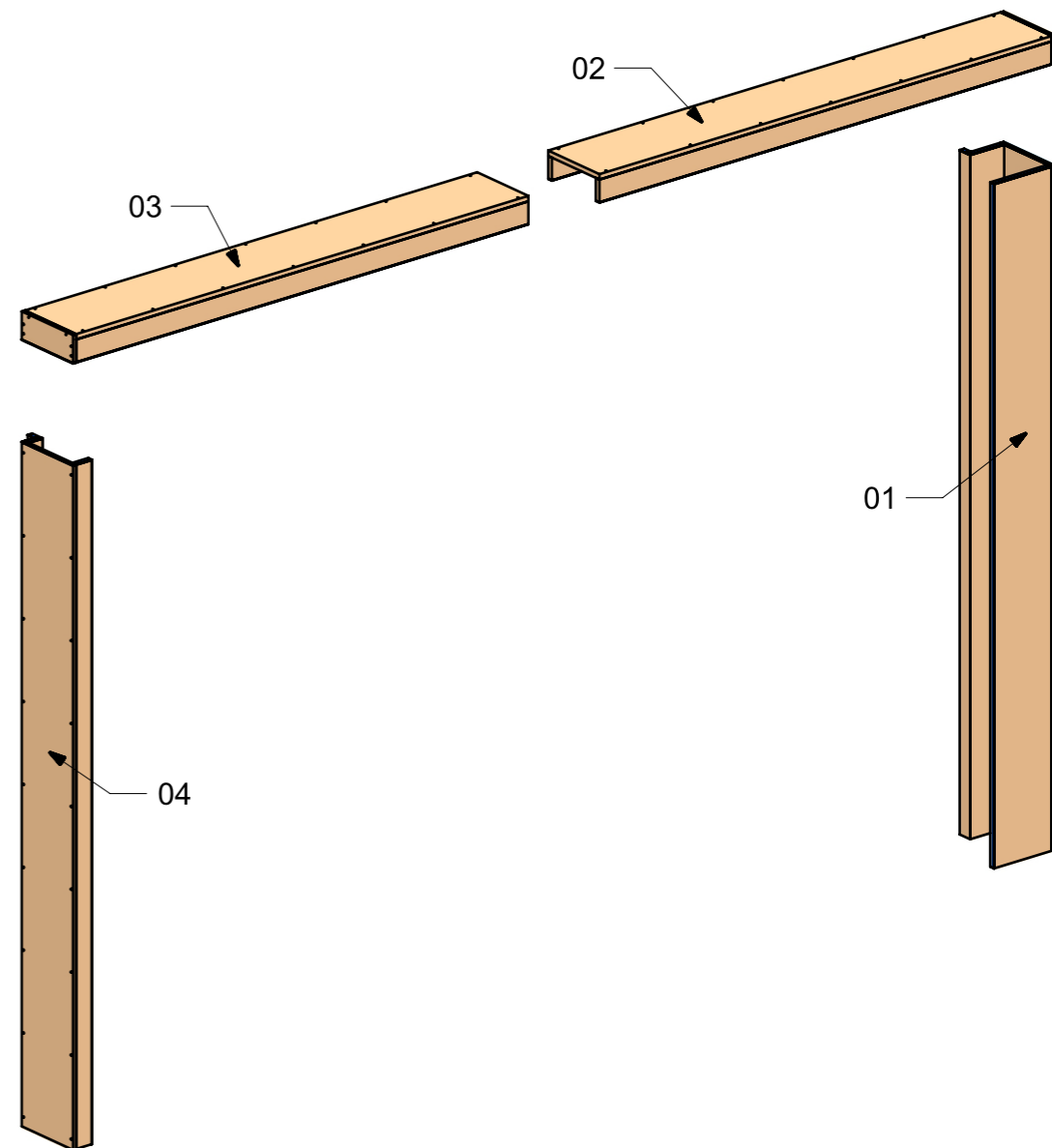
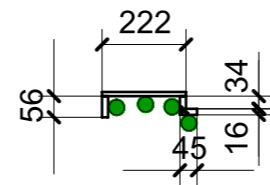
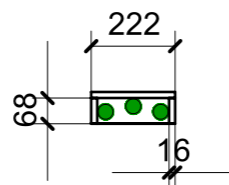
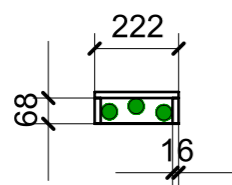
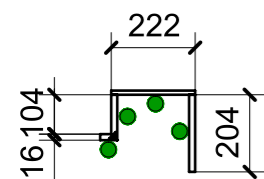
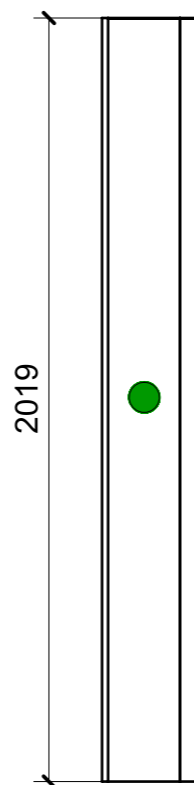
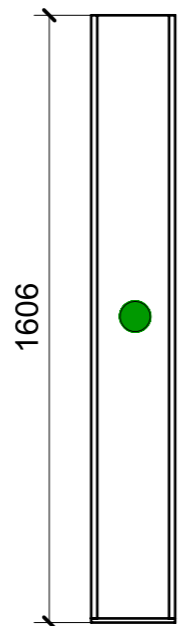
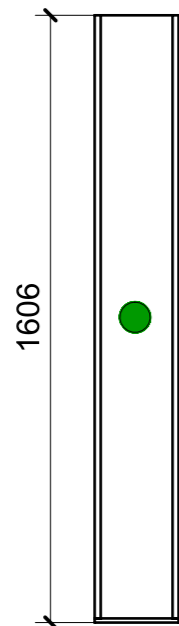
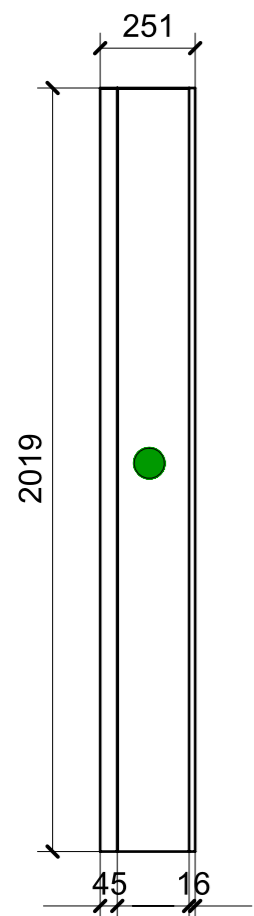

VERNICIATURA LASTRA/LACCATI:

● = FILI RASATI

● = VERNICIARE 1 LATO + FILI RASATI O BORDATI

NESSUN SIMBOLO = VERNICIARE 2 LATI + FILI RASATI O BORDATI