

LOCALE	CODICE	DESCRIZIONE COMPONENTE	FINITURA	Q.TA
CABINA OSPITI DX	MD299_MG_RA02	ARMADIO	LASTRA SCURA	1

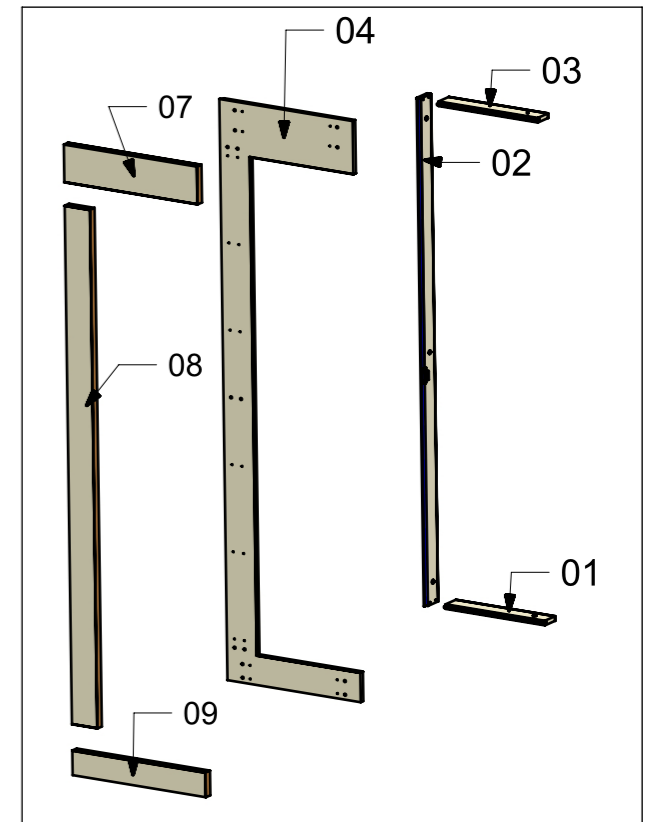

FERRAMENTA	QTY
VITE 5MA X 25 TESTA BOMBATA	5
PLACCHETTA COUNTER STEEL_TECHNOPARTNER_MC-JM49	1
CALAMITA SEALED MAGNETIC_TECNOPARTNER_MC-JM50-BL	1

LOCALE	CODICE	DESCRIZIONE COMPONENTE	FINITURA	Q.TA
CABINA OSPITI DX	MD299_R01_RA01	ARMADIO	LASTRA SCURA	1

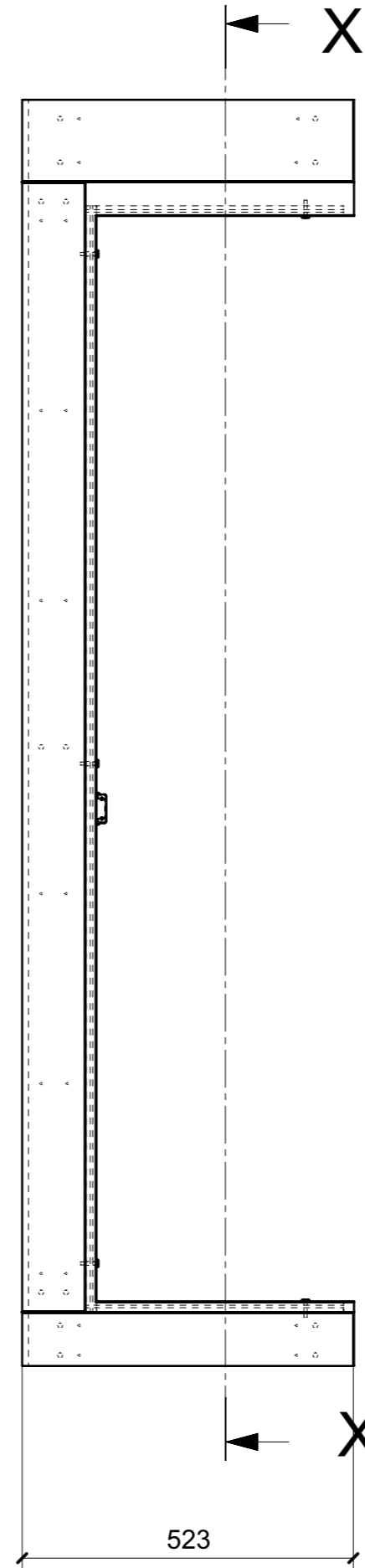
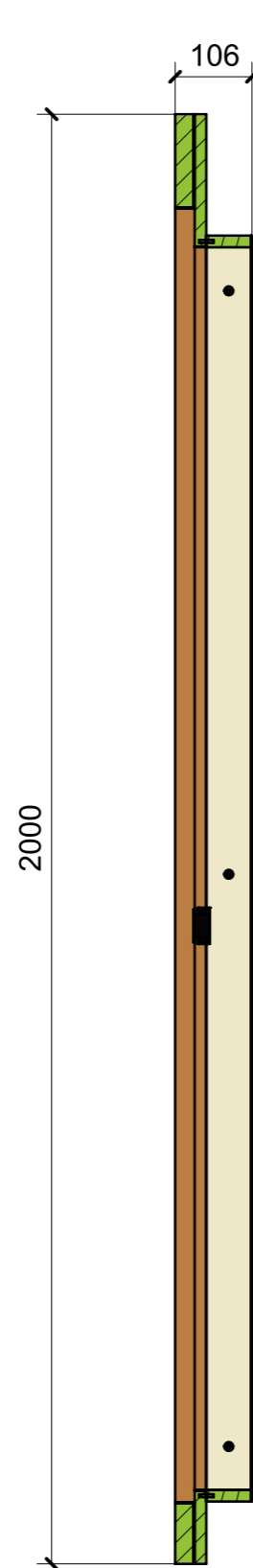
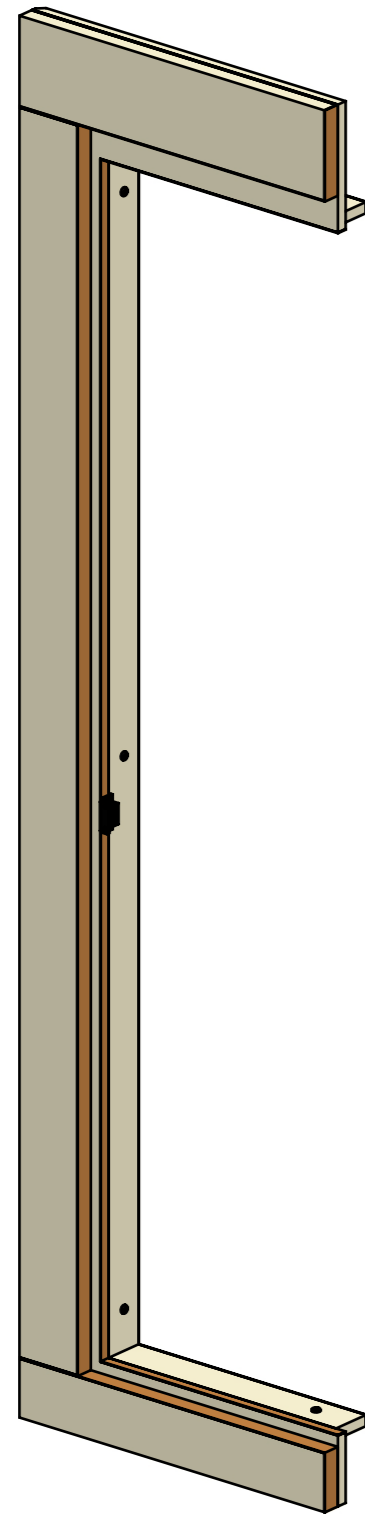
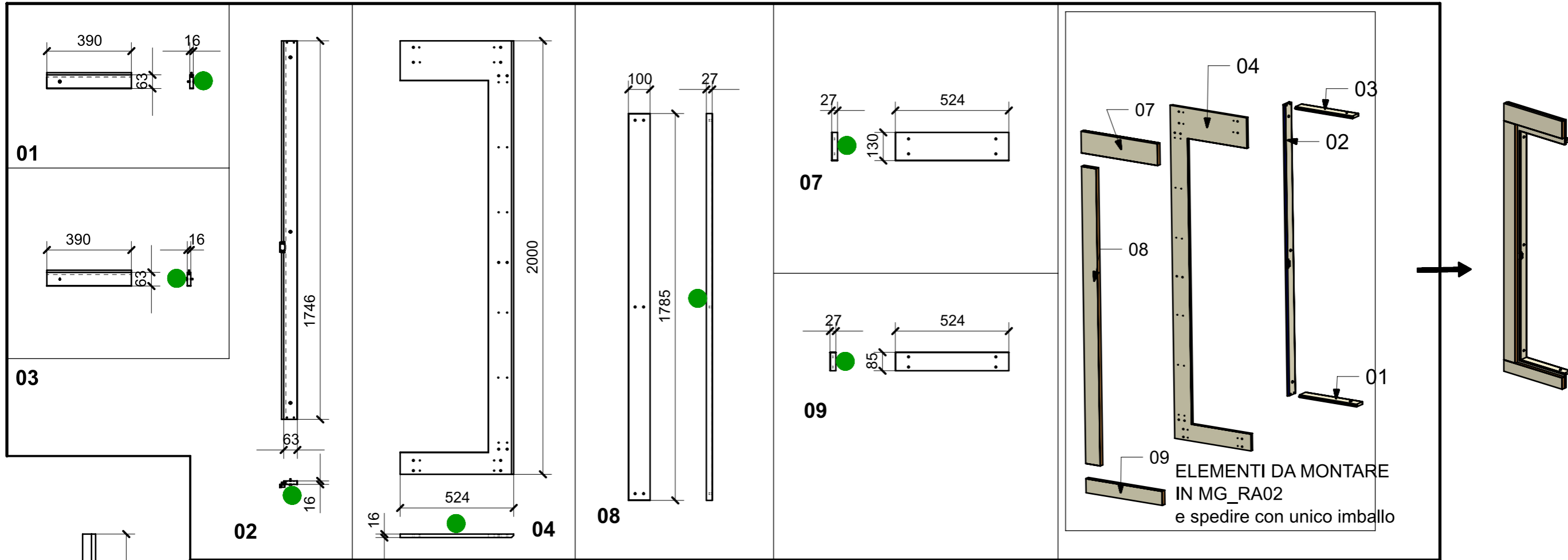

ELEMENTI DA MONTARE IN MG_RA02 e spedire con unico imballo

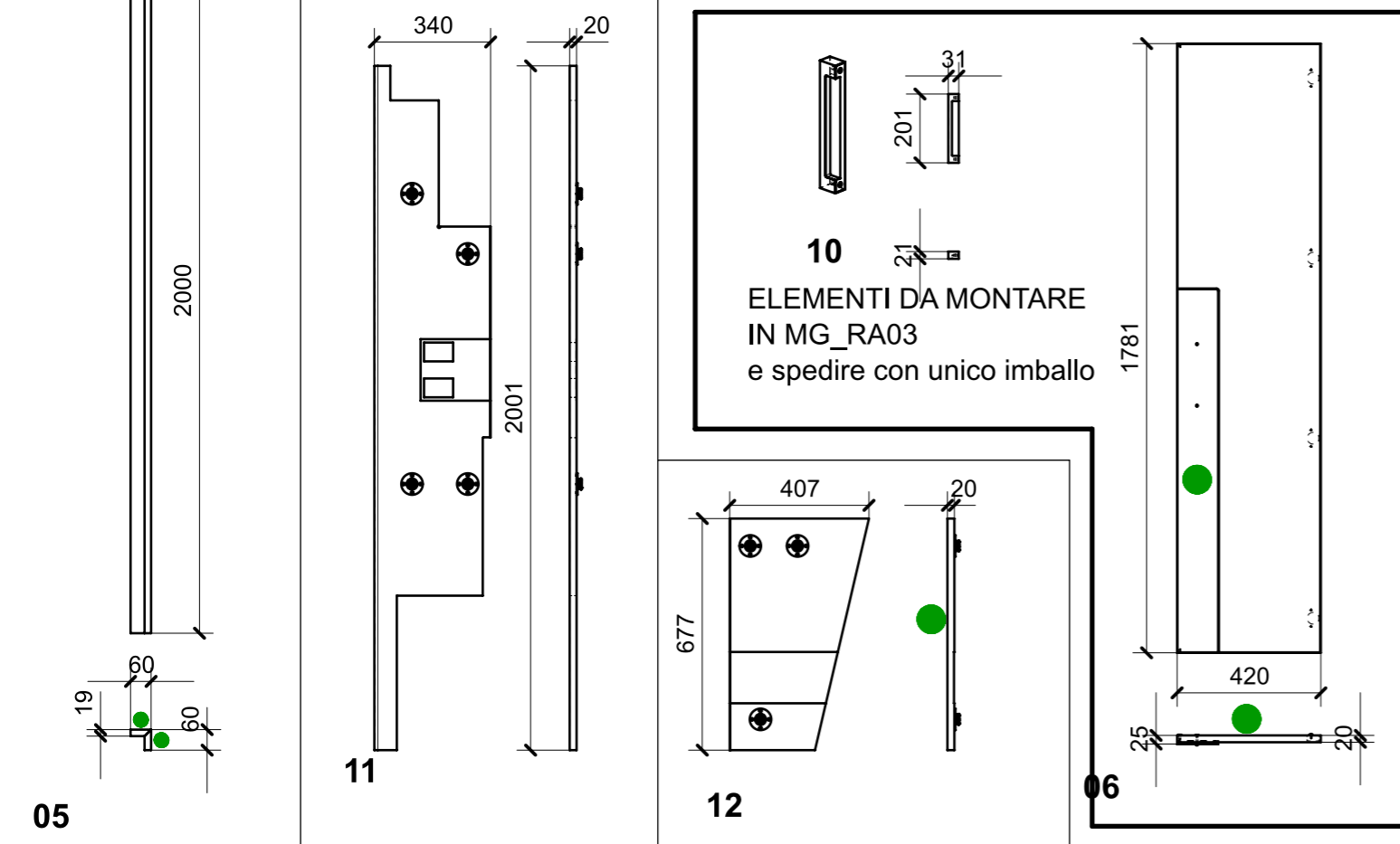

ELEMENTI DA MONTARE IN MG_RA03 e spedire con unico imballo

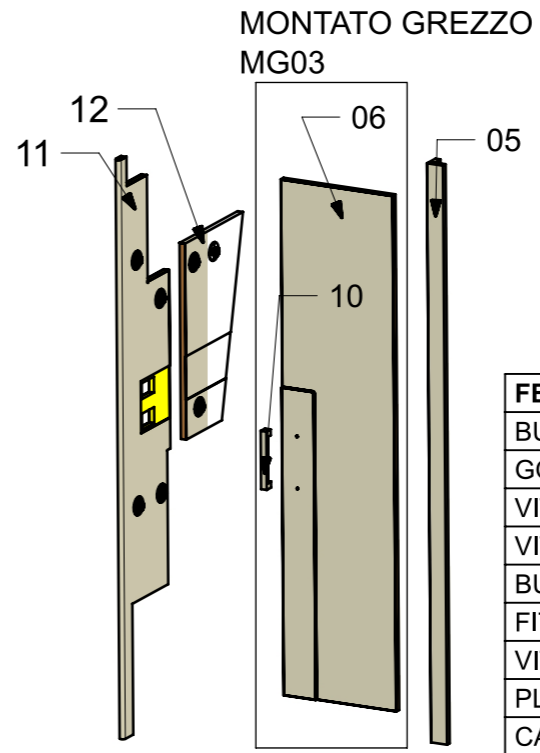

MONTATO GREZZO MG03

FERRAMENTA	QTY
BUSSOLA 4MA X 10 FORO DIAM.6	2
GOMMINO PARACOLPO ANTA	2
VITE 4MA X 30 TESTA SVASATA ESAGONALE NERA	2
VITE 4MAX8 ANKOR BORGHIS X CERNIERA PIANA	8
BUSSOLA 5MA ANKOR BORGHIS X CERNIERA PIANA	8
FITLOCK M_MASCHERPA_3MM_6020202101	7
VITE 5MA X 25 TESTA BOMBATA	5
PLACCHETTA COUNTER STEEL_TECHNOPARTNER_MC-JM49	1
CALAMITA SEALED MAGNETIC_TECNOPARTNER_MC-JM50-BL	1

VERNICIATURA LASTRA/LACCATI:
 ● = VERNICIARE 1 LATO + FILI RASATI O BORDATI NESSUN SIMBOLO = VERNICIARE 2 LATI + FILI RASATI O BORDATI

LOCALE	CODICE	DESCRIZIONE COMPONENTE	FINITURA	Q.TA
CABINA OSPITI DX	MD299_MG_RA03	ARMADIO	LASTRA SCURA	1

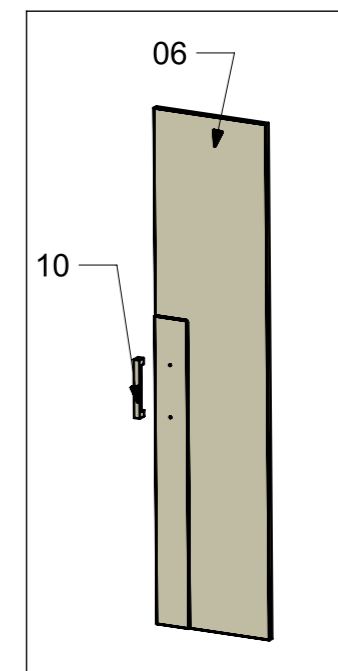
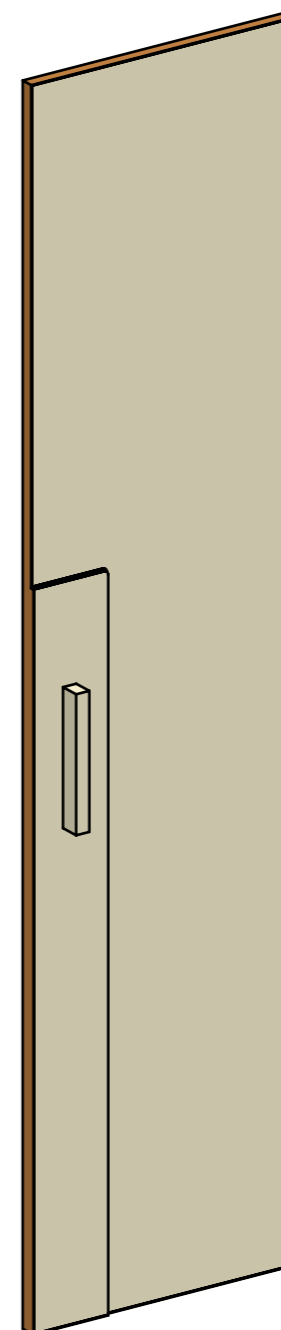
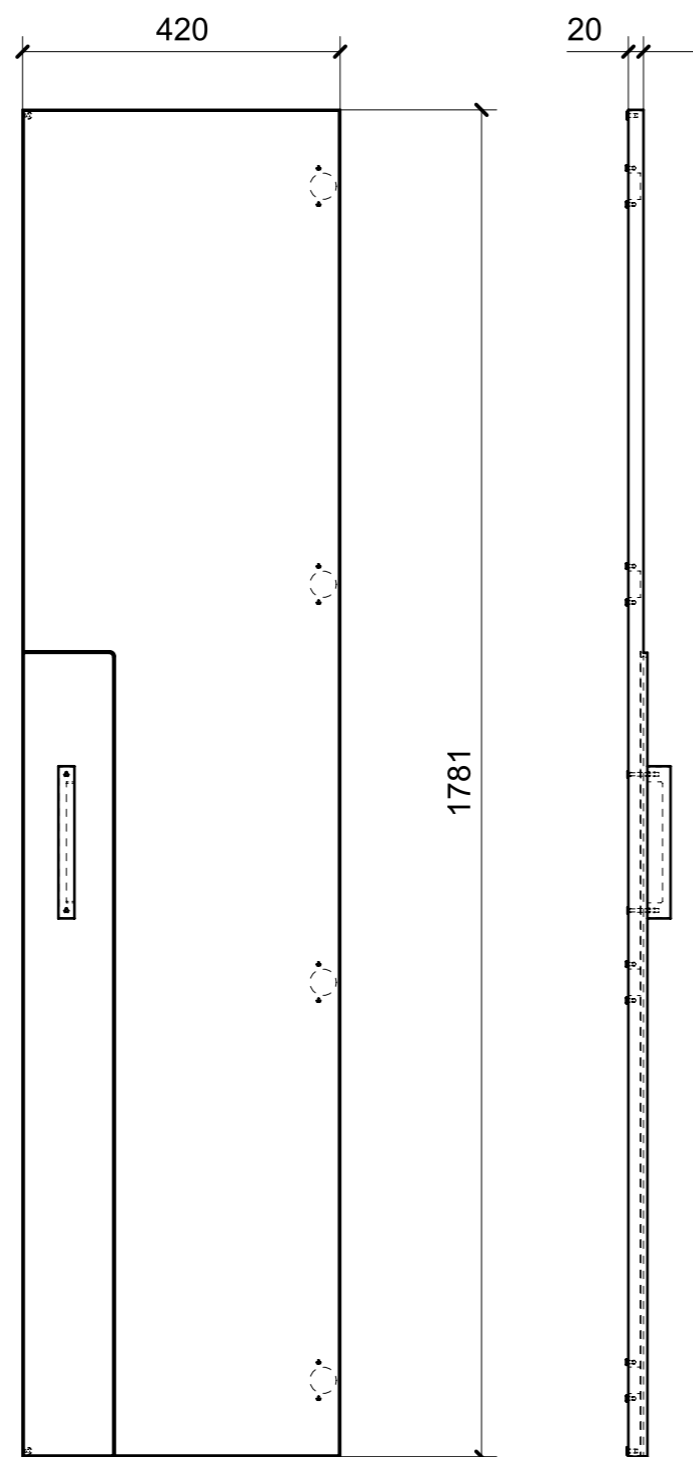

FERRAMENTA	QTY
BUSSOLA 4MA X 10 FORO DIAM.6	2
GOMMINO PARACOLPO ANTA	2
VITE 4MA X 30 TESTA SVASATA ESAGONALE NERA	2
VITE 4MAX8 ANKOR BORGHI X CERNIERA PIANA	8
BUSSOLA 5MA ANKOR BORGHI X CERNIERA PIANA	8

LOCALE	CODICE	DESCRIZIONE COMPONENTE	FINITURA	Q.TA
CABINA OSPITI DX	MD299_R01_RB01	BASE LETTO DX	LASTRA SCURA	1

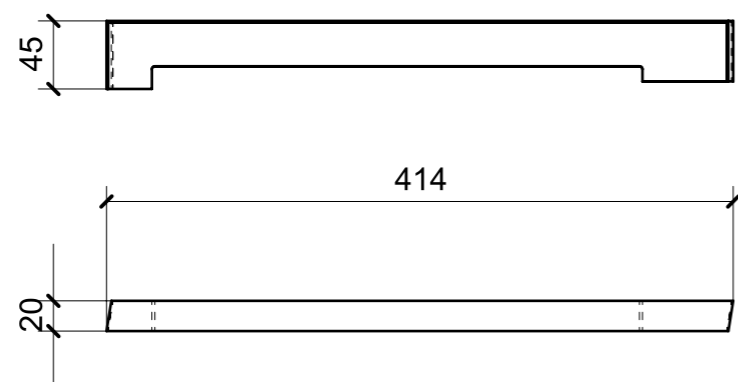

01

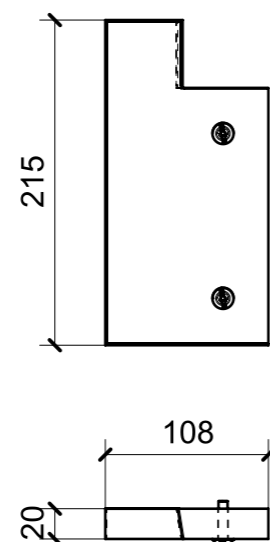
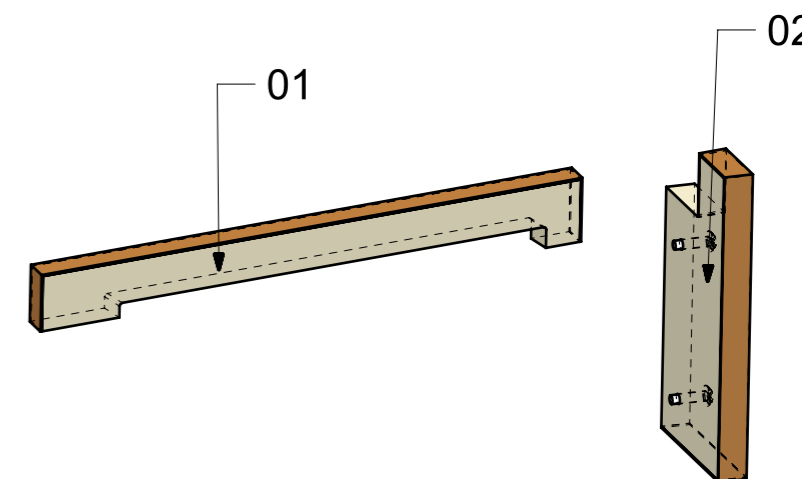

02

FERRAMENTA	QTY
VITE 6MA X 25 TESTA BOMBATA	2

VERNICIATURA LASTRA/LACCATI:

● = VERNICIARE 1 LATO + FILI RASATI O BORDATI

NESSUN SIMBOLO = VERNICIARE 2 LATI + FILI RASATI O BORDATI

LOCALE	CODICE	DESCRIZIONE COMPONENTE	FINITURA	Q.TA
CABINA OSPITI DX	MD299_R01_RC01	COMODINO	LAISTRA SCURA	1

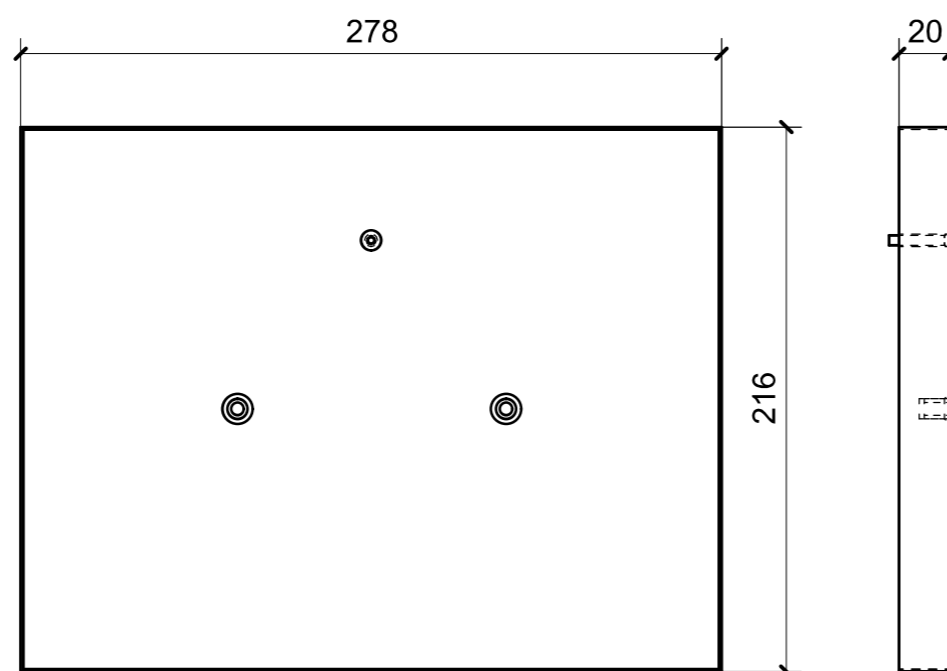

01

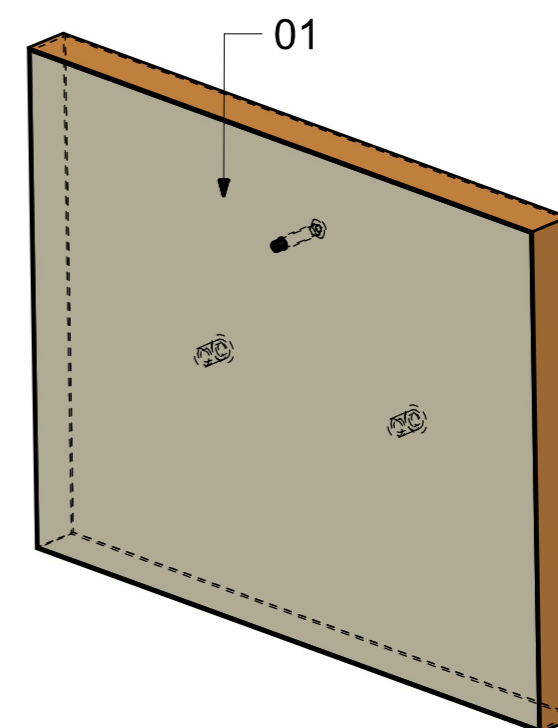

FERRAMENTA	QTY
VITE 4MA X 25 TESTA SVASATA ESAGONALE NERA	1
BUSSOLA 5MA X 10 FORO DIAM.8	2

VERNICIATURA LASTRA/LACCATI:

● = VERNICIARE 1 LATO + FILI RASATI O BORDATI

NESSUN SIMBOLO = VERNICIARE 2 LATI + FILI RASATI O BORDATI

LOCALE	CODICE	DESCRIZIONE COMPONENTE	FINITURA	Q.TA
CABINA OSPITI DX	MD299_R01_RD01	BASE LETTO SX	LASTRA SCURA	1

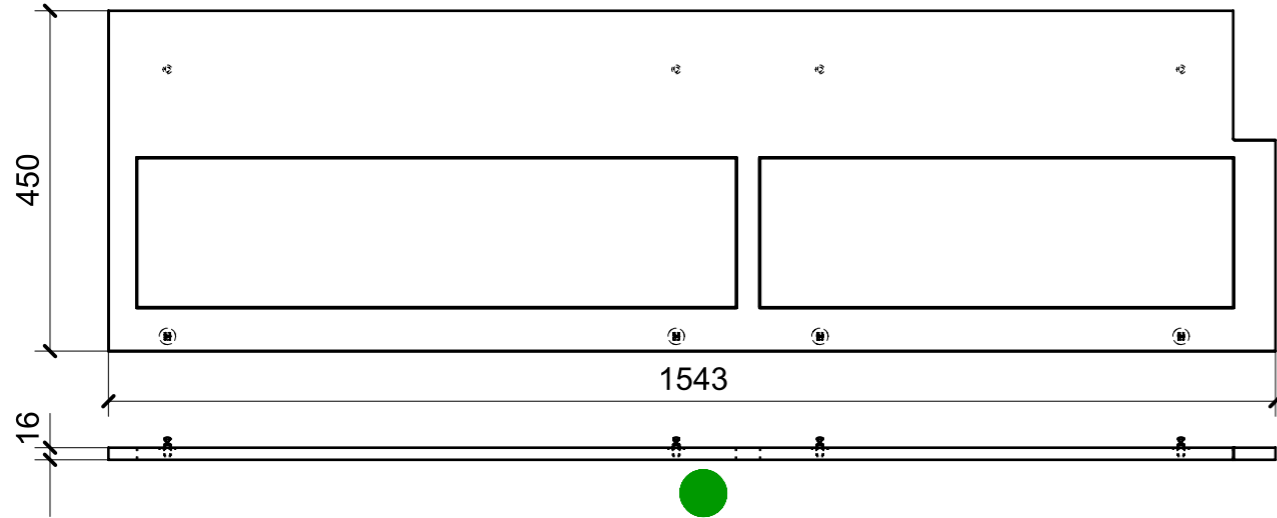

01

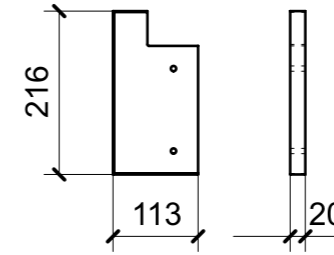

04

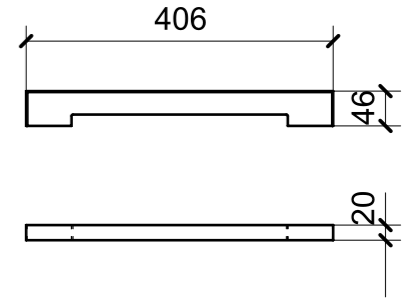

05

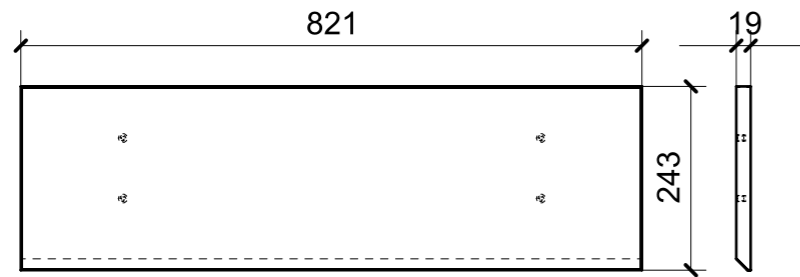

02

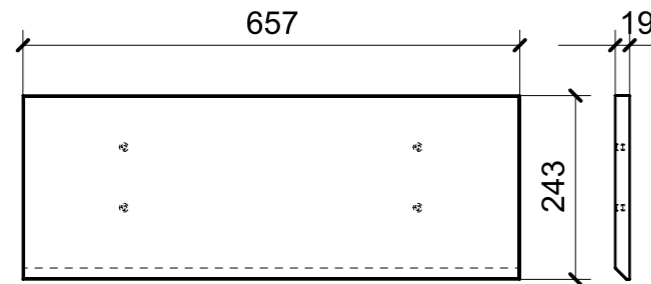
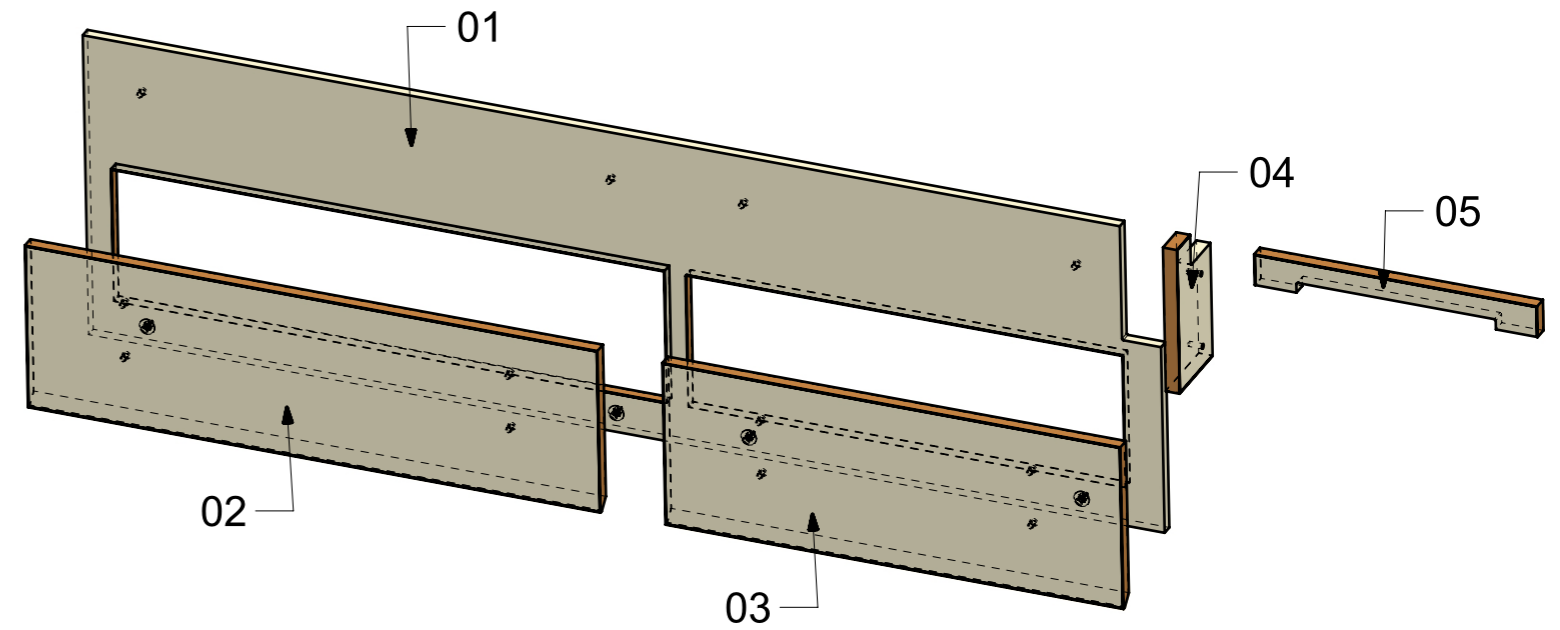

03

FERRAMENTA	QTY
BUSSOLA 5MA X 10 FORO DIAM.8	8
BUSSOLA 6MA X 10 FORO DIAM.8	4
MS INCASSO_ITALVIPLA_972_FMPC_M1B	4

VERNICIATURA LASTRA/LACCATI:

● = VERNICIARE 1 LATO + FILI RASATI O BORDATI

NESSUN SIMBOLO = VERNICIARE 2 LATI + FILI RASATI O BORDATI

LOCALE	CODICE	DESCRIZIONE COMPONENTE	FINITURA	Q.TA
CABINA OSPITI DX	MD299_MG_RE01	STRUTTURA TESTALETTO	LASTRA SCURA	1

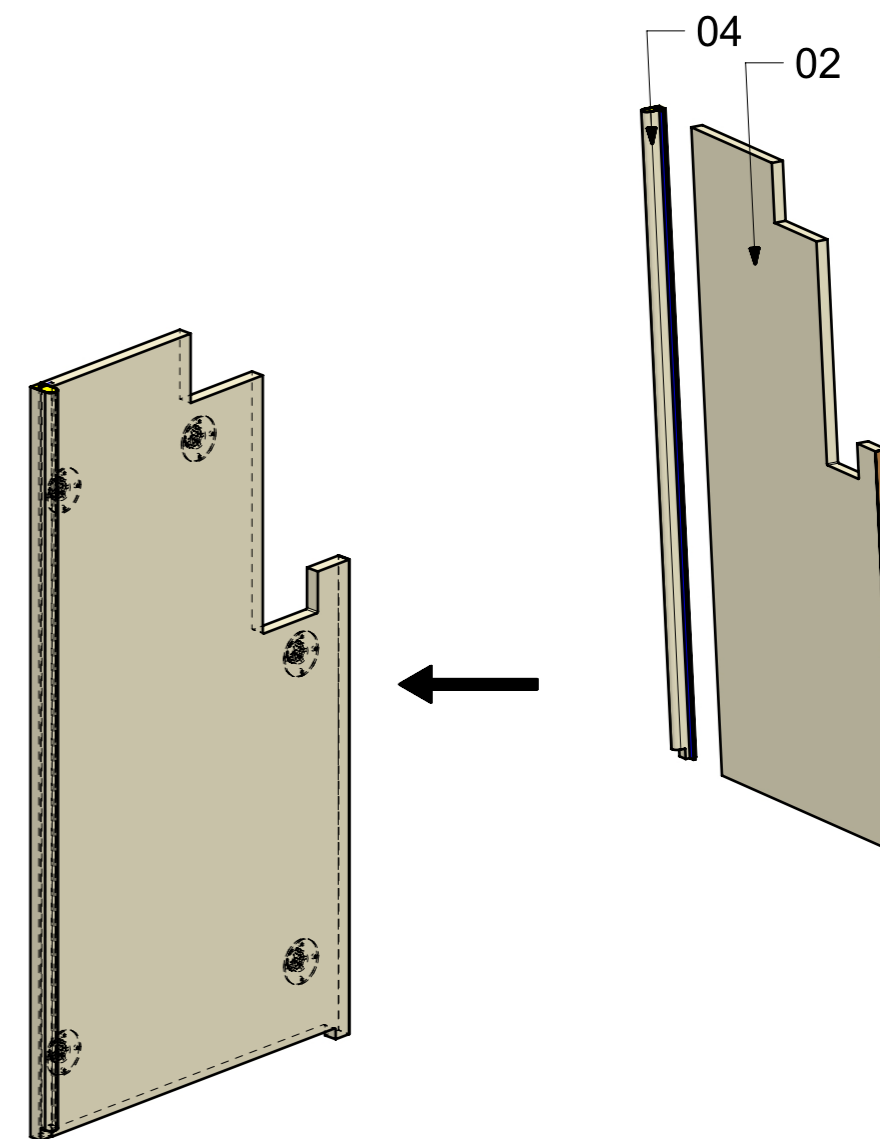
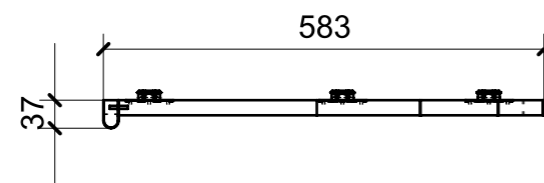
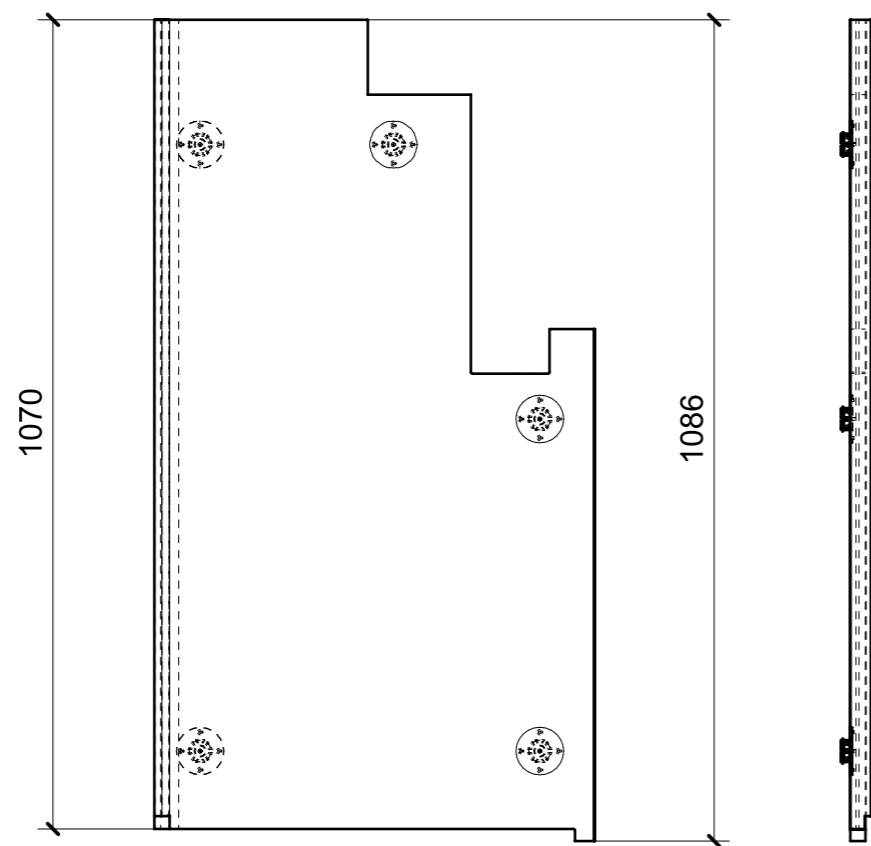

FERRAMENTA	QTY
FITLOCK M_MASCHERPA_3MM_6020202101	5

LOCALE	CODICE	DESCRIZIONE COMPONENTE	FINITURA	Q.TA
CABINA OSPITI DX	MD299_R01_RE01	STRUTTURA TESTALETTO	LASTRA SCURA	1

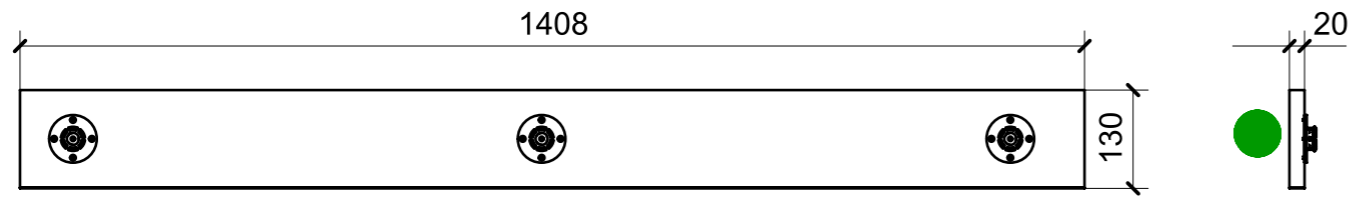

01

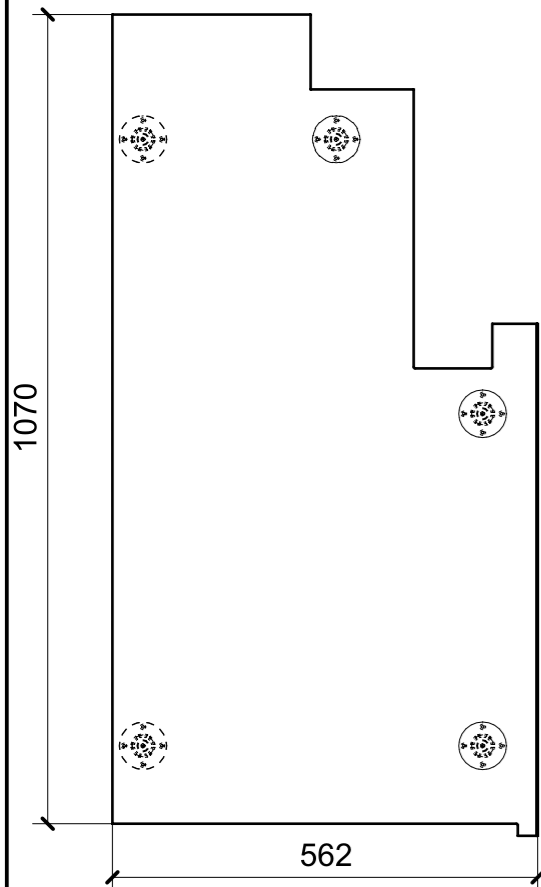
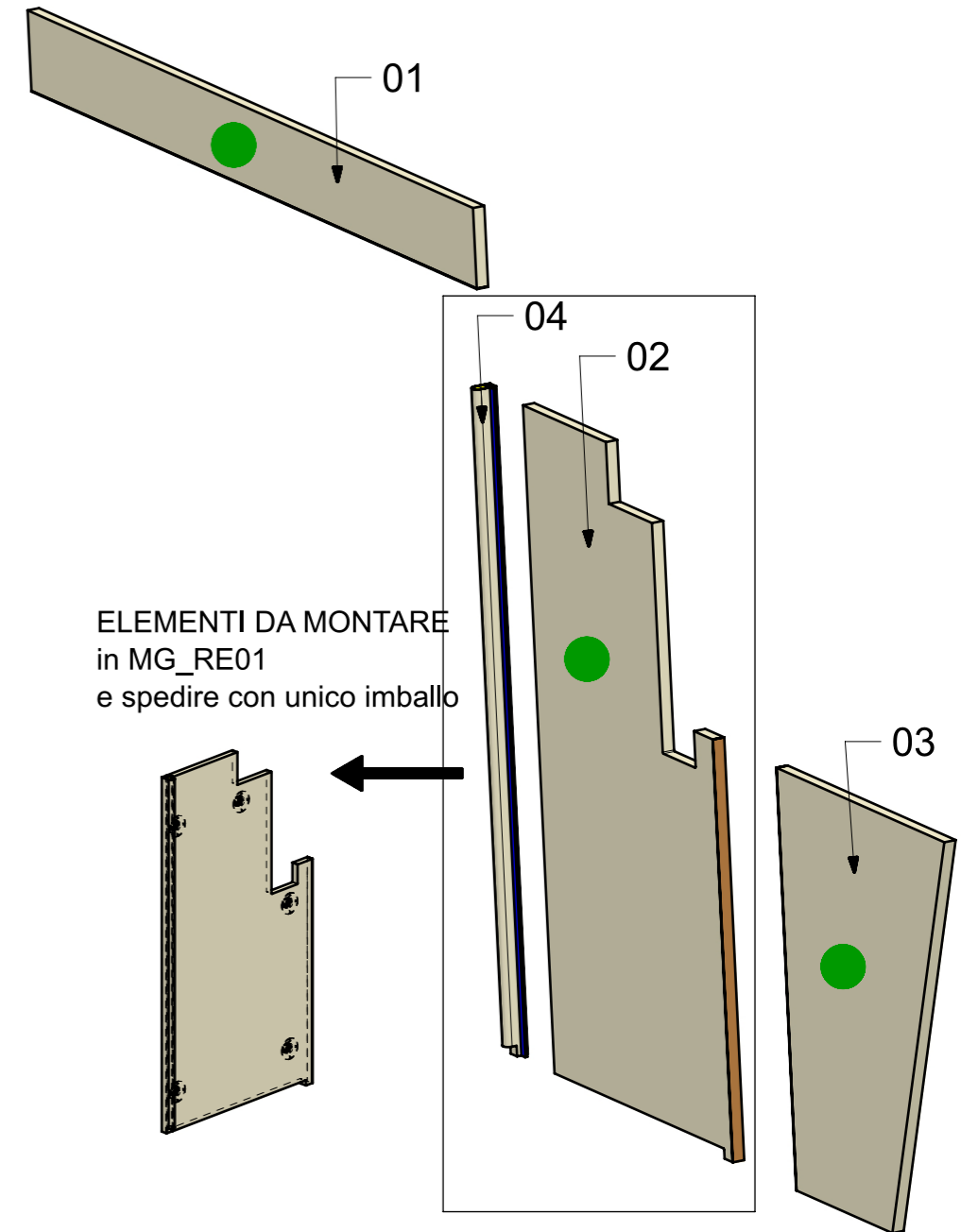

02

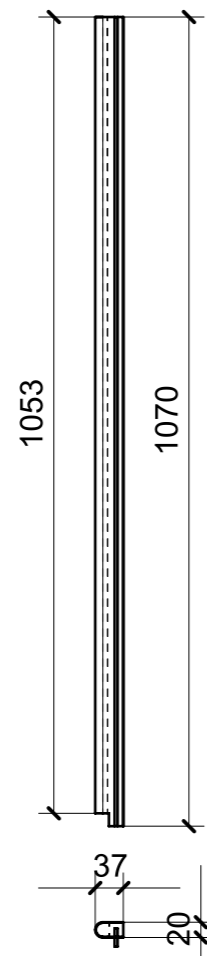

04

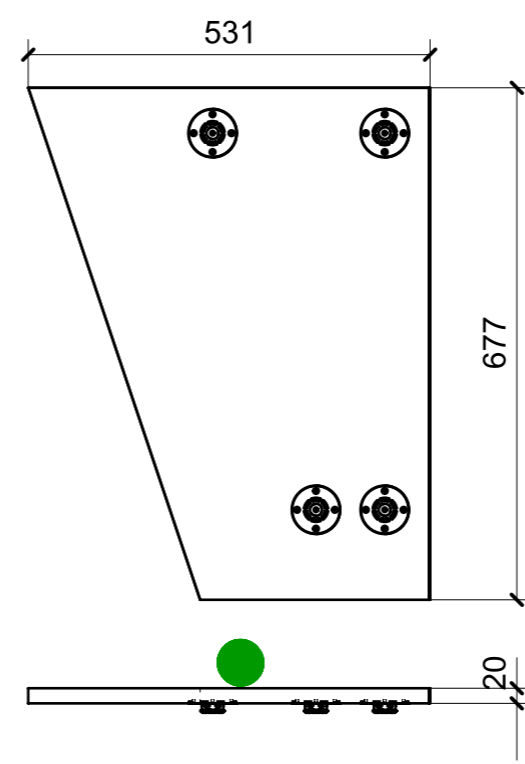

03

FERRAMENTA	QTY
MD299_GR03_R01_RE01_04	1
FITLOCK M_MASCHERPA_3MM_6020202101	12

VERNICIATURA LASTRA/LACCATI:
 ● = VERNICIARE 1 LATO + FILI RASATI O BORDATI NESSUN SIMBOLO = VERNICIARE 2 LATI + FILI RASATI O BORDATI

LOCALE	CODICE	DESCRIZIONE COMPONENTE	FINITURA	Q.TA
CABINA OSPITI DX	MD299_MG_RF01	PENSILE	LACCATO BIANCO 9010	1

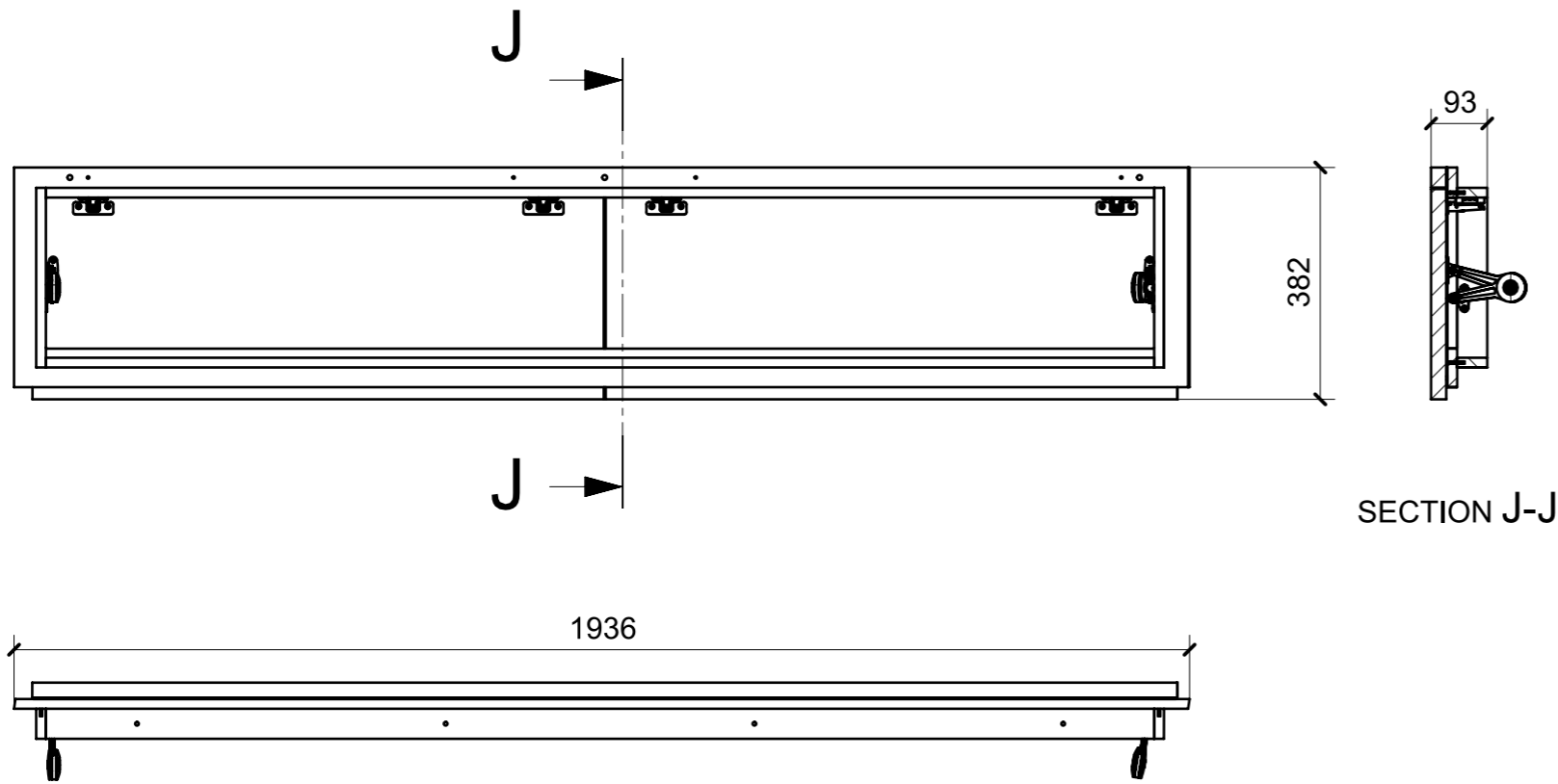

SECTION J-J

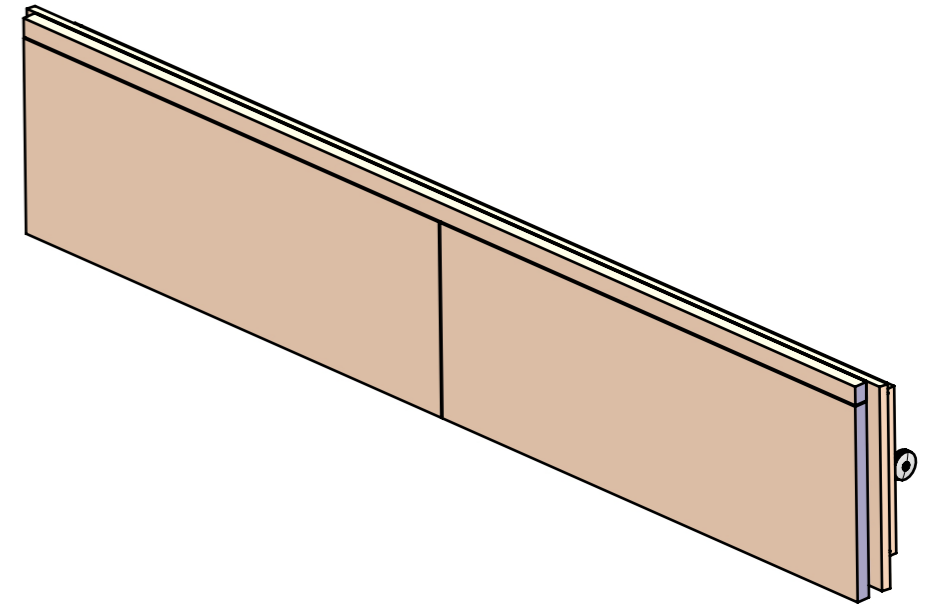
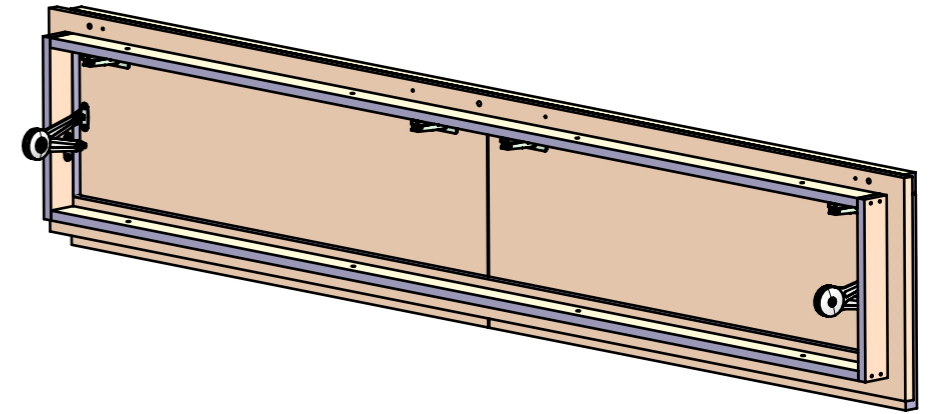

FERRAMENTA	QTY
BASE_6_HAFELE_329_84_026	4
BRACCETTO PER ANTA_HAFELE_373_66_611	1
BRACCETTO PER ANTA_HAFELE_373_66_611MIRROR_	1
BUSSOLA 5MA ANKOR BORGHI X CERNIERA PIANA	16
CERNIERA 94° PIANA AMMORTIZZATA_HAFELE_329_49_310	4
GOMMINO PARACOLPO ANTA	4
VITE 4MAX8 ANKOR BORGHI X CERNIERA PIANA	16

LOCALE	CODICE	DESCRIZIONE COMPONENTE	FINITURA	Q.TA
CABINA OSPITI DX	MD299_L01_RF01	PENSILE	LACCATO BIANCO 9010	1

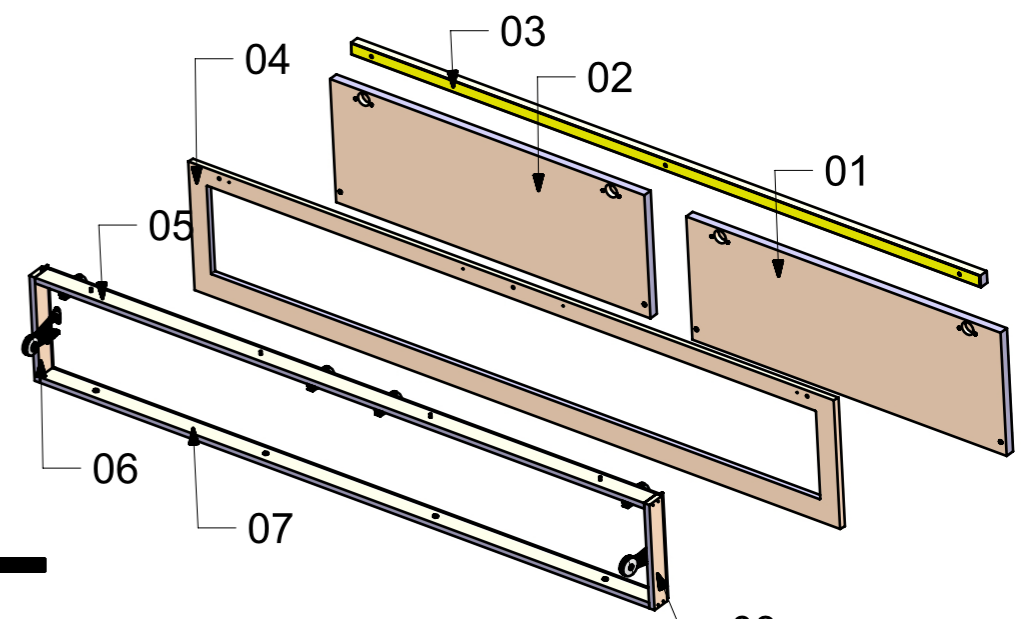
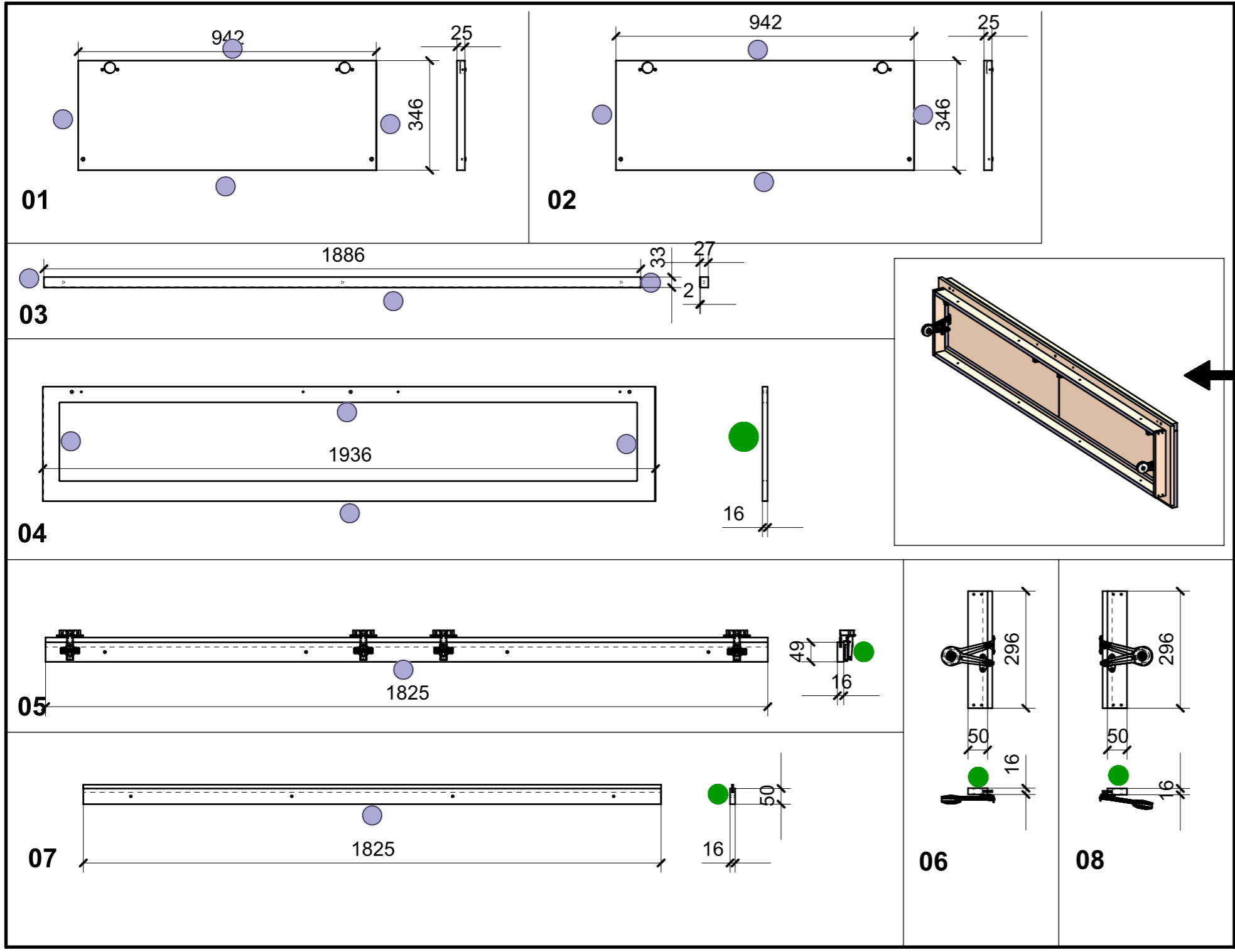

ELEMENTI DA MONTARE CON IN MG_RF01 e spedire con unico imballo

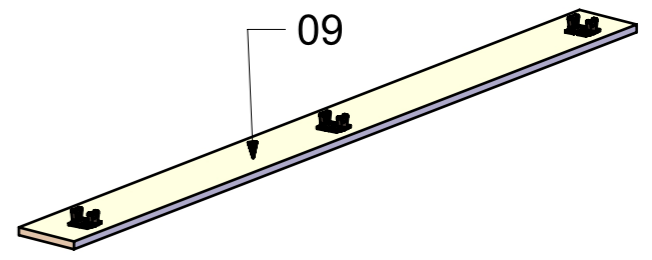

FERRAMENTA	QTY
BASE_6_HAFELE_329_84_026	4
BRACCETTO PER ANTA_HAFELE_373_66_611	1
BRACCETTO PER ANTA_HAFELE_373_66_611MIRROR_	1
BUSSOLA 5MA ANKOR BORGHI X CERNIERA PIANA	16
CERNIERA 94° PIANA AMMORTIZZATA_HAFELE_329_49_310	4
GOMMINO PARACOLPO ANTA	4
PARTE PANNELLO AS_HAFELE_262_50_359	6
VITE 4MAX8 ANKOR BORGHI X CERNIERA PIANA	16

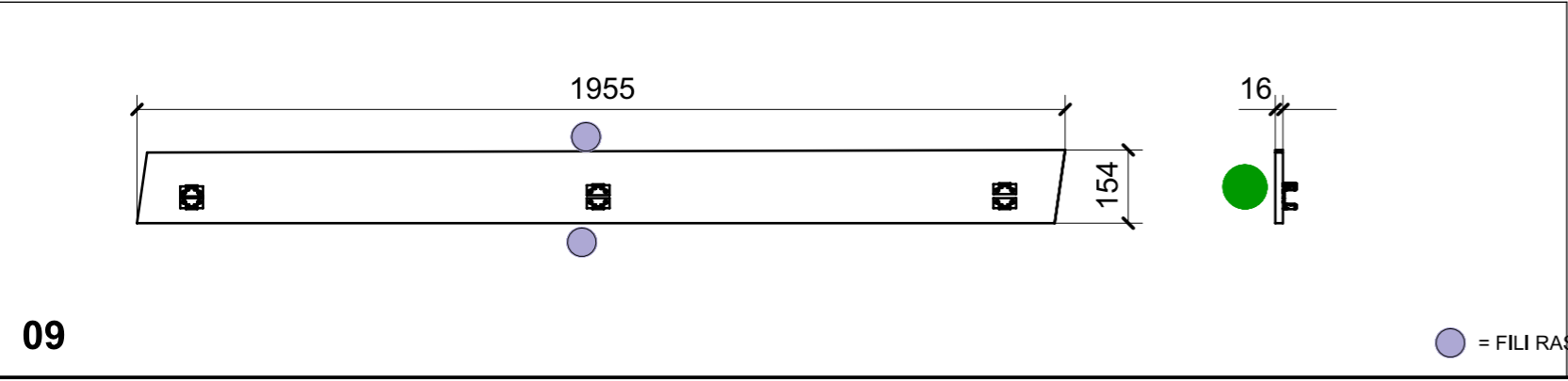

VERNICIATURA LASTRA/LACCATI:
 ● = FILI RASATI ● = VERNICIARE 1 LATO + FILI RASATI O BORDATI NESSUN SIMBOLO = VERNICIARE 2 LATI + FILI RASATI O BORDATI

LOCALE	CODICE	DESCRIZIONE COMPONENTE	FINITURA	Q.TA
CABINA OSPITI DX	MD299_R01_RG01	COLLEGAMENTO BASSO MURATA	LASTRA SCURA	1

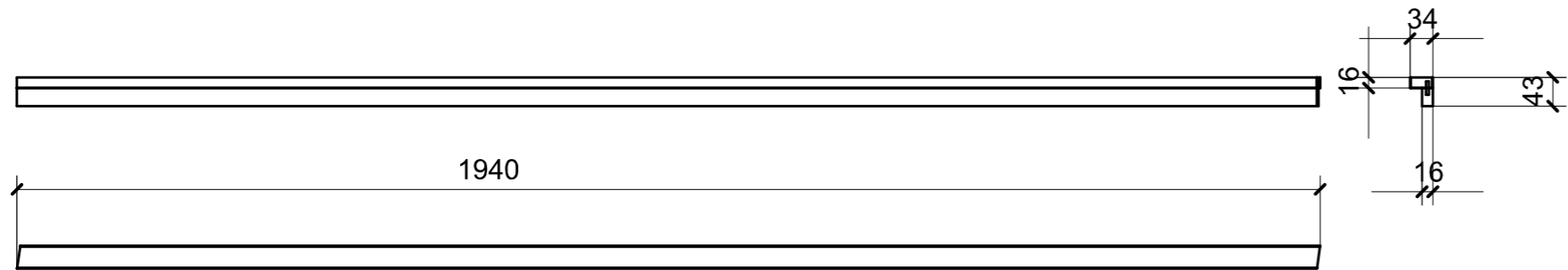

01

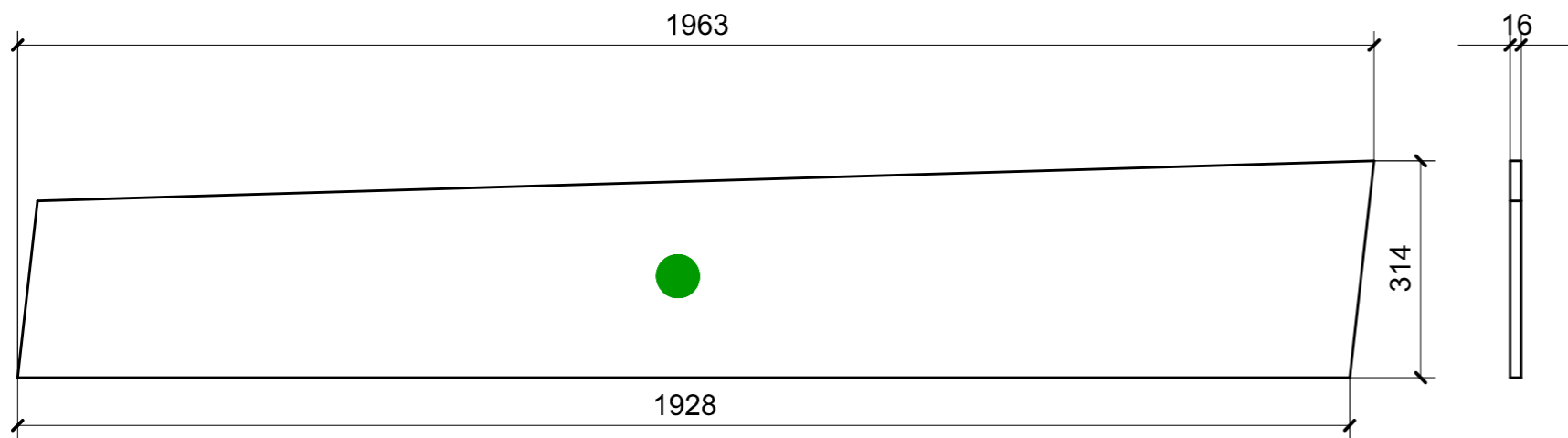

02

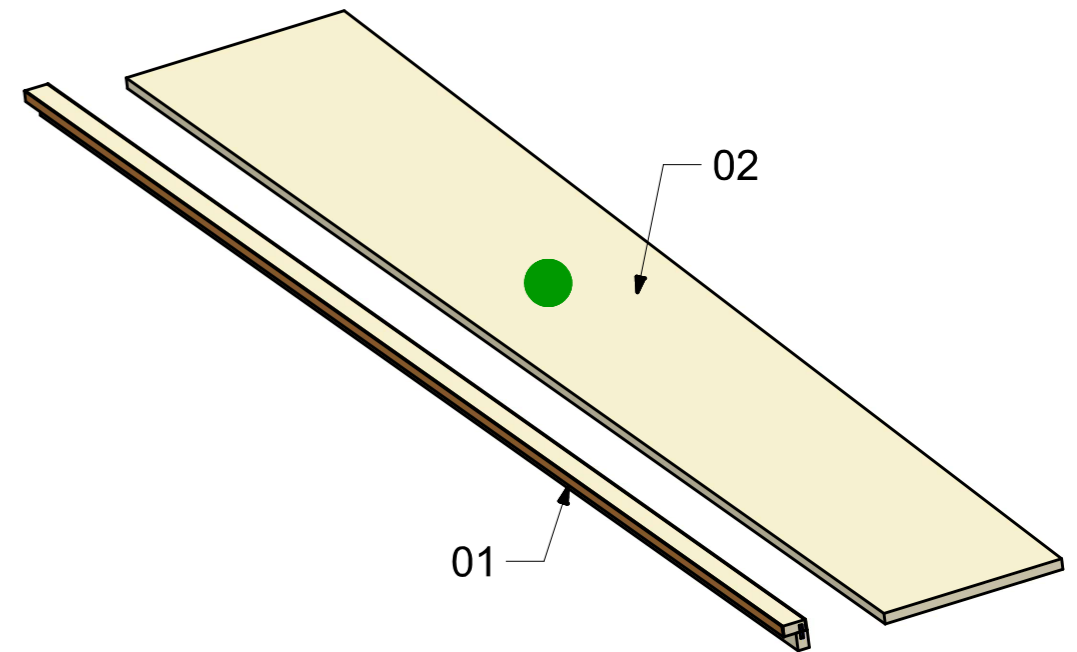

VERNICIATURA LASTRA/LACCATI:

● = VERNICIARE 1 LATO + FILI RASATI O BORDATI

NESSUN SIMBOLO = VERNICIARE 2 LATI + FILI RASATI O BORDATI

LOCALE	CODICE	DESCRIZIONE COMPONENTE	FINITURA	Q.TA
CABINA OSPITI DX	MD299_MF_RH01	CIELINO		1

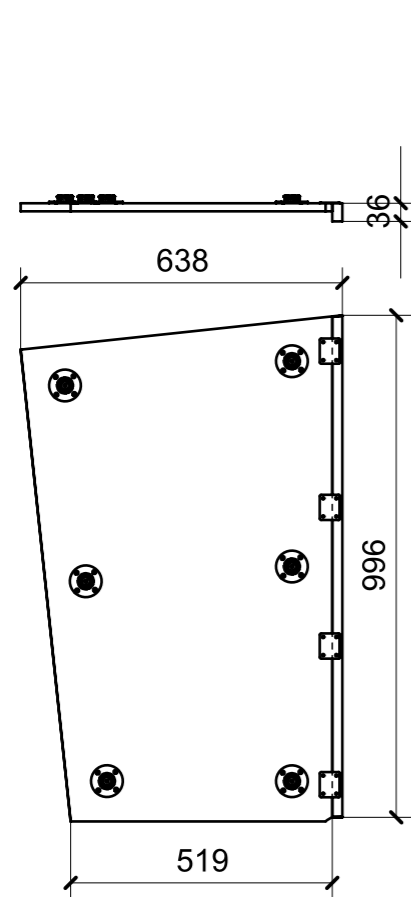

MF_RH01

FERRAMENTA	QTY
PIASTRINA SP.1MM 50X40_FBC_ART_264 Z	4
FITLOCK M_MASCHERPA_3MM_6020202101	6

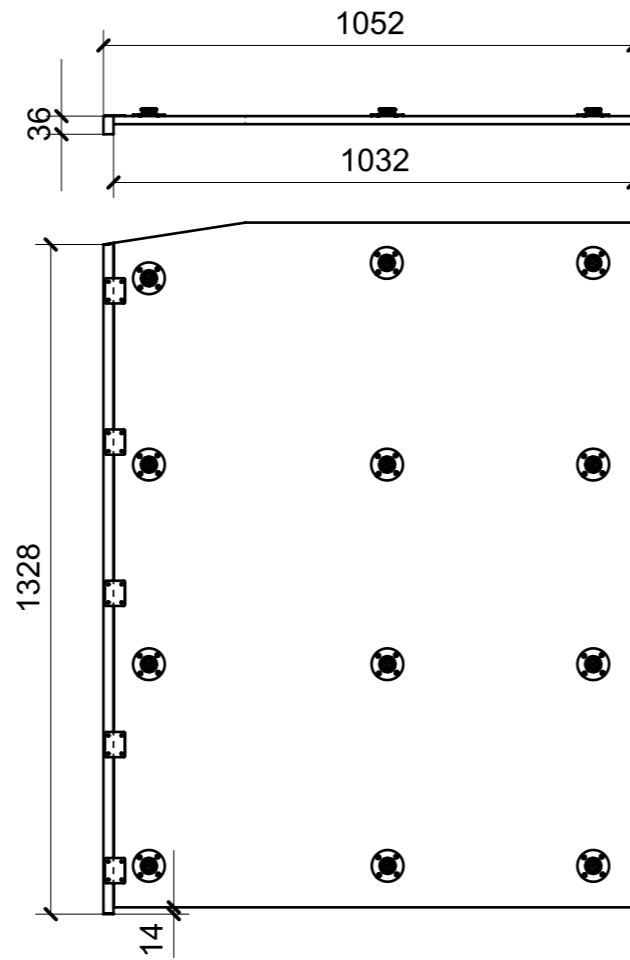

MF_RH03

FERRAMENTA	QTY
PIASTRINA SP.1MM 50X40_FBC_ART_264 Z	5
FITLOCK M_MASCHERPA_3MM_6020202101	12

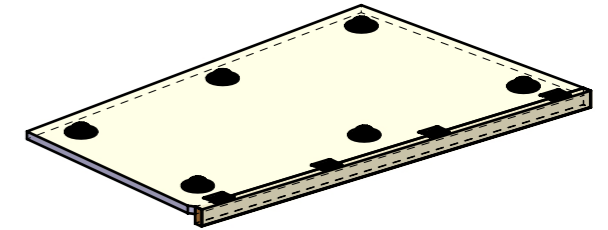

MF_RH01

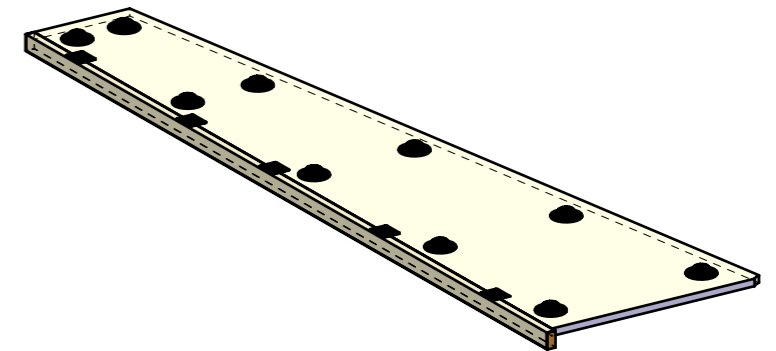

MF_RH02

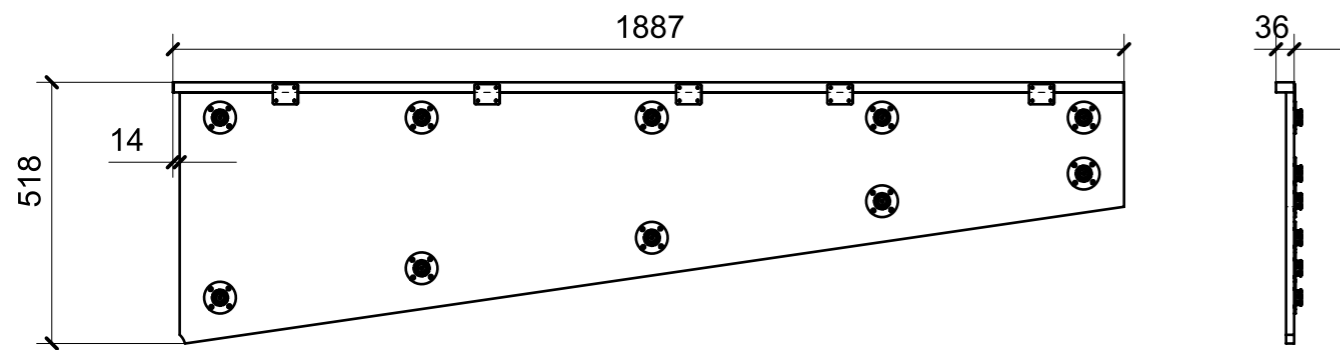

MF_RH02

FERRAMENTA	QTY
PIASTRINA SP.1MM 50X40_FBC_ART_264 Z	5
FITLOCK M_MASCHERPA_3MM_6020202101	10

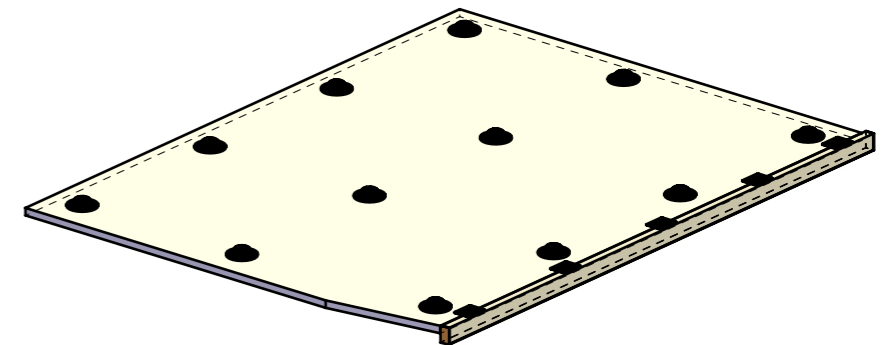

MF_RH03

LOCALE	CODICE	DESCRIZIONE COMPONENTE	FINITURA	Q.TA
CABINA OSPITI DX	MD299_R01_RH01	CIELINO	LASTRA SCURA	1

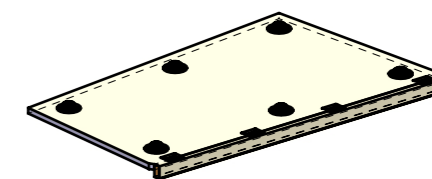
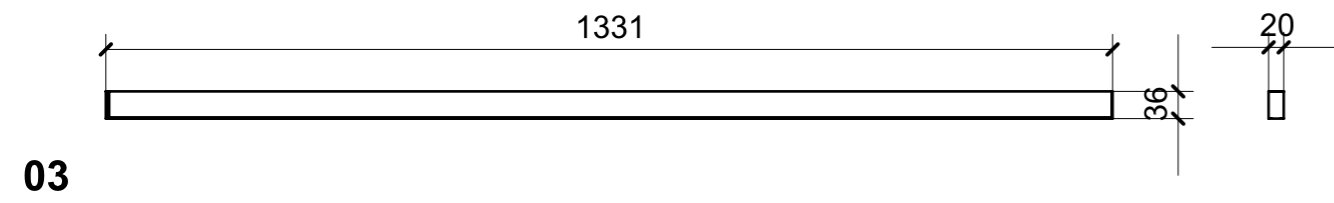
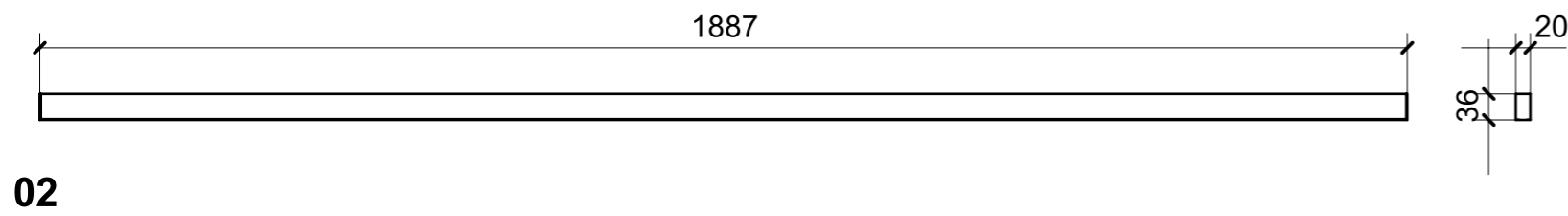
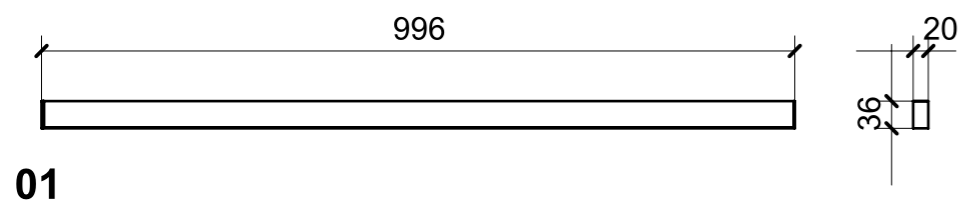

MF_RH01

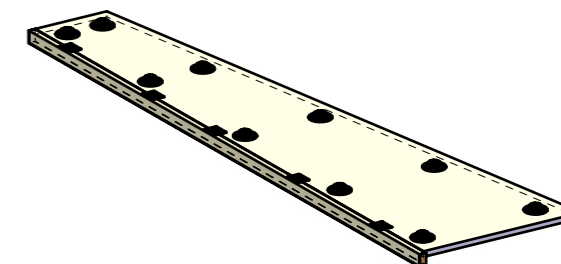

MF_RH02

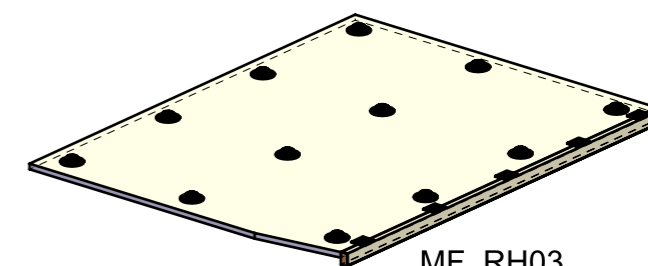

MF_RH03

01 02 03
 ELEMENTI DA MONTARE
 con L01_01/03/04 in MF_RH01; MF_RH02; MF_RH03
 e spedire con unico imballo

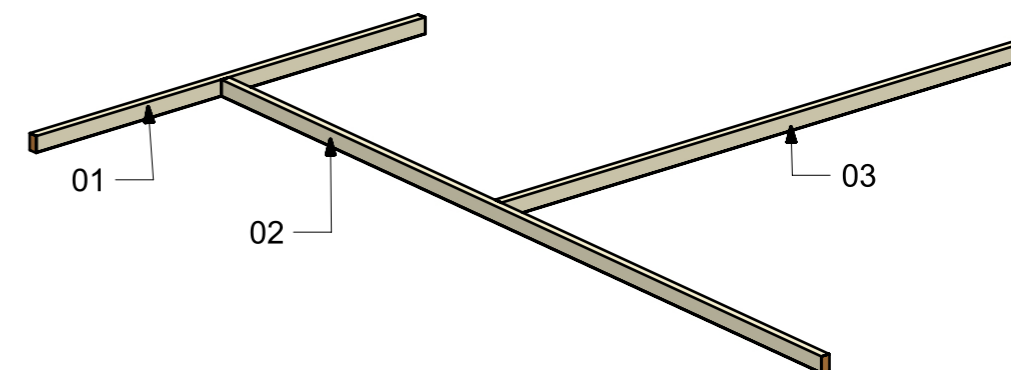

VERNICIATURA LASTRA/LACCATI:

● = VERNICIARE 1 LATO + FILI RASATI O BORDATI

NESSUN SIMBOLO = VERNICIARE 2 LATI + FILI RASATI O BORDATI

LOCALE	CODICE	DESCRIZIONE COMPONENTE	FINITURA	Q.TA
CABINA OSPITI DX	MD299_L01_RH01	CIELINO	LACCATO BIANCO 9010	1

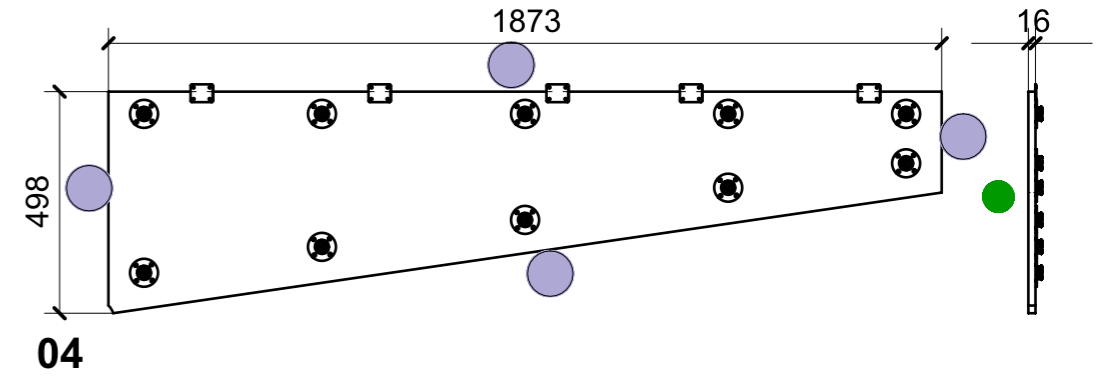
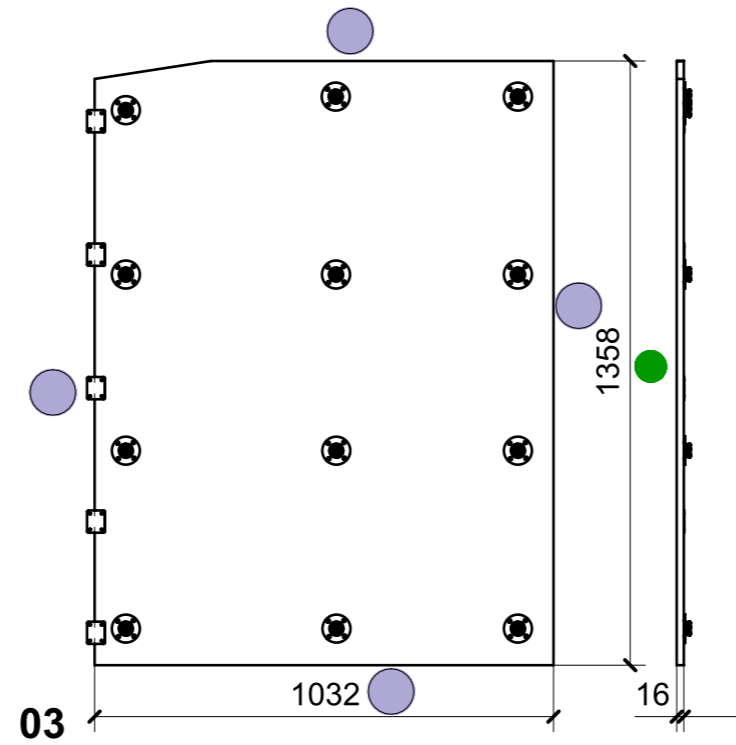
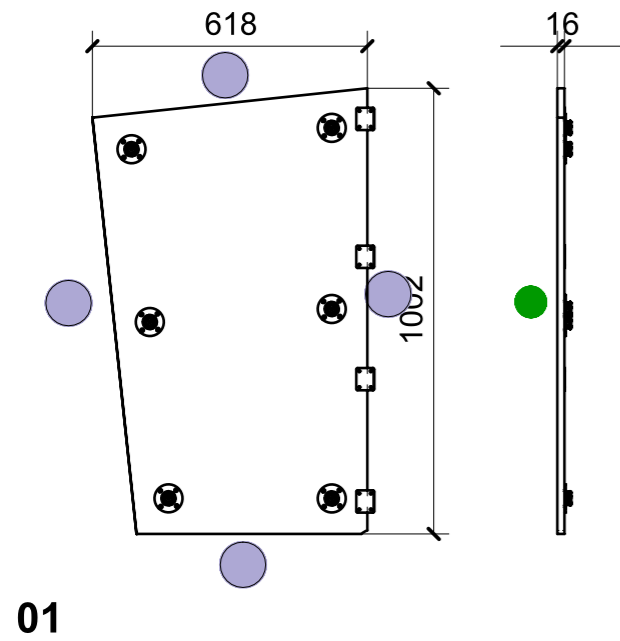

01 03 04
ELEMENTI DA MONTARE
con R01_01/02/03 in MF_RH01; MF_RH02; MF_RH03
e spedire con unico imballo

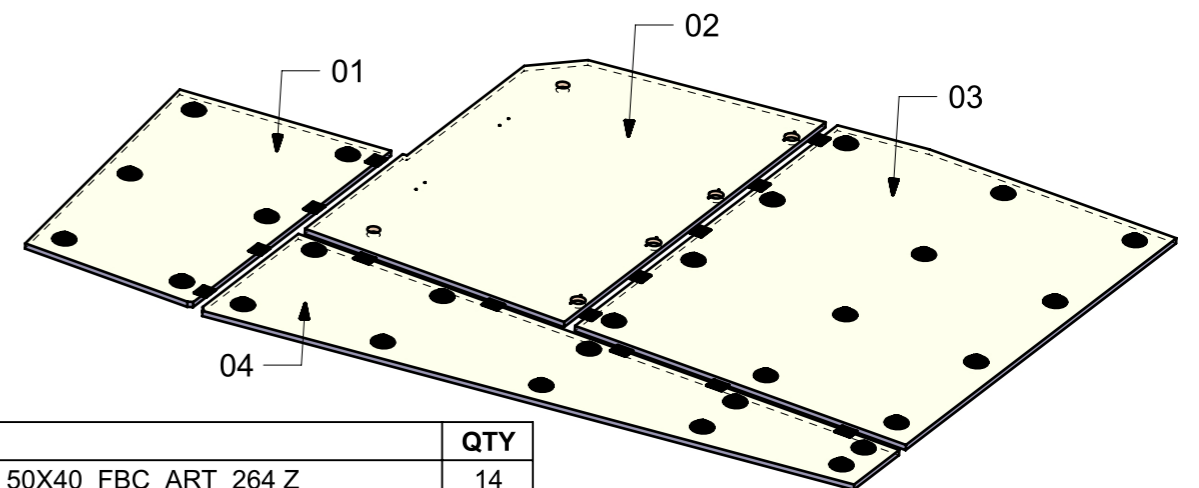
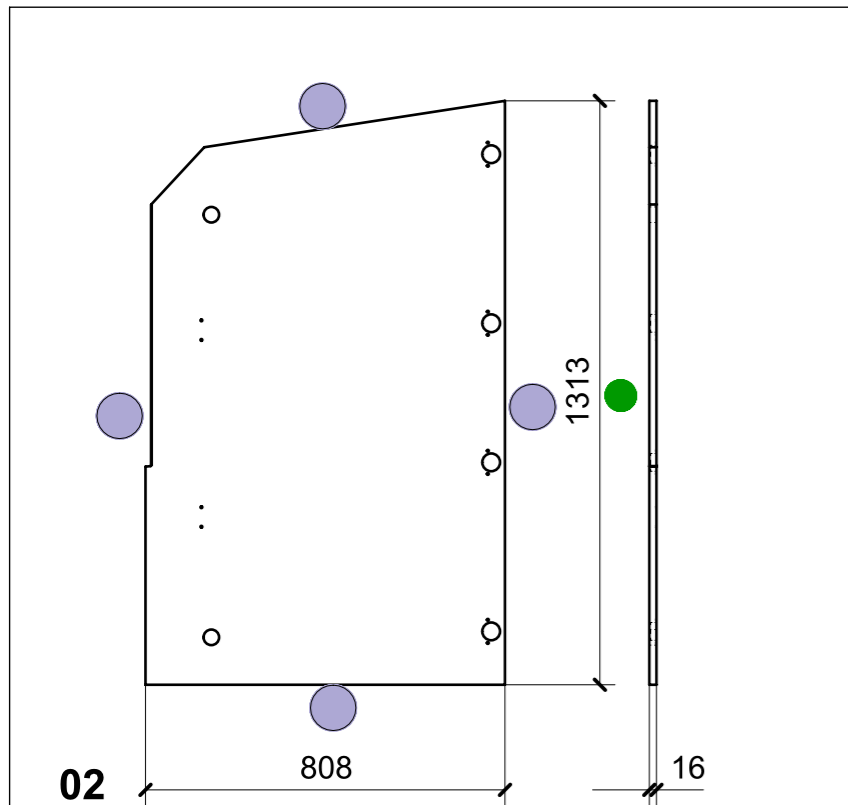
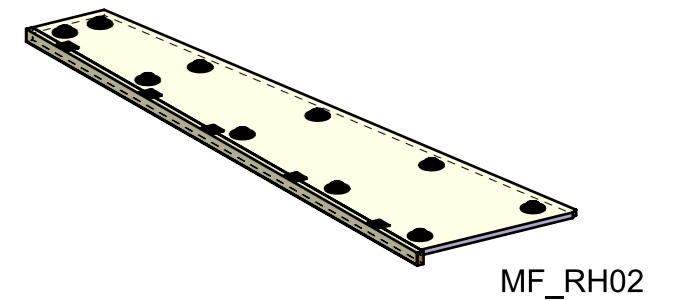
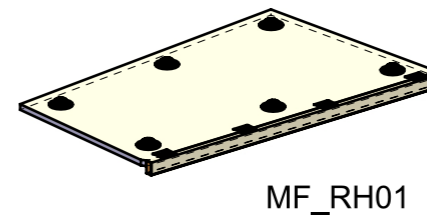
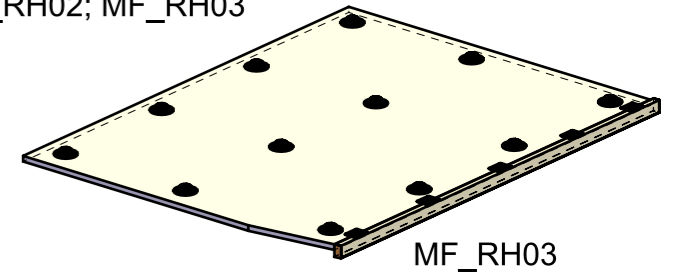

FERRAMENTA	QTY
PIASTRINA SP.1MM 50X40_FBC_ART_264 Z	14
FITLOCK M_MASCHERPA_3MM_6020202101	28

VERNICIATURA LASTRA/LACCATI:
 ● = FILI RASATI ● = VERNICIARE 1 LATO + FILI RASATI O BORDATI NESSUN SIMBOLO = VERNICIARE 2 LATI + FILI RASATI O BORDATI

LOCALE	CODICE	DESCRIZIONE COMPONENTE	FINITURA	Q.TA
CABINA OSPITI DX	MD299_R01_RI01	PLENUM	LASTRA SCURA	1

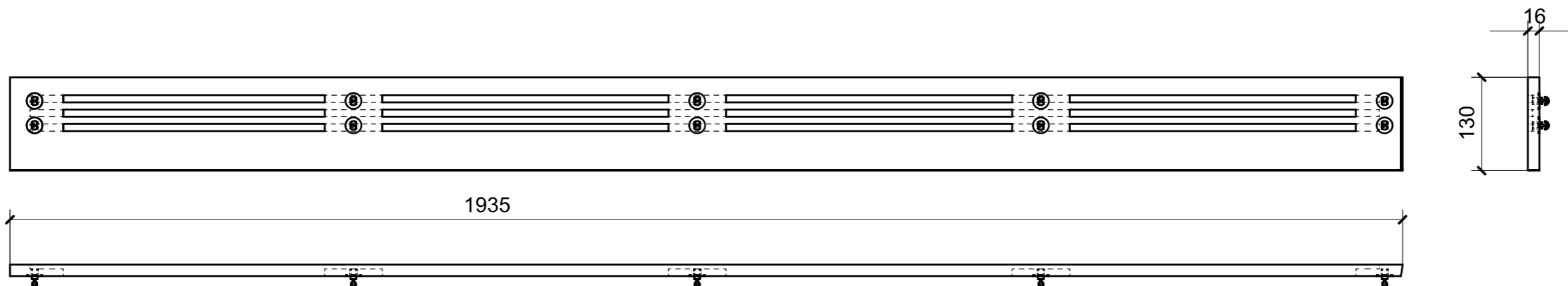

01

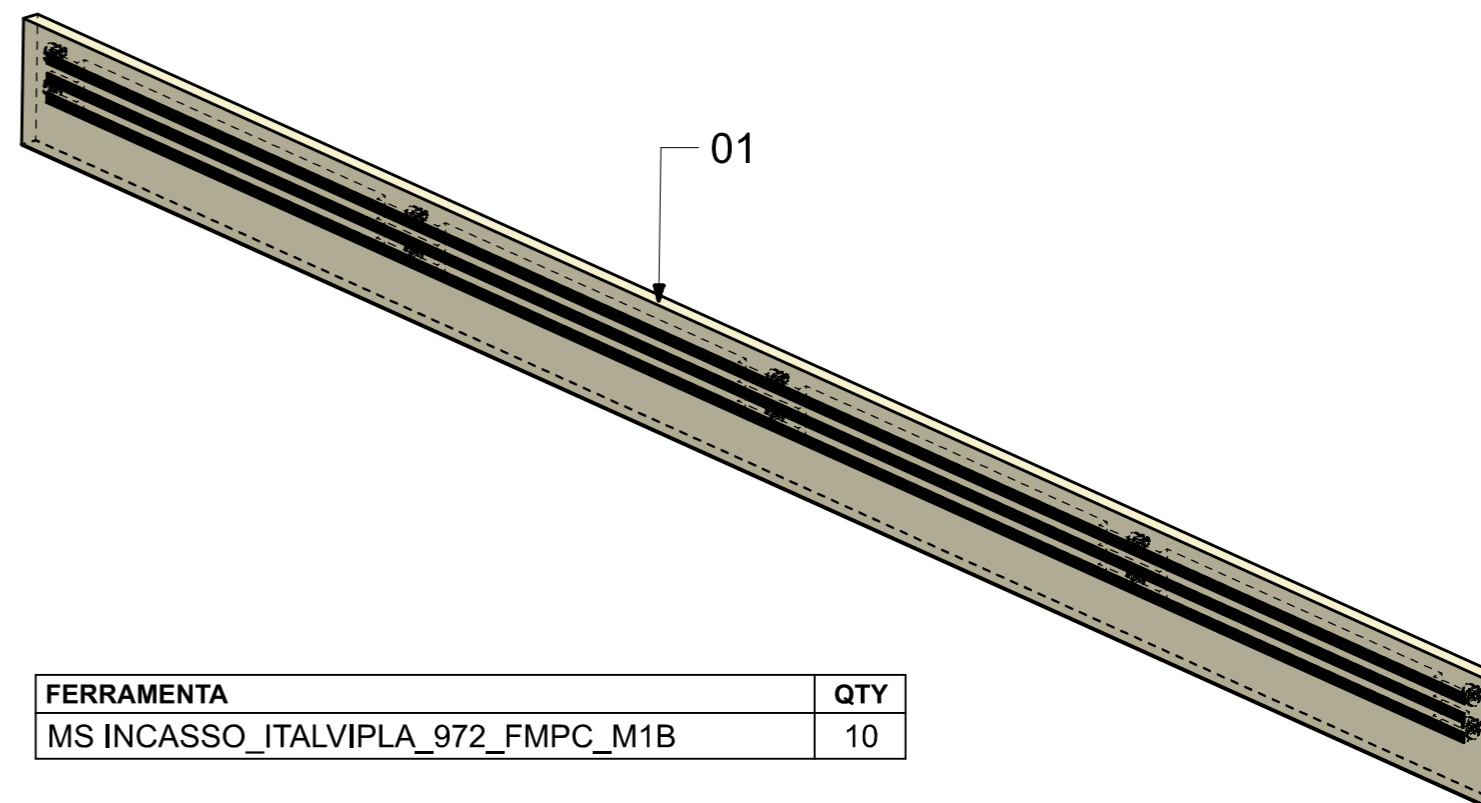

FERRAMENTA	QTY
MS INCASSO_ITALVIPLA_972_FMPC_M1B	10

VERNICIATURA LASTRA/LACCATI:

● = VERNICIARE 1 LATO + FILI RASATI O BORDATI

NESSUN SIMBOLO = VERNICIARE 2 LATI + FILI RASATI O BORDATI

LOCALE	CODICE	DESCRIZIONE COMPONENTE	FINITURA	Q.TA
CABINA OSPITI DX	MD299_L01_RI01	PLENUM	LACCATO BIANCO 9010 OPACO	1

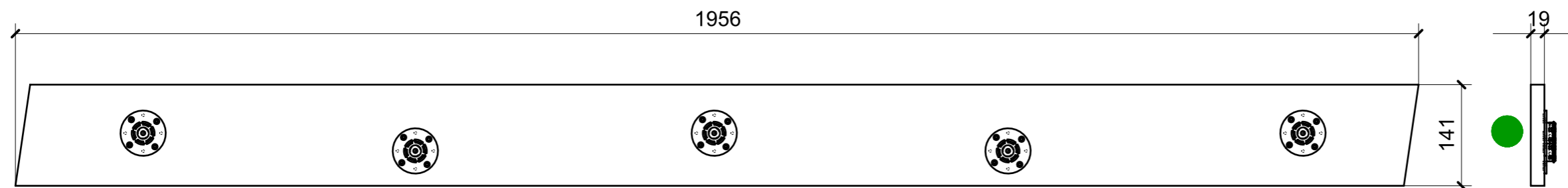

01

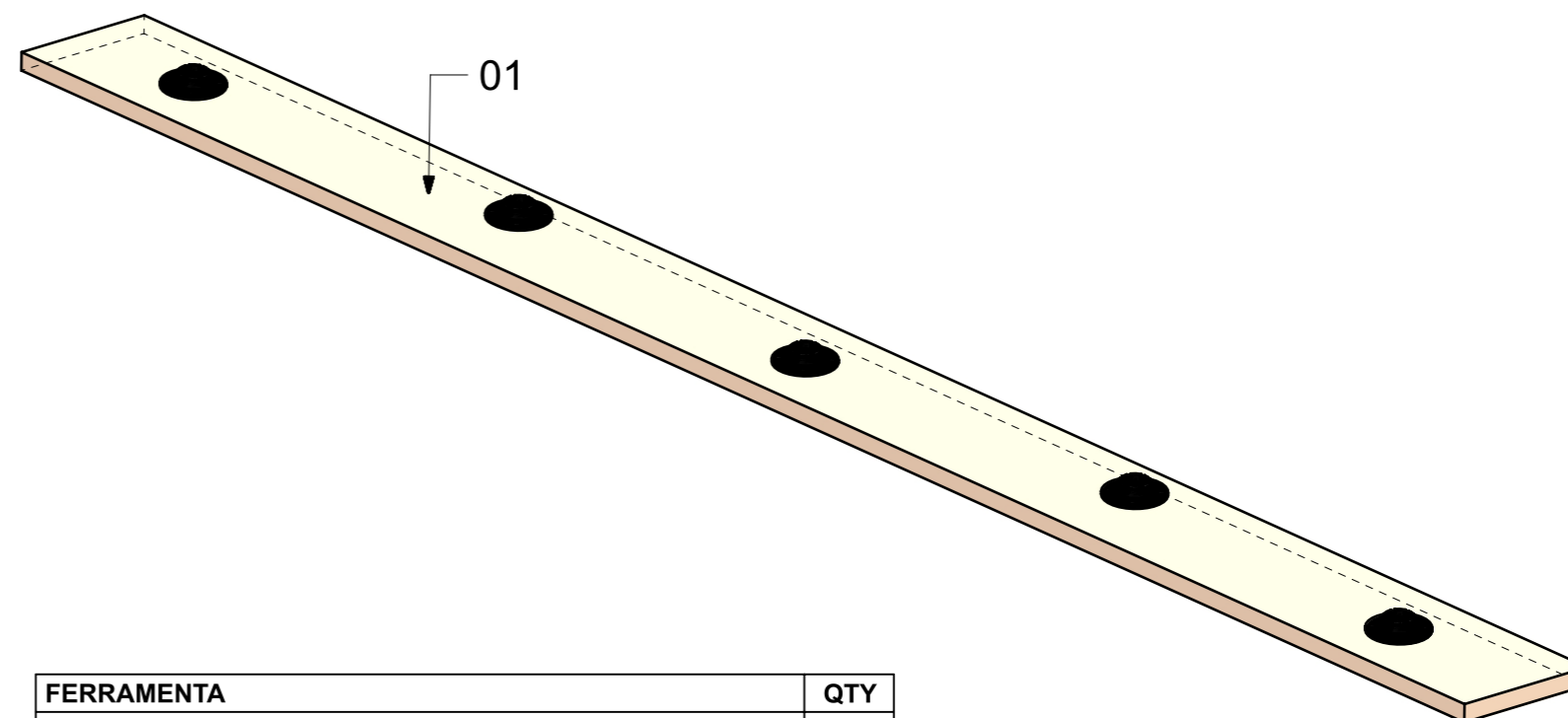

FERRAMENTA	QTY
FITLOCK M_MASCHERPA_3MM_6020202101	5

VERNICIATURA LASTRA/LACCATI:

● = VERNICIARE 1 LATO + FILI RASATI O BORDATI

NESSUN SIMBOLO = VERNICIARE 2 LATI + FILI RASATI O BORDATI

LOCALE	CODICE	DESCRIZIONE COMPONENTE	FINITURA	Q.TA
CABINA OSPITI DX	MD299_R01_RL01	RIV. PARETI	LASTRA SCURA	1

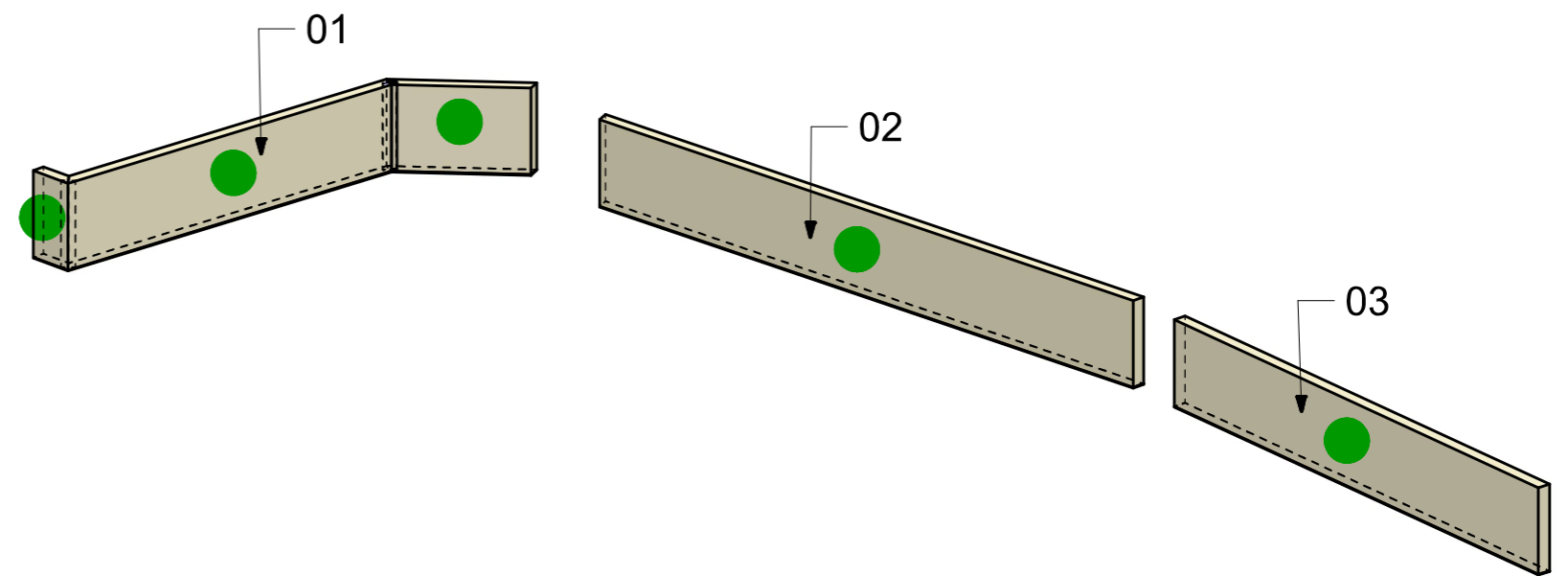
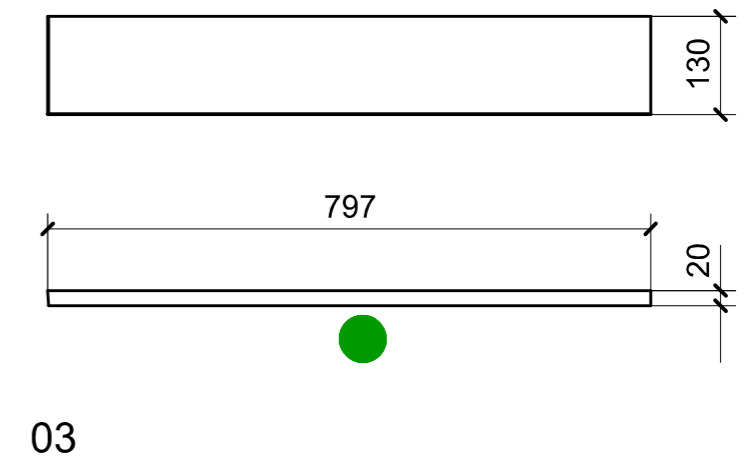
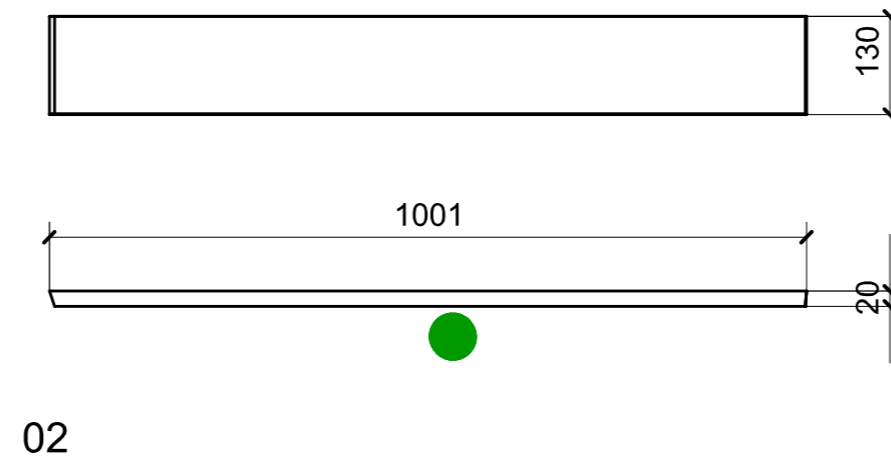
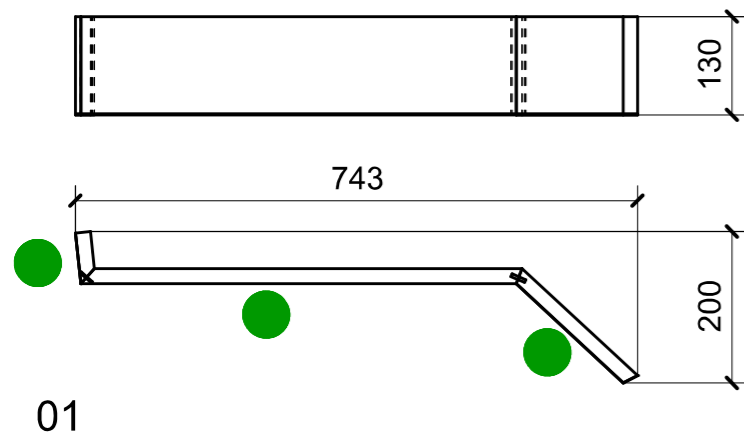

VERNICIATURA LASTRA/LACCATI:

● = VERNICIARE 1 LATO + FILI RASATI O BORDATI

NESSUN SIMBOLO = VERNICIARE 2 LATI + FILI RASATI O BORDATI