

LOCALE	CODICE	DESCRIZIONE COMPONENTE	FINITURA	Q.TA
CABINA MARINAIO	MD299_MG_MB01	VANO A GIORNO MURATA DX	LAMINATO CLEAF SABLE' S166	1

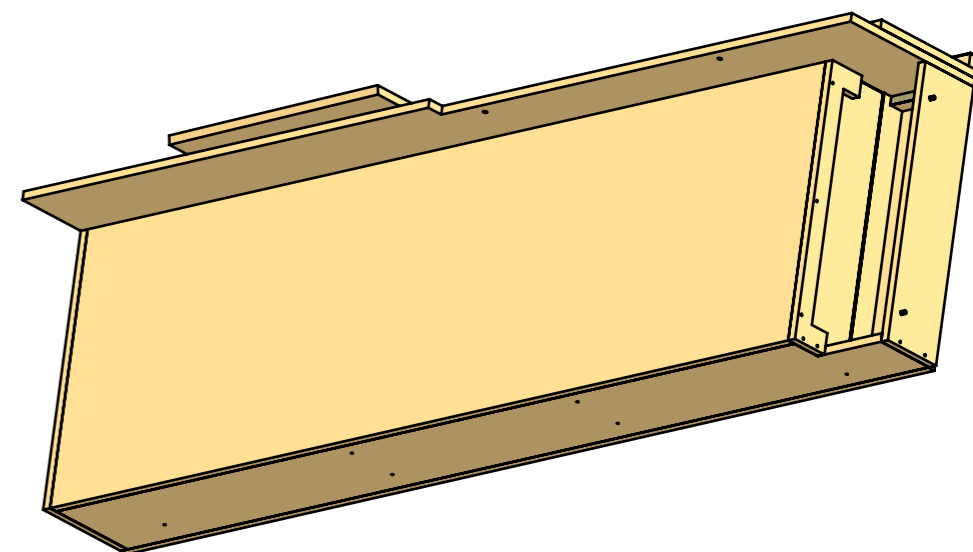

FERRAMENTA	QTY
BUSSOLA 6MA X 10 FORO DIAM.8	4
VITE 6MA X 25 TESTA BOMBATA	4

LOCALE	CODICE	DESCRIZIONE COMPONENTE	FINITURA	Q.TA
CABINA MARINAIO	MD299_MB01	VANO A GIORNO MURATA DX	LAMINATO CLEAF SABLE' S166	1

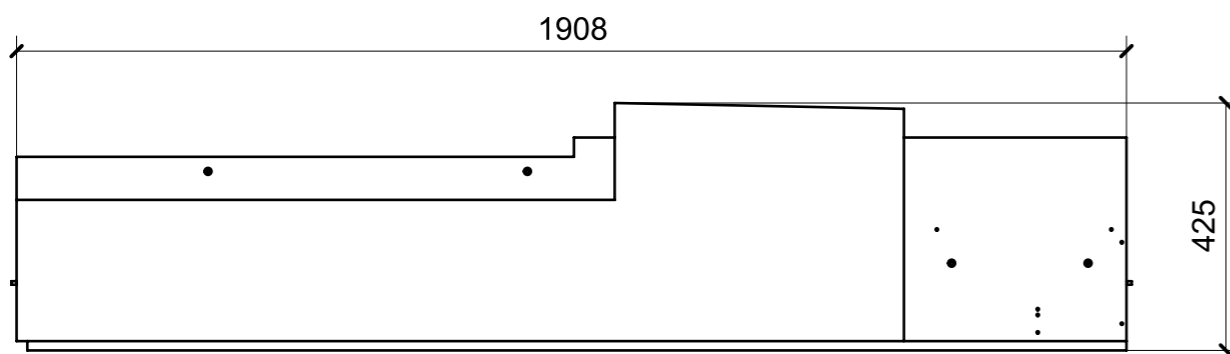
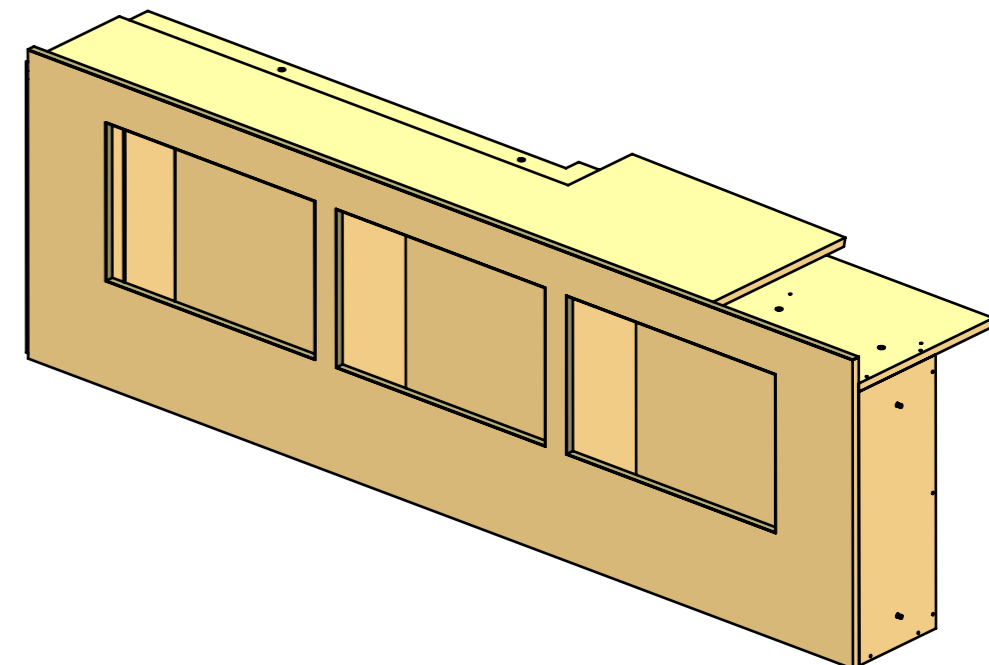
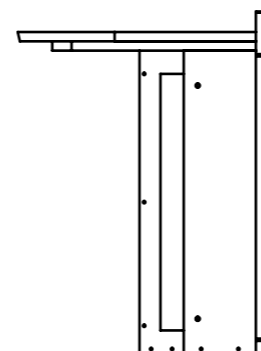
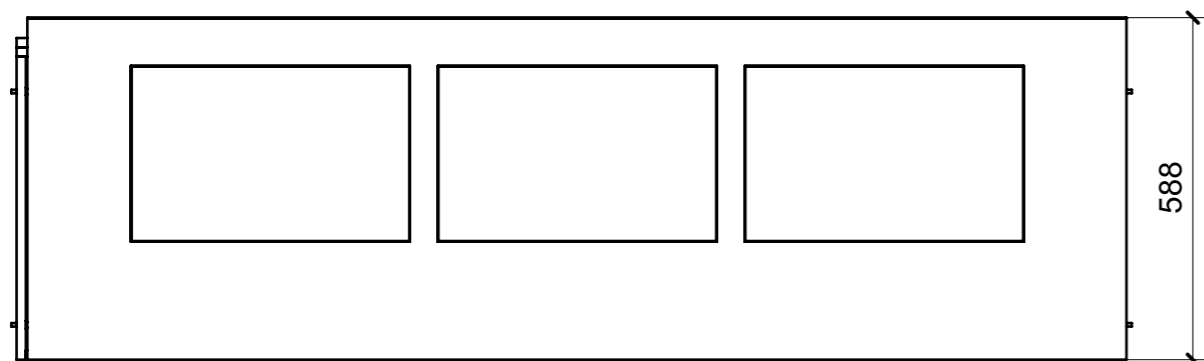
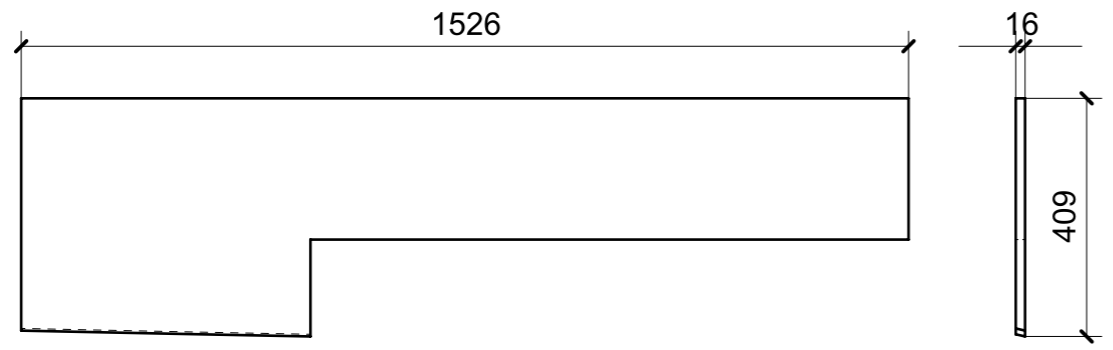
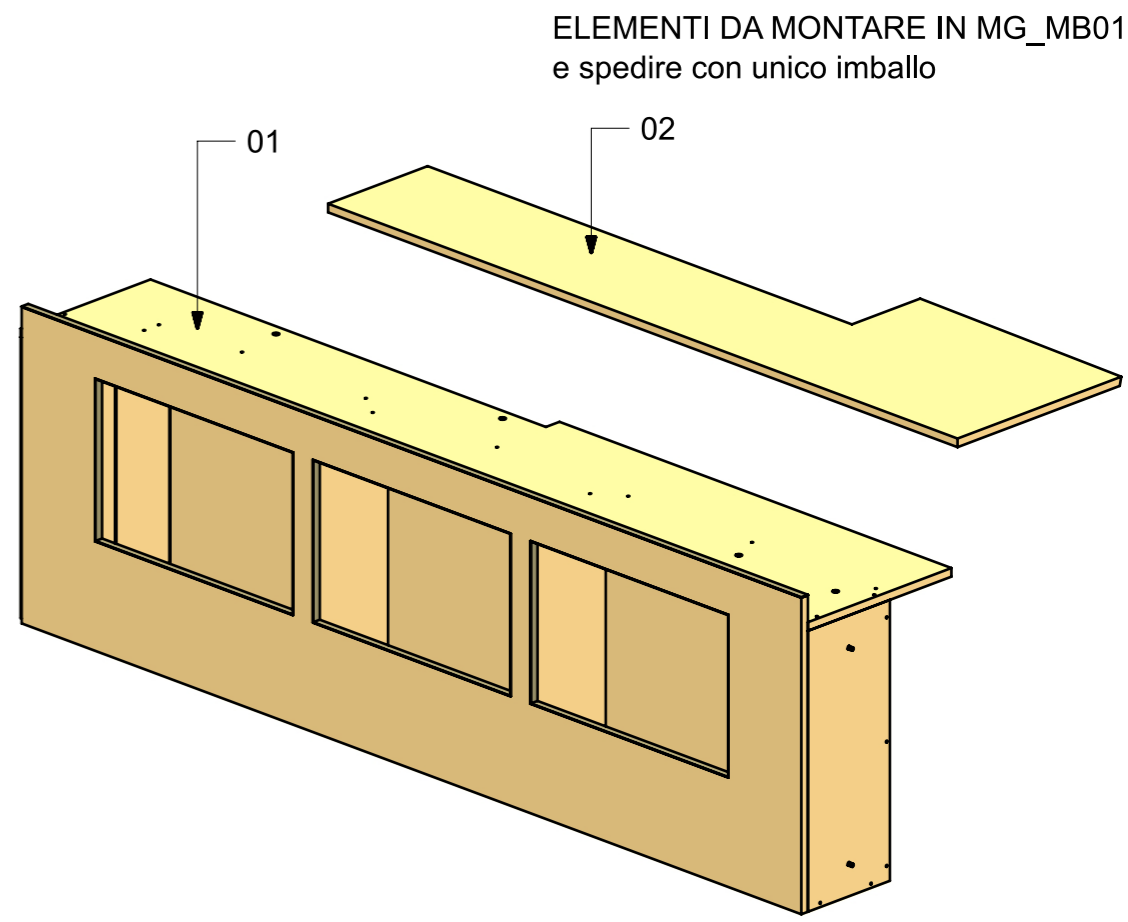
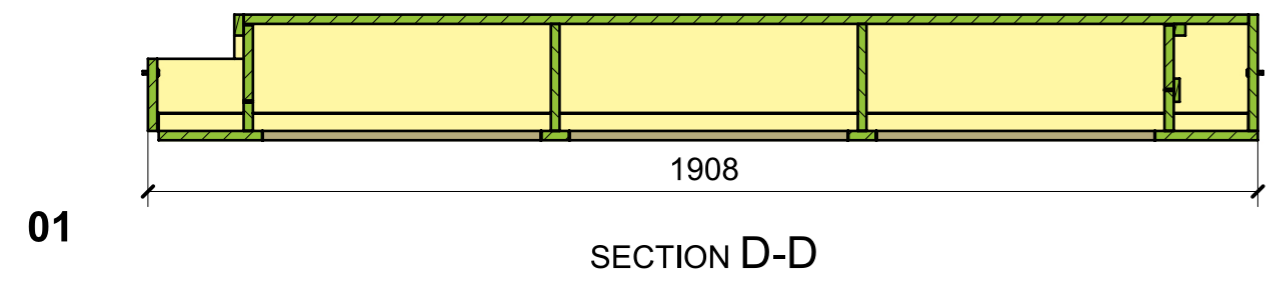
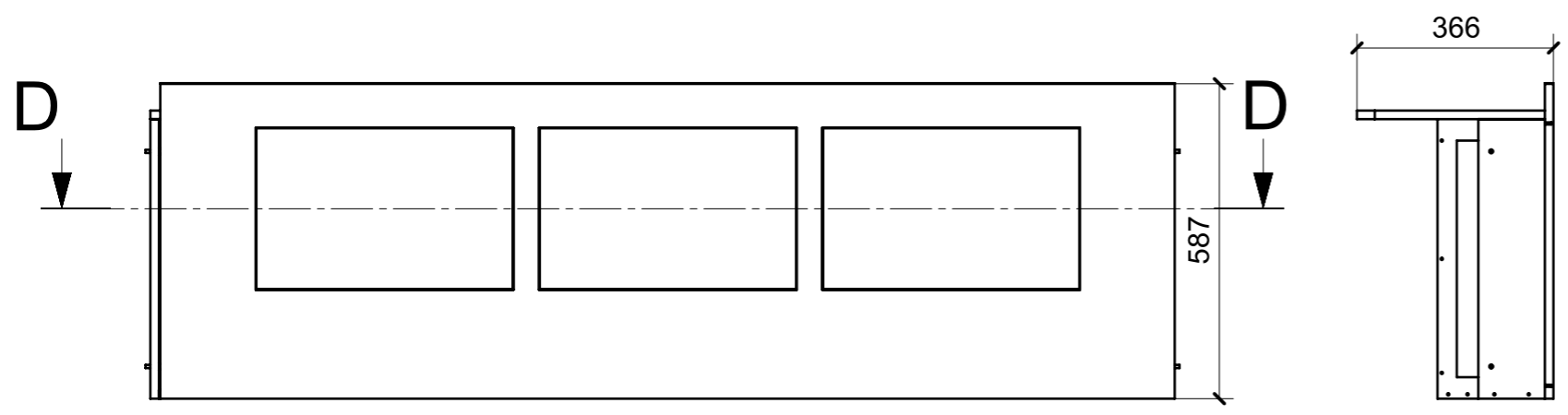

02

FERRAMENTA	QTY
BUSSOLA 6MA X 10 FORO DIAM.8	4
VITE 6MA X 25 TESTA BOMBATA	4

LOCALE	CODICE	DESCRIZIONE COMPONENTE	FINITURA	Q.TA
CABINA MARINAIO	MD299_MG_MD01	PENSILE MURATA DX POPPA	LAMINATO CLEAF SABLE' S166/OKUME' GREZZO	1

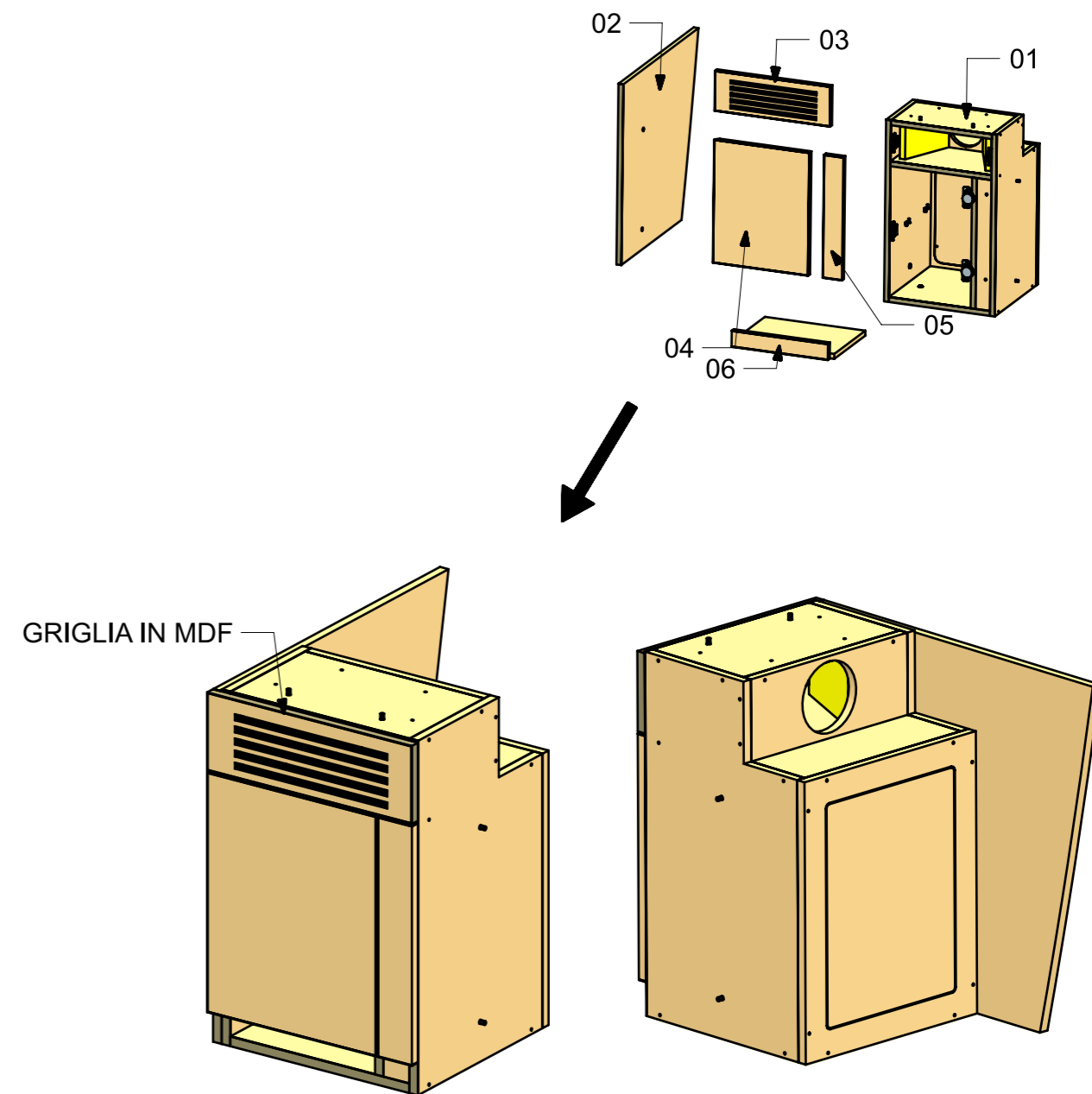
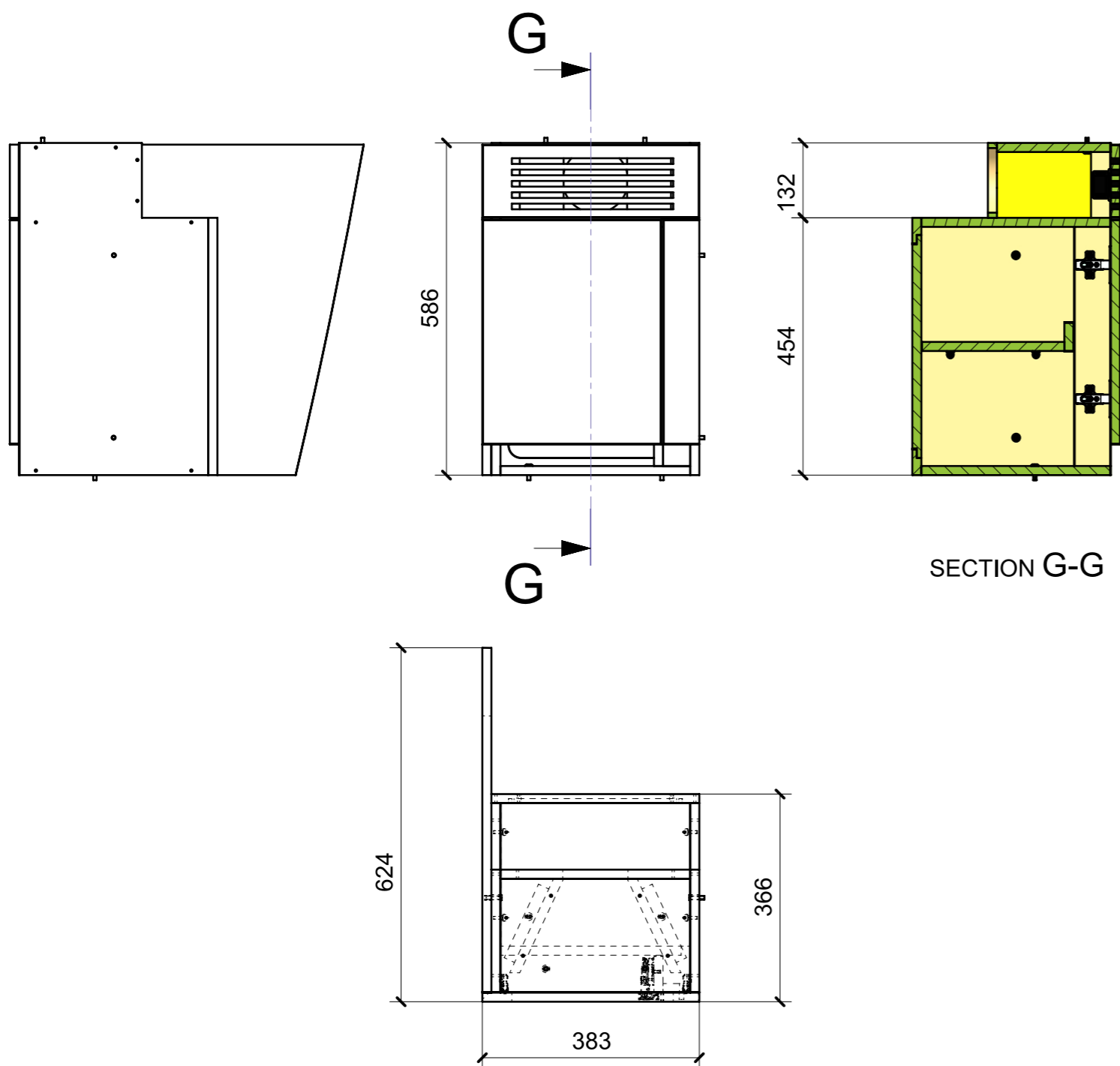

FERRAMENTA	QTY
BASE_6_HAFELE_329_84_026	4
BUSSOLA 5MA ANKOR BORGHI X CERNIERA PIANA	16
BUSSOLA 6MA X 10 FORO DIAM.8	4
CERNIERA 94° PIANA AMMORTIZZATA_HAFELE_329_49_310	4
CHIUSURA A SPINTA_TECHNOPARTNER_SOU C3-203	6
REGGRIPIANO 1PERNO 1FORO_FBC_00257770	8
VITE 4MAX8 ANKOR BORGHI X CERNIERA PIANA	16
VITE 6MA X 25 TESTA BOMBATA	16

LOCALE	CODICE	DESCRIZIONE COMPONENTE	FINITURA	Q.TA
CABINA MARINAIO	MD299_MD01	PENSILE MURATA DX POPPA	LAMINATO CLEAF SABLE' S166/OKUME' GREZZO	1

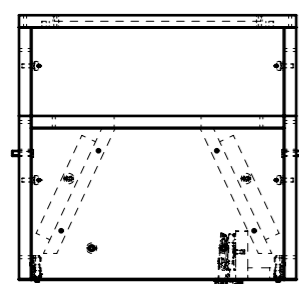
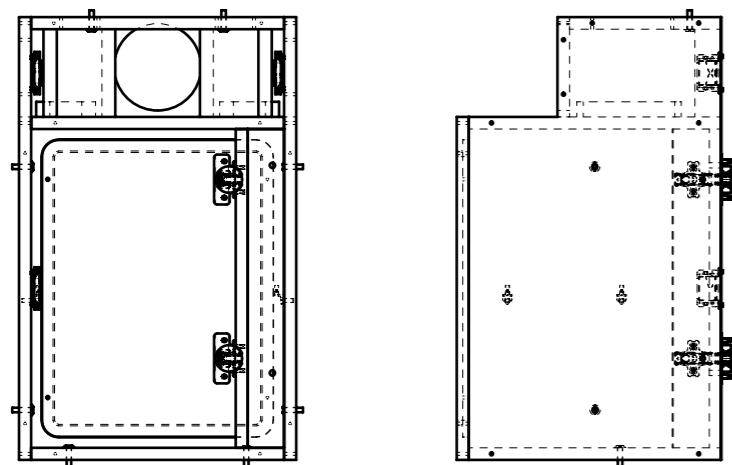

01

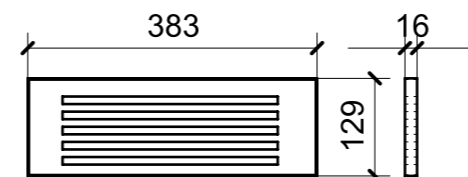

GRIGLIA IN MDF

03

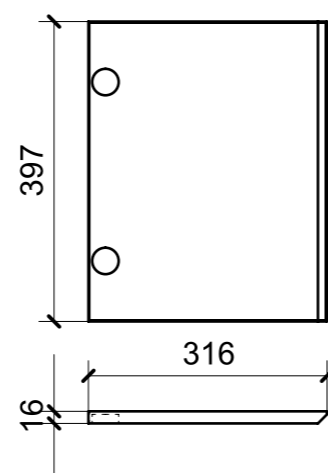

04

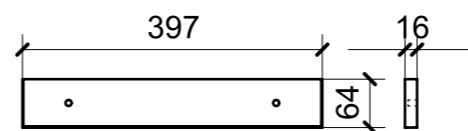

05

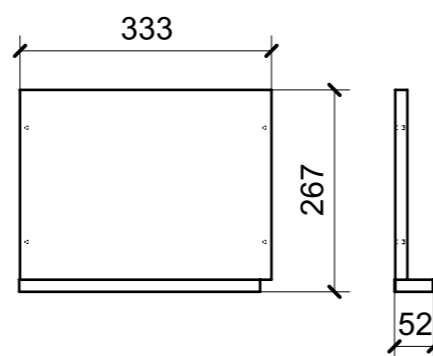

06

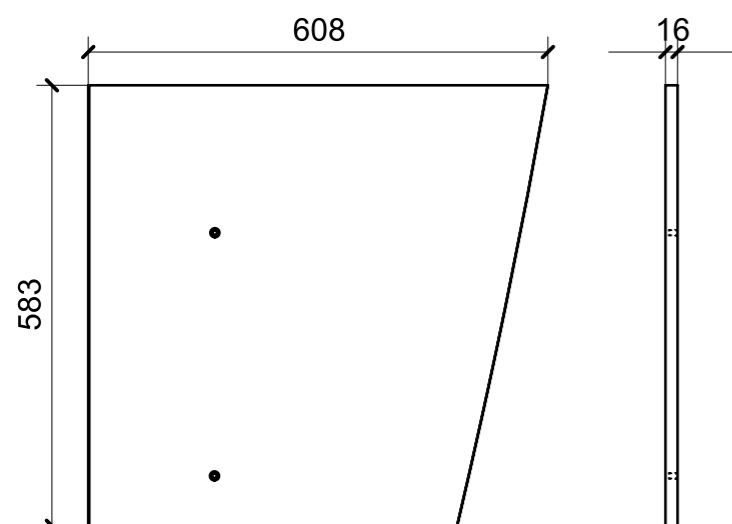

02

ELEMENTI DA MONTARE IN MG_MD01
e spedire con unico imballo

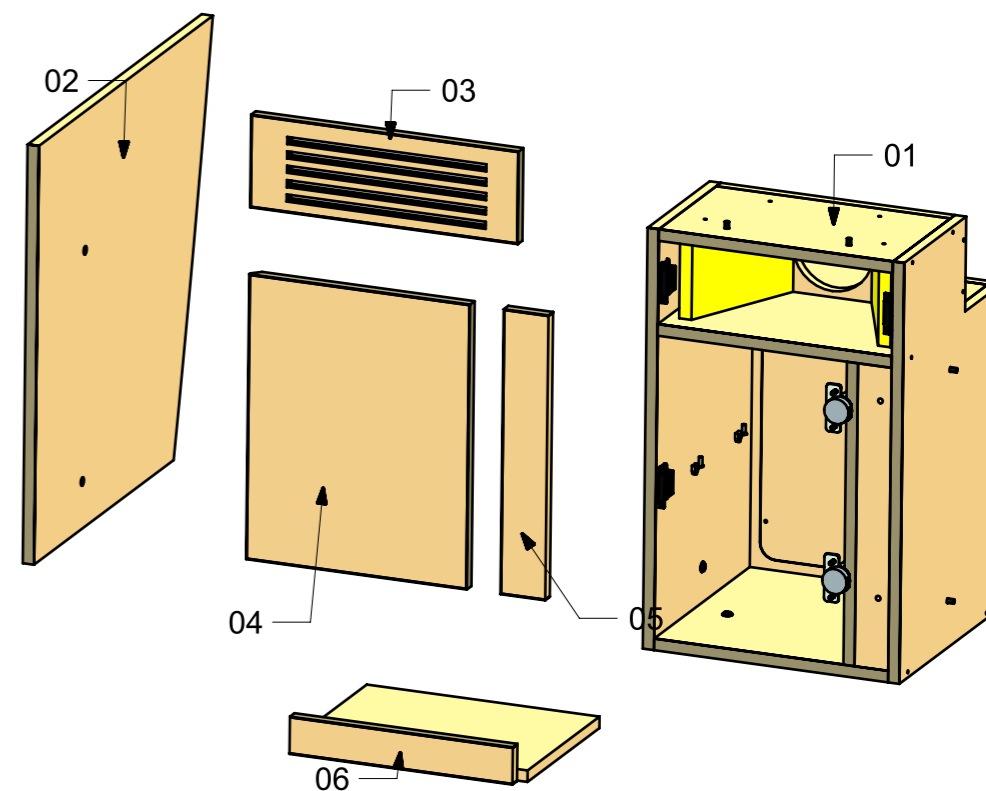
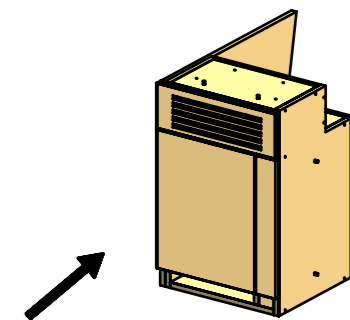

FERRAMENTA	QTY
BASE_6_HAFELE_329_84_026	4
BUSSOLA 5MA ANKOR BORGHI X CERNIERA PIANA	16
BUSSOLA 6MA X 10 FORO DIAM.8	4
CERNIERA 94° PIANA AMMORTIZZATA_HAFELE_329_49_310	4
CHIUSURA A SPINTA_TECHNOPARTNER_SOU C3-203	6
REGGRIPIANO 1PERNO 1FORO_FBC_00257770	8
VITE 4MAX8 ANKOR BORGHI X CERNIERA PIANA	16
VITE 6MA X 25 TESTA BOMBATA	16

LOCALE	CODICE	DESCRIZIONE COMPONENTE	FINITURA	Q.TA
CABINA MARINAIO	MD299_MG_ME01	MOBILE DUE ANTE POPPA	LAMINATO CLEAF SABLE' S166	1

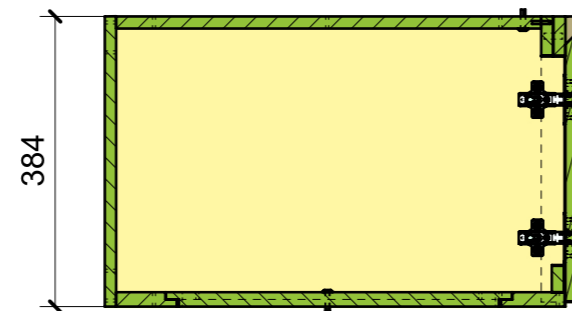
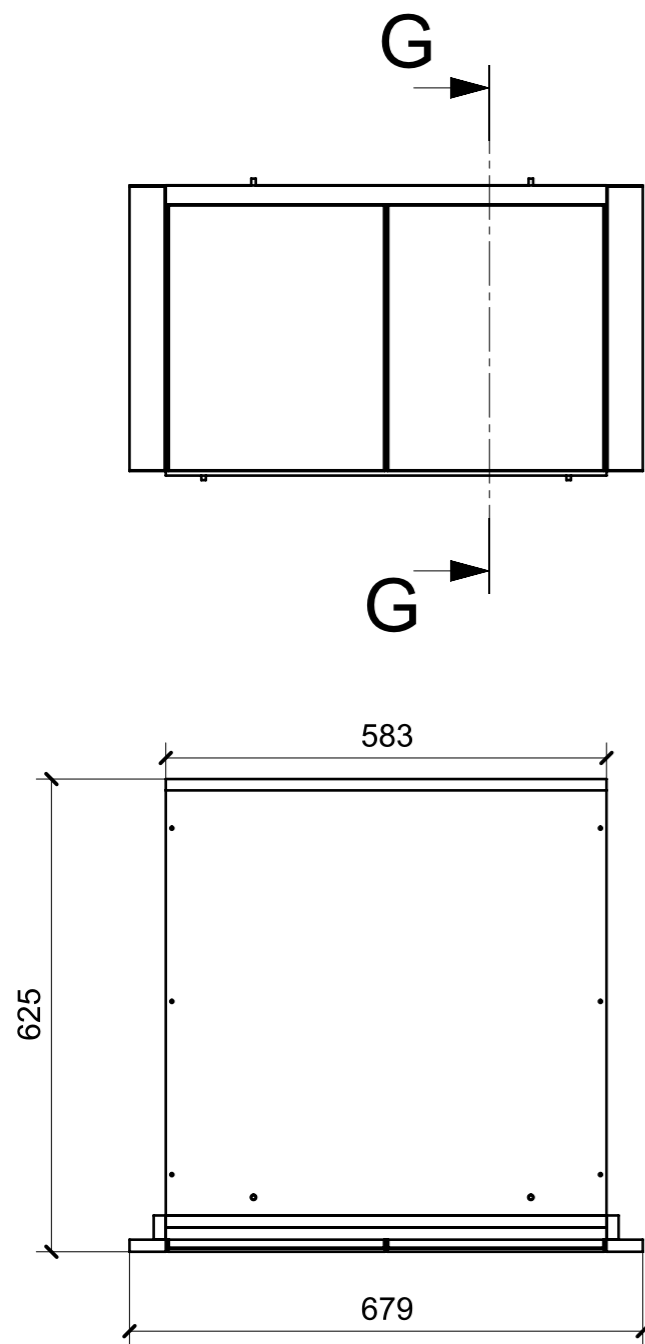

SECTION G-G

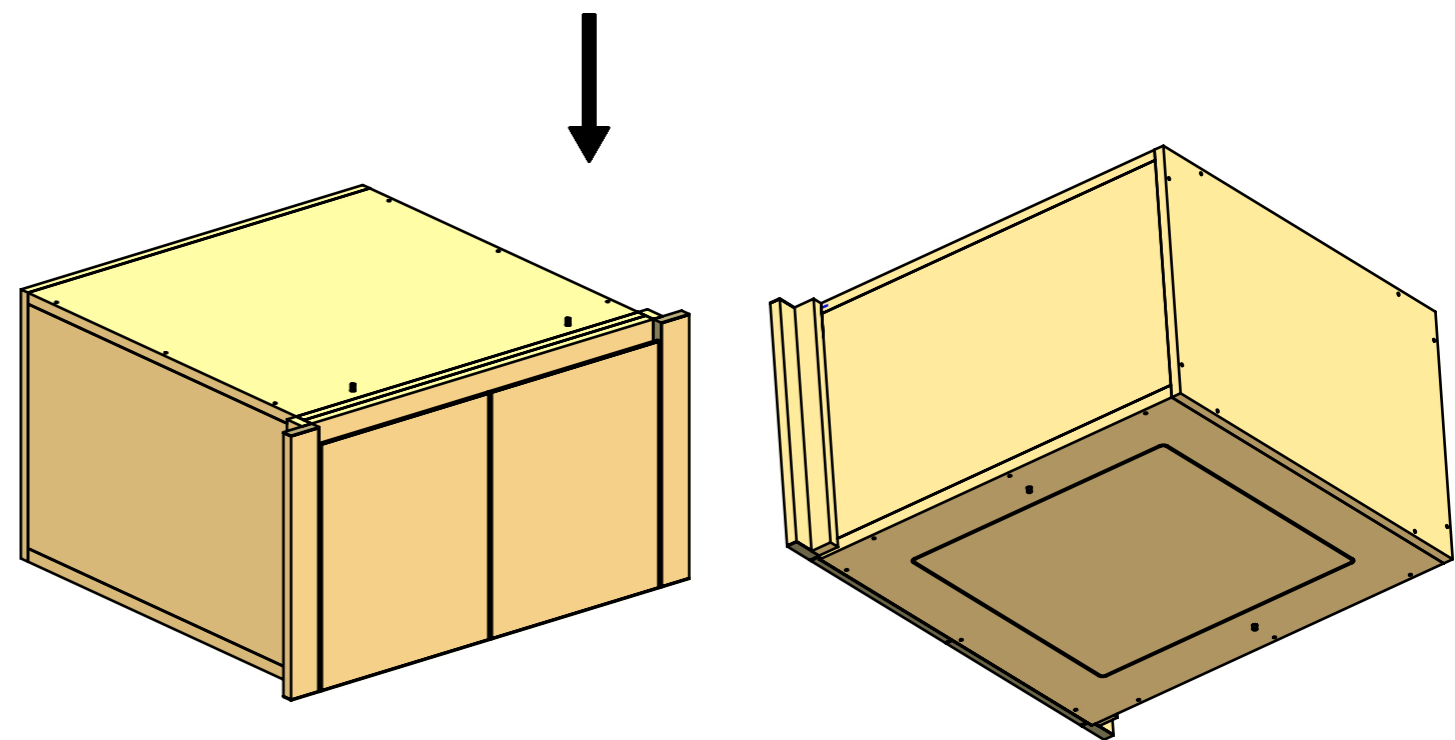
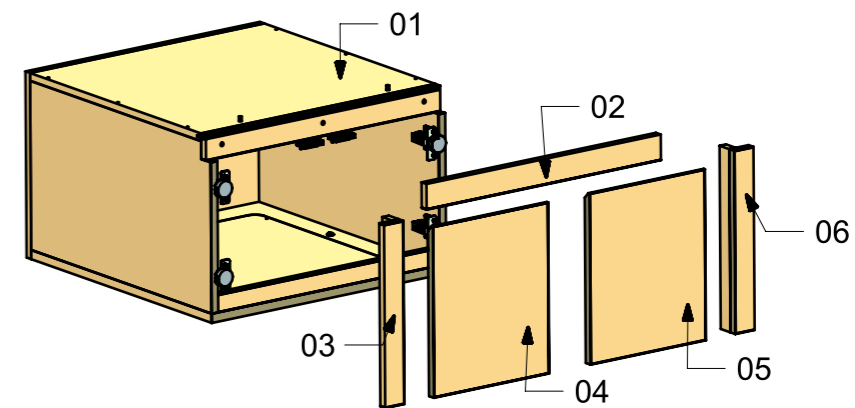

FERRAMENTA	QTY
BASE_6_HAFELE_329_84_026	4
BUSSOLA 5MA ANKOR BORGHI X CERNIERA PIANA	16
CERNIERA 94° PIANA AMMORTIZZATA_HAFELE_329_49_310	4
CHIUSURA A SPINTA_TECHNOPARTNER_SOU C3-203	2
FM INCASSO_ITALVIPLA_973_FMPC_F1A	2
MS INCASSO_ITALVIPLA_972_FMPC_M1B	2
VITE 4MAX8 ANKOR BORGHI X CERNIERA PIANA	16
VITE 6MA X 25 TESTA BOMBATA	4

LOCALE	CODICE	DESCRIZIONE COMPONENTE	FINITURA	Q.TA
CABINA MARINAIO	MD299_ME01	MOBILE DUE ANTE POPPA	LAMINATO CLEAF SABLE' S166/OKUME' GREZZO	1

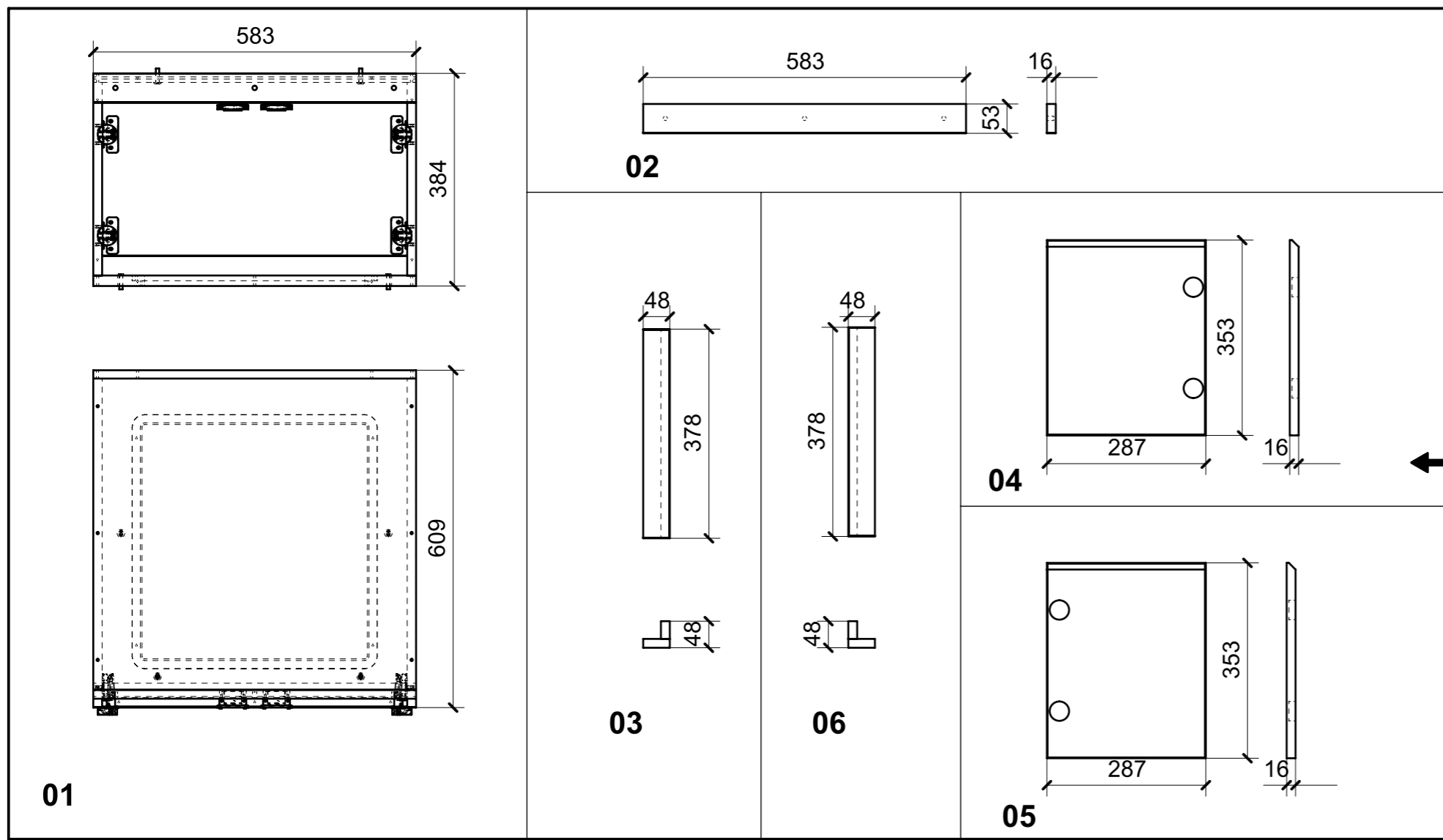

ELEMENTI DA MONTARE IN MG_ME01
e spedire con unico imballo

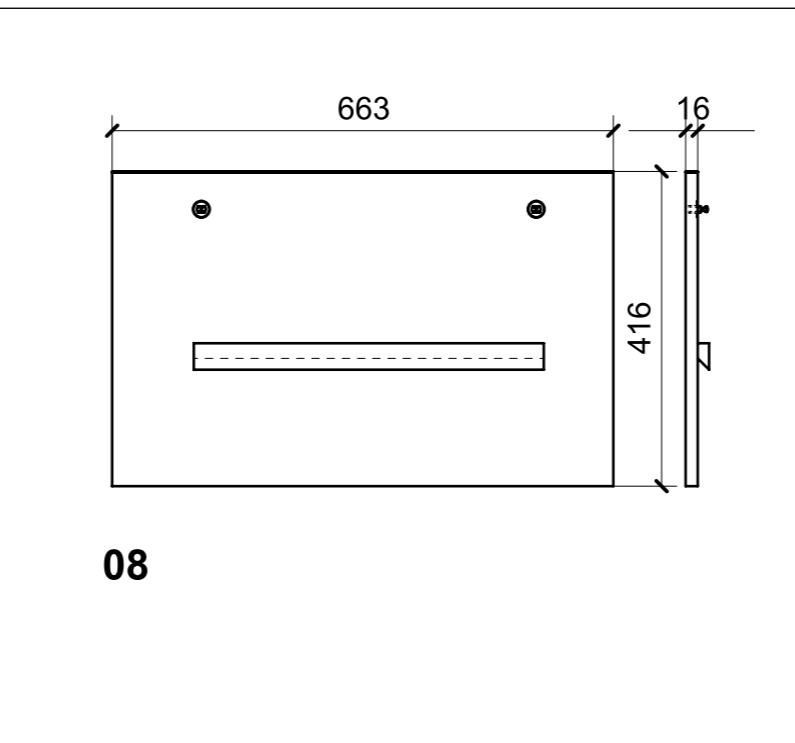
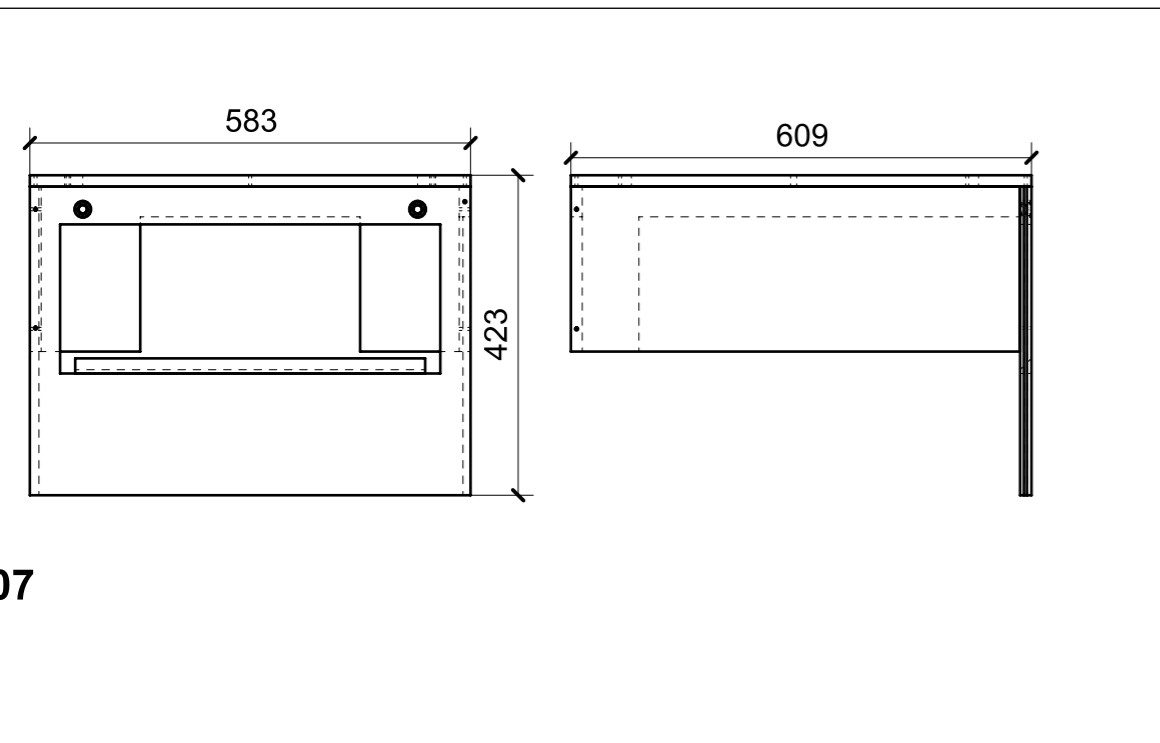
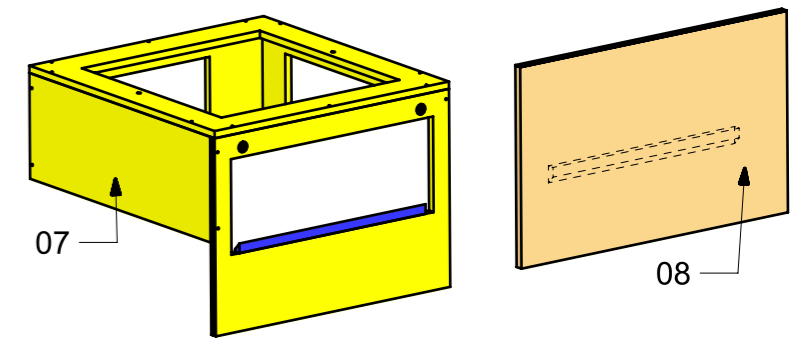
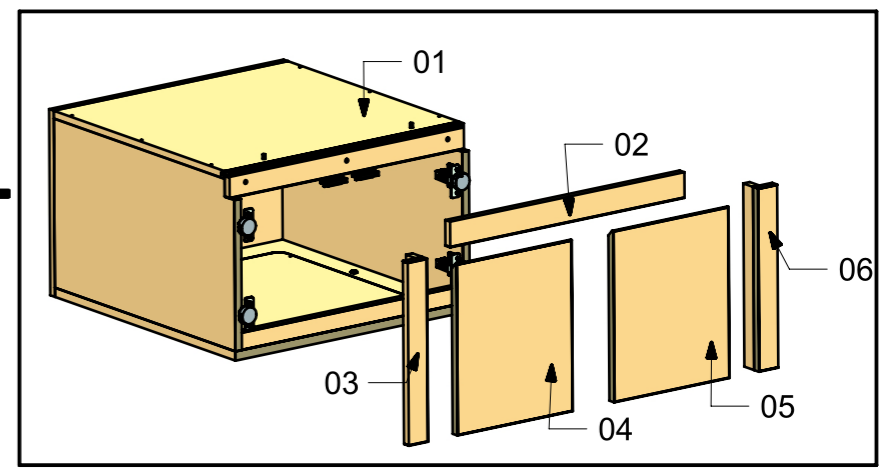

FERRAMENTA	QTY
BASE_6_HAFELE_329_84_026	4
BUSSOLA 5MA ANKOR BORGHI X CERNIERA PIANA	16
CERNIERA 94° PIANA AMMORTIZZATA_HAFELE_329_49_310	4
CHIUSURA A SPINTA_TECHNOPARTNER_SOU C3-203	2
FM INCASSO_ITALVIPLA_973_FMPC_F1A	2
MS INCASSO_ITALVIPLA_972_FMPC_M1B	2
VITE 4MAX8 ANKOR BORGHI X CERNIERA PIANA	16
VITE 6MA X 25 TESTA BOMBATA	4

LOCALE	CODICE	DESCRIZIONE COMPONENTE	FINITURA	Q.TA
CABINA MARINAIO	MD299_MEE01	VANO A GIORNO ELETRICI	LAMINATO CLEAF SABLE' S166	1

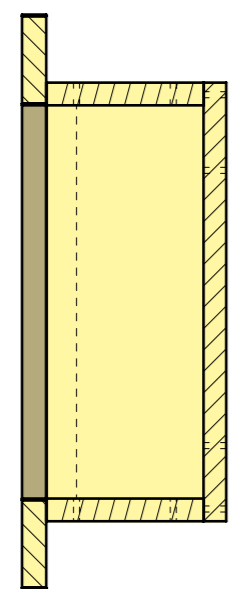

SECTION D-D

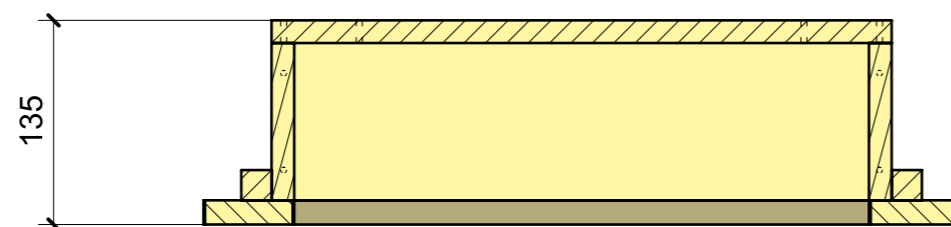
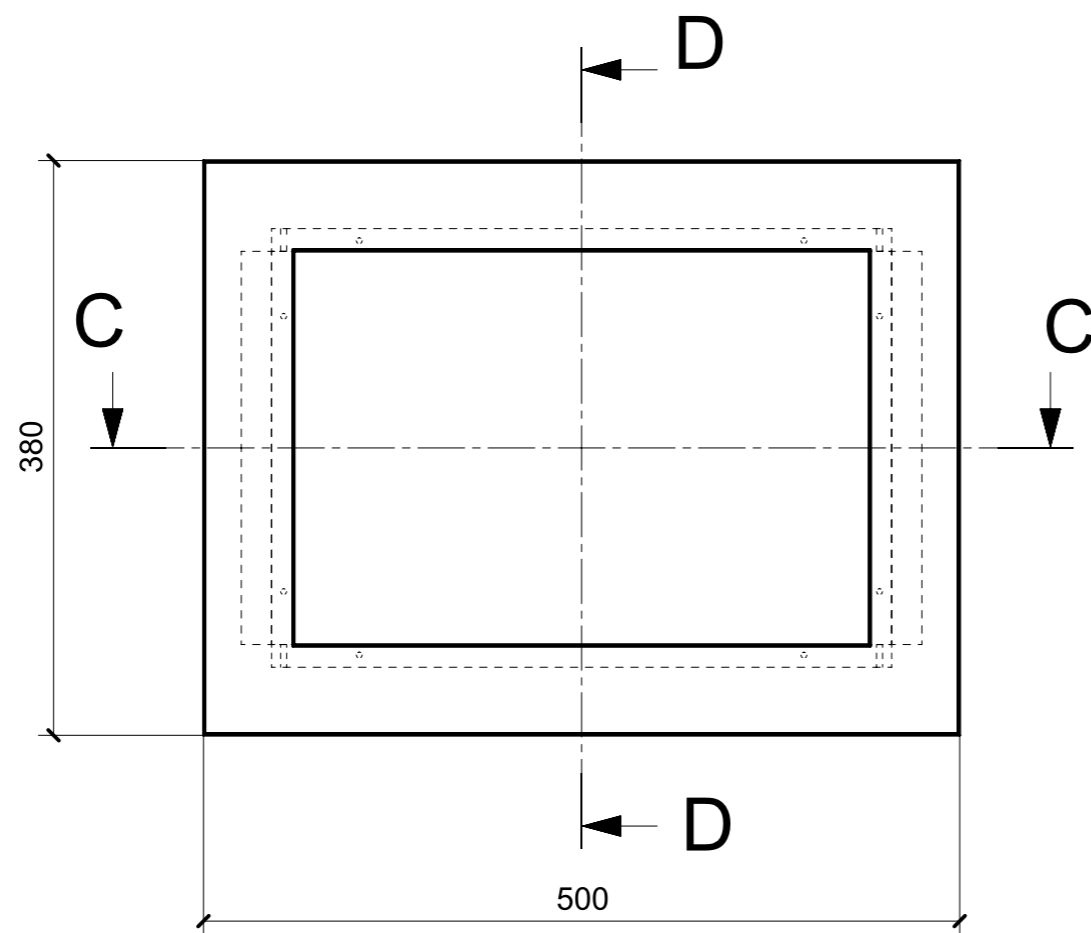

SECTION C-C

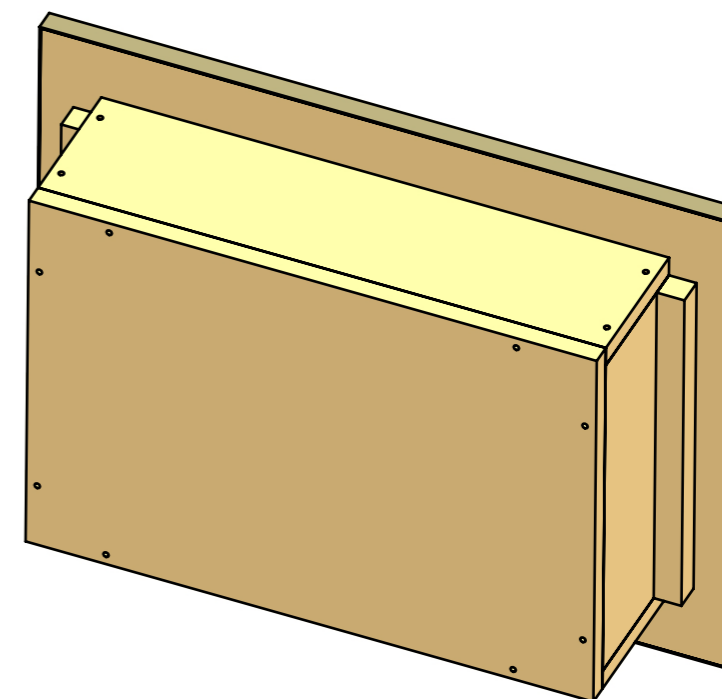
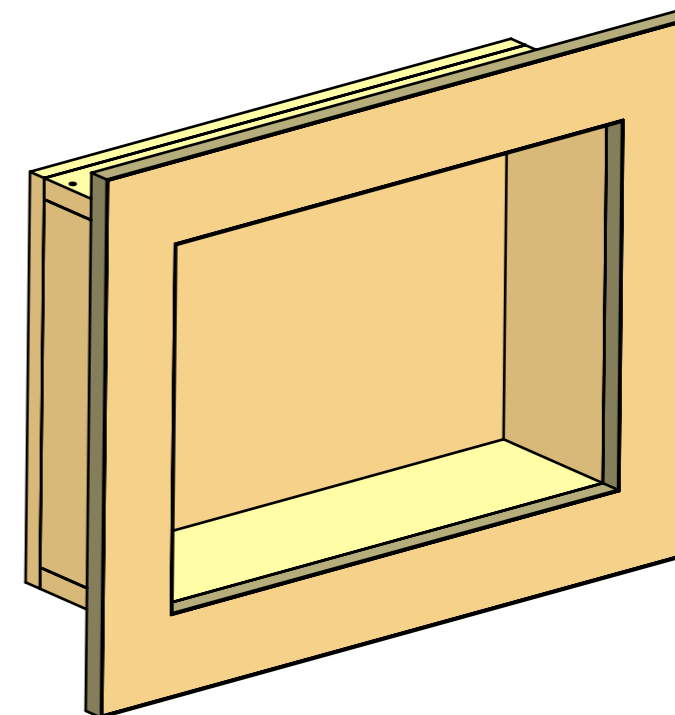

LOCALE	CODICE	DESCRIZIONE COMPONENTE	FINITURA	Q.TA
CABINA MARINAIO	MD299_MF01	RIVESTIMENTO PARETE LETTO POPPA	LAMINATO CLEAF SABLE' S166/OKUME' GREZZO	1

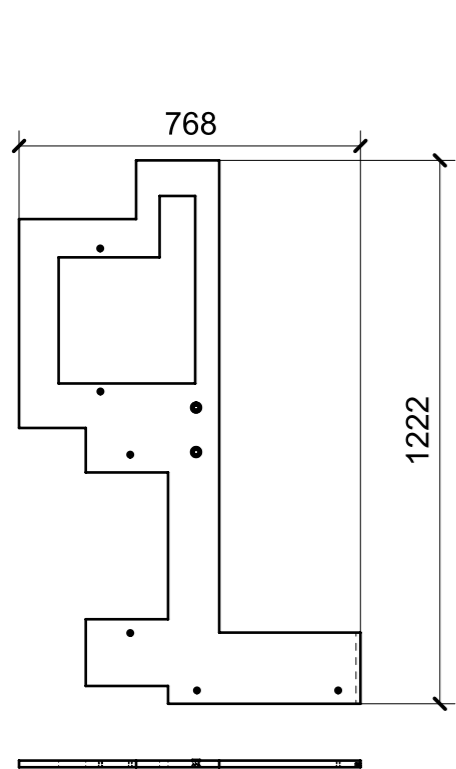

01

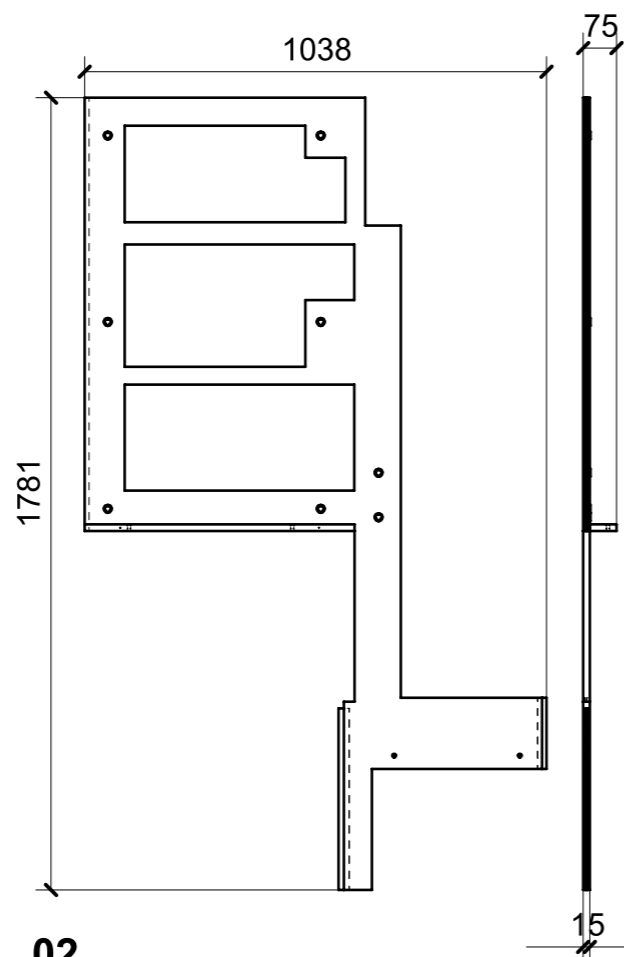

02

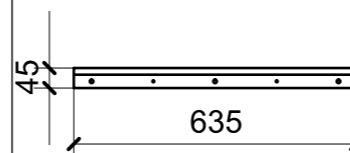

03

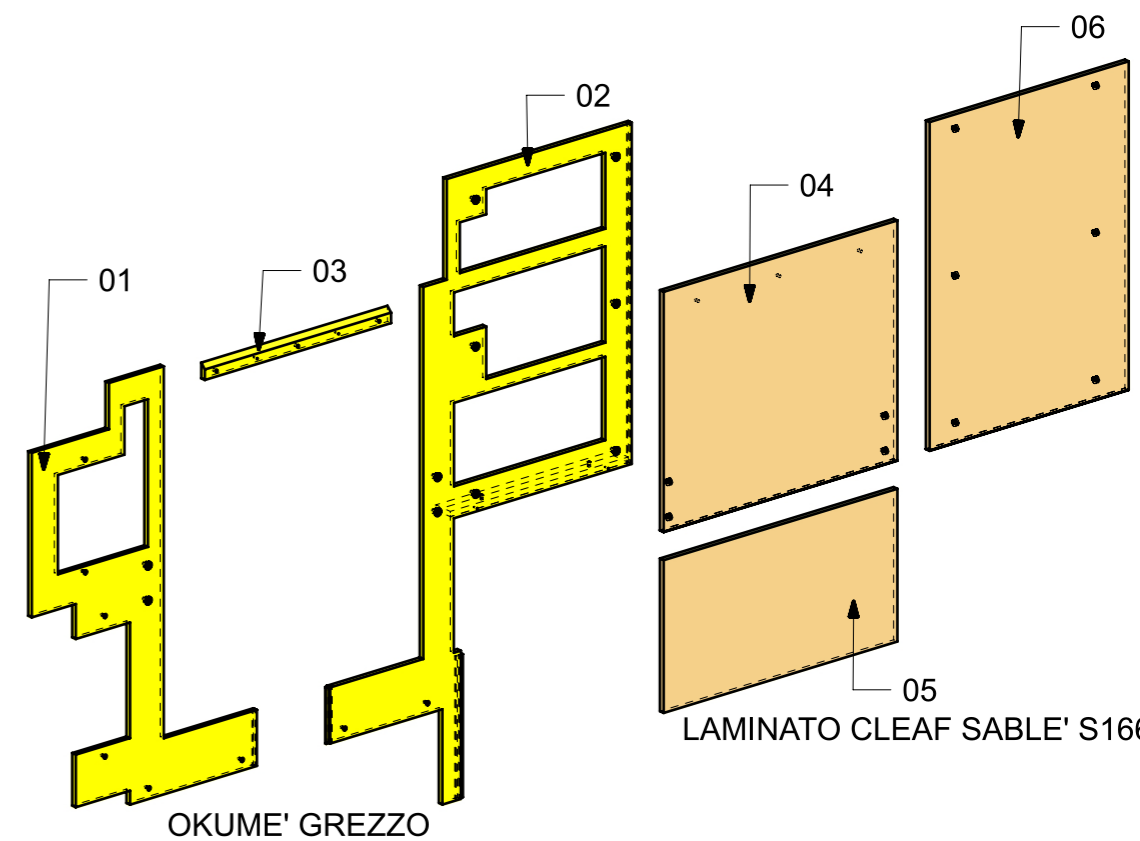

OKUME' GREZZO

LAMINATO CLEAF SABLE' S166

FERRAMENTA	QTY
BUSSOLA 6MA X 10 FORO DIAM.8	10
FM INCASSO_ITALVIPLA_973_FMPC_F1A	10
MS INCASSO_ITALVIPLA_972_FMPC_M1B	10

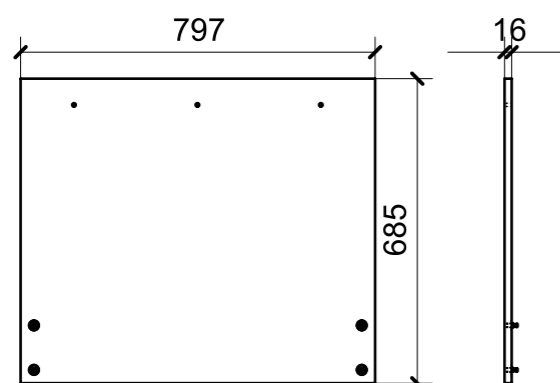

04

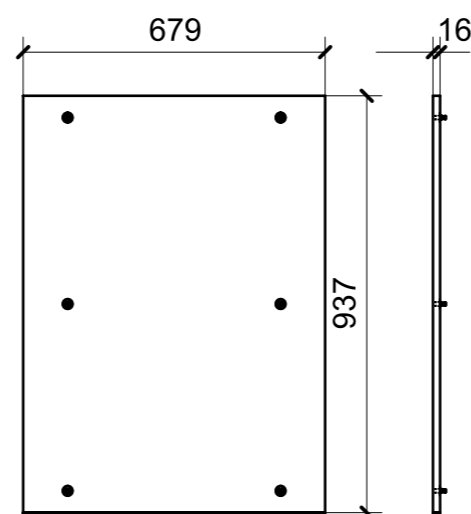

05

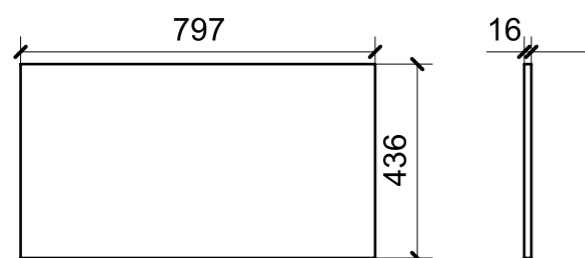

06

LOCALE	CODICE	DESCRIZIONE COMPONENTE	FINITURA	Q.TA
CABINA MARINAIO	MD299_MG01	RIVESTIMENTO PARETE LETTO PRUA	LAMINATO CLEAF SABLE' S166/OKUME' GREZZO	1

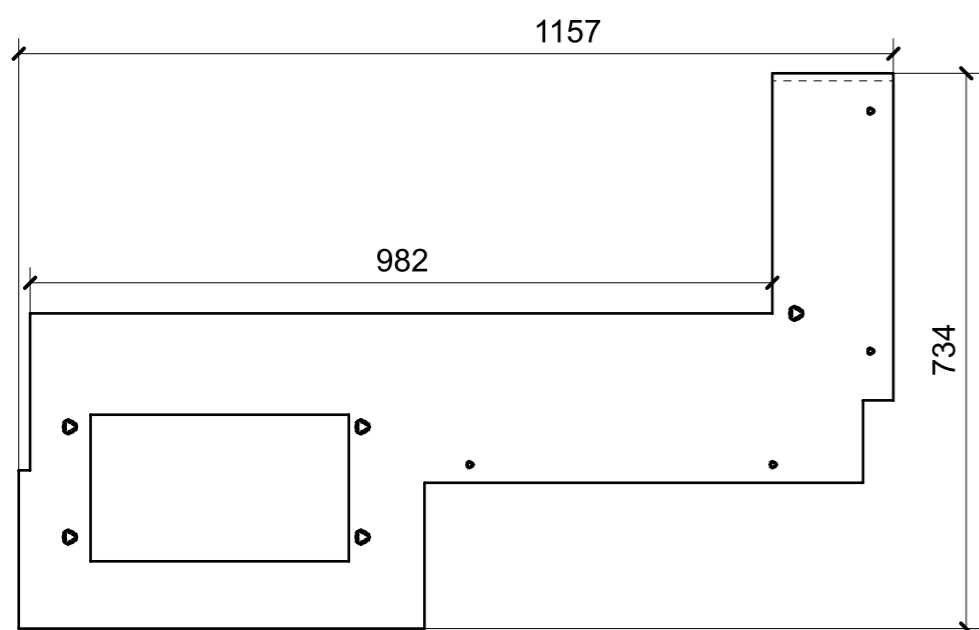

FERRAMENTA	QTY
BUSSOLA 6MA X 10 FORO DIAM.8	4
FM INCASSO_ITALVIPLA_973_FMPC_F1A	5

01

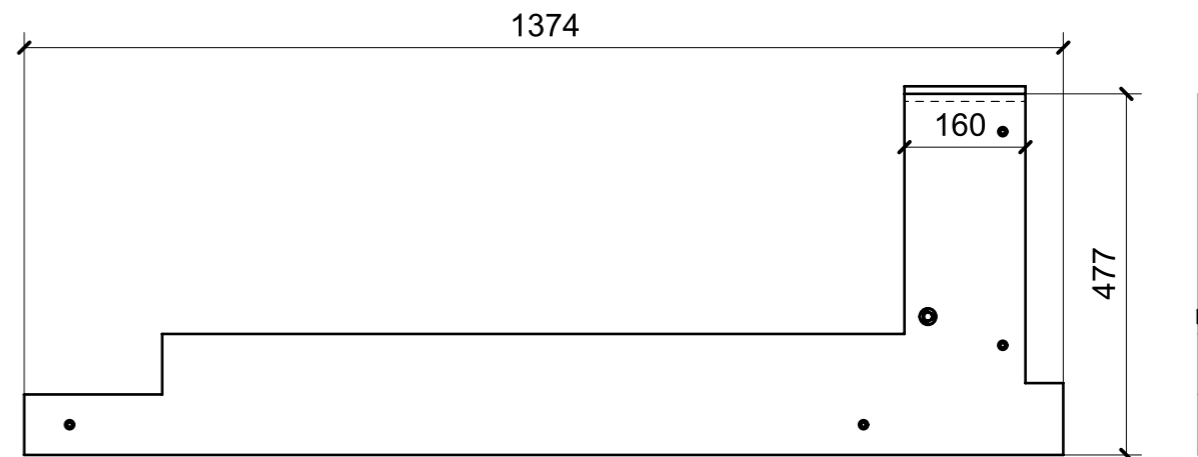

02

FERRAMENTA	QTY
BUSSOLA 6MA X 10 FORO DIAM.8	4
FM INCASSO_ITALVIPLA_973_FMPC_F1A	1

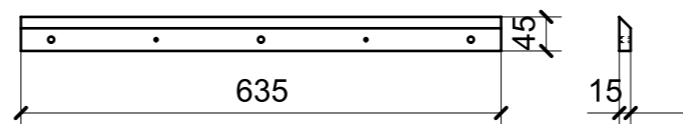

03

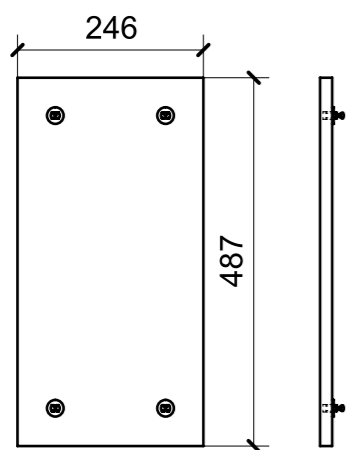

04

FERRAMENTA	QTY
MS INCASSO_ITALVIPLA_972_FMPC_M1B	4

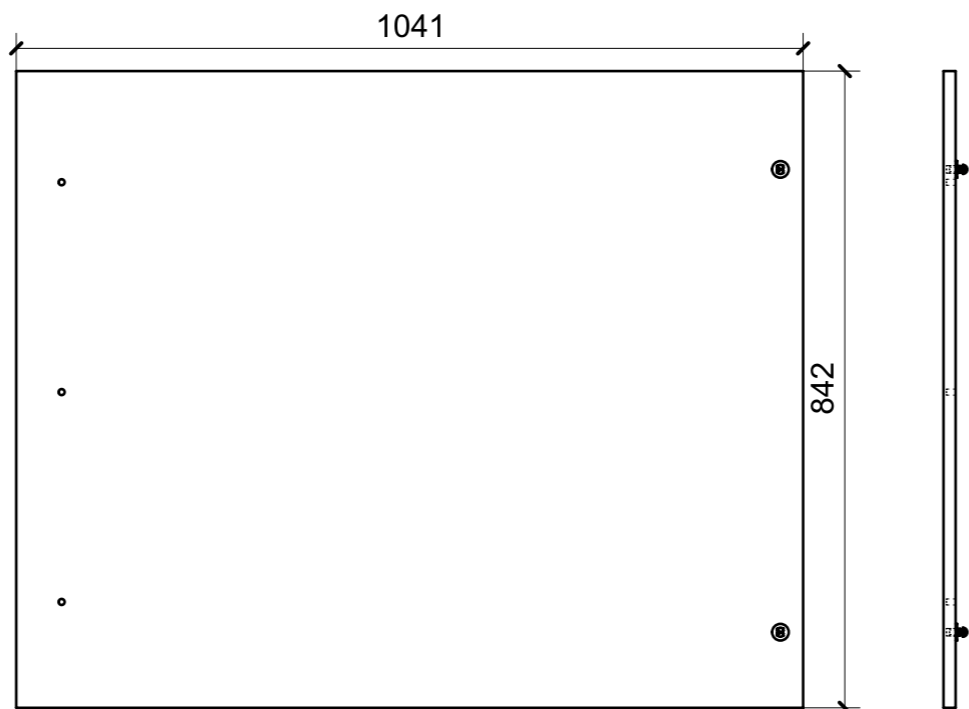

05

FERRAMENTA	QTY
MS INCASSO_ITALVIPLA_972_FMPC_M1B	2

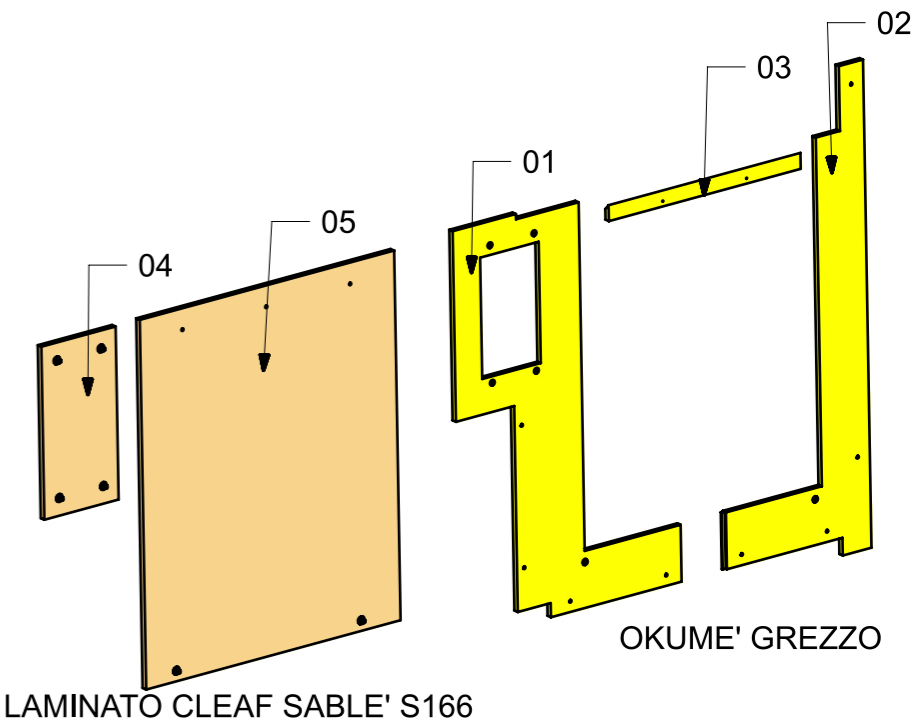

LAMINATO CLEAF SABLE' S166

OKUME' GREZZO

FERRAMENTA	QTY
BUSSOLA 6MA X 10 FORO DIAM.8	8
FM INCASSO_ITALVIPLA_973_FMPC_F1A	6
MS INCASSO_ITALVIPLA_972_FMPC_M1B	6

LOCALE	CODICE	DESCRIZIONE COMPONENTE	FINITURA	Q.TA
CABINA MARINAIO	MD299_MJ01	ARMADIO LAVASCIUGA	LAMINATO CLEAF SABLE' S166/GREZZO	1

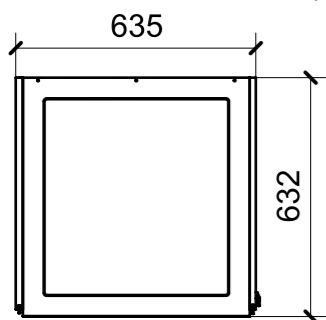
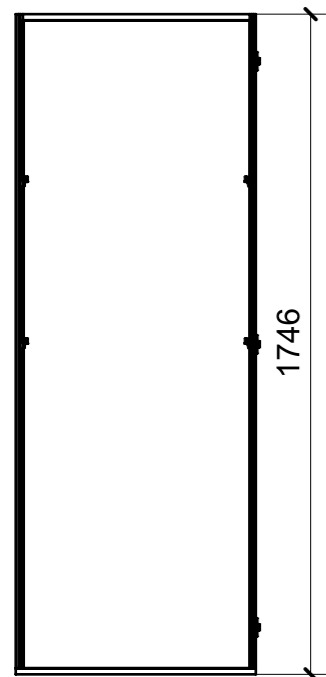

01

FERRAMENTA	QTY
REGGRIPIANO 1PERNO 1FORO_FBC_00257770	8
KEKU ESTRAZIONE FRONTALE PARTE TELAIO AS_HAFELE_262_50_368	3

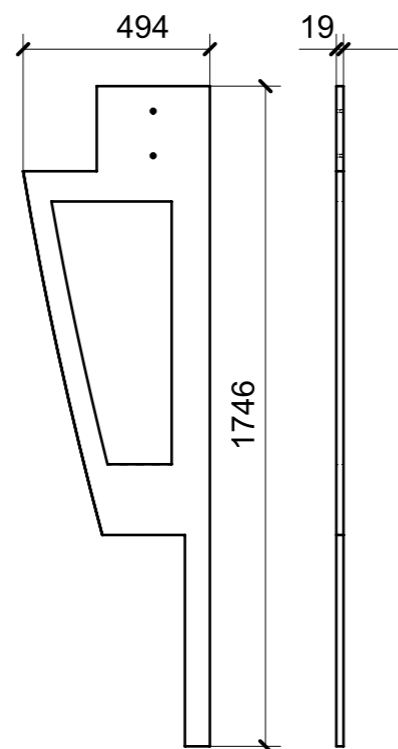

02

FERRAMENTA	QTY
BUSSOLA 6MA X 10 FORO DIAM.8	2

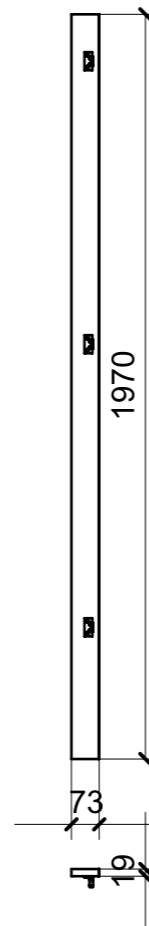

03

FERRAMENTA	QTY
KEKU ESTRAZIONE FRONTALE PARTE PANNELLO AS_HAFELE_262_50_359	3

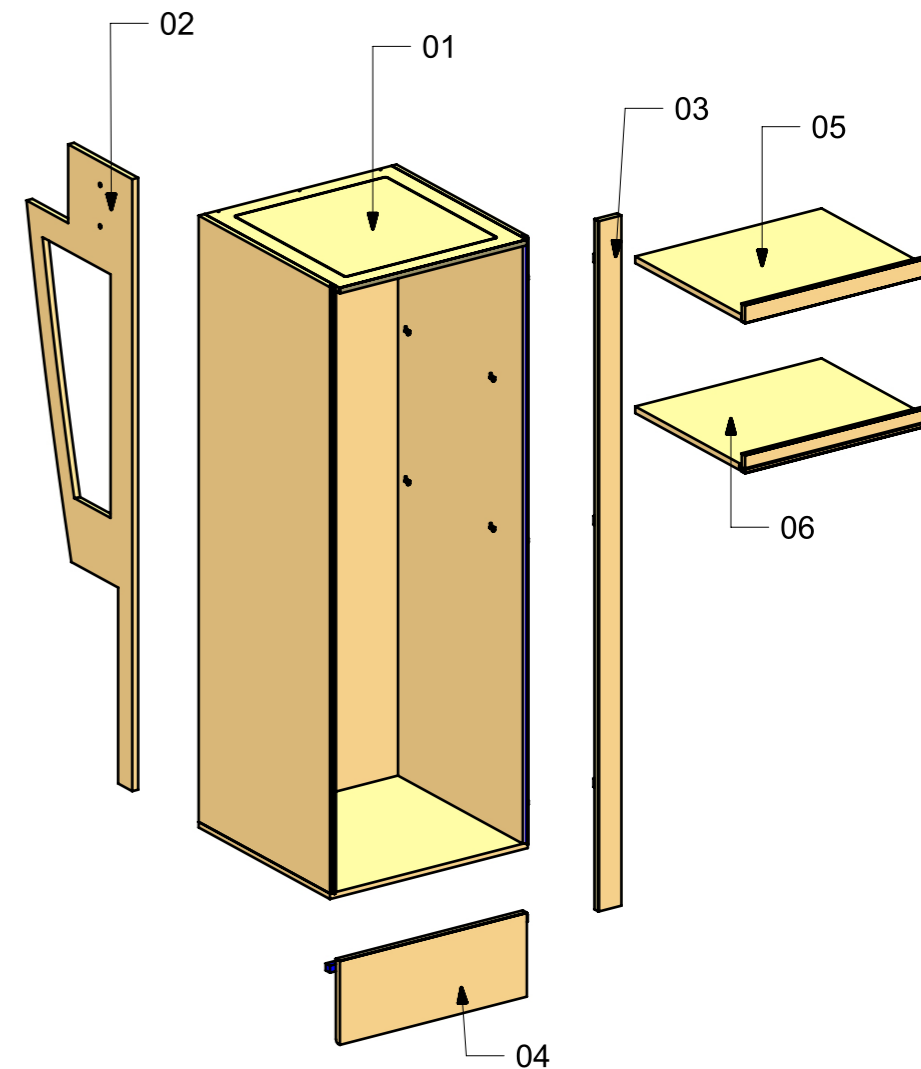

FERRAMENTA	QTY
REGGRIPIANO 1PERNO 1FORO_FBC_00257770	8
KEKU ESTRAZIONE FRONTALE PARTE TELAIO AS_HAFELE_262_50_368	3
BUSSOLA 6MA X 10 FORO DIAM.8	2
KEKU ESTRAZIONE FRONTALE PARTE PANNELLO AS_HAFELE_262_50_359	3

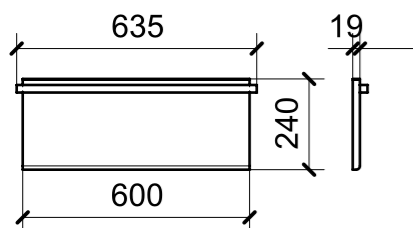

04

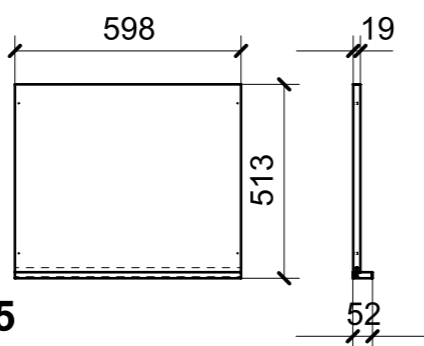

05

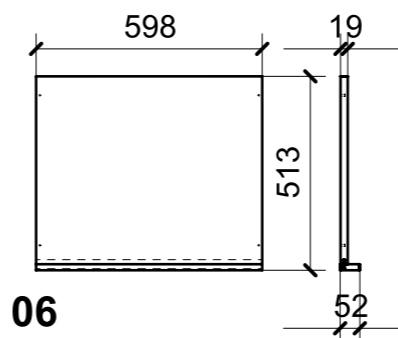

06

LOCALE	CODICE	DESCRIZIONE COMPONENTE	FINITURA	Q.TA
CABINA MARINAIO	MD299_MG_MK01	BASE LAVELLO	LAMINATO CLEAF SABLE' S166	1

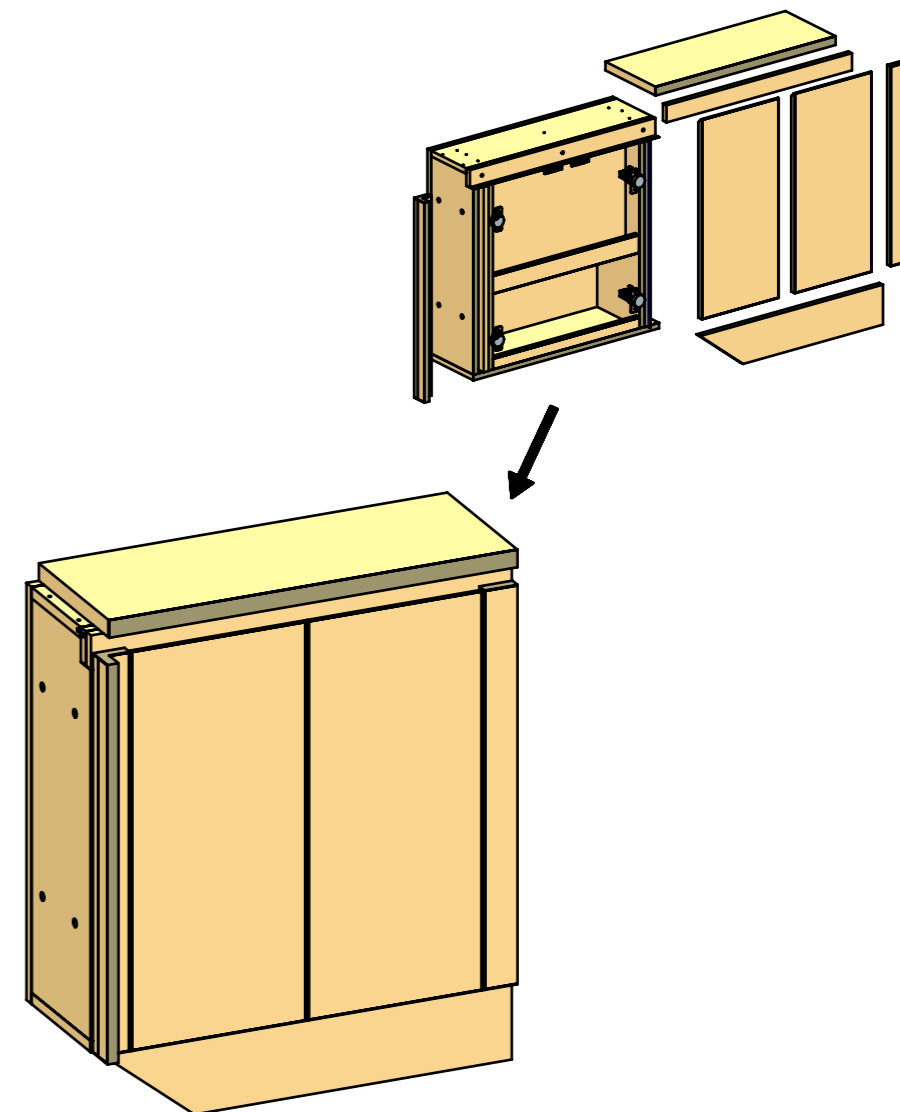
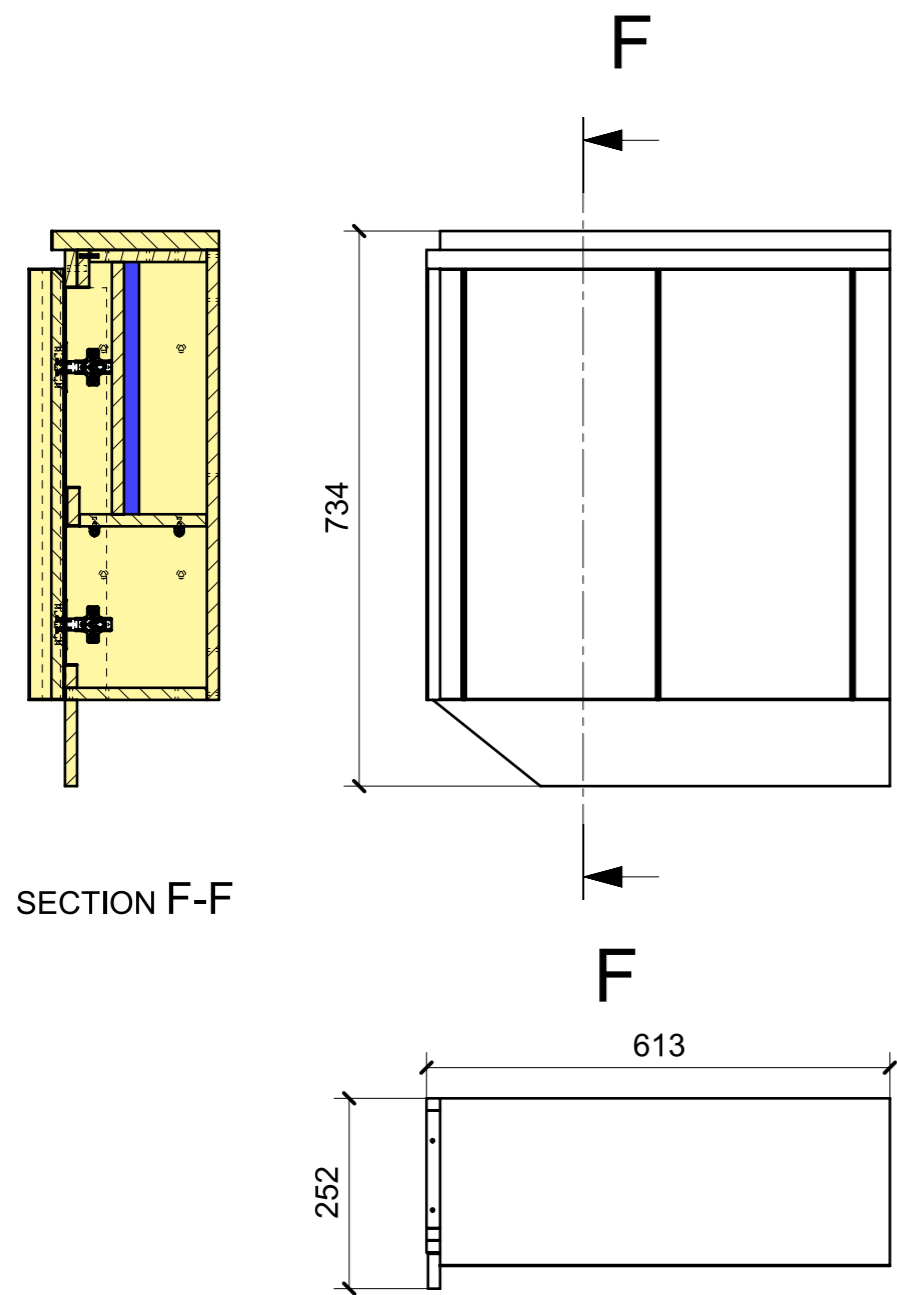

FERRAMENTA	QTY
BASE_6_HAFELE_329_84_026	4
BUSSOLA 5MA ANKOR BORGHI X CERNIERA PIANA	16
BUSSOLA 6MA X 10 FORO DIAM.8	4
CERNIERA 94° PIANA AMMORTIZZATA_HAFELE_329_49_310	4
CHIUSURA A SPINTA_TECHNOPARTNER_SOU C3-203	2
REGGRIPIANO 1PERNO 1FORO_FBC_00257770	4
VITE 4MAX8 ANKOR BORGHI X CERNIERA PIANA	16

LOCALE	CODICE	DESCRIZIONE COMPONENTE	FINITURA	Q.TA
CABINA MARINAIO	MD299_MK01	BASE LAVELLO	LAMINATO CLEAF SABLE' S166	1

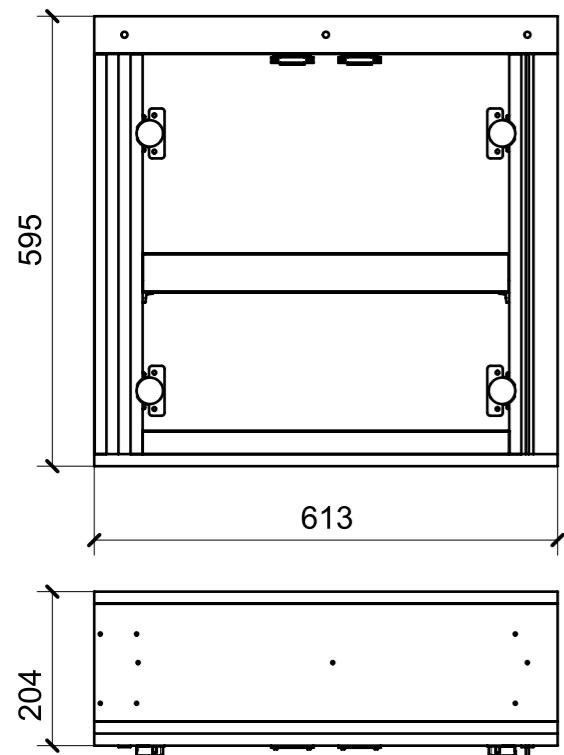

01

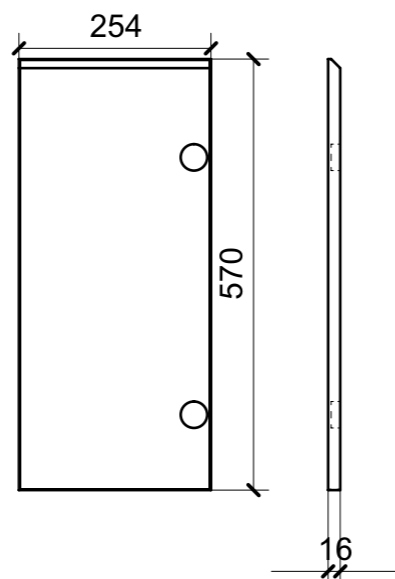

03

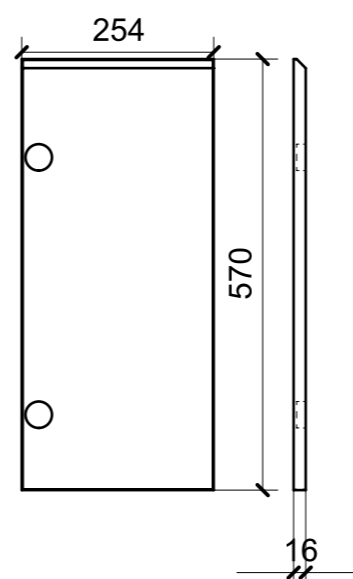

04

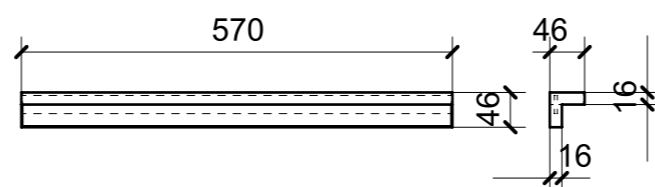

02

ELEMENTI DA MONTARE IN MG_MK01
e spedire con unico imballo

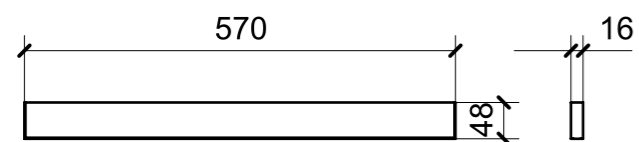
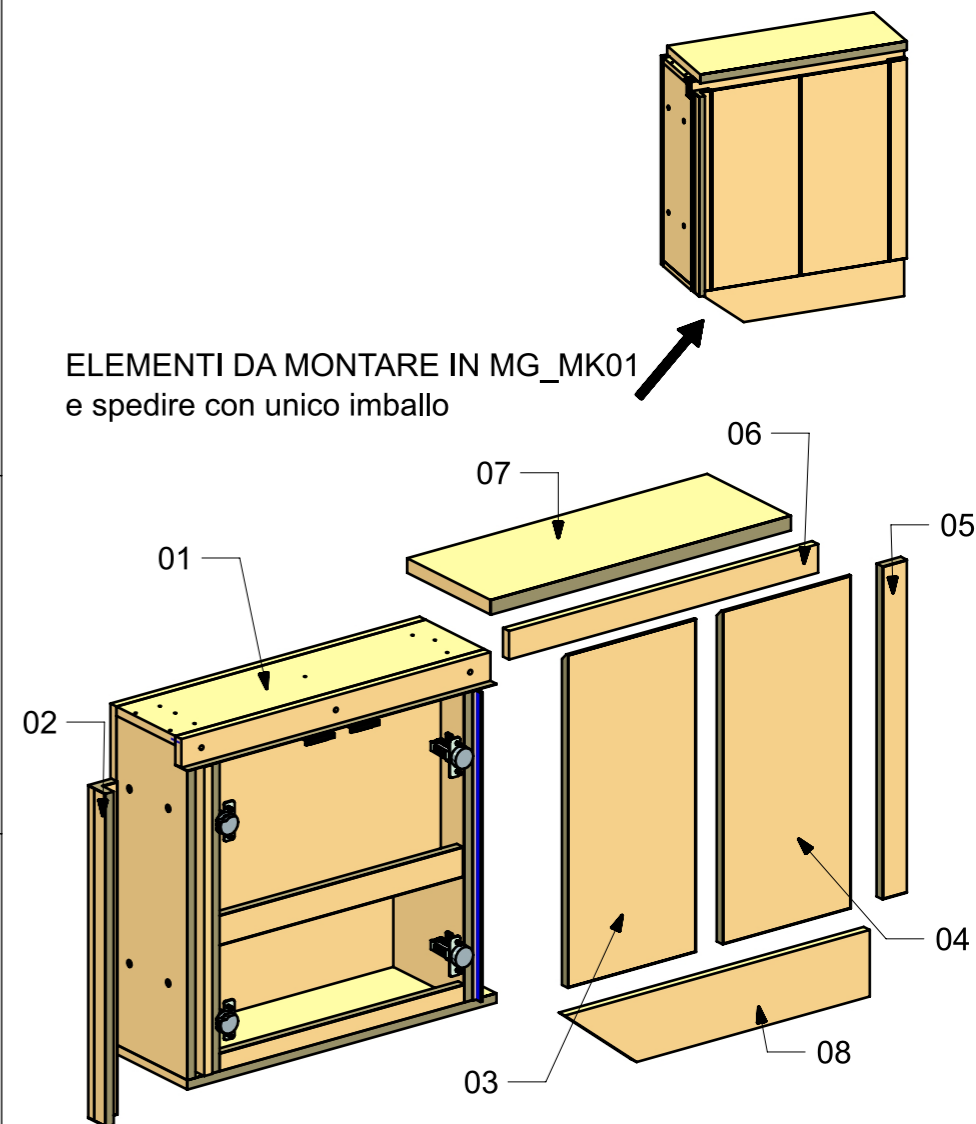

05

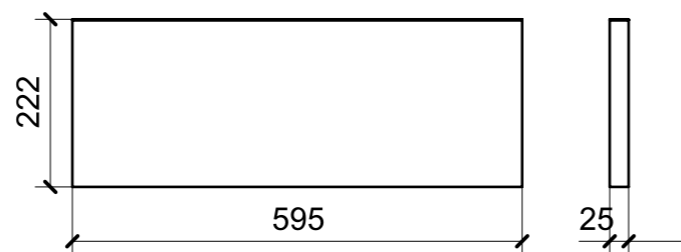

07

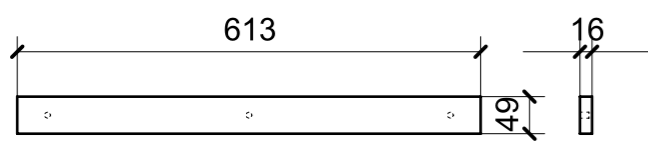

06

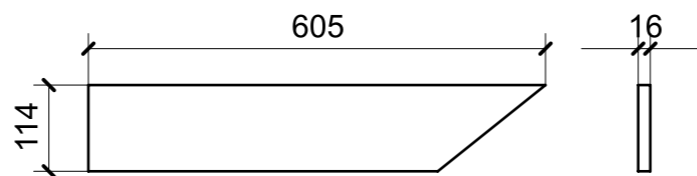

08

FERRAMENTA	QTY
CHIUSURA A SPINTA_TECHNOPARTNER_SOU C3-203	2
BASE_6_HAFELE_329_84_026	4
REGGRIPIANO 1PERNO 1FORO_FBC_00257770	4
BUSSOLA 6MA X 10 FORO DIAM.8	4
BUSSOLA 5MA ANKOR BORGHI X CERNIERA PIANA	16
CERNIERA 94° PIANA AMMORTIZZATA_HAFELE_329_49_310	4
VITE 4MAX8 ANKOR BORGHI X CERNIERA PIANA	16

LOCALE	CODICE	DESCRIZIONE COMPONENTE	FINITURA	Q.TA
CABINA MARINAIO	MD299_MO01	RIVESTIMENTO PARETE LETTO PRUA	LAMINATO CLEAF SABLE' S166/OKUME' GREZZO	1

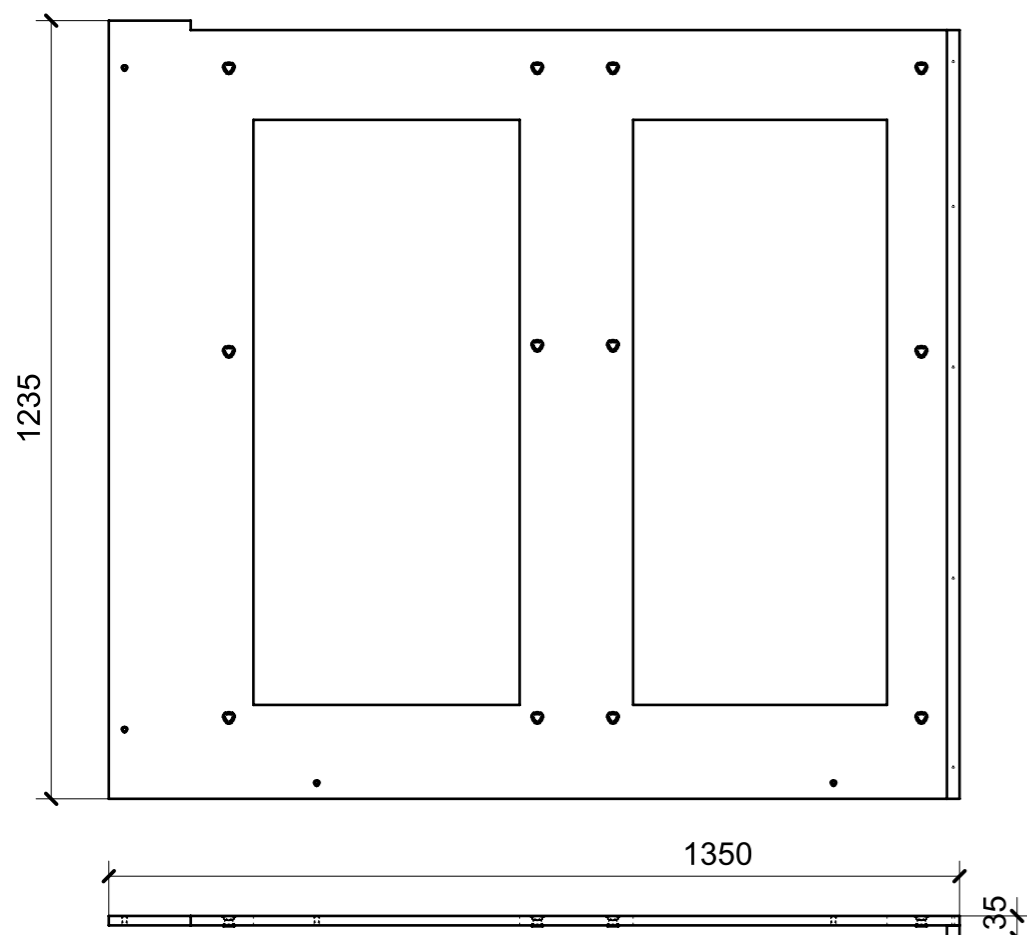

FERRAMENTA	QTY
BUSSOLA 6MA X 10 FORO DIAM.8	4
FM INCASSO_ITALVIPLA_973_FMPC_F1A	12

01

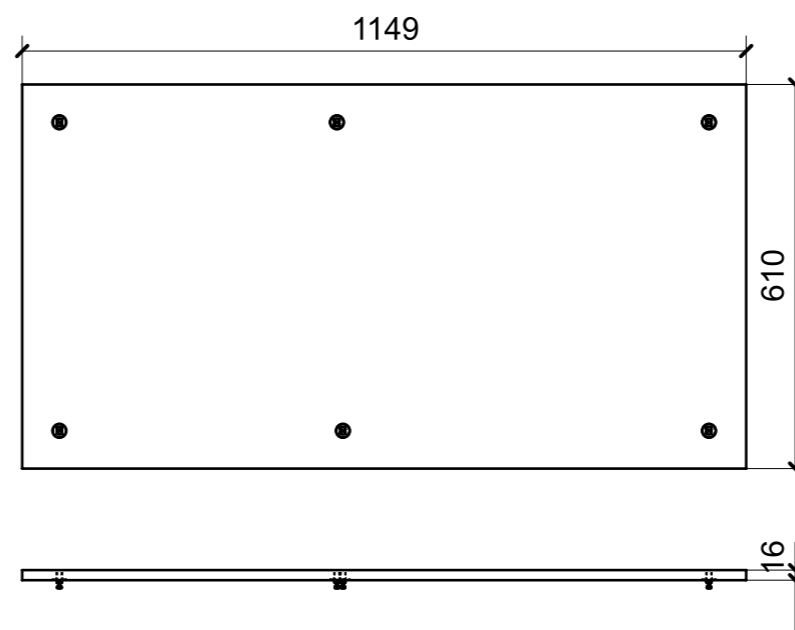

FERRAMENTA	QTY
MS INCASSO_ITALVIPLA_972_FMPC_M1B	6

02

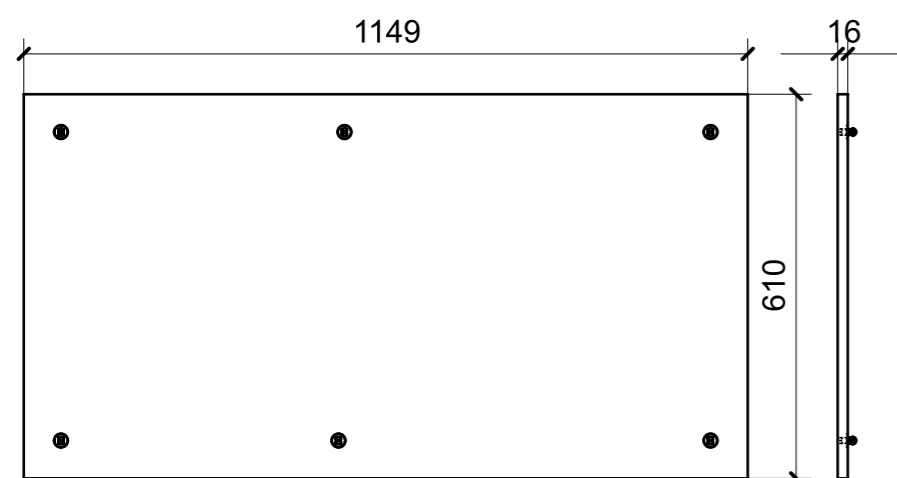

FERRAMENTA	QTY
MS INCASSO_ITALVIPLA_972_FMPC_M1B	6

03

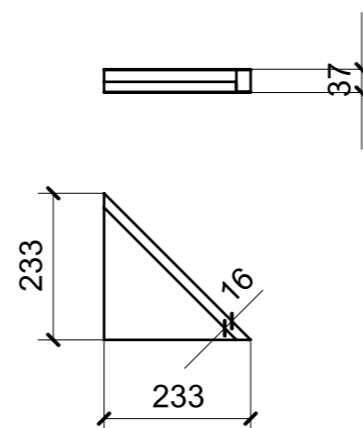

04

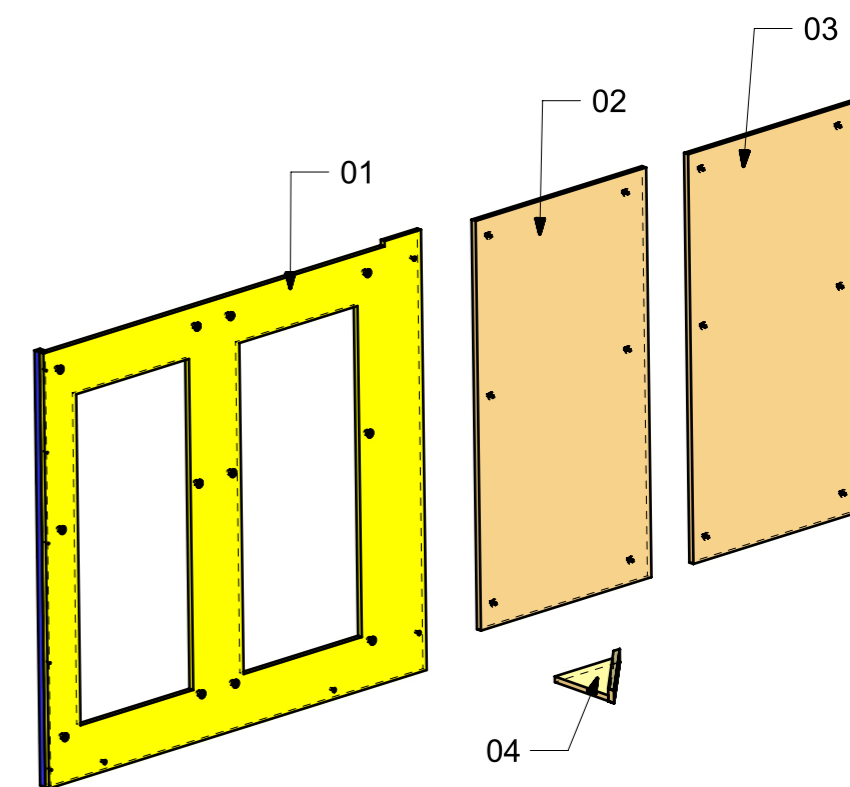

FERRAMENTA	QTY
BUSSOLA 6MA X 10 FORO DIAM.8	4
FM INCASSO_ITALVIPLA_973_FMPC_F1A	12
MS INCASSO_ITALVIPLA_972_FMPC_M1B	12

LOCALE	CODICE	DESCRIZIONE COMPONENTE	FINITURA	Q.TA
CABINA MARINAIO	MD299_MP01	PIELETTO PRUA	LAMINATO CLEAF SABLE' S166	1

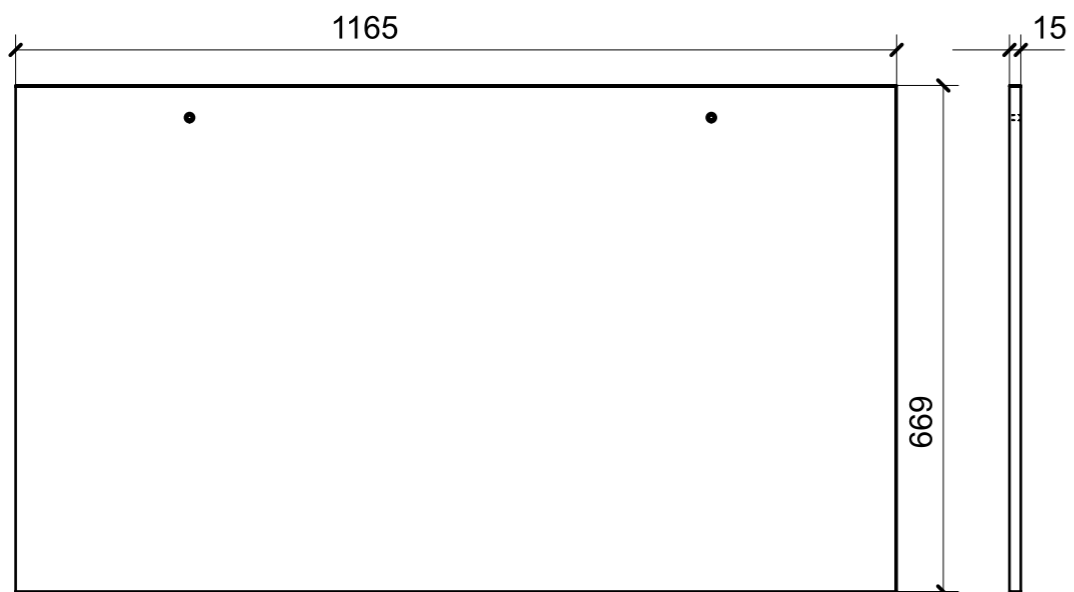

01

FERRAMENTA	QTY
BUSSOLA 6MA X 10 FORO DIAM.8	2

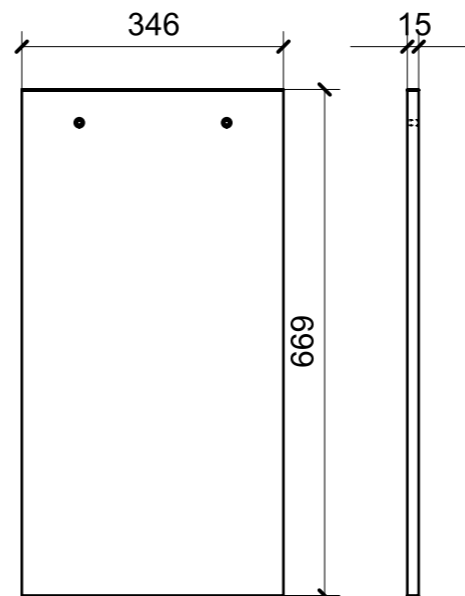

02

FERRAMENTA	QTY
BUSSOLA 6MA X 10 FORO DIAM.8	2

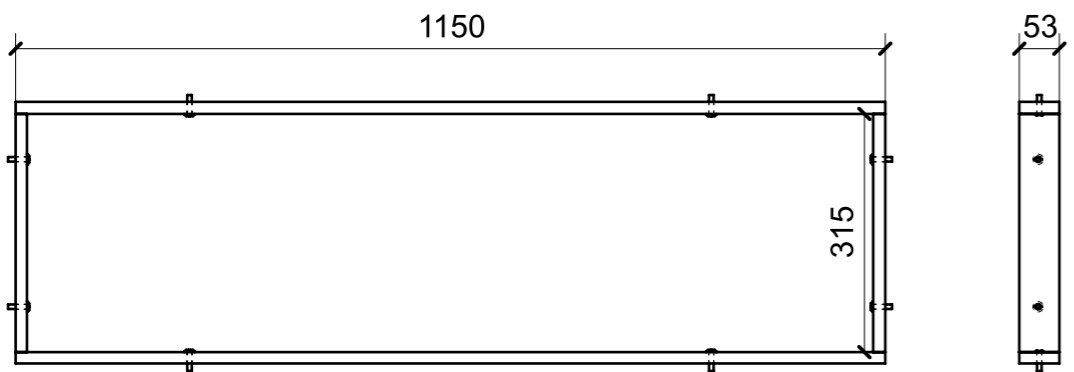

03

FERRAMENTA	QTY
VITE 6MA X 25 TESTA BOMBATA	8

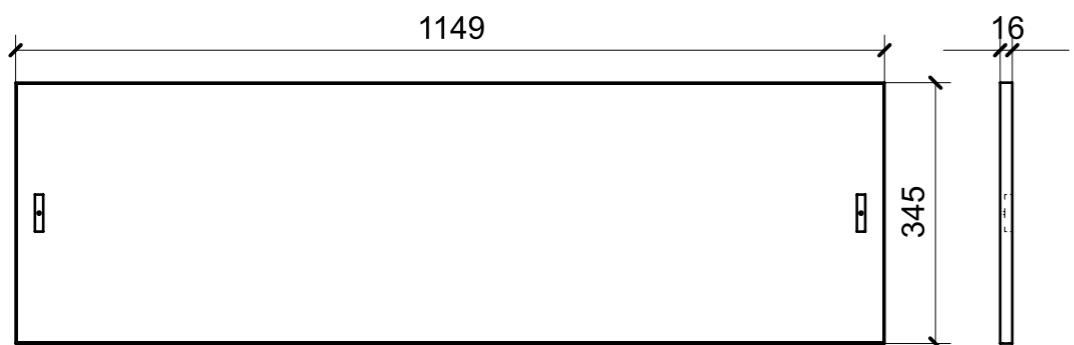

04

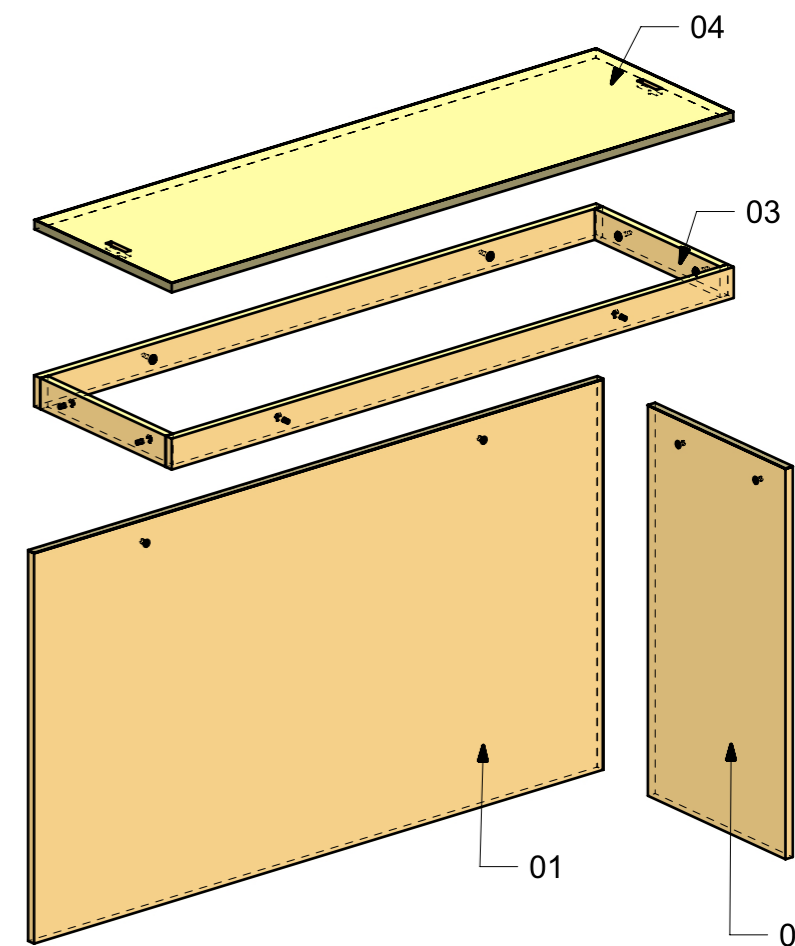

FERRAMENTA	QTY
BUSSOLA 6MA X 10 FORO DIAM.8	4
VITE 6MA X 25 TESTA BOMBATA	8

LOCALE	CODICE	DESCRIZIONE COMPONENTE	FINITURA	Q.TA
CABINA MARINAIO	MD299_MQ01	BASE QUADRO ELETTRICO	LAMINATO CLEAF SABLE' S166/OKUME' GREZZO	1

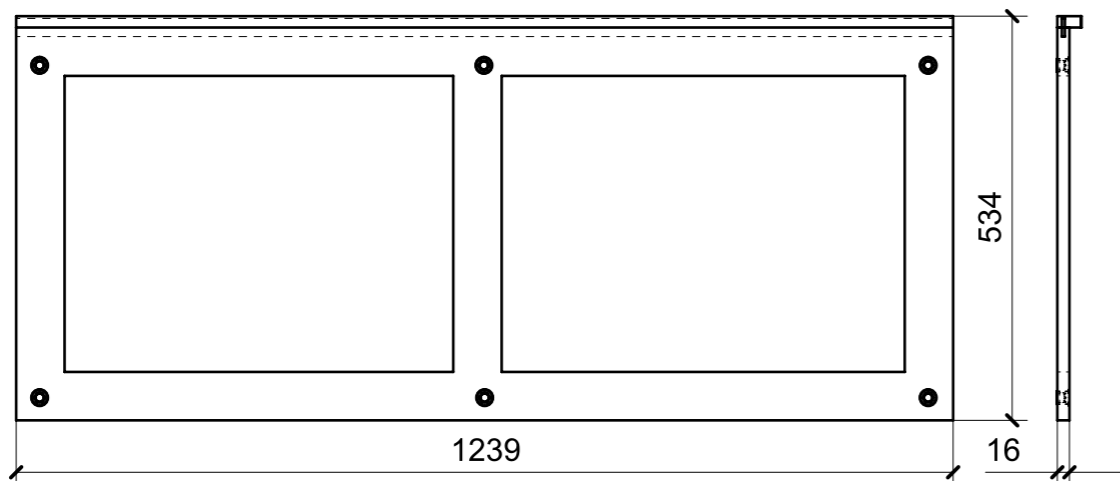

02

FERRAMENTA	QTY
FM INCASSO_ITALVIPLA_973_FMPC_F1A	6

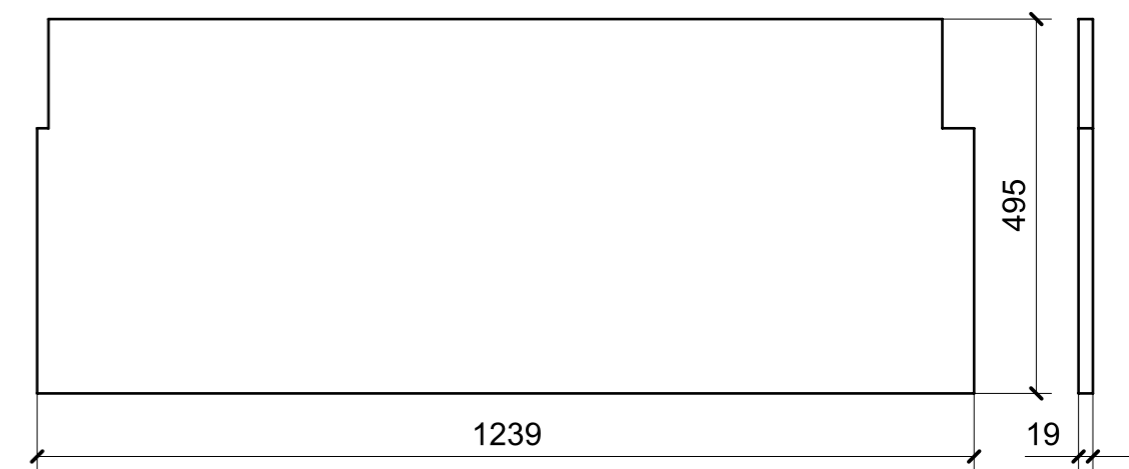

01

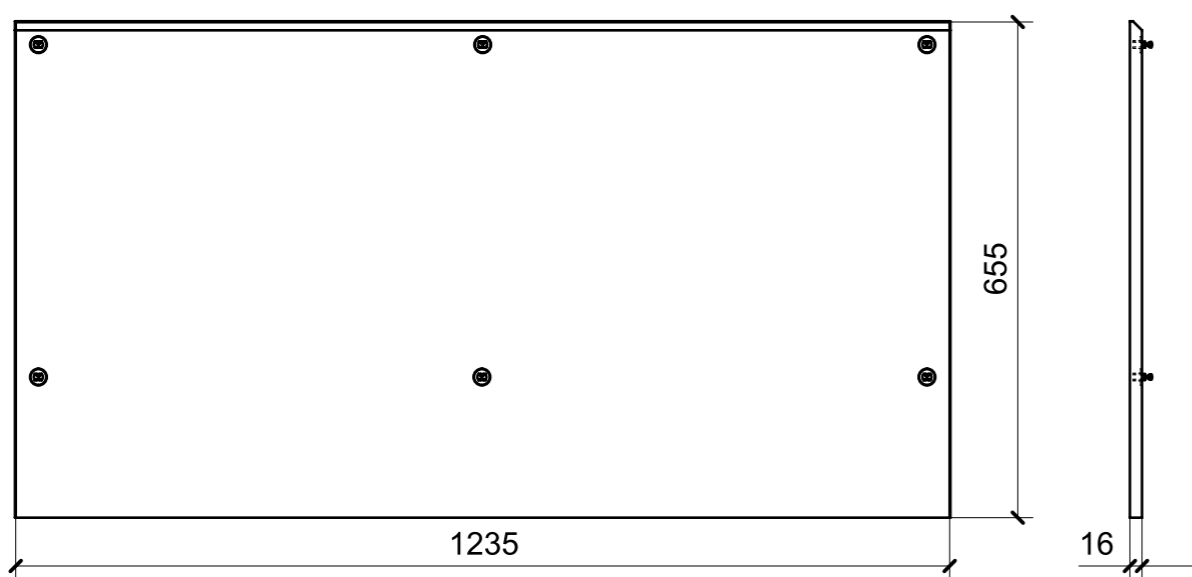

03

FERRAMENTA	QTY
MS INCASSO_ITALVIPLA_972_FMPC_M1B	6

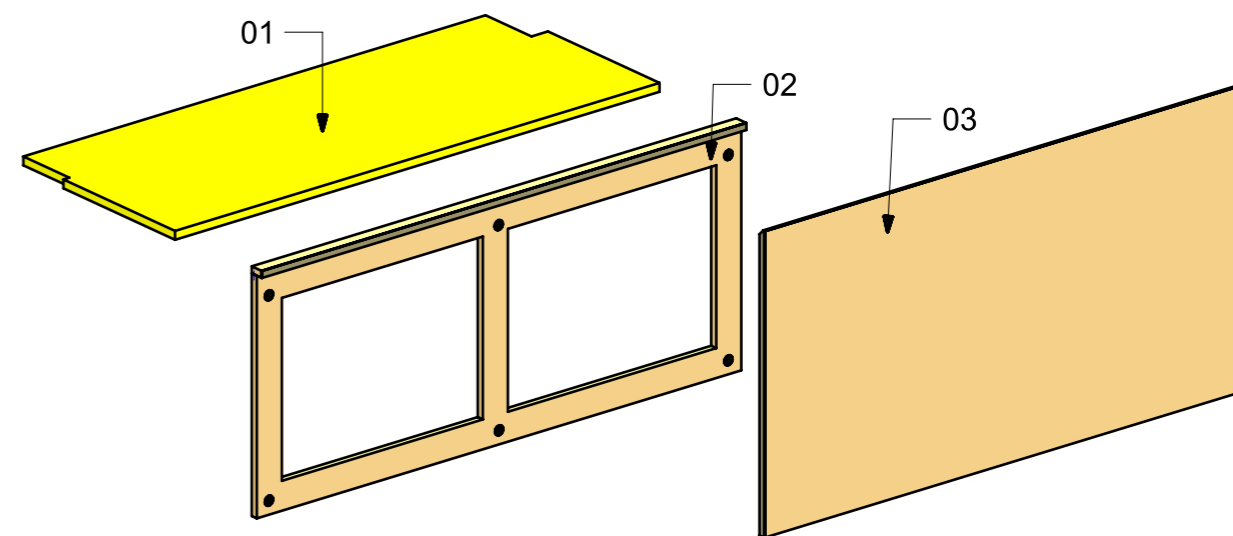

FERRAMENTA	QTY
FM INCASSO_ITALVIPLA_973_FMPC_F1A	6
MS INCASSO_ITALVIPLA_972_FMPC_M1B	6

LOCALE	CODICE	DESCRIZIONE COMPONENTE	FINITURA	Q.TA
CABINA MARINAIO	MD299_MG_MX01	PENSILE BAGNO	LAMINATO CLEAF SABLE' S166	1

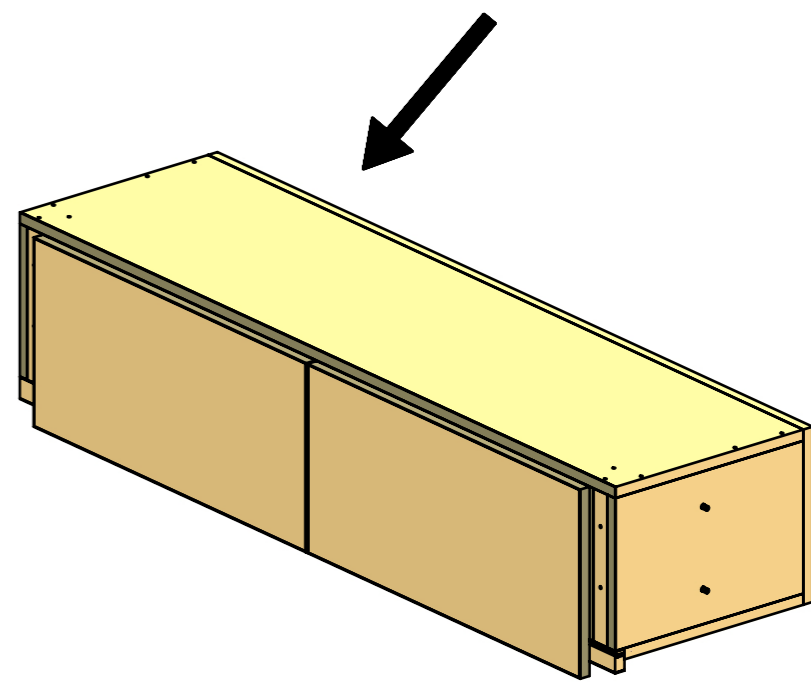
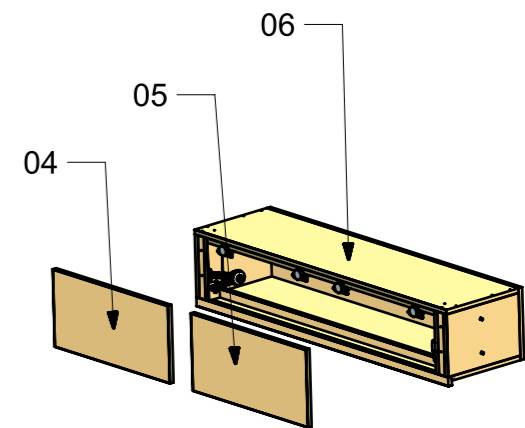
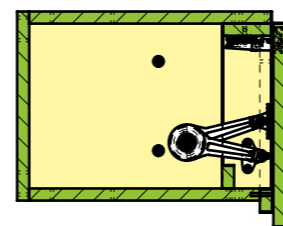
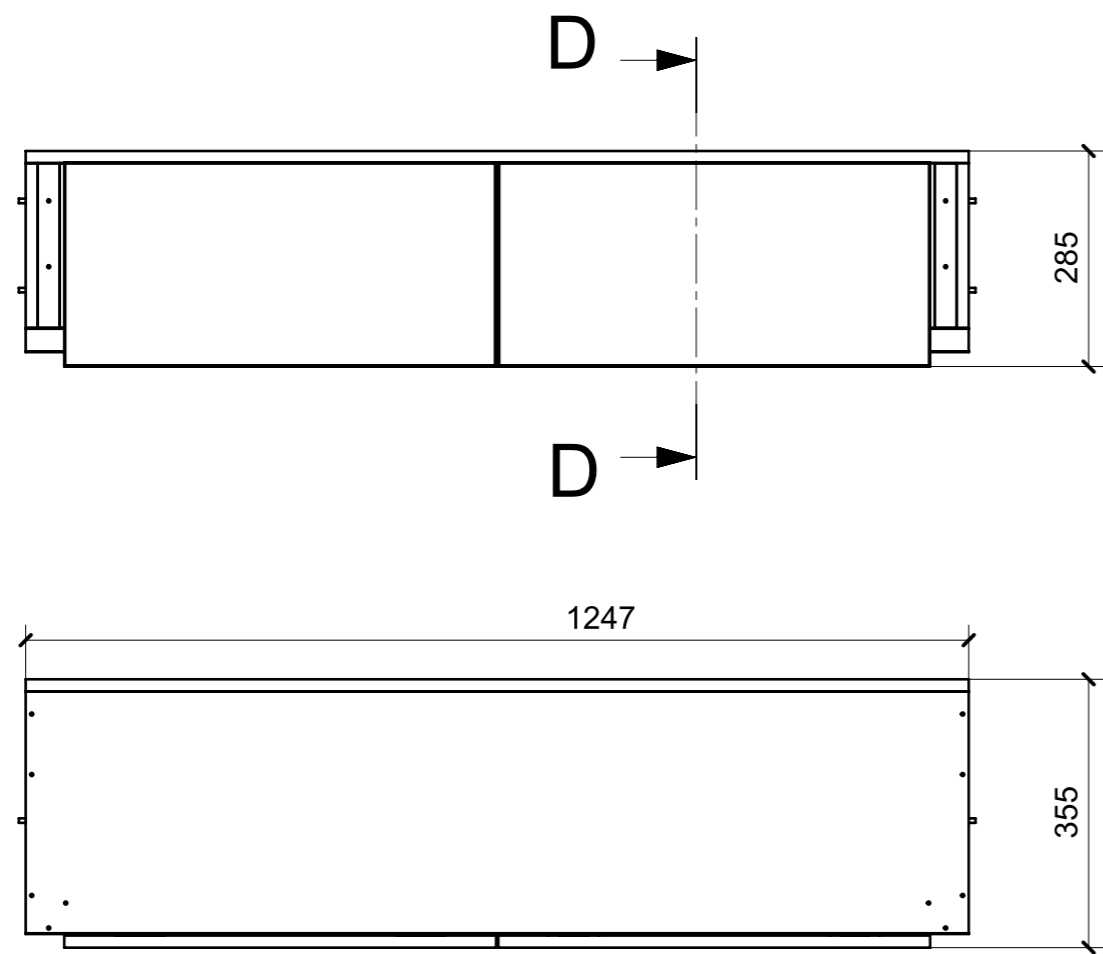

LOCALE	CODICE	DESCRIZIONE COMPONENTE	FINITURA	Q.TA
CABINA MARINAIO	MD299_MX01	PENSILE BAGNO	LAMINATO CLEAF SABLE' S166	1

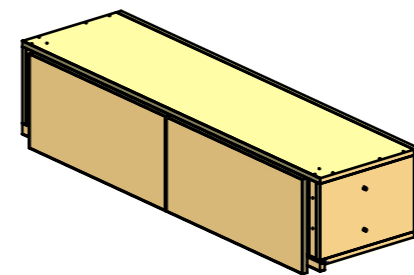
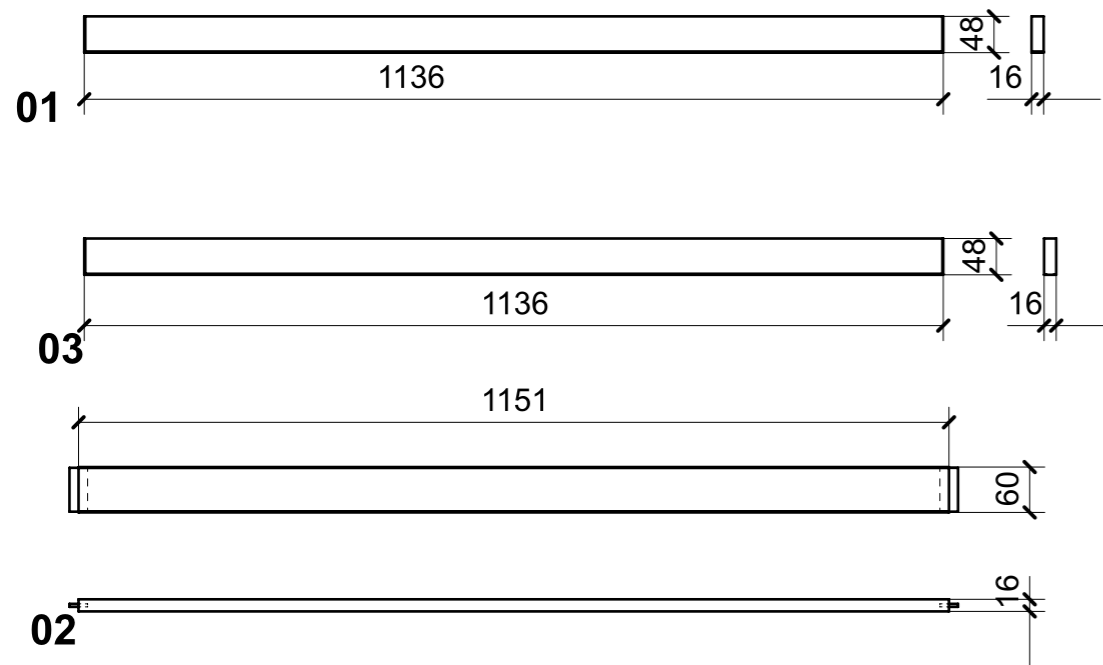

ELEMENTI DA MONTARE IN MG_MX01
e spedire con unico imballo

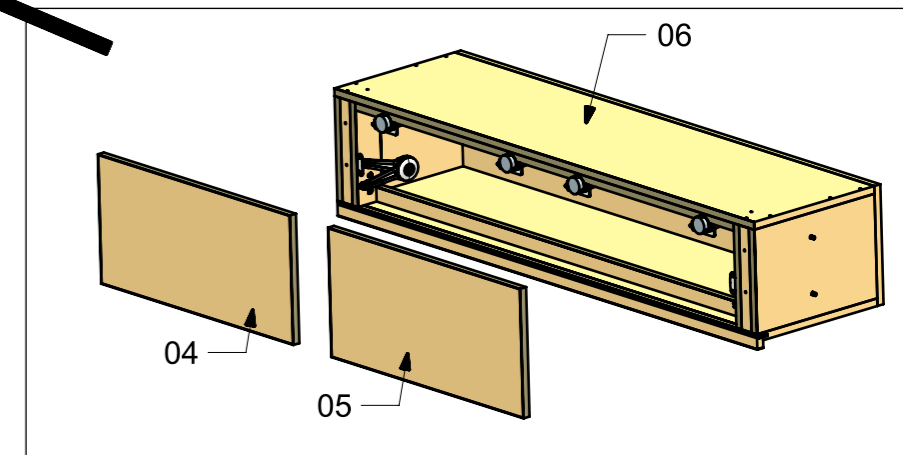

ELEMENTI DA MONTARE IN MG_MX01
e spedire con unico imballo

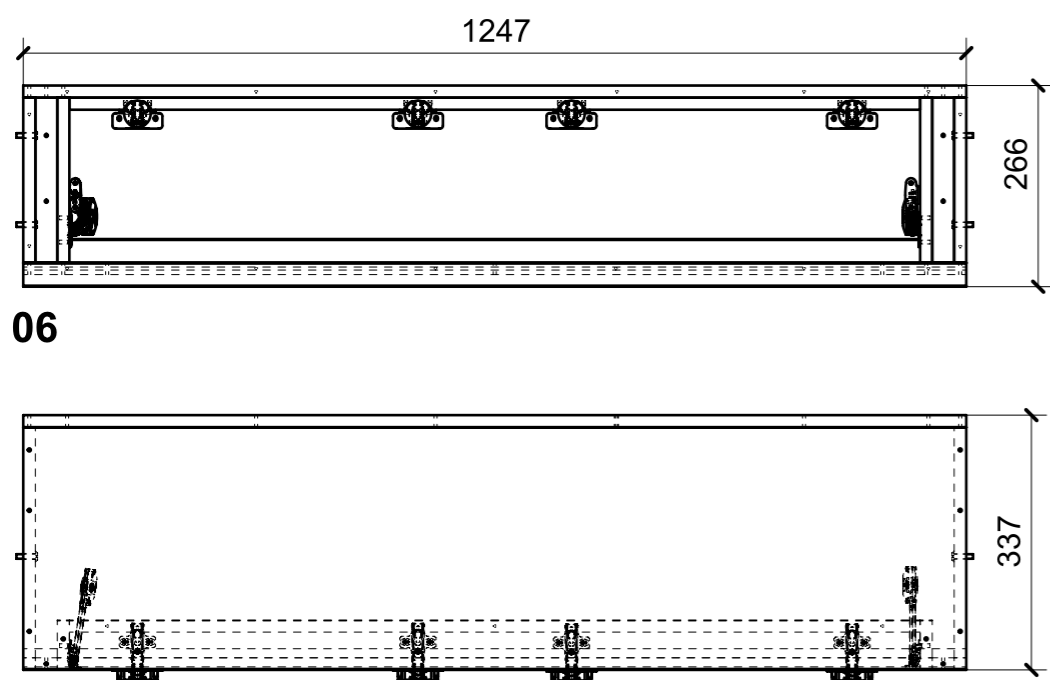

06

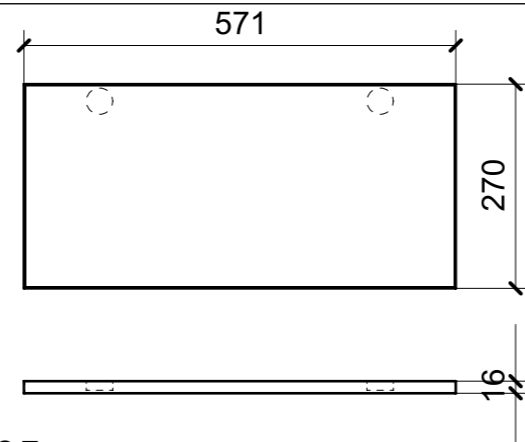

05

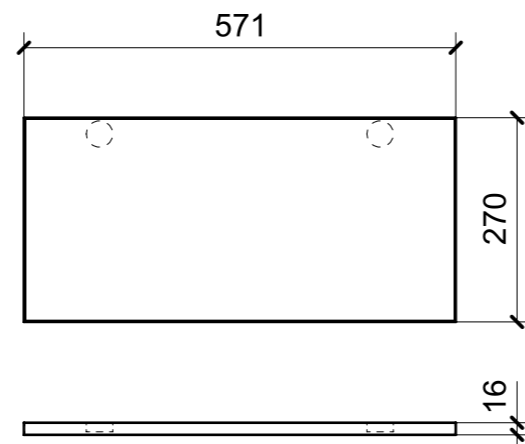

04

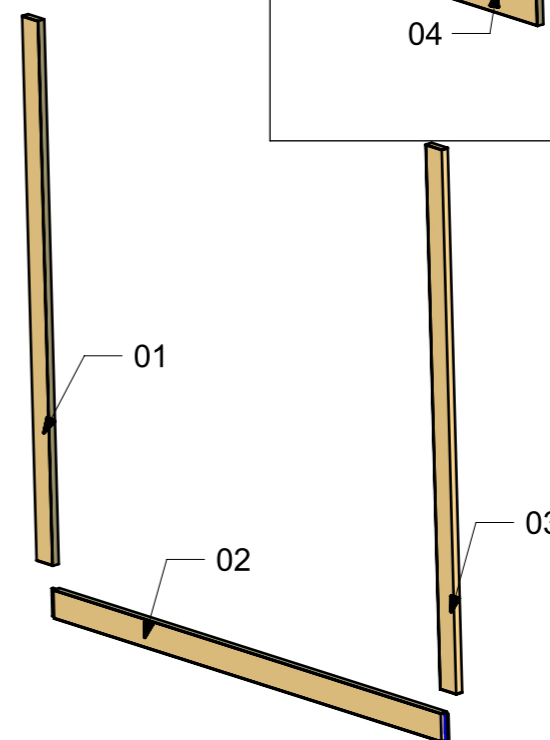

FERRAMENTA	QTY
BASE_3_HAFELE_329_84_023	4
BRACCETTO PER ANTA_HAFELE_373_66_611	1
BRACCETTO PER ANTA_HAFELE_373_66_611MIRROR_	1
BUSSOLA 5MA ANKOR BORGHI	8
BUSSOLA 5MA ANKOR BORGHI X CERNIERA PIANA	8
CERNIERA 94° PIANA AMMORTIZZATA_HAFELE_329_49_310	4
VITE 4MAX8 ANKOR BORGHI	8
VITE 4MAX8 ANKOR BORGHI X CERNIERA PIANA	8
VITE 6MA X 25 TESTA BOMBATA	4

LOCALE	CODICE	DESCRIZIONE COMPONENTE	FINITURA	Q.TA
CABINA MARINAIO	MD299_MG_MY01	MURATA BASSA SX BAGNO	LAMINATO CLEAF SABLE' S166/GREZZO	1

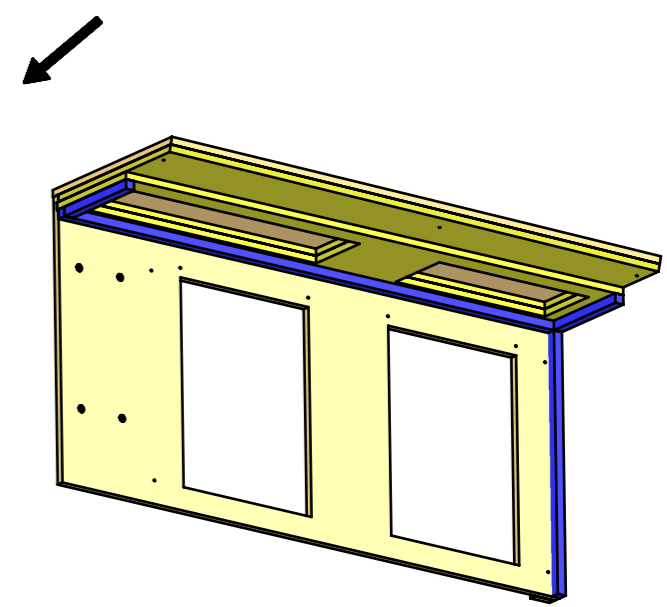
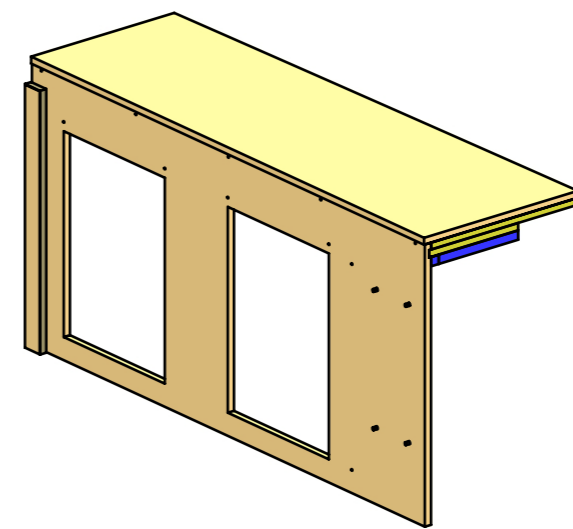
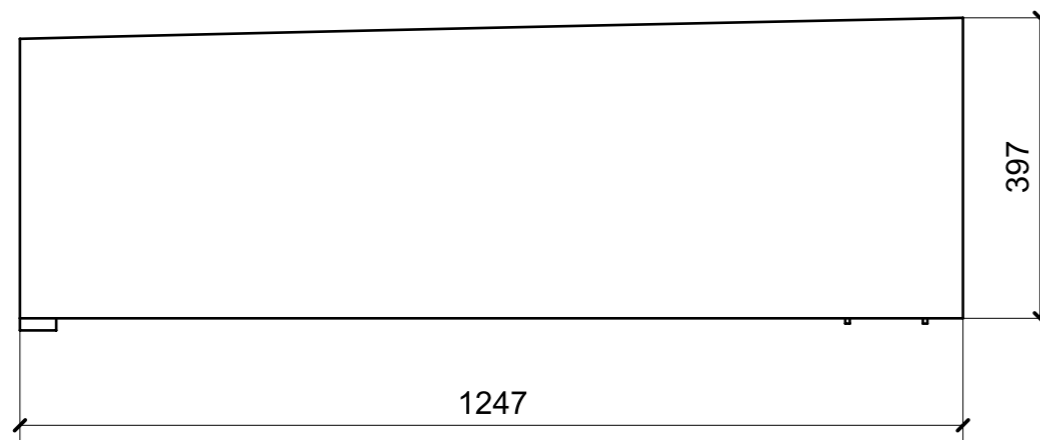
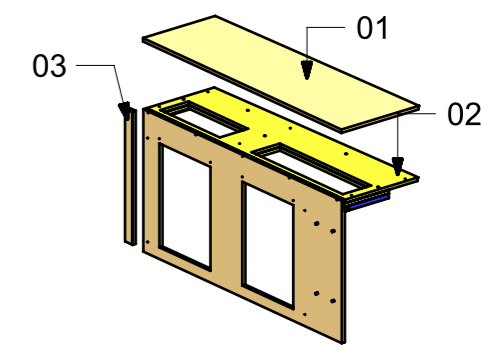
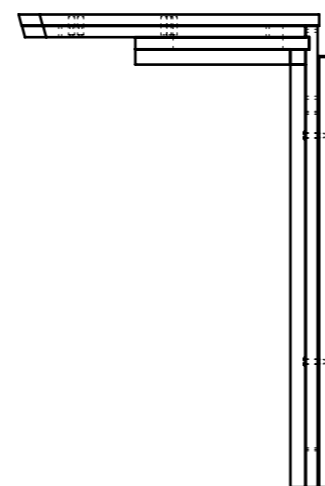
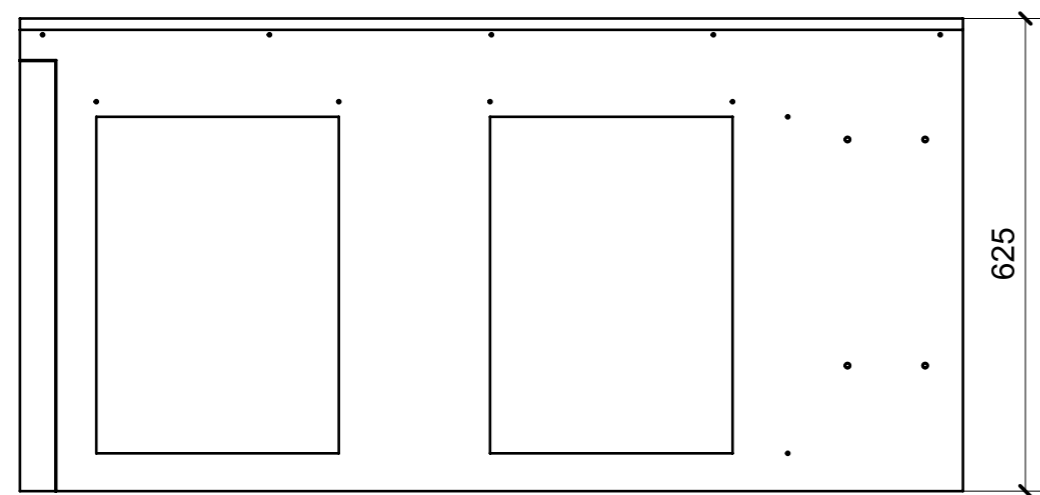

FERRAMENTA	QTY
VITE 6MA X 25 TESTA BOMBATA	4

LOCALE	CODICE	DESCRIZIONE COMPONENTE	FINITURA	Q.TA
CABINA MARINAIO	MD299_MY01	MURATA BASSA SX BAGNO	LAMINATO CLEAF SABLE' S166/GREZZO	1

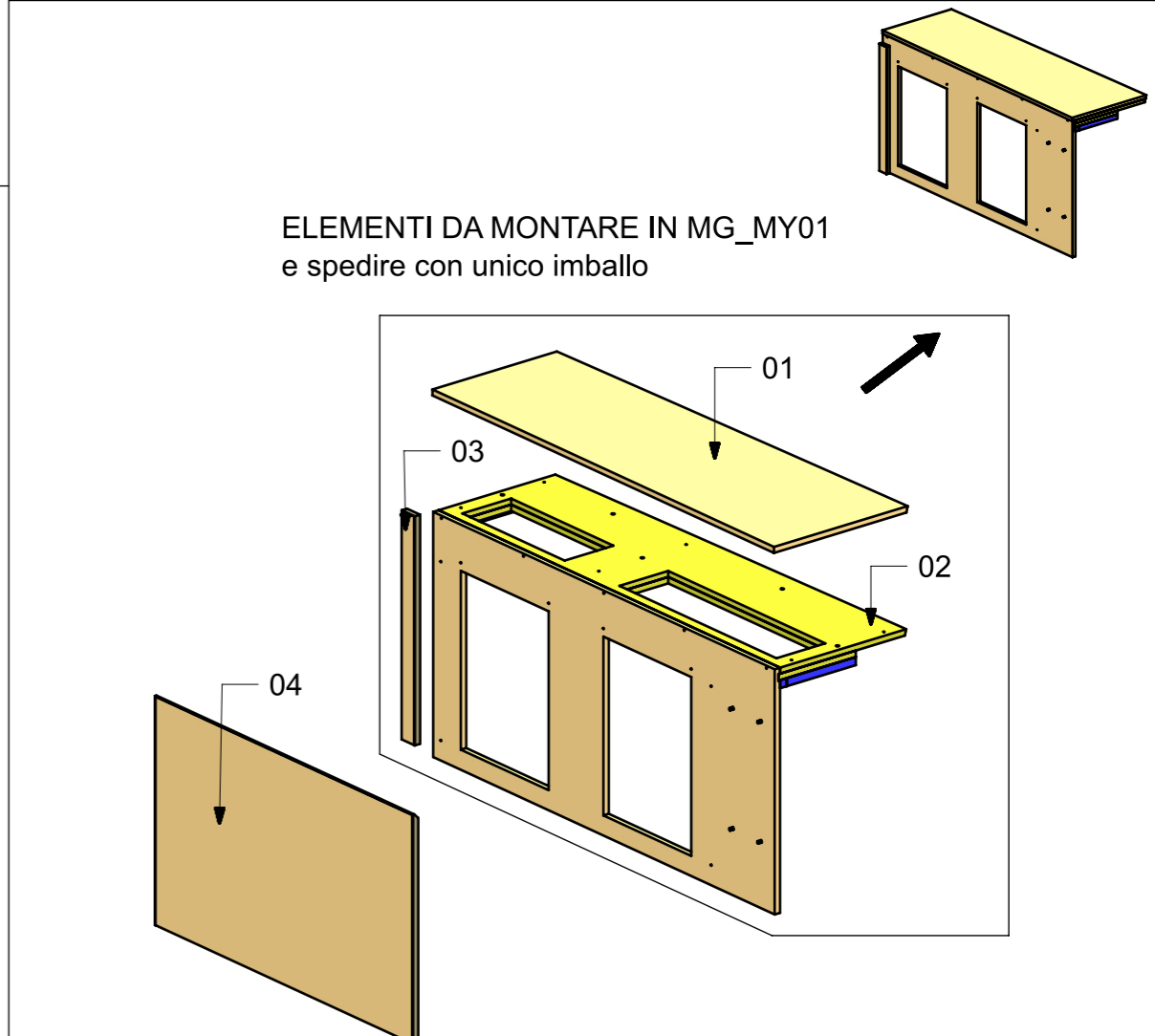
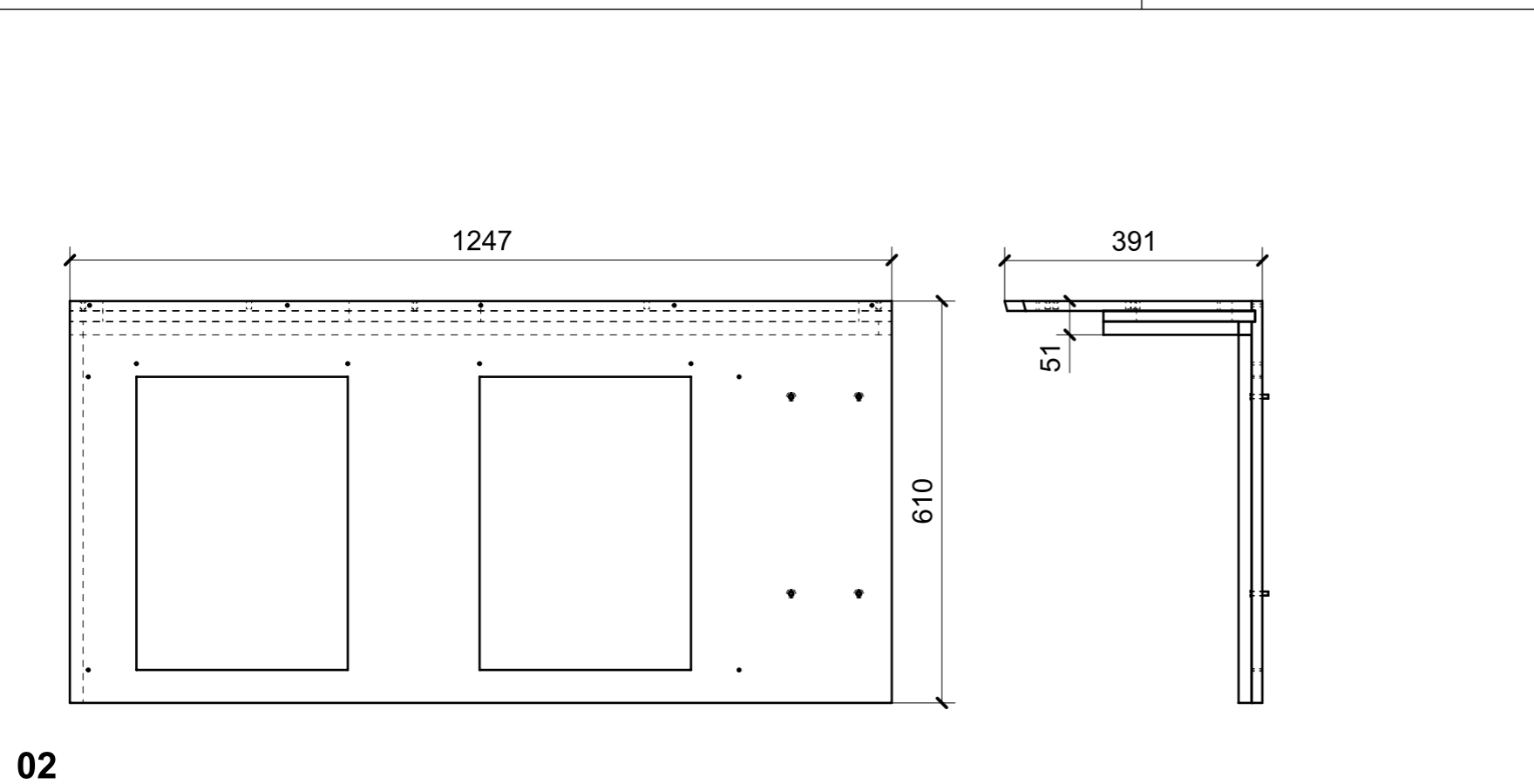
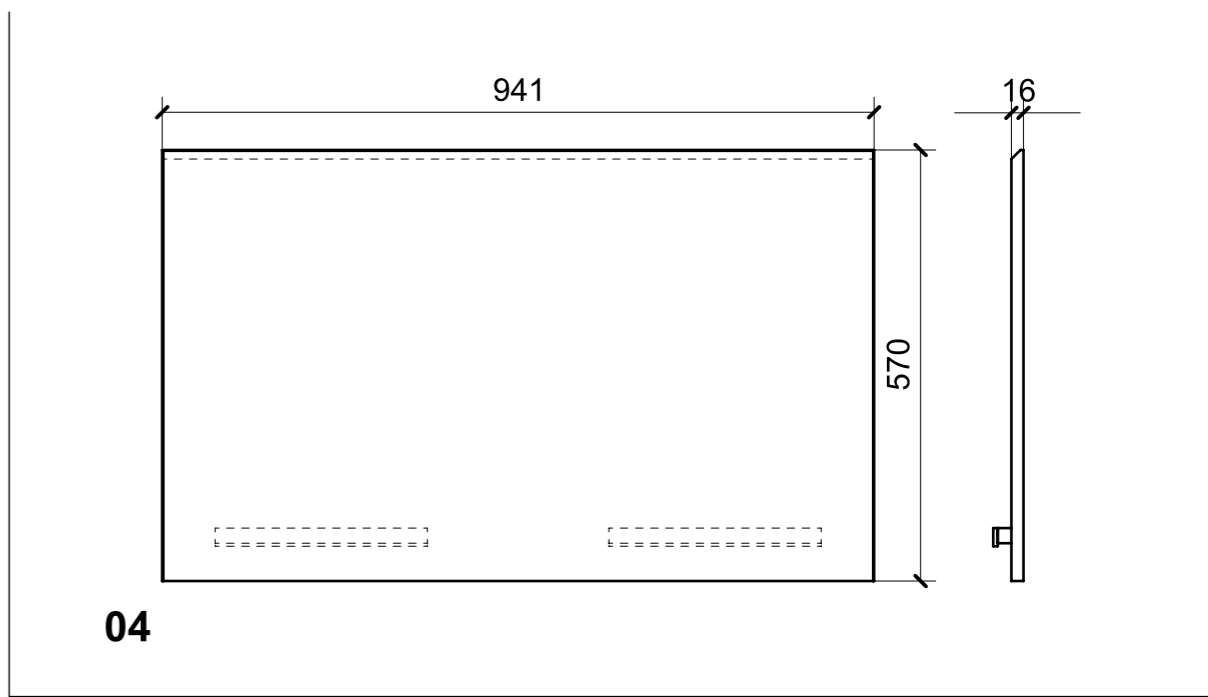
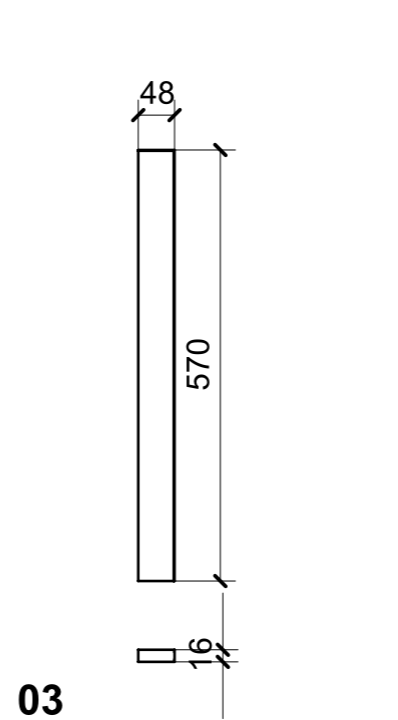
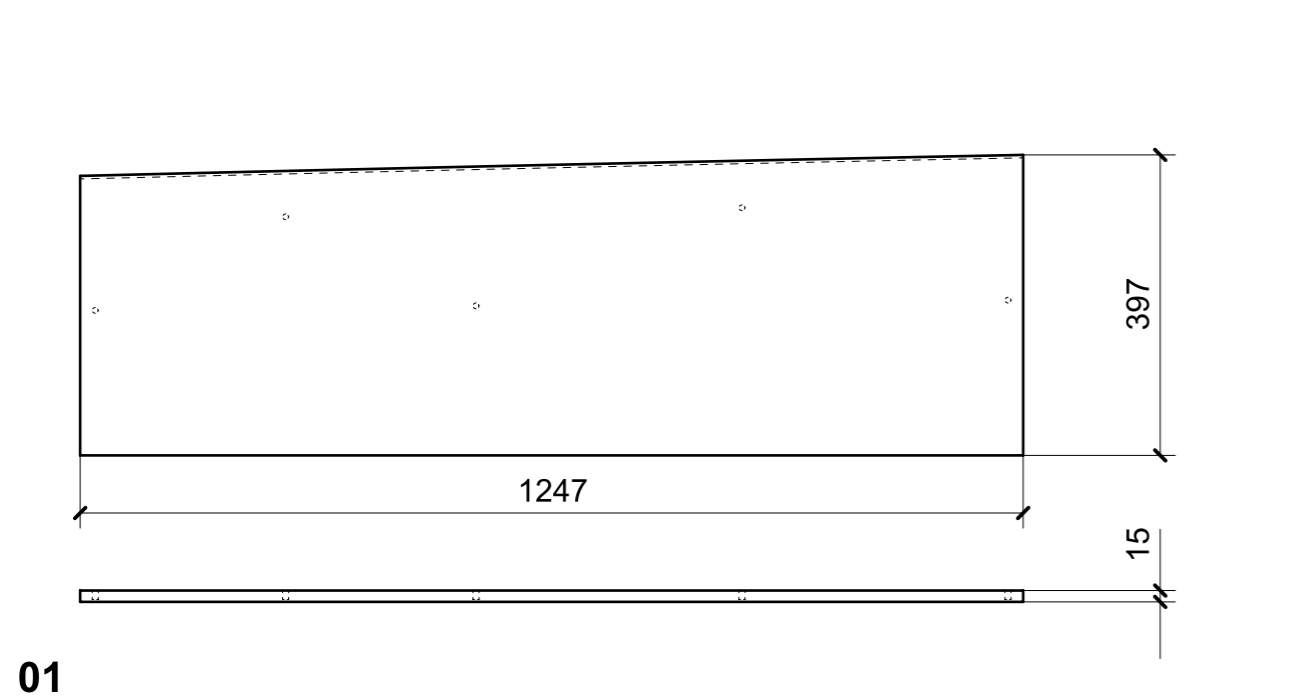

FERRAMENTA	QTY
VITE 6MA X 25 TESTA BOMBATA	4