

LOCALE	CODICE	DESCRIZIONE COMPONENTE	FINITURA	Q.TA
CABINA ARMATORE	MD299_MF01_AV01	ANTE MOBILE MURATA_STD VAR 1 AZZURRO\GRIGIO 100 GLOSS		1

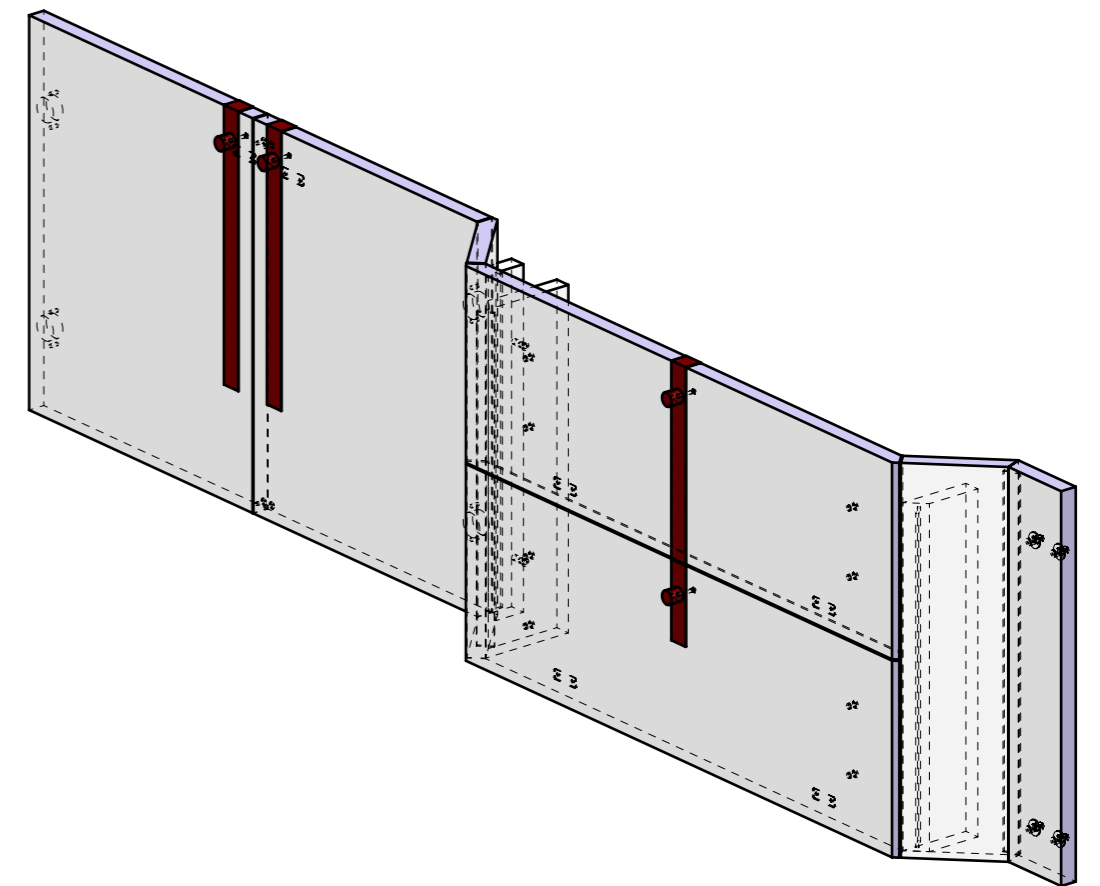

FERRAMENTA	QTY
BUSSOLA 5MA X 10 FORO DIAM.8	8
BUSSOLA 6MA X 10 FORO DIAM.8	2
GOMMINO PARACOLPO ANTA	4
MS INCASSO_ITALVIPLA_972_FMPC_M1B	4
PLACCHETTA COUNTER STEEL_TECHNOPARTNER_MC-JM49	6
VITE 4MA X 30 TESTA SVASATA ESAGONALE NERA	8

LOCALE	CODICE	DESCRIZIONE COMPONENTE	FINITURA	Q.TA
CABINA ARMATORE	MD299_L01_AV01	ANTE MOBILE MURATA_STD VAR 1 AZZURRO\GRIGIO 100 GLOSS	LACCATO AZZURRO\GRIGIO NCS S 3005 B 80 G 100 gloss	1

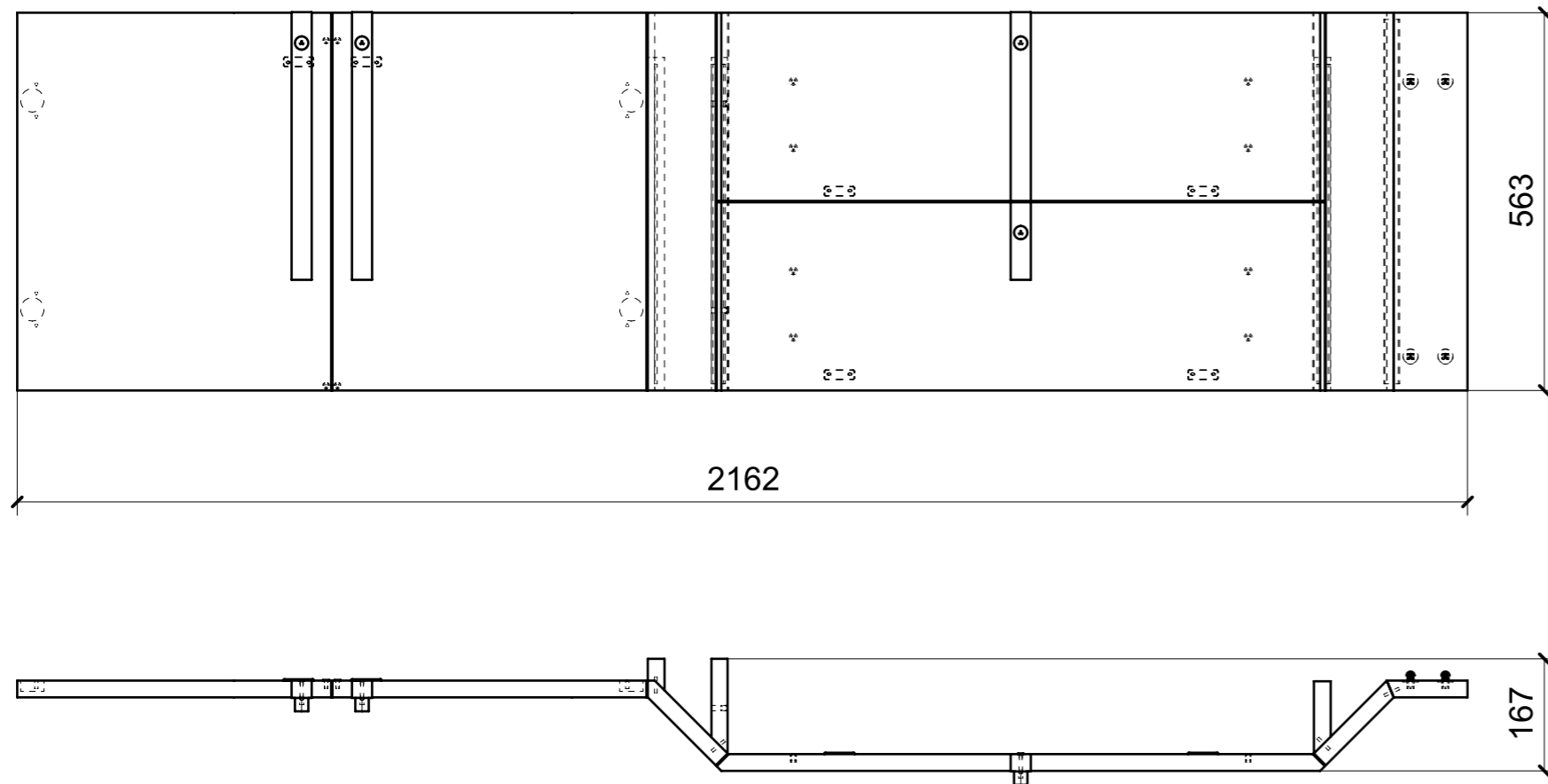
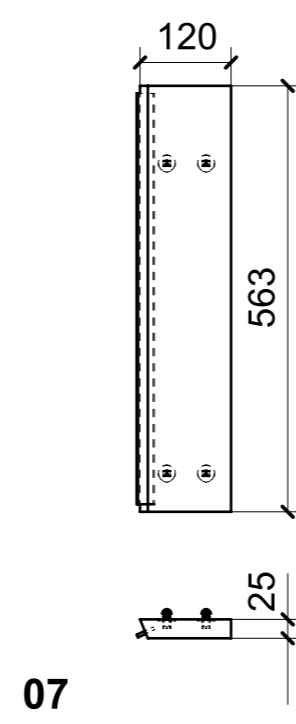
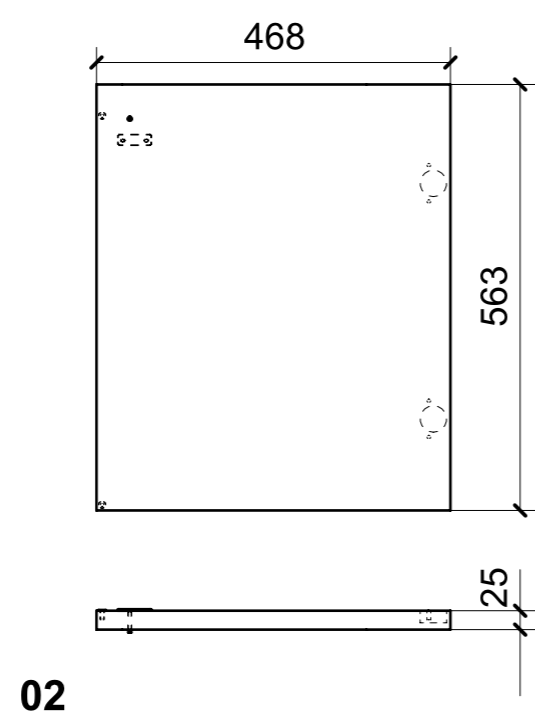
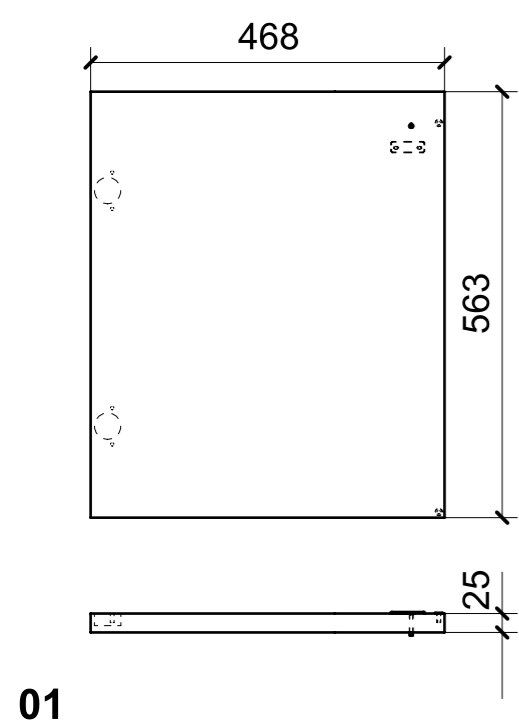

ELEMENTI DA MONTARE CON A10/A11/A12/A22 IN MF_AV01
e spedire con unico imballo

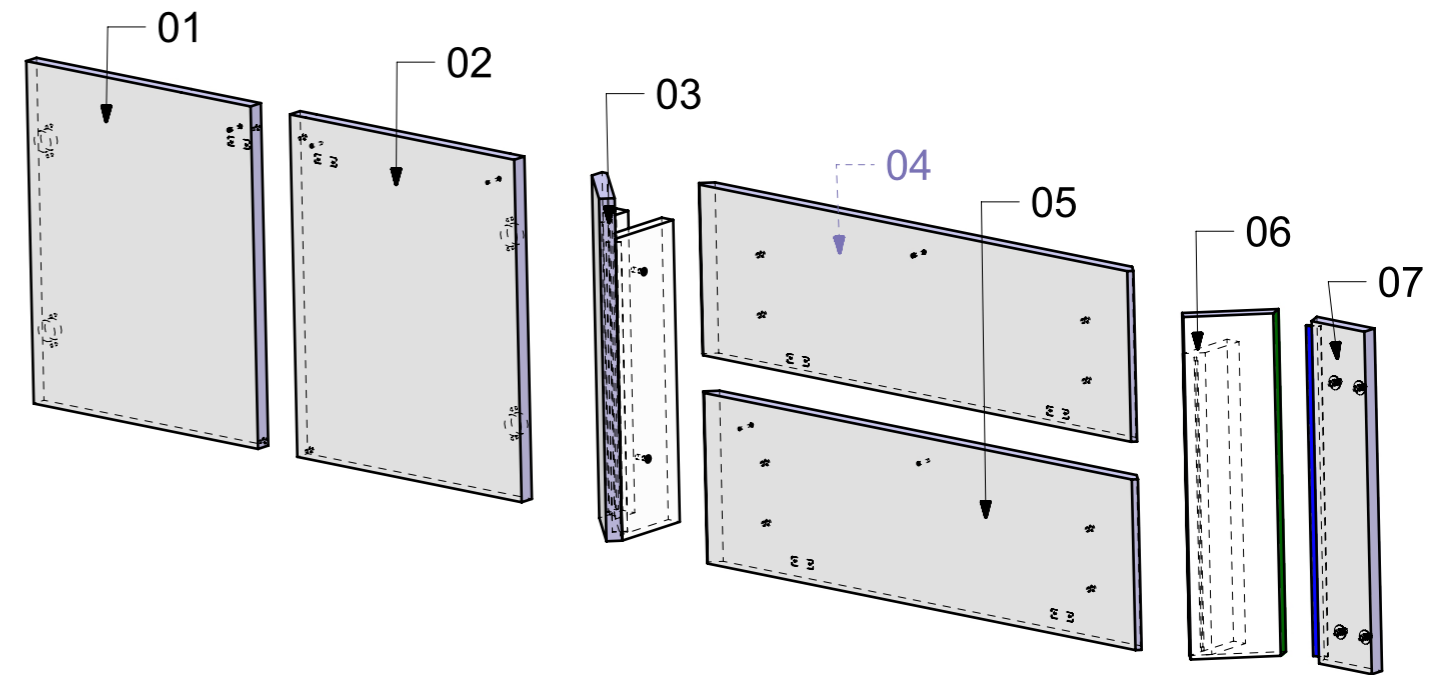
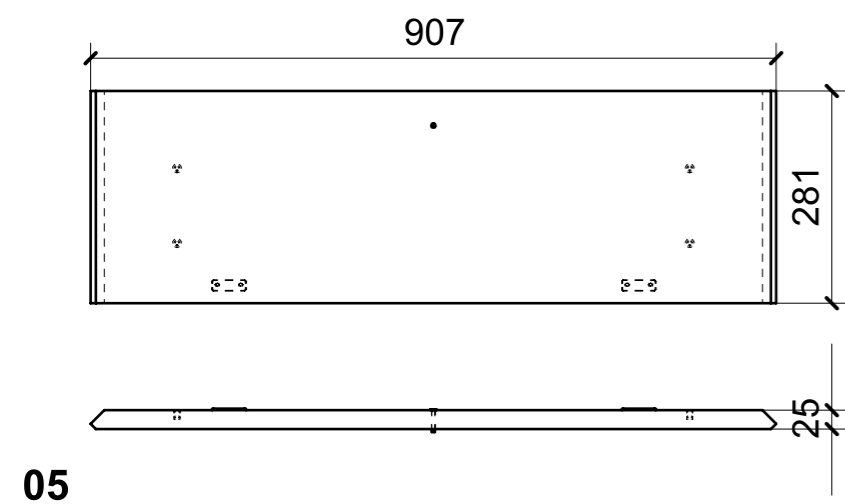
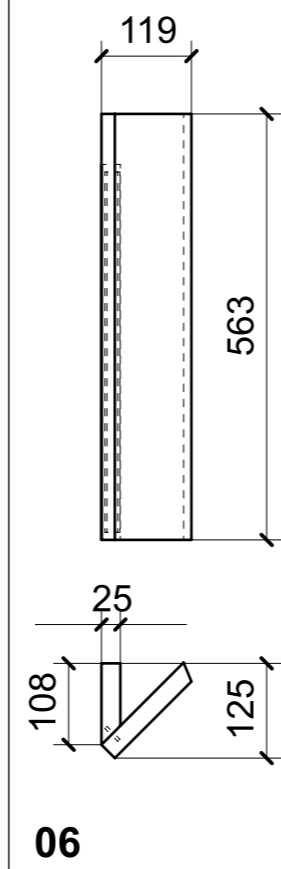
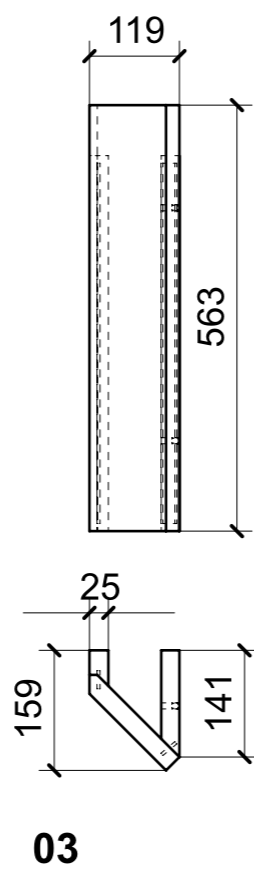
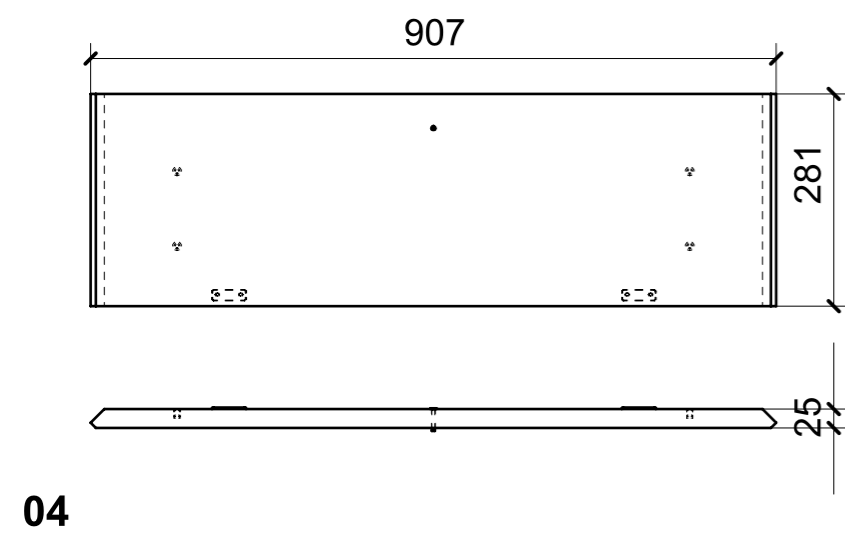
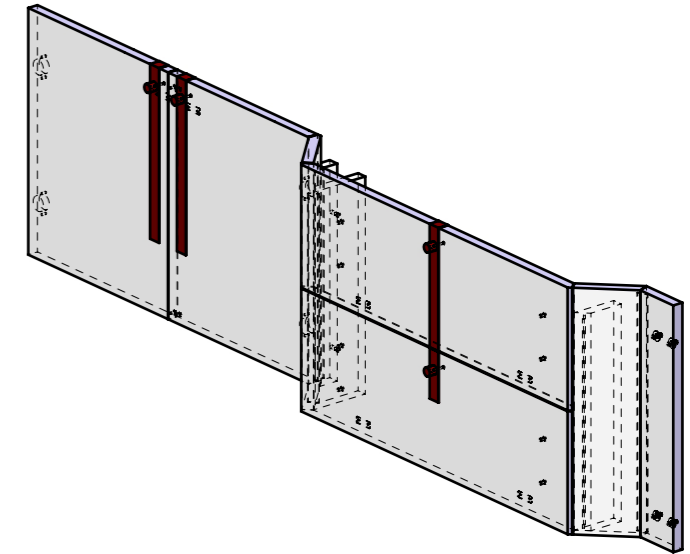

FERRAMENTA	QTY
BUSSOLA 5MA X 10 FORO DIAM.8	8
BUSSOLA 6MA X 10 FORO DIAM.8	2
GOMMINO PARACOLPO ANTA	4
MS INCASSO_ITALVIPLA_972_FMPC_M1B	4
PLACCHETTA COUNTER STEEL_TECHNOPARTNER_MC-JM49	6
VITE 4MA X 30 TESTA SVASATA ESAGONALE NERA	8

VERNICIATURA LASTRA/LACCATI:

● = VERNICIARE 1 LATO + FILI RASATI O BORDATI

NESSUN SIMBOLO = VERNICIARE 2 LATI + FILI RASATI O BORDATI