

LOCALE	CODICE	DESCRIZIONE COMPONENTE	FINITURA	Q.TA
SALONE	MD299_MF_SD01	MOBILE INGRESSO DX		1

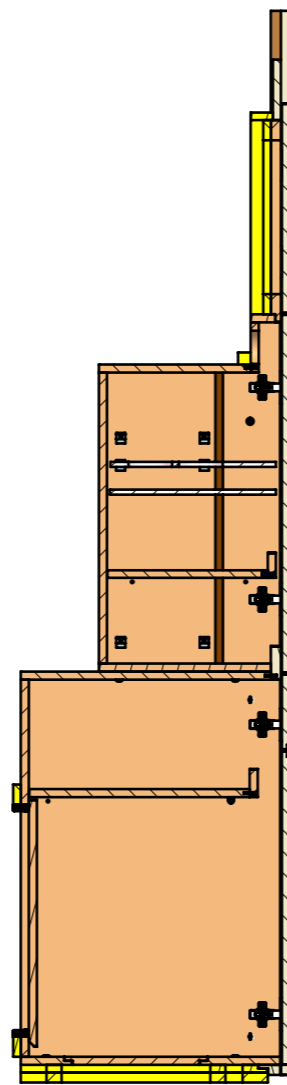

SECTION V-V

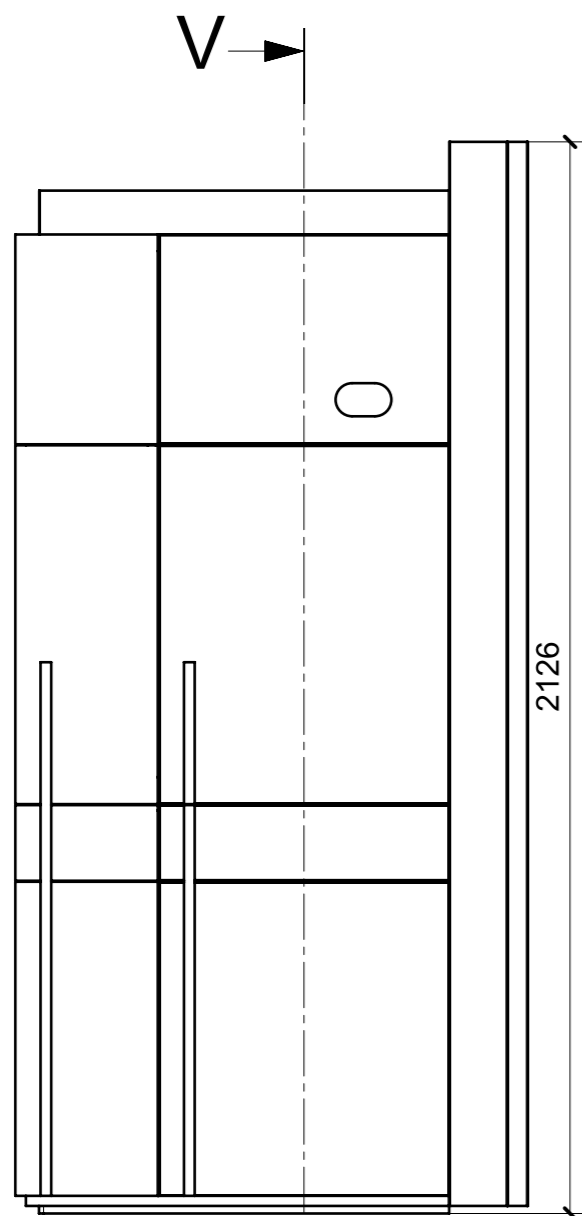
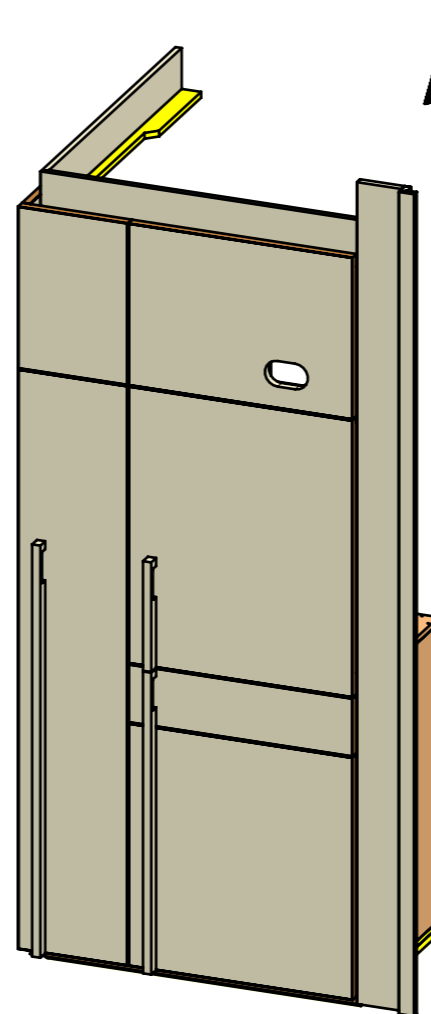
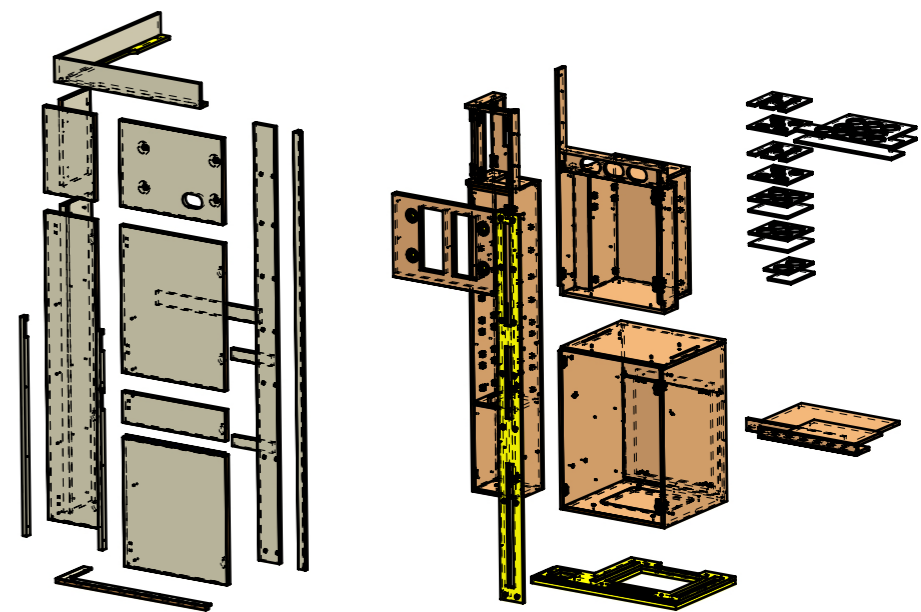
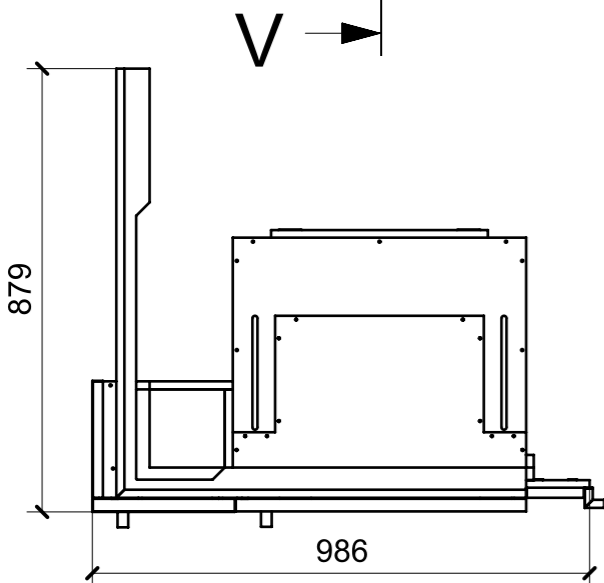

FERRAMENTA	QTY
FITLOCK F_MASCHERPA_6020101102	4
BASE_3_HAFELE_329_84_023	3
BASE_6_HAFELE_329_84_026	4
BUSSOLA 4MA X 10 FORO DIAM.6	9
BUSSOLA 5MA ANKOR BORGHI	6
BUSSOLA 5MA ANKOR BORGHI X CERNIERA PIANA	8
BUSSOLA 6MA X 10 FORO DIAM.8	33
CALAMITA SEALED MAGNETIC_TECNOPARTNER_MC-JM50-BL	6
CERNIERA 94° PIANA AMMORTIZZATA_HAFELE_329_49_310	7
CHIUSURA A SPINTA_TECNOPARTNER_SOU C3-203	12
FITLOCK M_MASCHERPA_3MM_6020202101	4
FM INCASSO_ITALVIPLA_973_FMPC_F1A	14
GOMMINO PARACOLPO ANTA	6
MS INCASSO_ITALVIPLA_972_FMPC_M1B	14
PLACCHETTA COUNTER STEEL_TECNOPARTNER_MC-JM49	6
REGGIRIPIANO QUADRO MM.10 X PLEX_ESSEPI_00171267	48
REGGIRIPIANO 1PERNO 1FORO_FBC_00257770	4
VITE 4MA X 30 TESTA SVASATA ESAGONALE NERA	9
VITE 4MAX8 ANKOR BORGHI	6
VITE 4MAX8 ANKOR BORGHI X CERNIERA PIANA	8

LOCALE	CODICE	DESCRIZIONE COMPONENTE	FINITURA	Q.TA
SALONE	MD299_MF_SH01	MOBILE TV		1

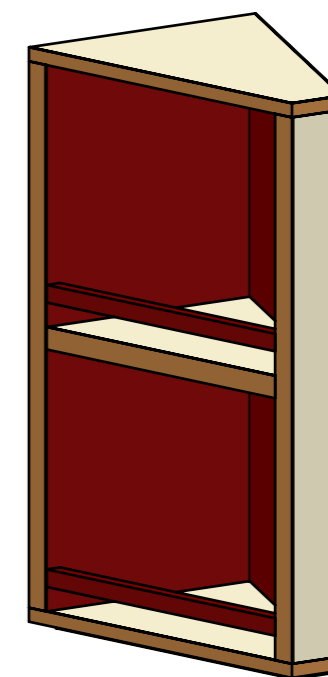
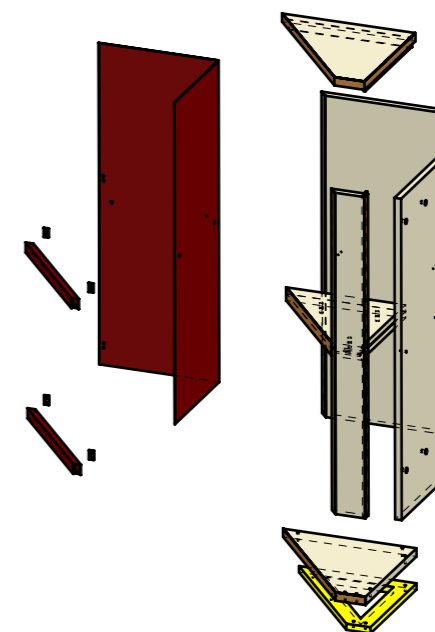
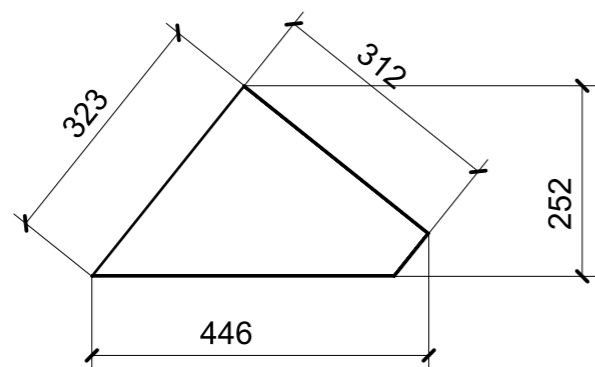
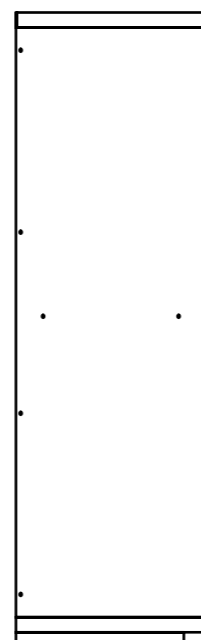
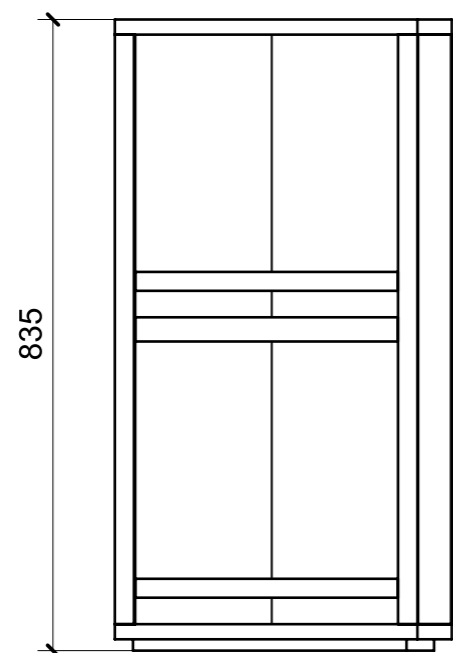

FERRAMENTA	QTY
VITE 6MA X 25 TESTA BOMBATA	14
BUSSOLA 6MA X 10 FORO DIAM.8	4

LOCALE	CODICE	DESCRIZIONE COMPONENTE	FINITURA	GR.
SALONE	MD299_MF_SSP01	FRONTALI CIELINO PLENUM SX CENTRO MURATA_STD_VAR 1		16

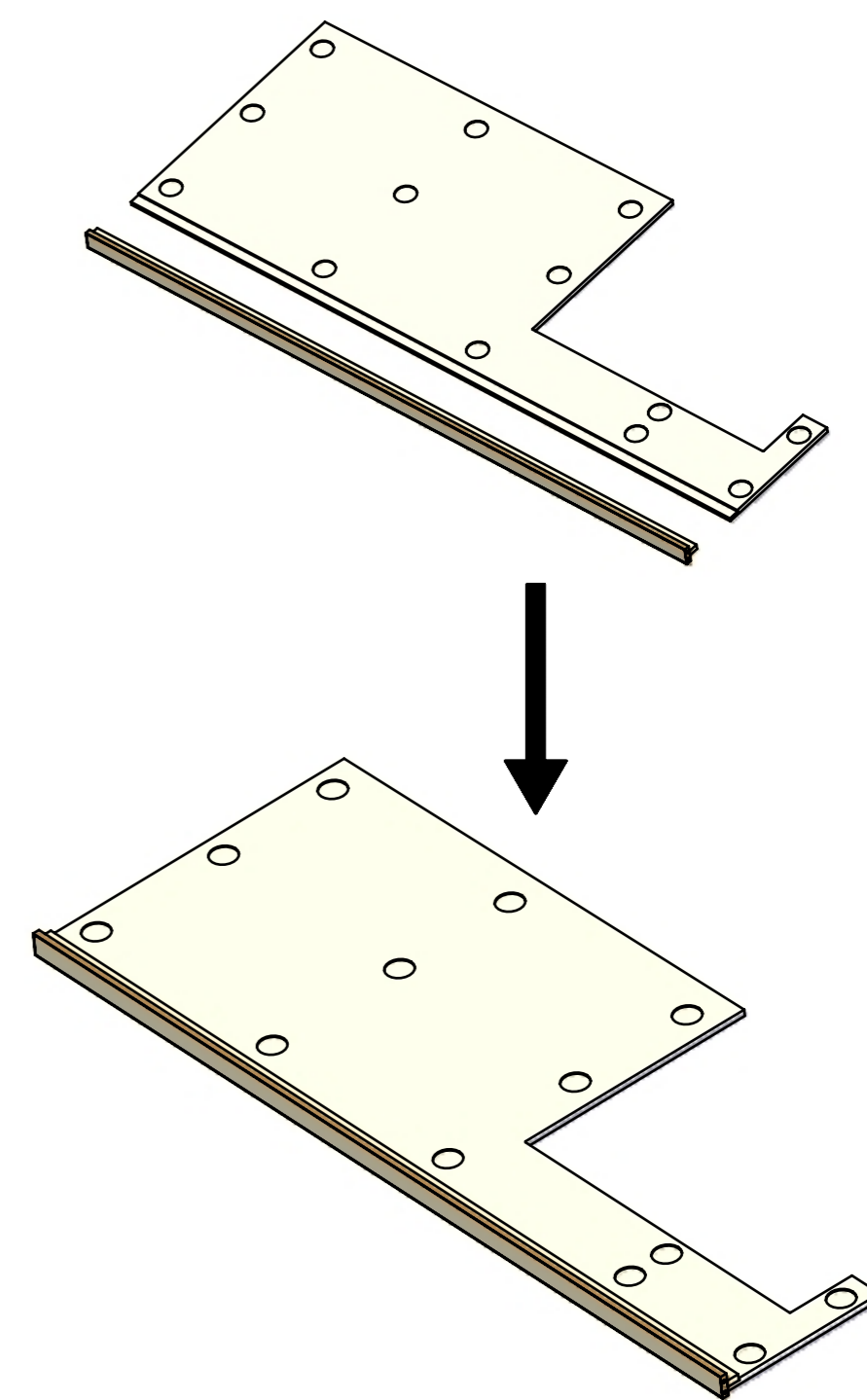
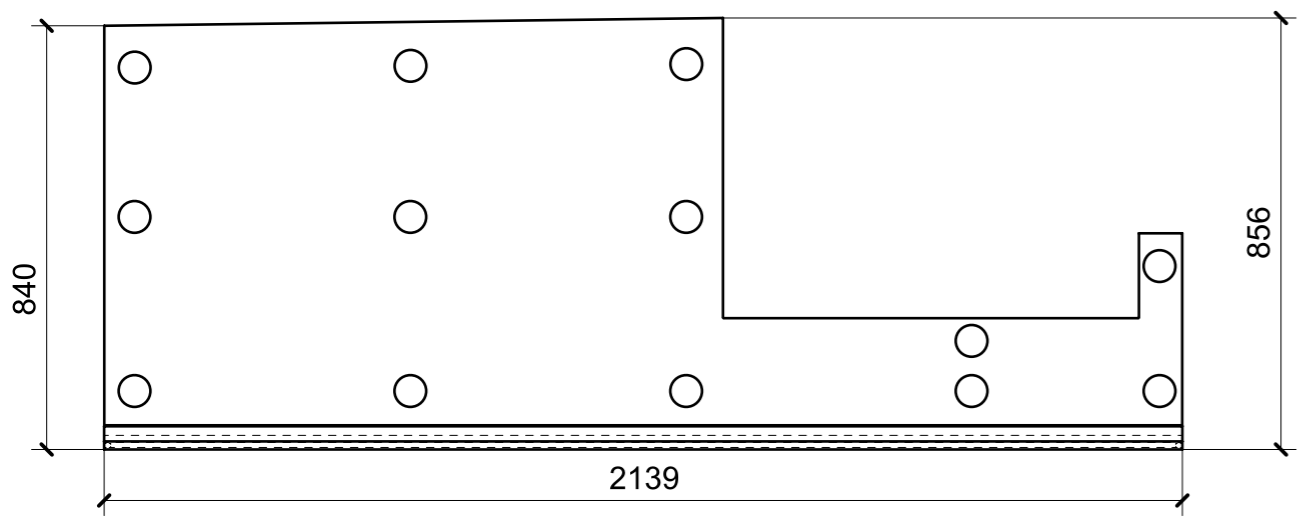
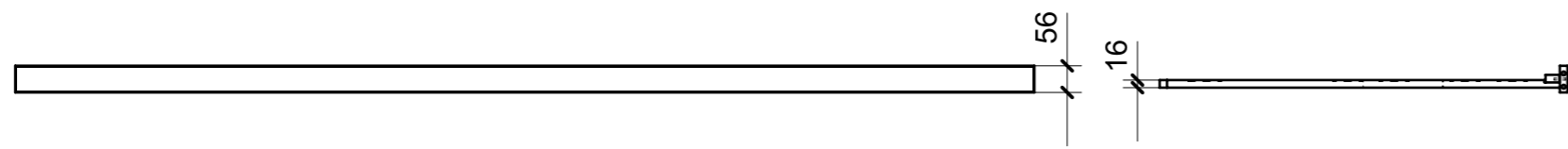

FERRAMENTA	QTY
FITLOCK M_MASCHERPA_3MM_6020202101	13

LOCALE	CODICE	DESCRIZIONE COMPONENTE	FINITURA	GR.
SALONE	MD299_MF_SPP01	FRONTALI CIELINO PLENUM SX CENTRO MURATA_STD_VAR 2		16

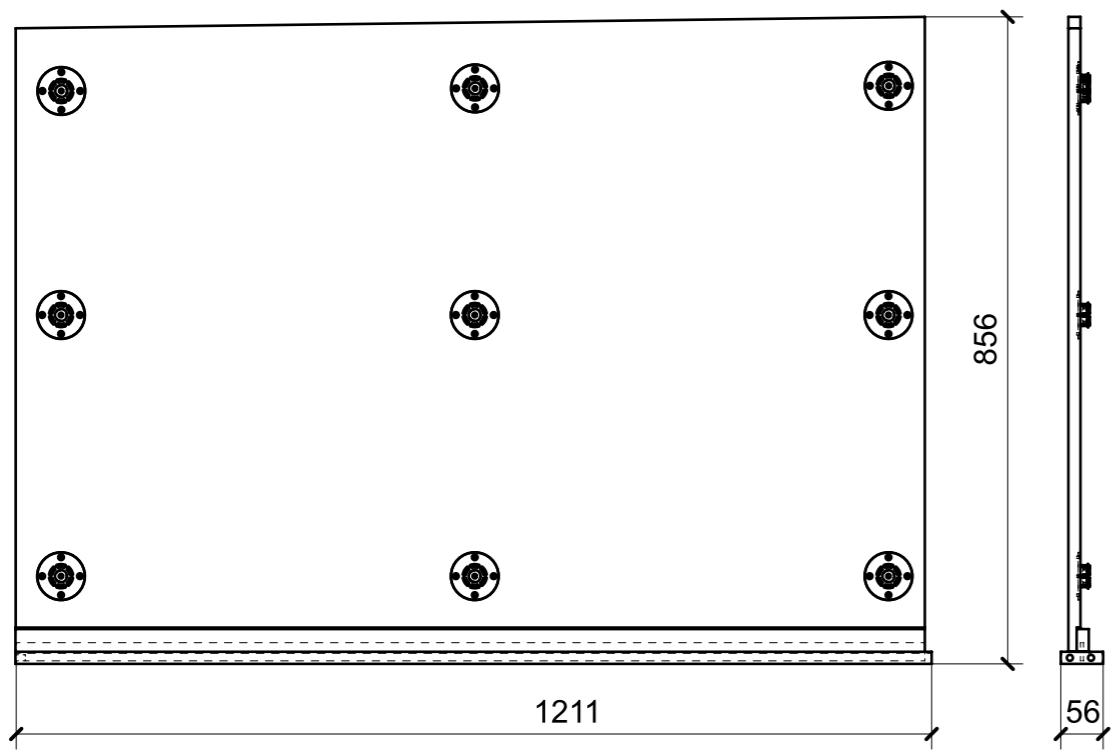

MF\_SPP01

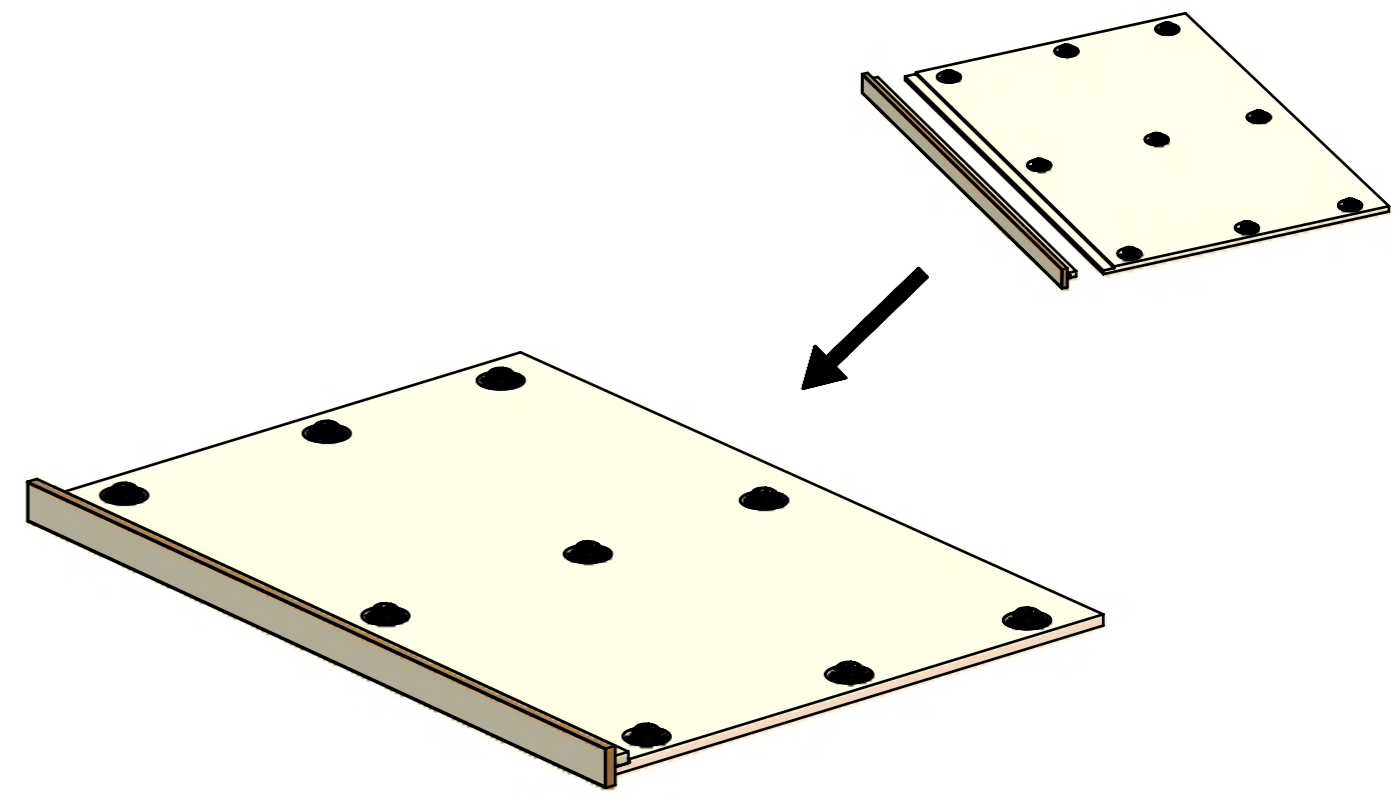

FERRAMENTA	QTY
FITLOCK M_MASCHERPA_3MM_6020202101	9

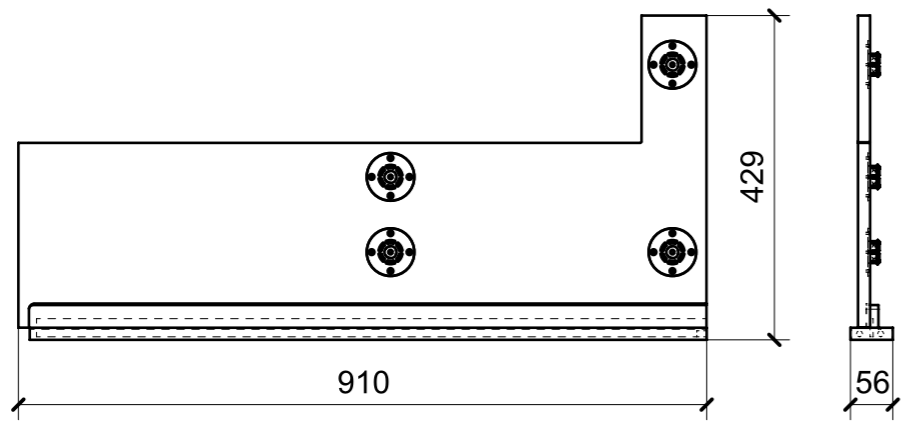

MF\_SPP02

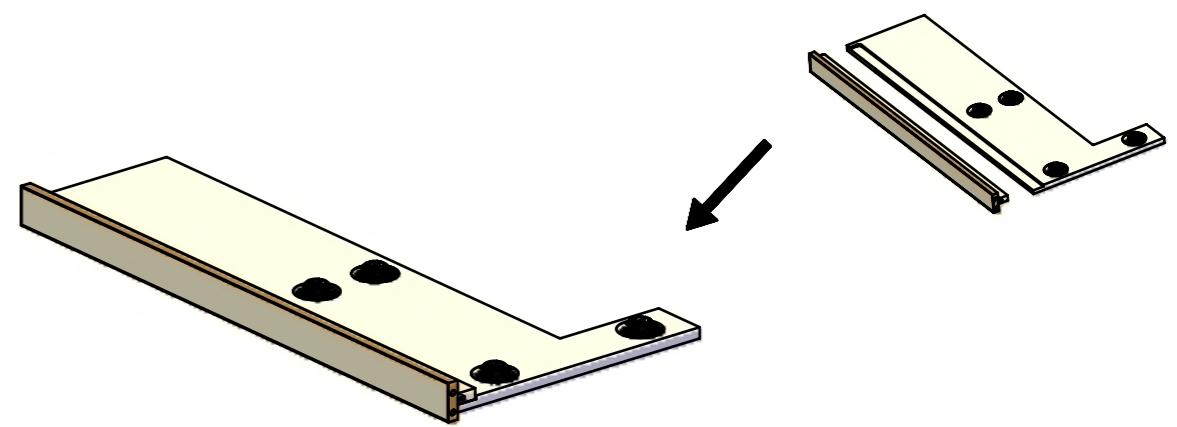

FERRAMENTA	QTY
FITLOCK M_MASCHERPA_3MM_6020202101	4

LOCALE	CODICE	DESCRIZIONE COMPONENTE	FINITURA	Q.TA
SALONE	MD299_MF_SQ01	CIELINO PLENUM SX POPPA		16

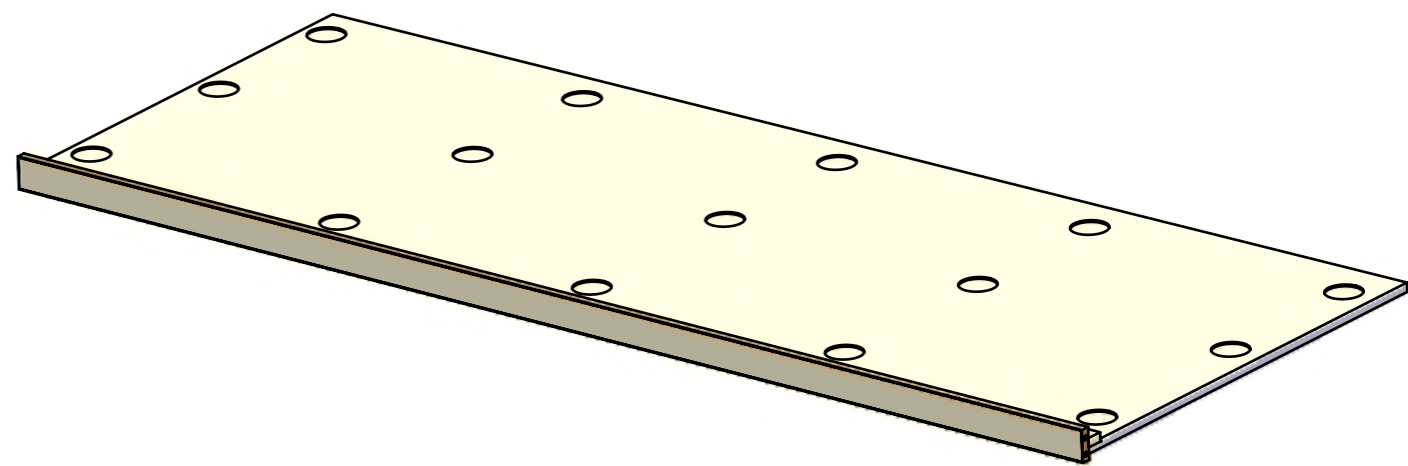
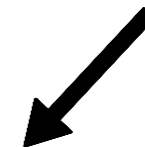
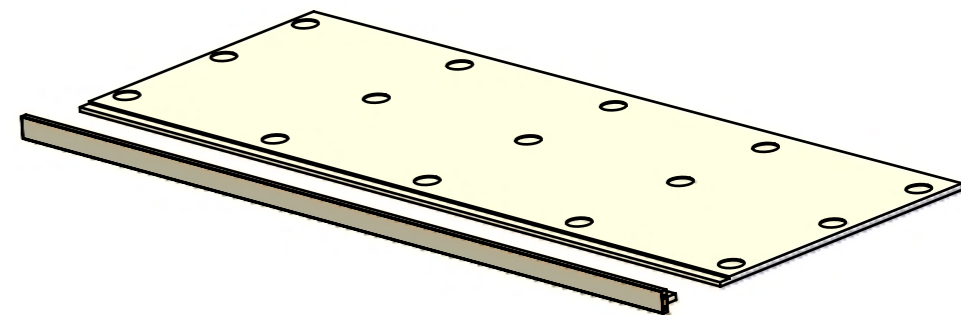
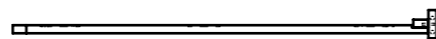
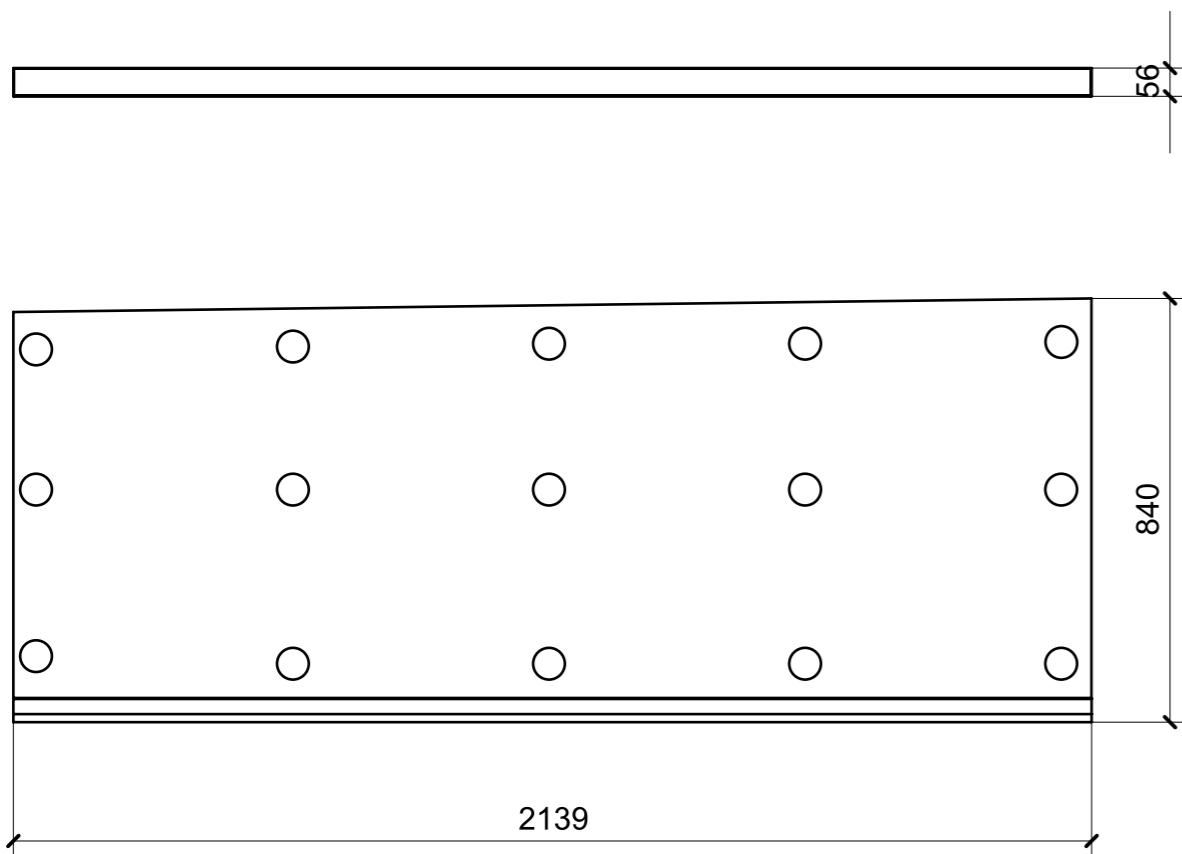

FERRAMENTA	QTY
FITLOCK M_MASCHERPA_3MM_6020202101	15

VERNICIATURA LASTRA/LACCATI:

● = VERNICIARE 1 LATO + FILI RASATI O BORDATI

NESSUN SIMBOLO = VERNICIARE 2 LATI + FILI RASATI O BORDATI

LOCALE	CODICE	DESCRIZIONE COMPONENTE	FINITURA	GR.
SALONE	MD299_MF_SR01	TRAVERSA INGRESSO SOFFITTO		16

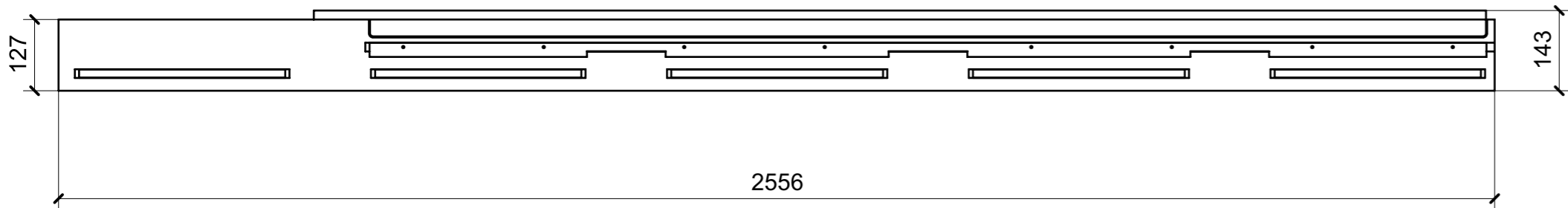
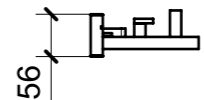
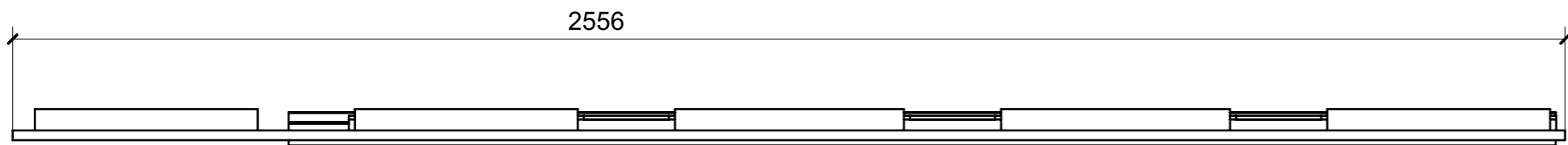
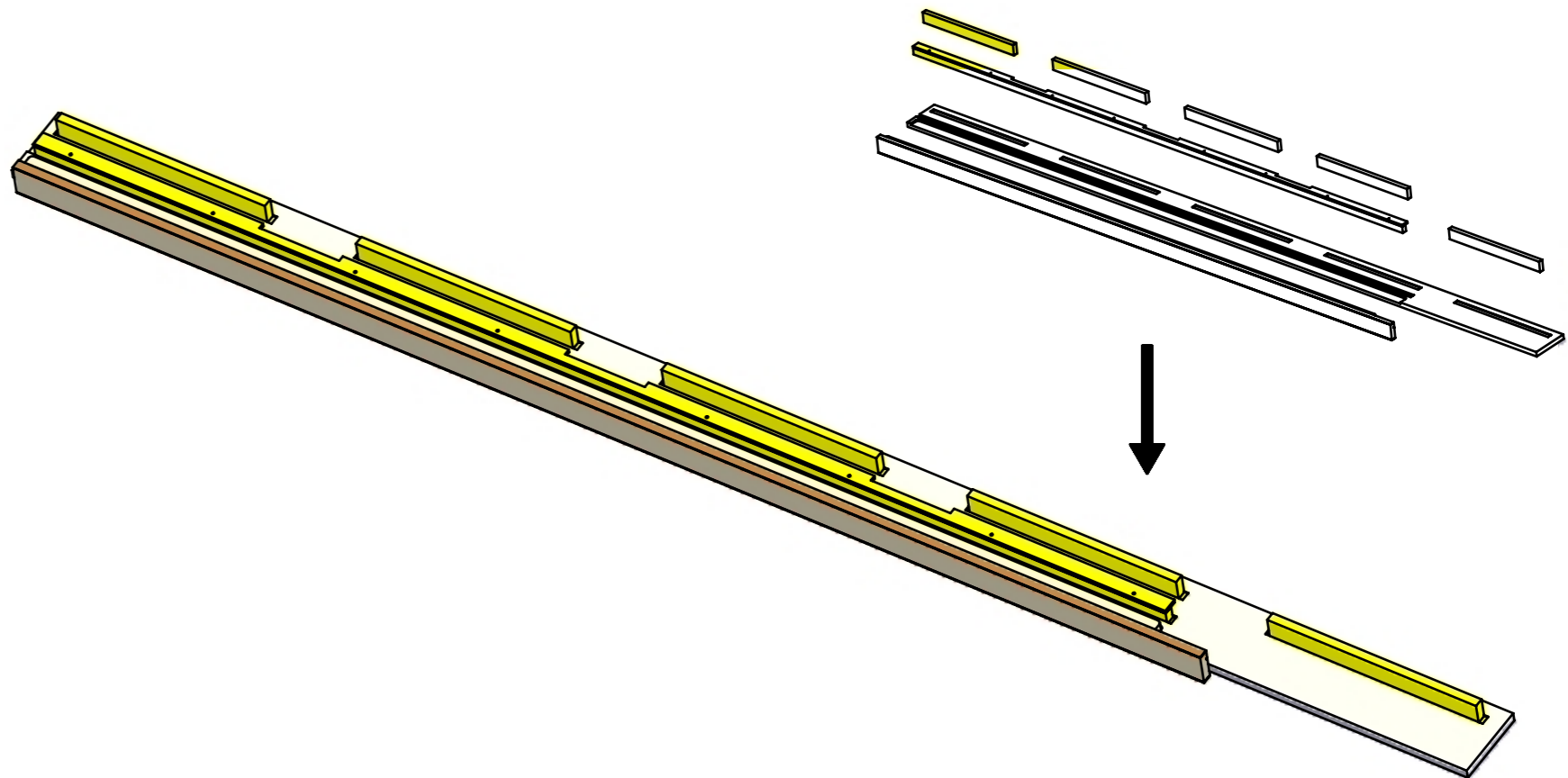

LOCALE	CODICE	DESCRIZIONE COMPONENTE	FINITURA	GR.
SALONE	MD299_MF_SS01	CIELINO PLENUM DX POPPA		16

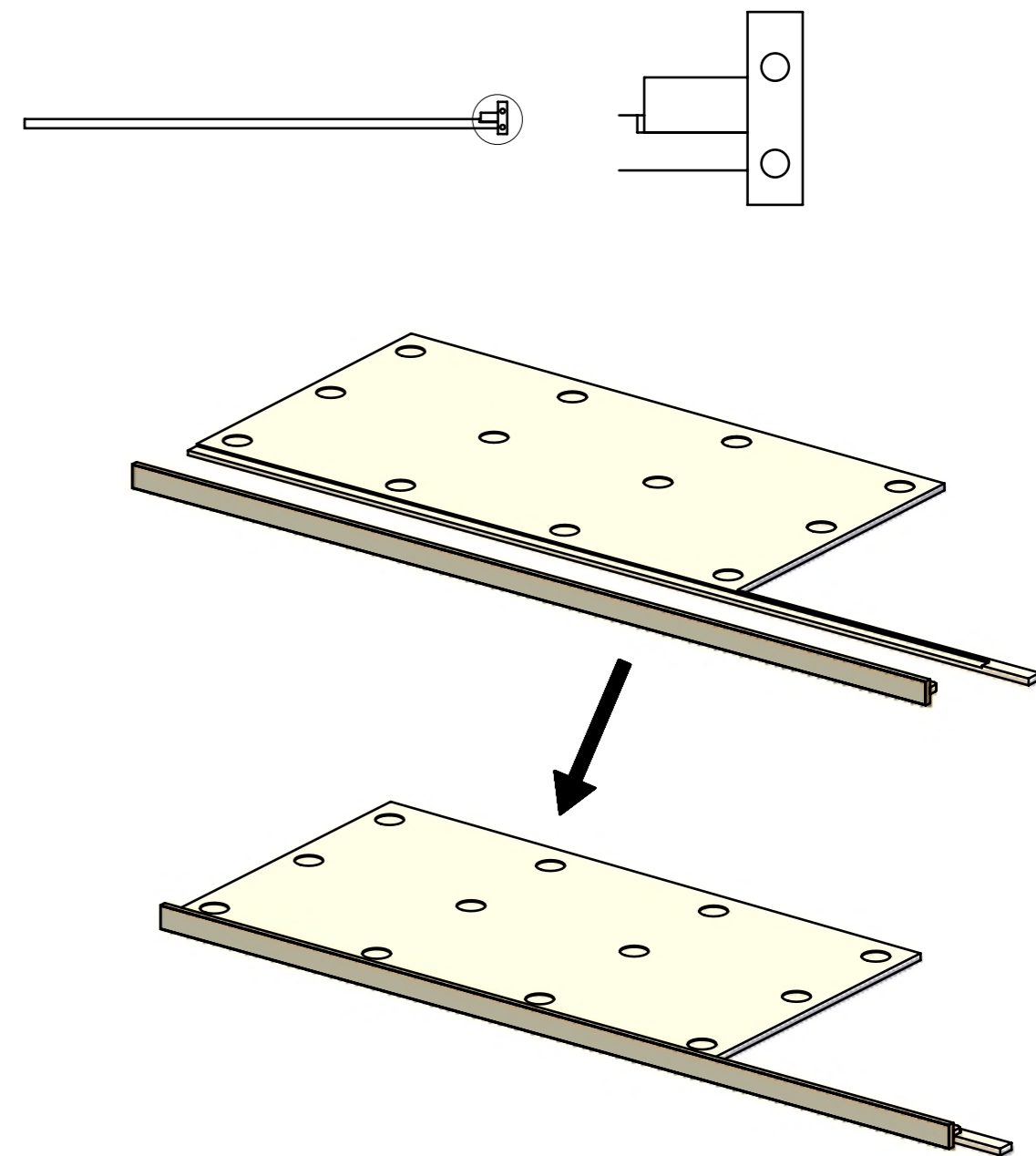
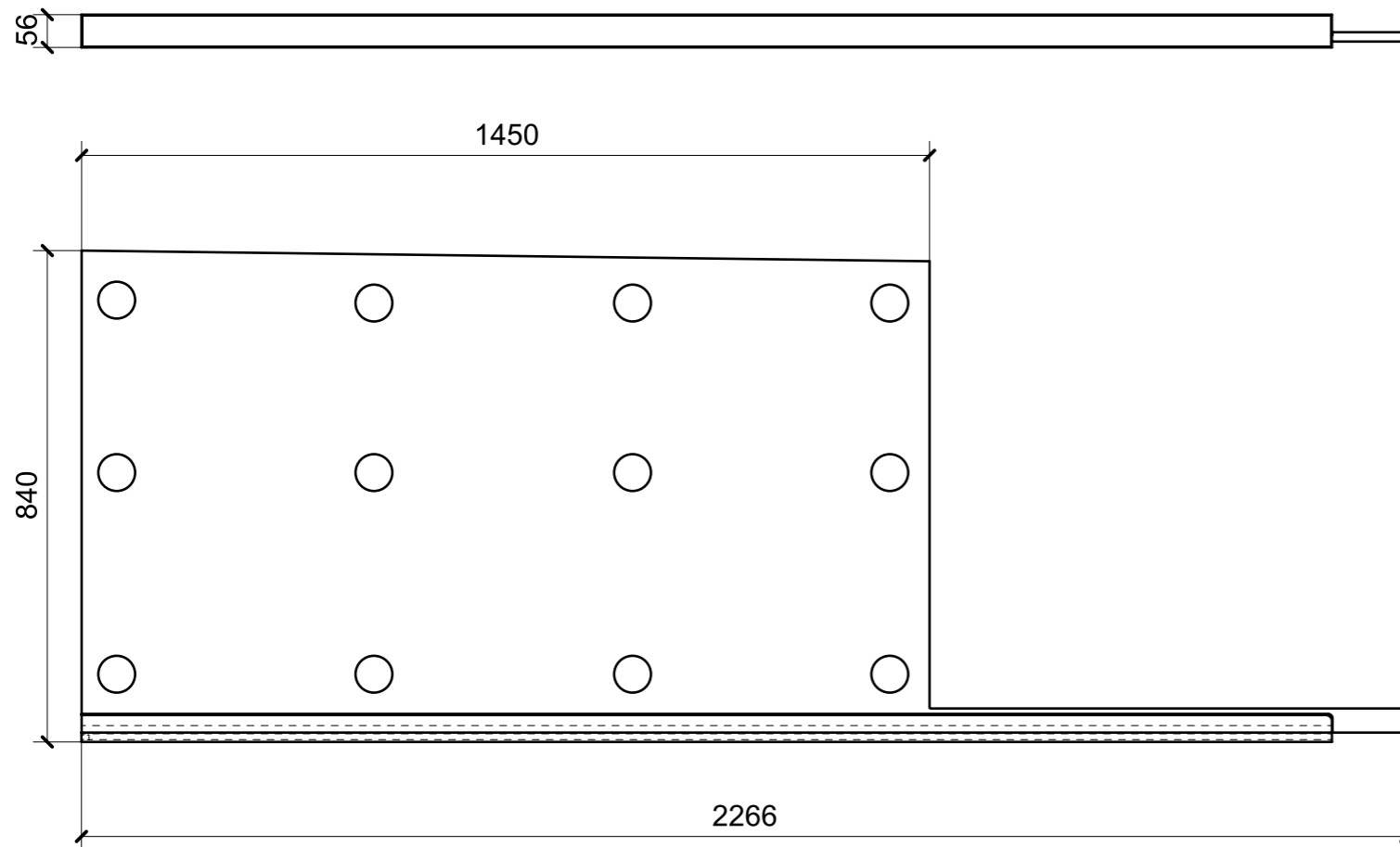

FERRAMENTA	QTY
FITLOCK M_MASCHERPA_3MM_6020202101	12

VERNICIATURA LASTRA/LACCATI:

● = VERNICIARE 1 LATO + FILI RASATI O BORDATI

NESSUN SIMBOLO = VERNICIARE 2 LATI + FILI RASATI O BORDATI

LOCALE	CODICE	DESCRIZIONE COMPONENTE	FINITURA	GR.
SALONE	MD299_MF_ST01	CIELINO PLENUM DX CENTRO MURATA		16

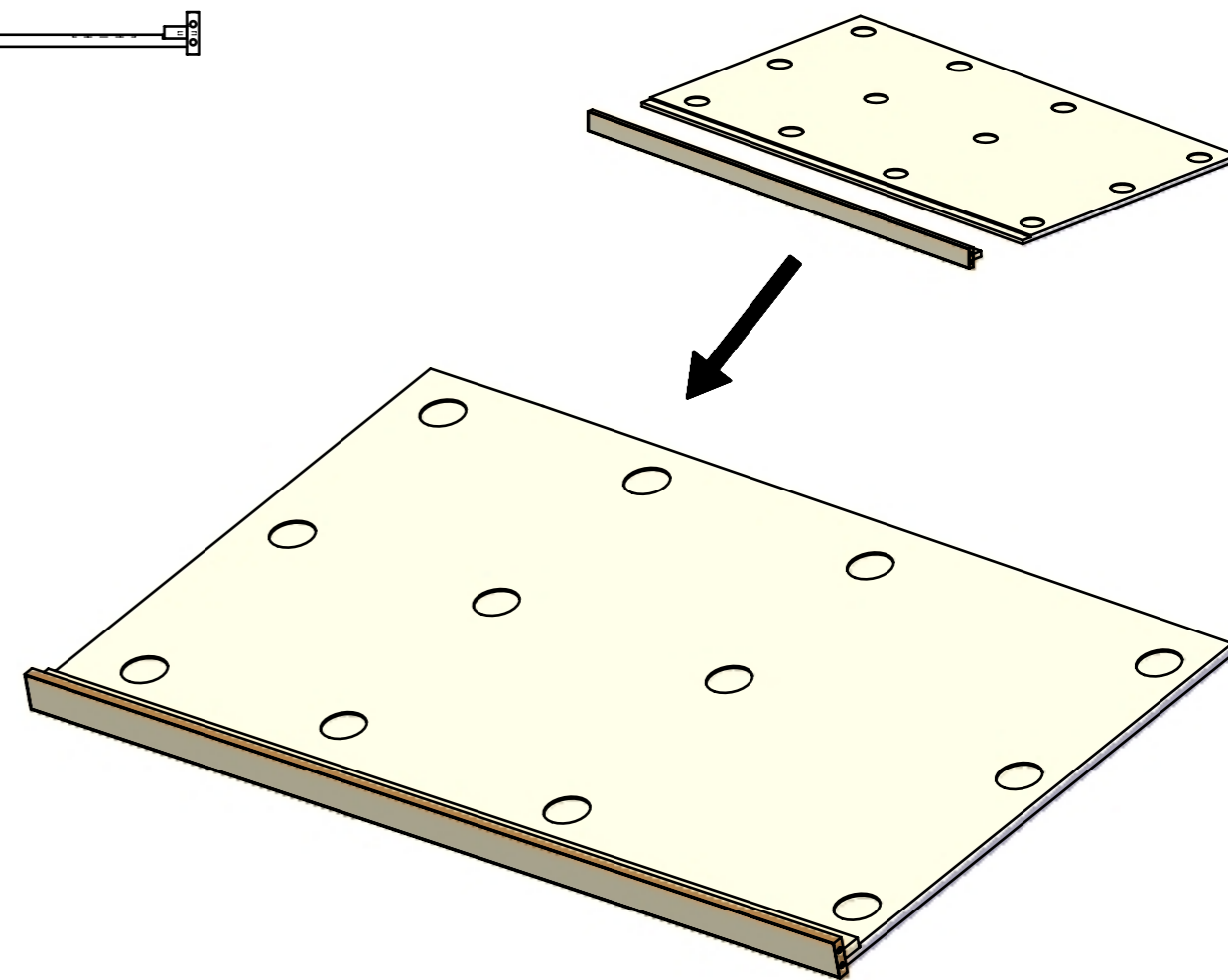
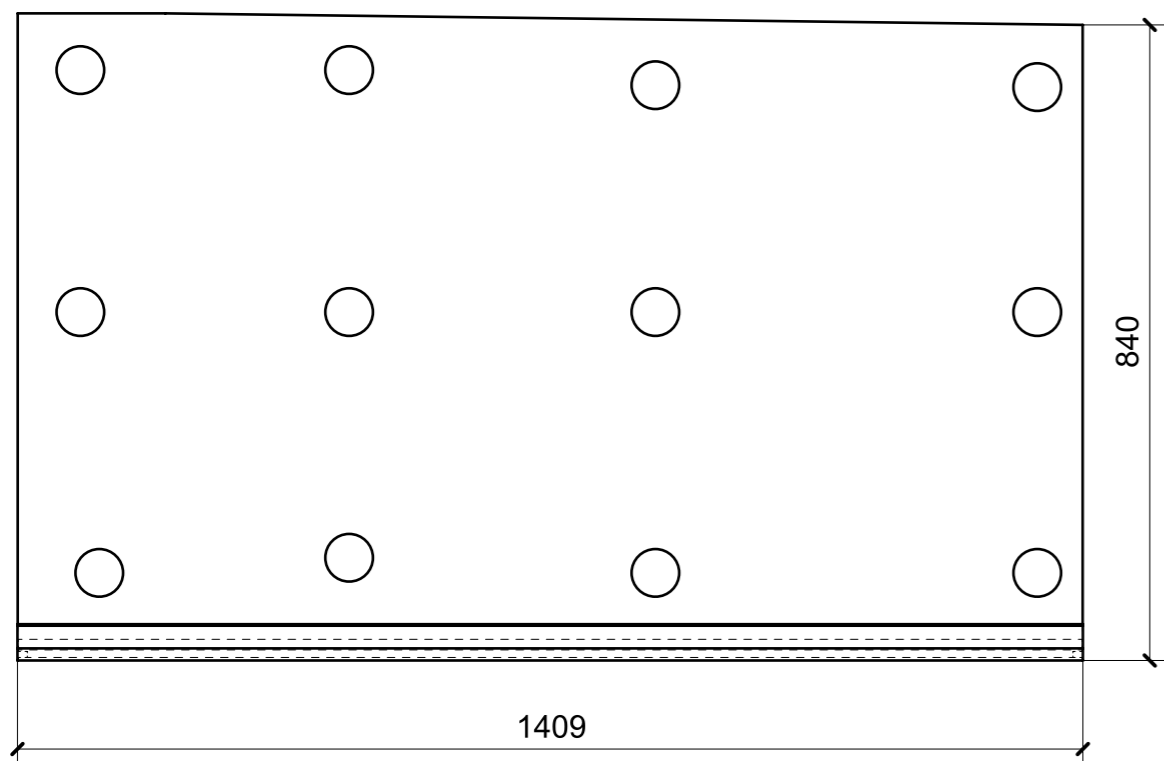
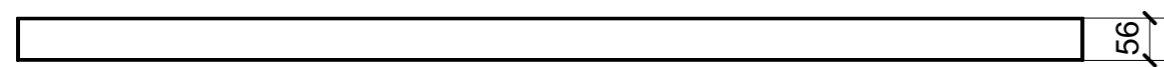

FERRAMENTA	QTY
FITLOCK M_MASCHERPA_3MM_6020202101	12

LOCALE	CODICE	DESCRIZIONE COMPONENTE	FINITURA	GR.
SALONE	MD299_MF_SW01	CIELINO PLENUM DX PRUA		16

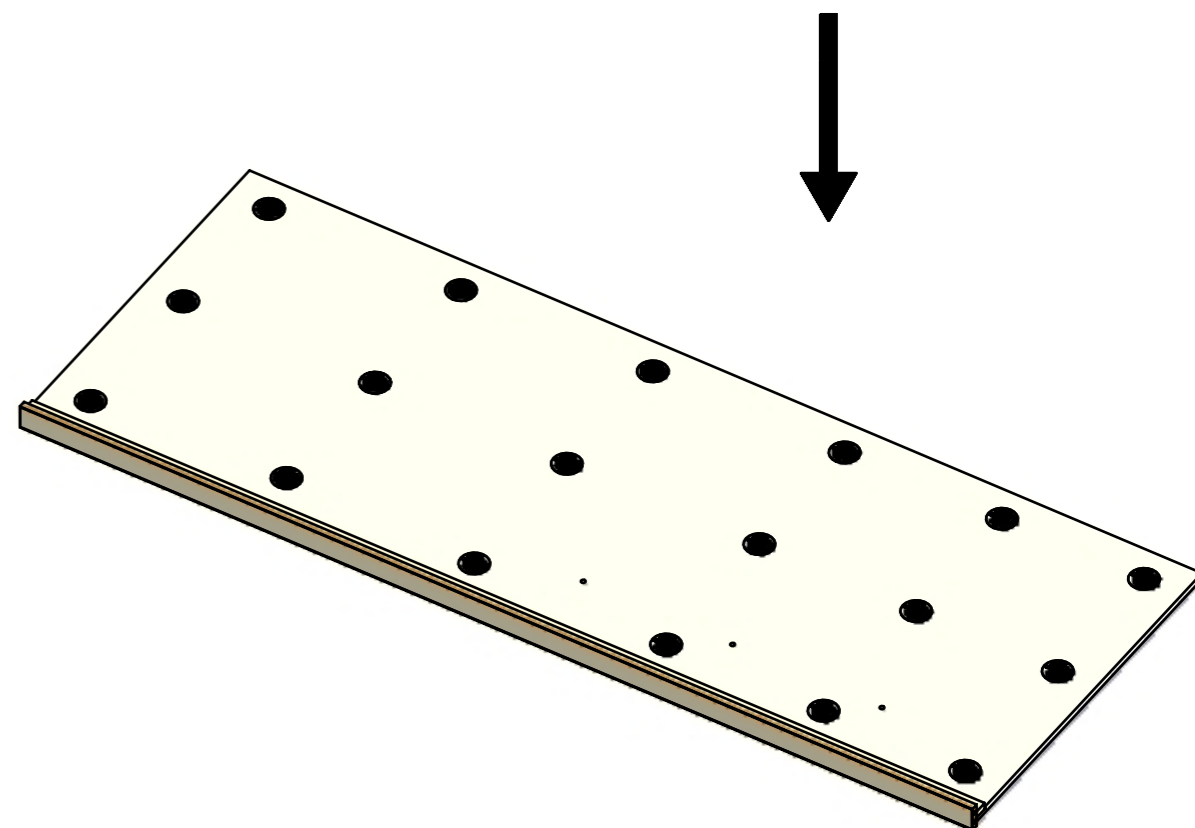
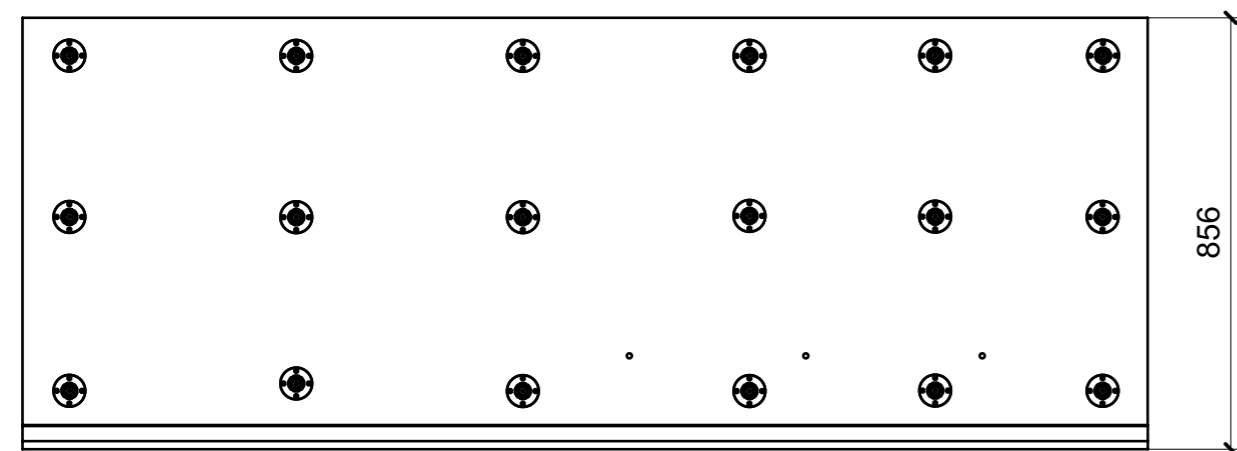
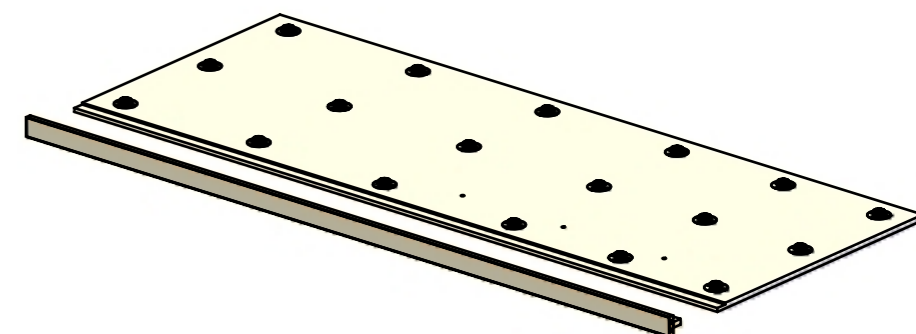
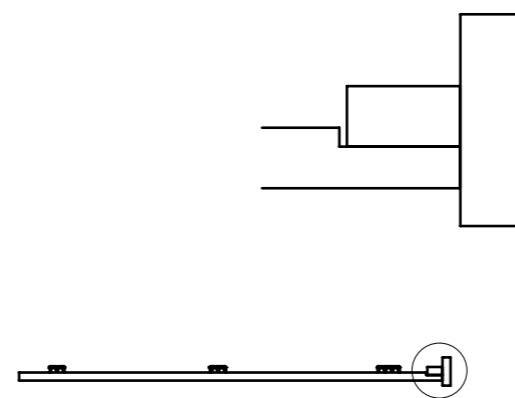
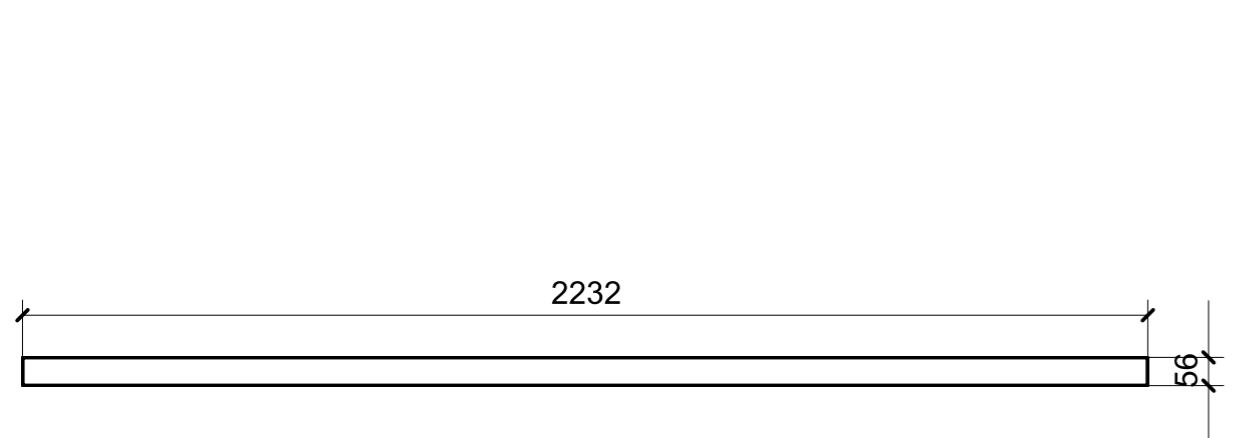

FERRAMENTA	QTY
FITLOCK M_MASCHERPA_3MM_6020202101	18

LOCALE	CODICE	DESCRIZIONE COMPONENTE	FINITURA	GR.
SALONE	MD299_MF_S SX01	FINITI CIELINO PLENUM SX PRUA_STD VAR 1		16

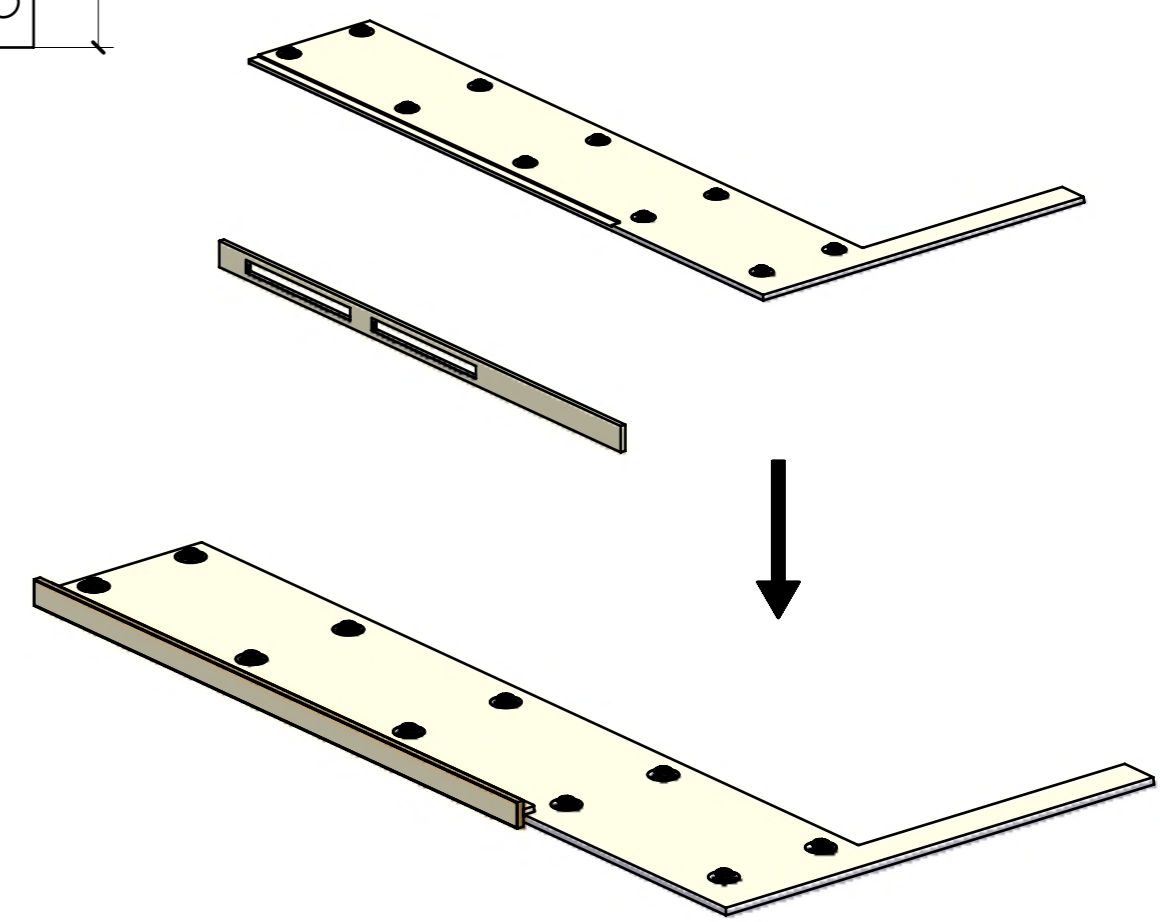
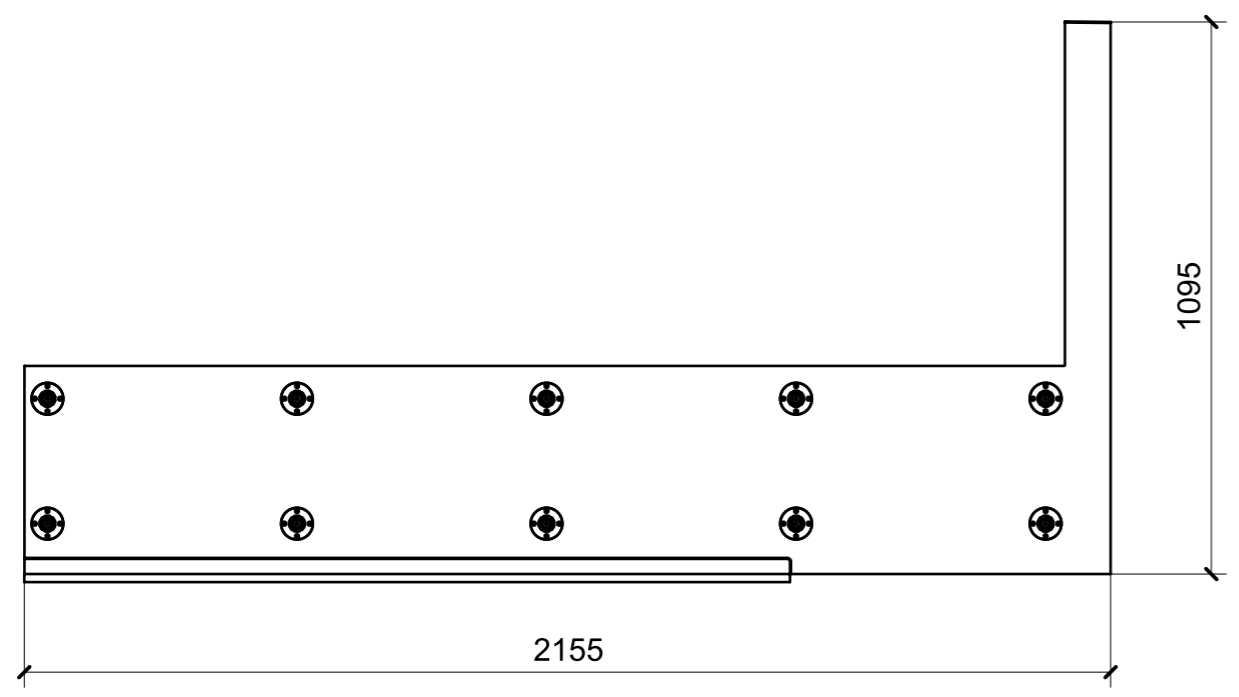
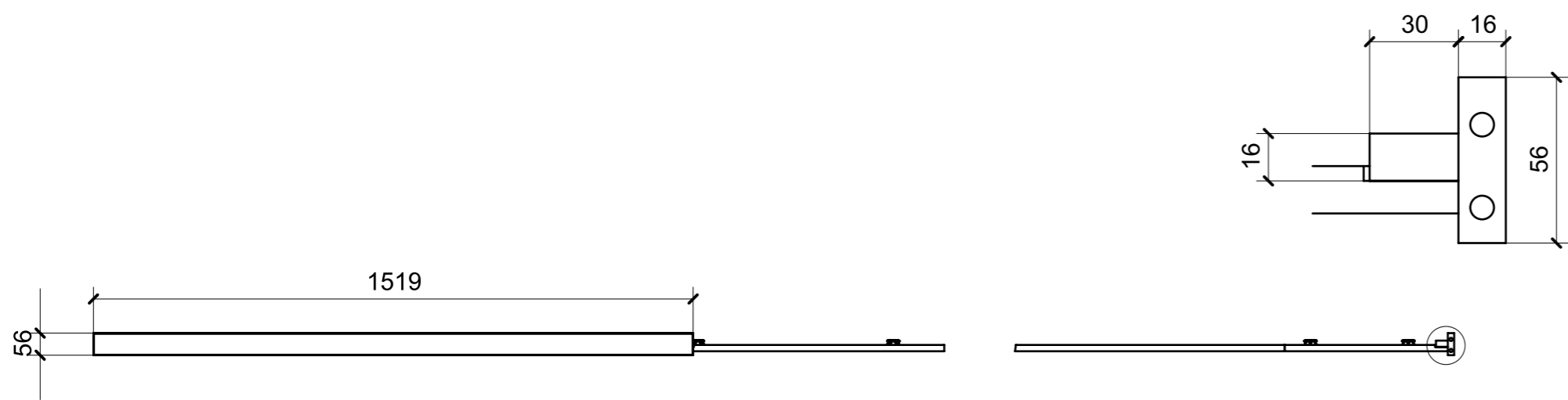

FERRAMENTA	QTY
FITLOCK M_MASCHERPA_3MM_6020202101	10

LOCALE	CODICE	DESCRIZIONE COMPONENTE	FINITURA	GR.
SALONE	MD299_MF_SXX01	FINITI CIELINO PLENUM SX PRUA_STD VAR 2		16

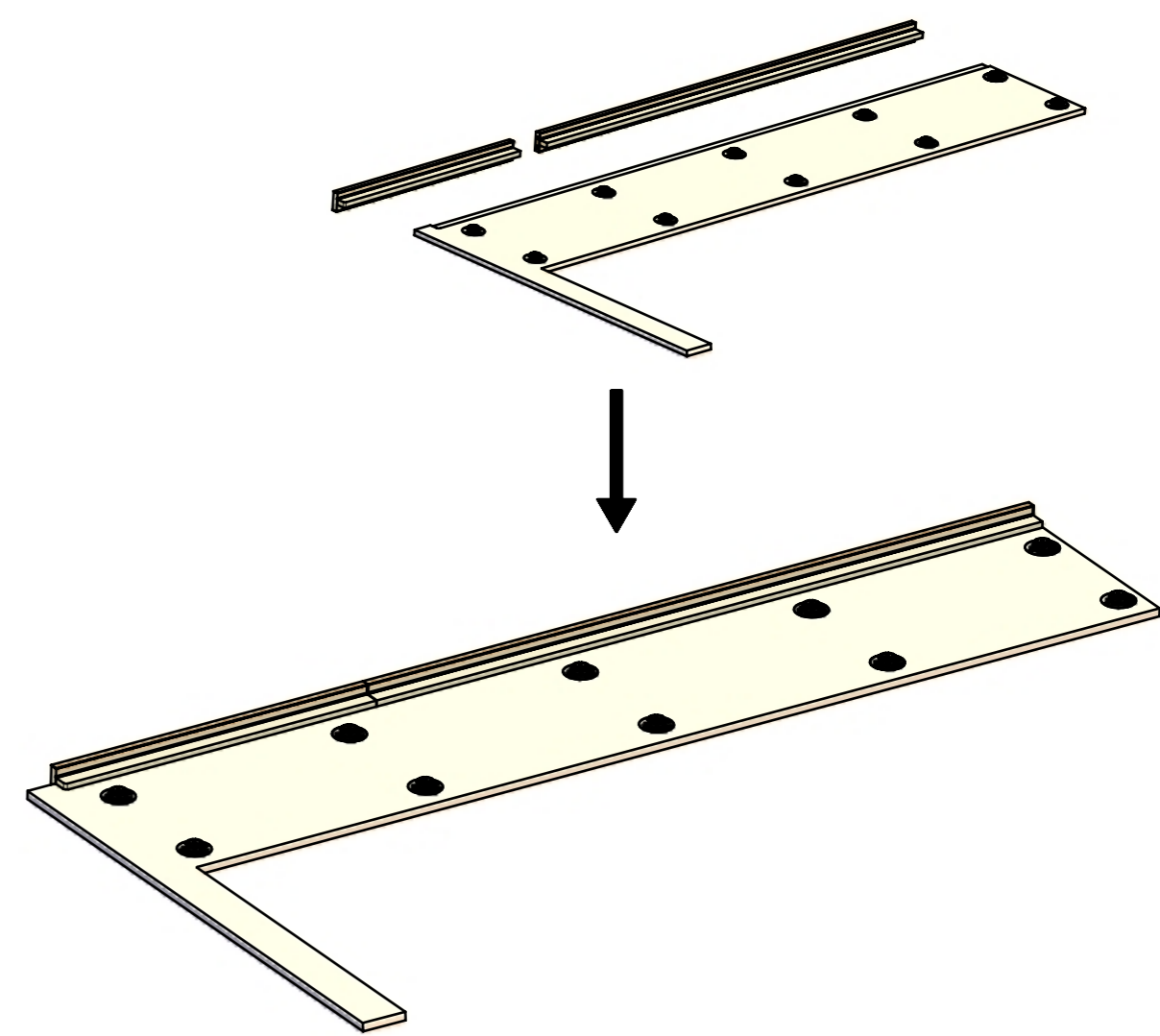
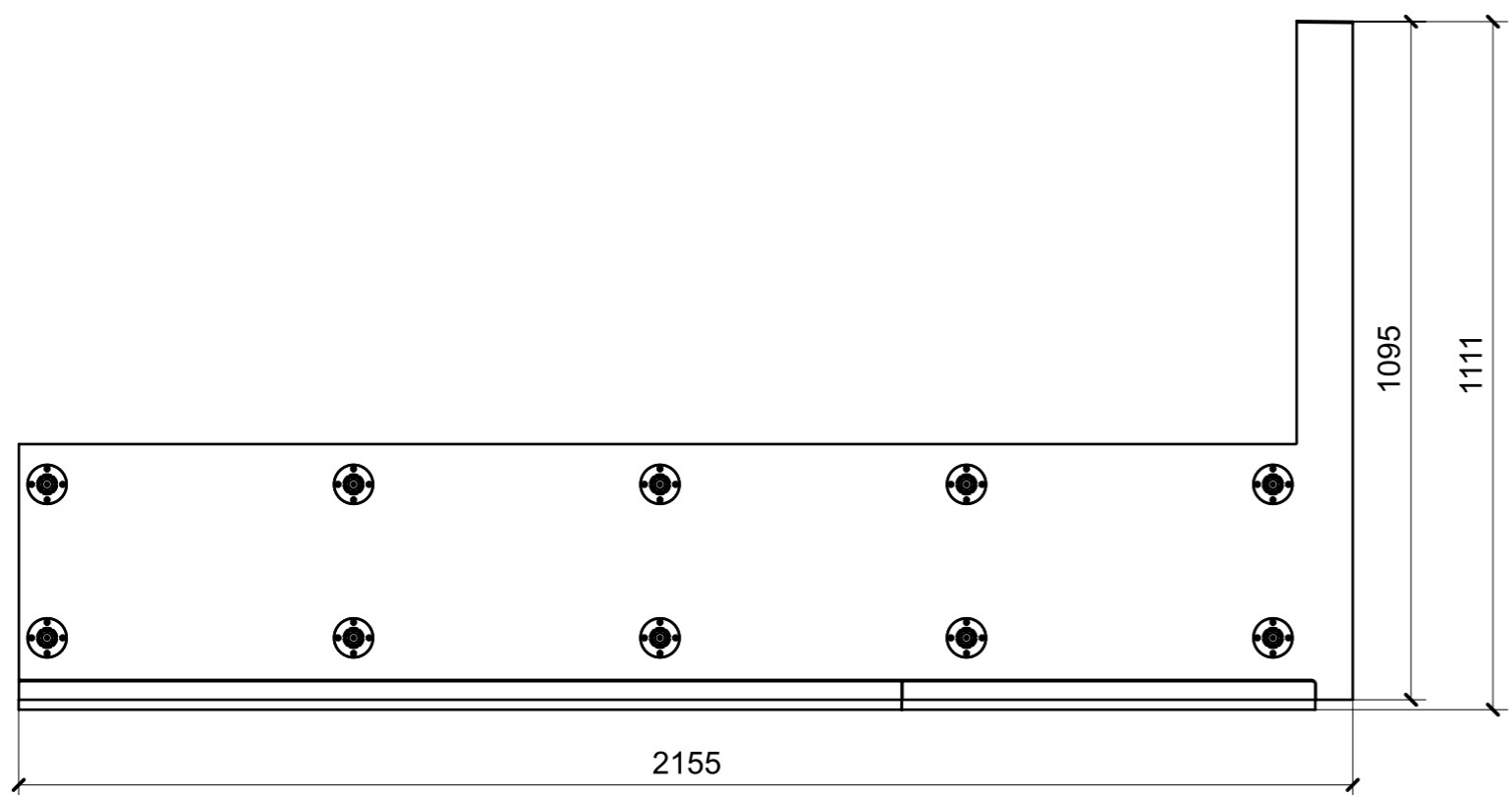
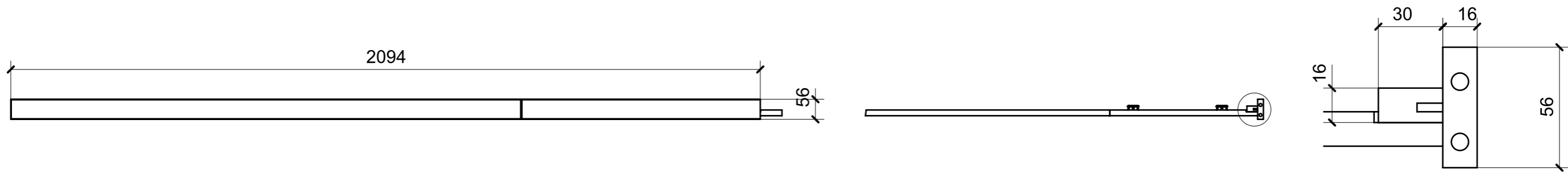

FERRAMENTA	QTY
FITLOCK M_MASCHERPA_3MM_6020202101	10

VERNICIATURA LASTRA/LACCATI:  
● = VERNICIARE 1 LATO + FILI RASATI O BORDATI      NESSUN SIMBOLO = VERNICIARE 2 LATI + FILI RASATI O BORDATI

LOCALE	CODICE	DESCRIZIONE COMPONENTE	FINITURA	Q.TA
SALONE	MD299_MF_SY01	CIELINO CENTRALE		1

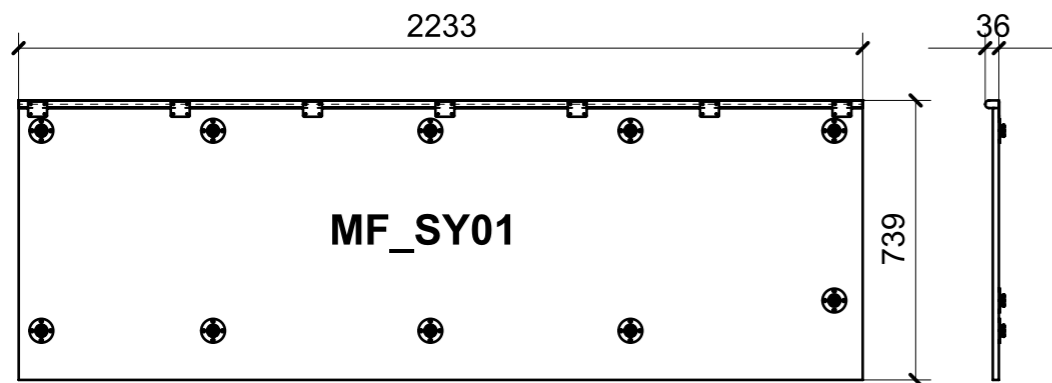

FERRAMENTA	QTY
PIASTRINA SP.1MM 50X40_FBC_ART_264 Z	7
FITLOCK M_MASCHERPA_3MM_6020202101	10

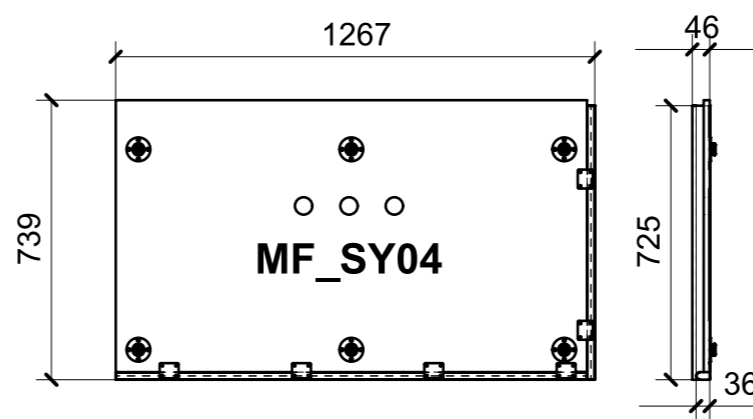

FERRAMENTA	QTY
PIASTRINA SP.1MM 50X40_FBC_ART_264 Z	6
FITLOCK M_MASCHERPA_3MM_6020202101	6

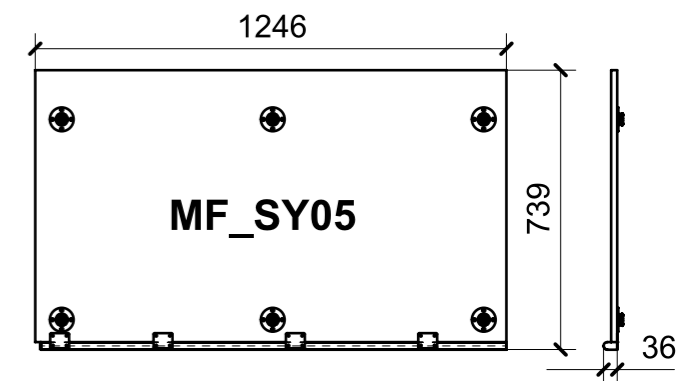

FERRAMENTA	QTY
PIASTRINA SP.1MM 50X40_FBC_ART_264 Z	4
FITLOCK M_MASCHERPA_3MM_6020202101	6

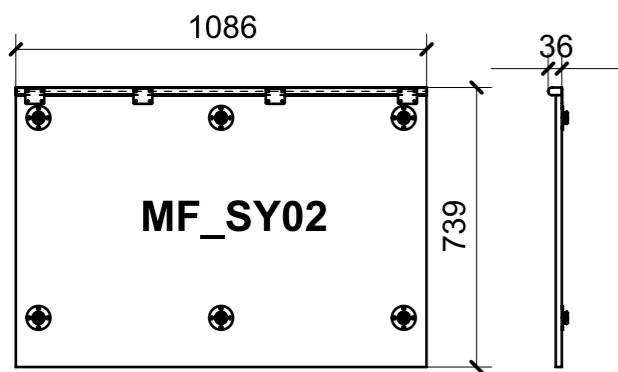

FERRAMENTA	QTY
PIASTRINA SP.1MM 50X40_FBC_ART_264 Z	4
FITLOCK M_MASCHERPA_3MM_6020202101	6

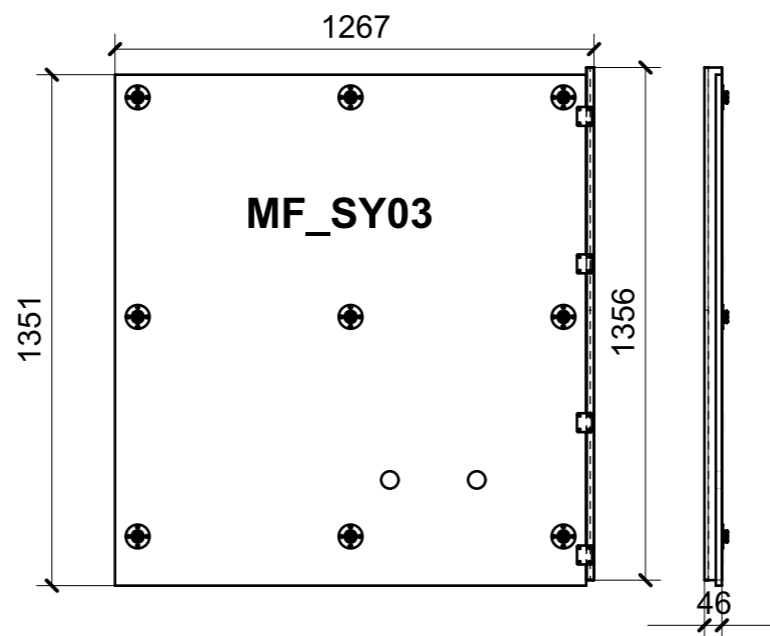

FERRAMENTA	QTY
PIASTRINA SP.1MM 50X40_FBC_ART_264 Z	4
FITLOCK M_MASCHERPA_3MM_6020202101	9

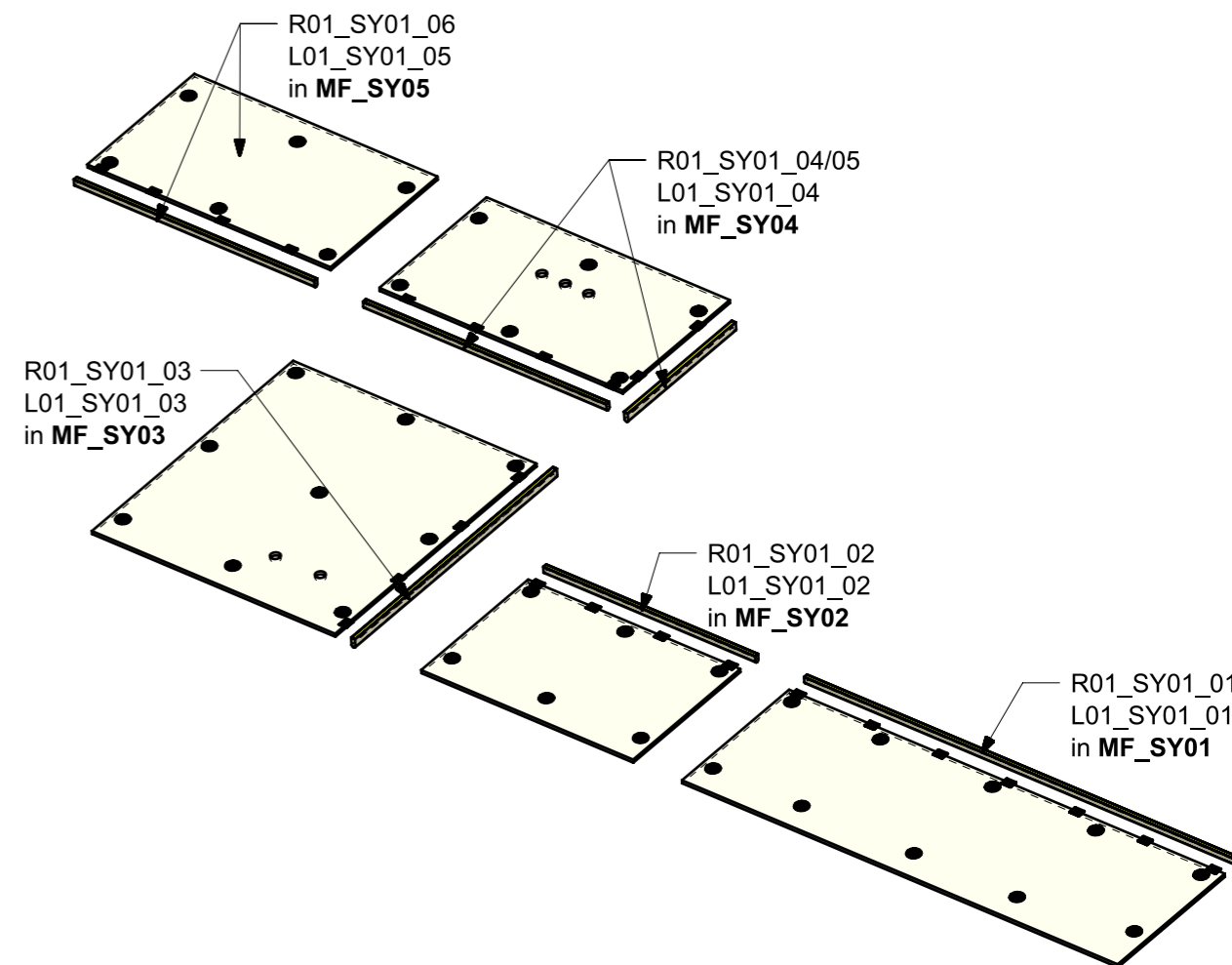

LOCALE	CODICE	DESCRIZIONE COMPONENTE	FINITURA	Q.TA
SALONE	MD299_MF_SSC01	TAVOLO HI-LOW_STD VAR 2		1

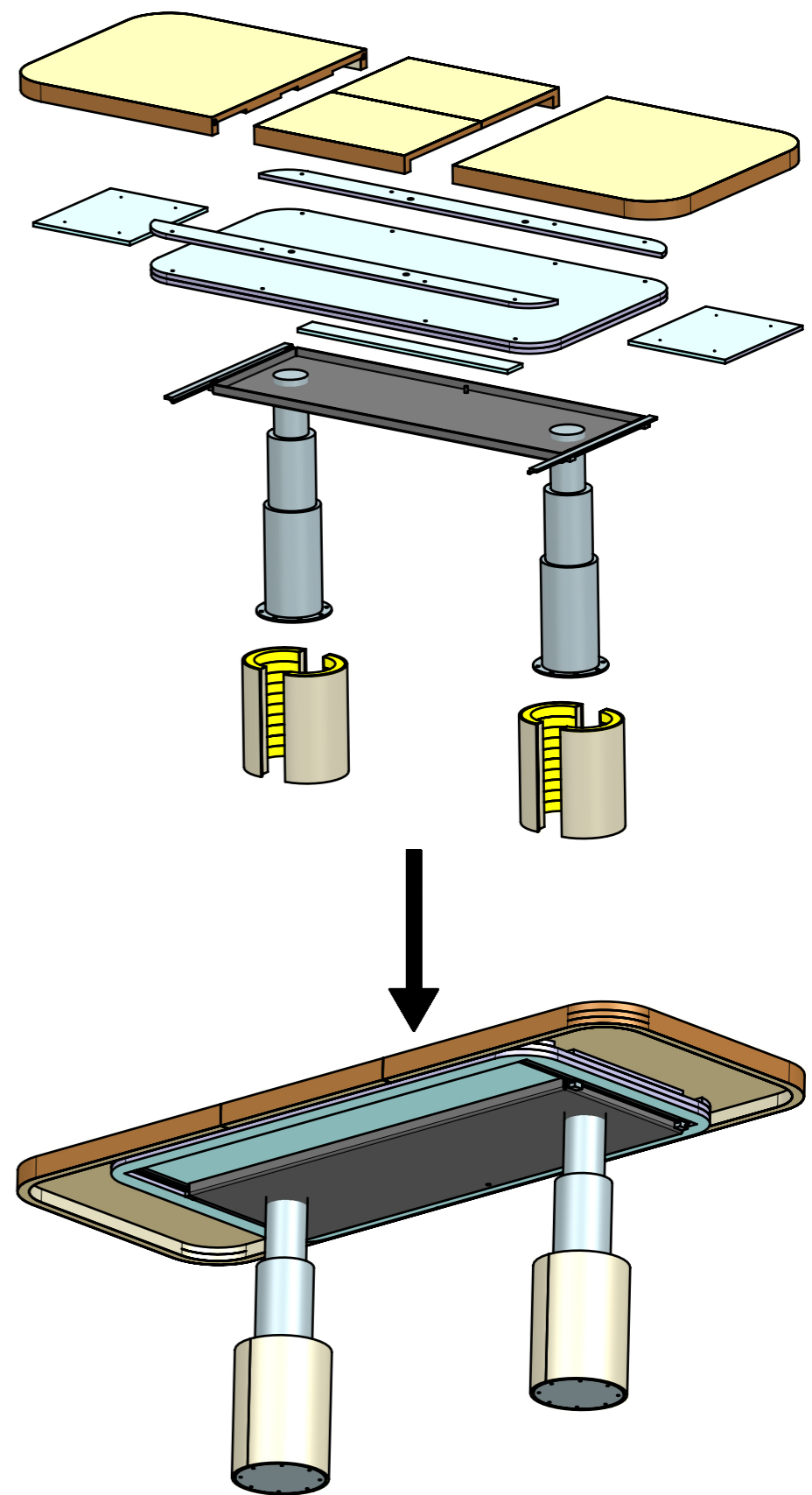
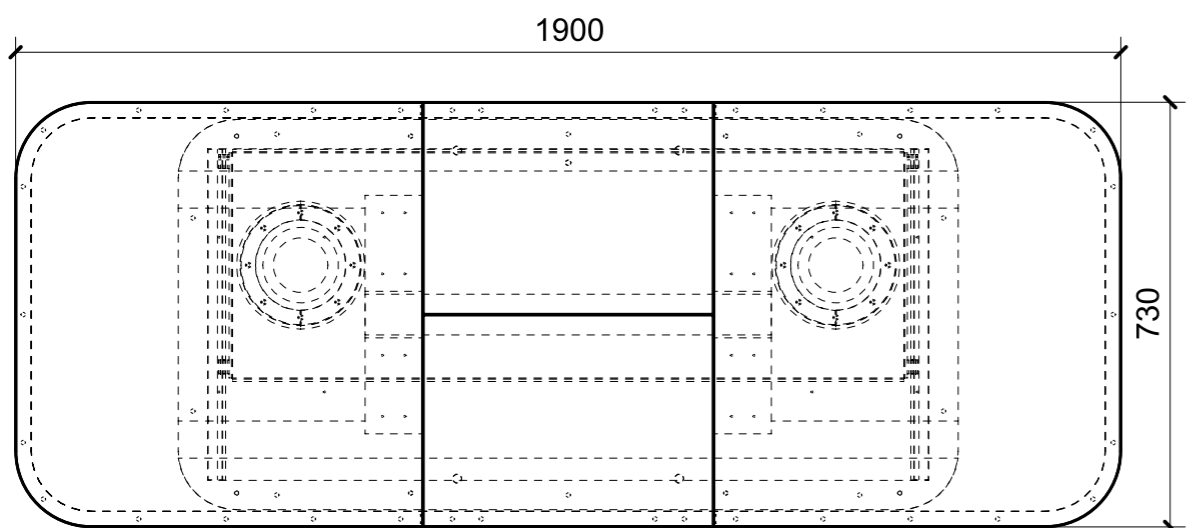
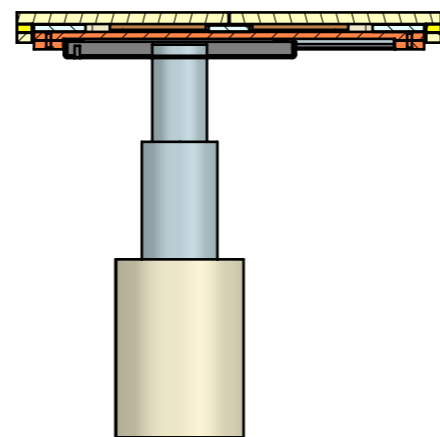
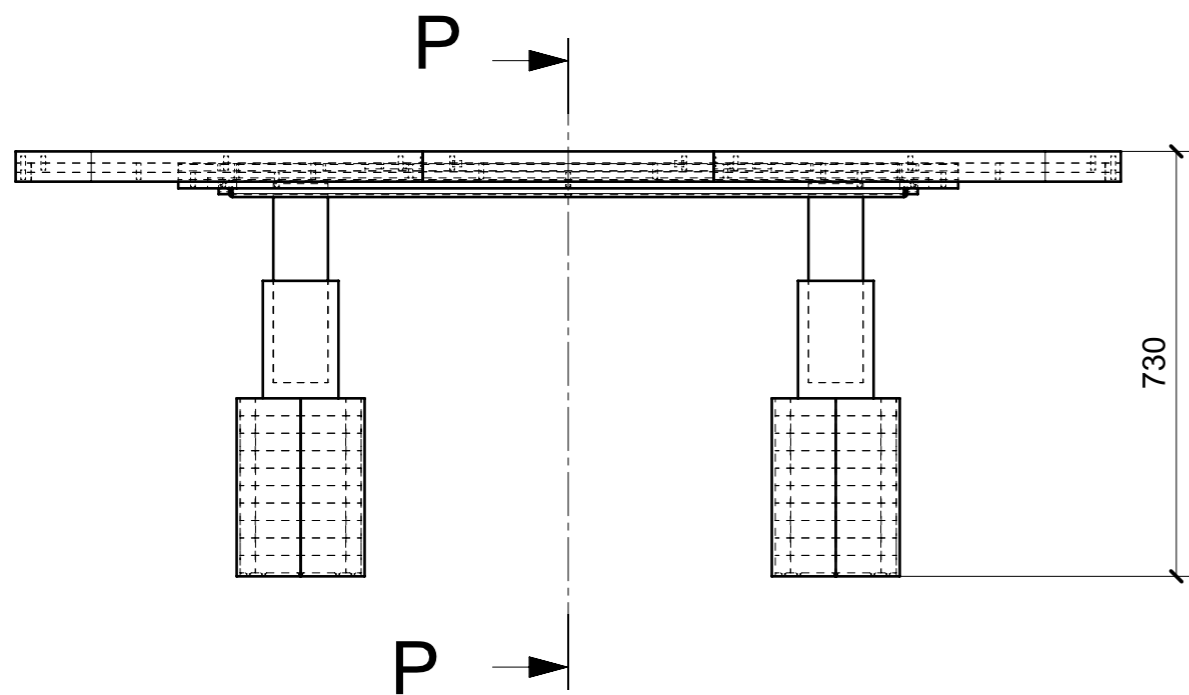

LOCALE	CODICE	DESCRIZIONE COMPONENTE	FINITURA	Q.TA
SALONE	MD299_MF_SSD01	COFFE TABLE OPT		1

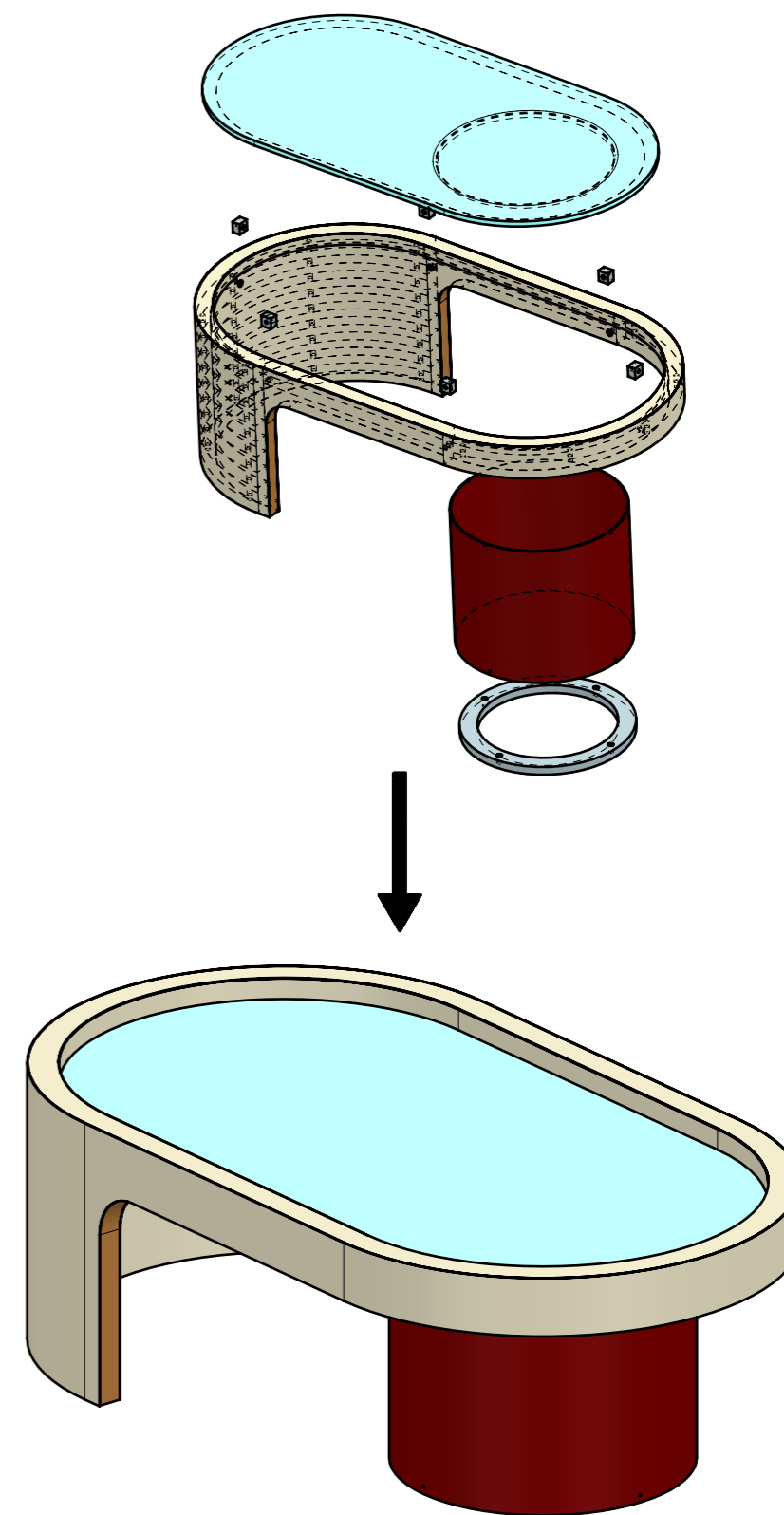
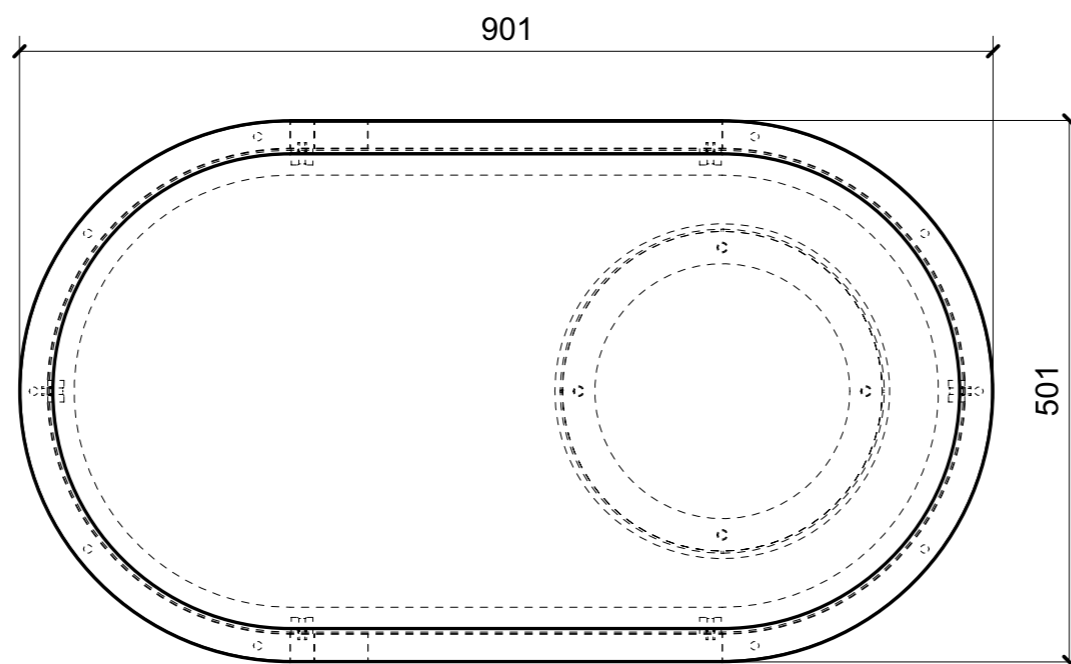
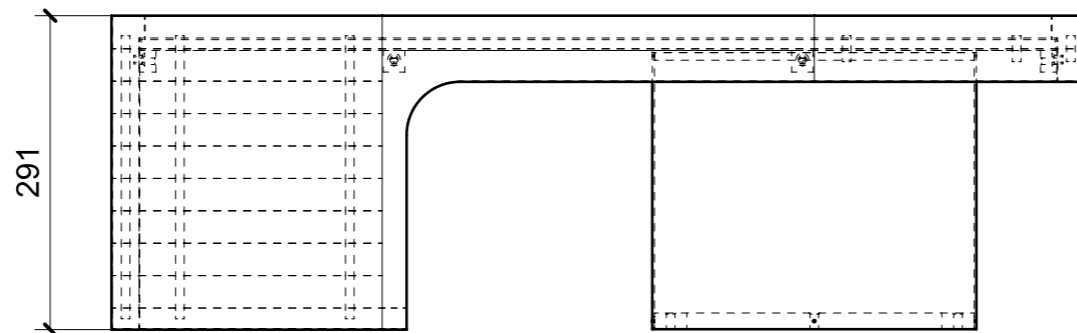
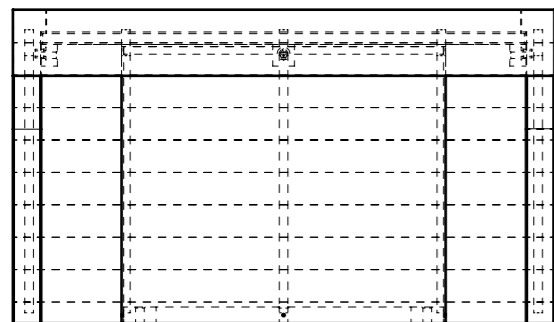

FERRAMENTA	QTY
BUSSOLA 5MA X 10 FORO DIAM.8	6