

LOCALE	CODICE	DESCRIZIONE COMPONENTE	FINITURA	Q.TA
CUCINA APERTA	MD299_KA01	BASE LAVASTOVIGLIE	LAMINATO	1

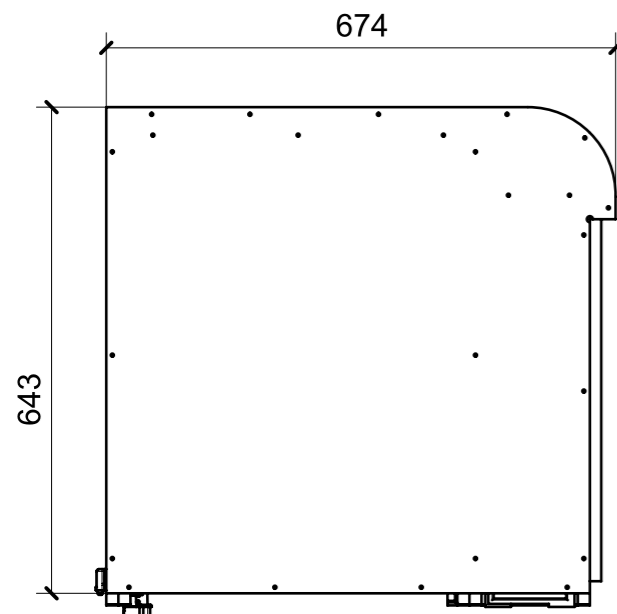

01

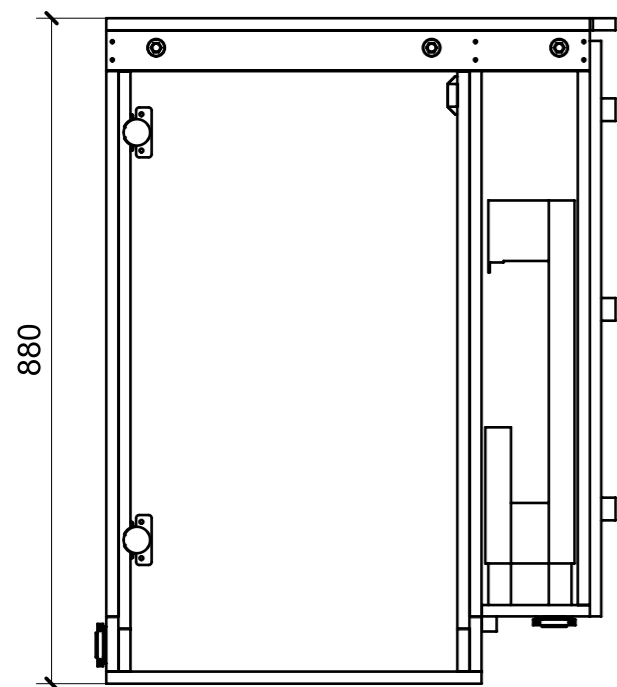
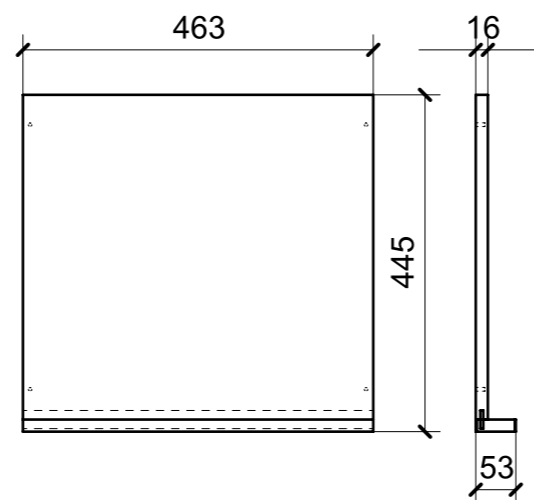

02

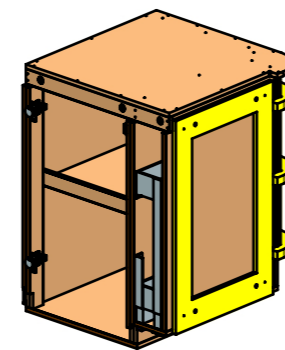

ELEMENTI DA MONTARE
IN MG_KA01
e spedire con unico imballo

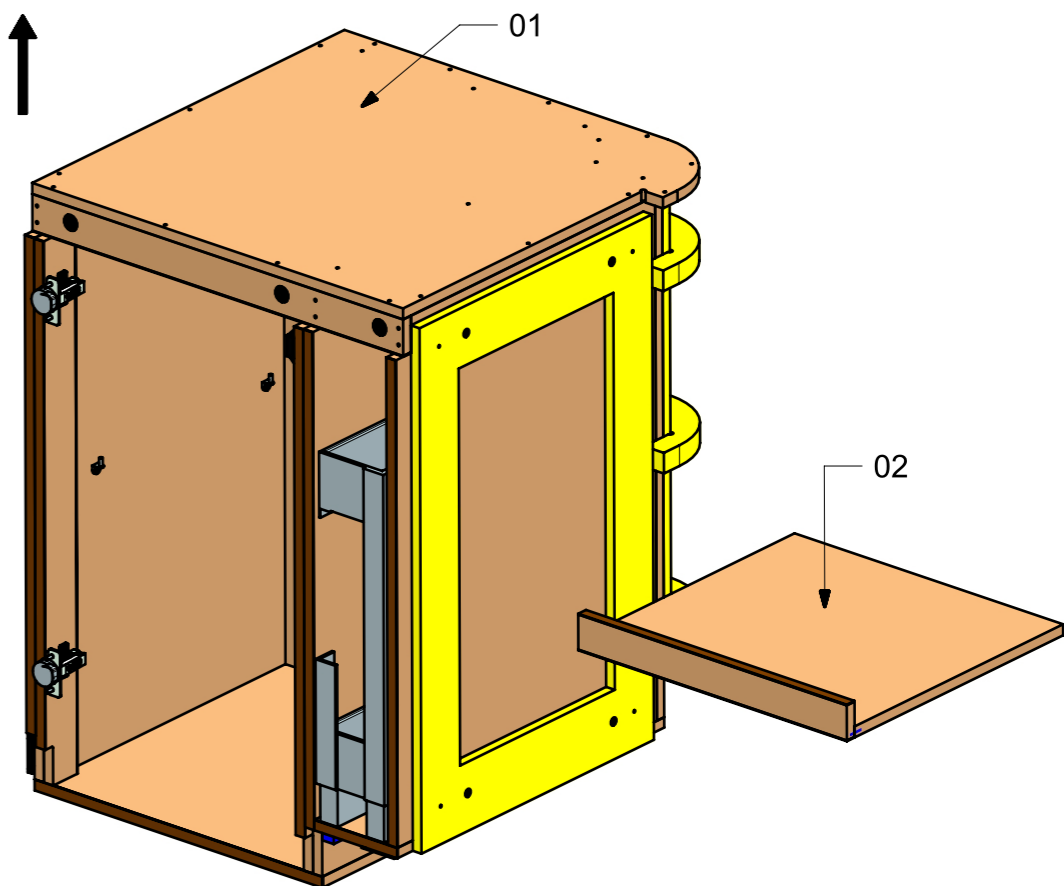

FERRAMENTA	QTY
BASE_6_HAFELE_329_84_026	2
BUSSOLA 5MA ANKOR BORGHI X CERNIERA PIANA	4
BUSSOLA 6MA X 10 FORO DIAM.8	9
CALAMITA SEALED MAGNETIC_TECNOPARTNER_MC-JM50-BL	1
CERNIERA 94° PIANA AMMORTIZZATA_HAFELE_329_49_310	2
CESTELLO ESTRAIBILILE NEW LINE 4799-15_FBC_00443678	1
CHIUSURA A SPINTA_TECNOPARTNER_SOU C3-203	2
FM INCASSO_ITALVIPLA_973_FMPC_F1A	3
REGGRIPIANO 1PERNO 1FORO_FBC_00257770	4
VITE 4MAX8 ANKOR BORGHI X CERNIERA PIANA	4

LOCALE	CODICE	DESCRIZIONE COMPONENTE	FINITURA	Q.TA
CUCINA APERTA	MD299_KB01	MURETTO DIVISORIO BASE ANGOLO_STD VAR 1	OKUME' GREZZO	1

ELEMENTO DA MONTARE CON A32_KB01_01 IN MF_KB01
e spedire con unico imballo

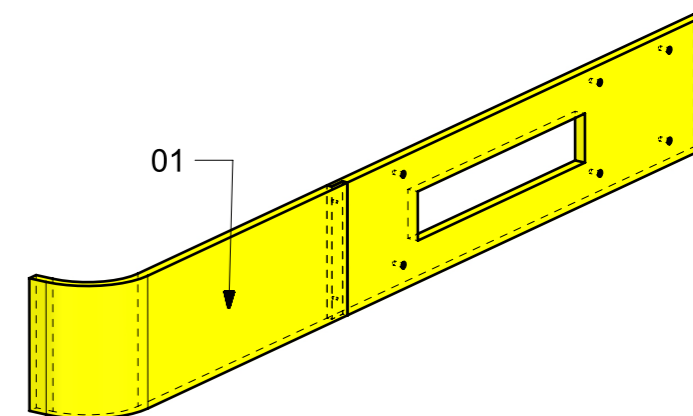
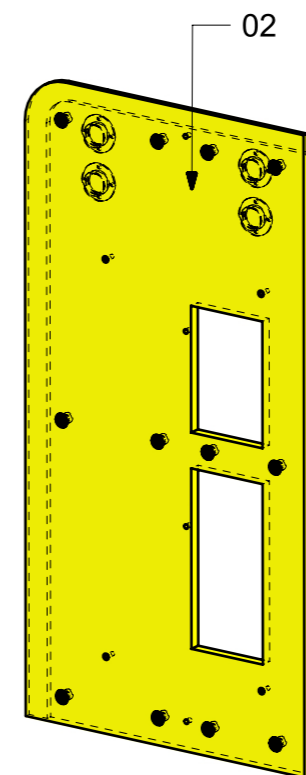
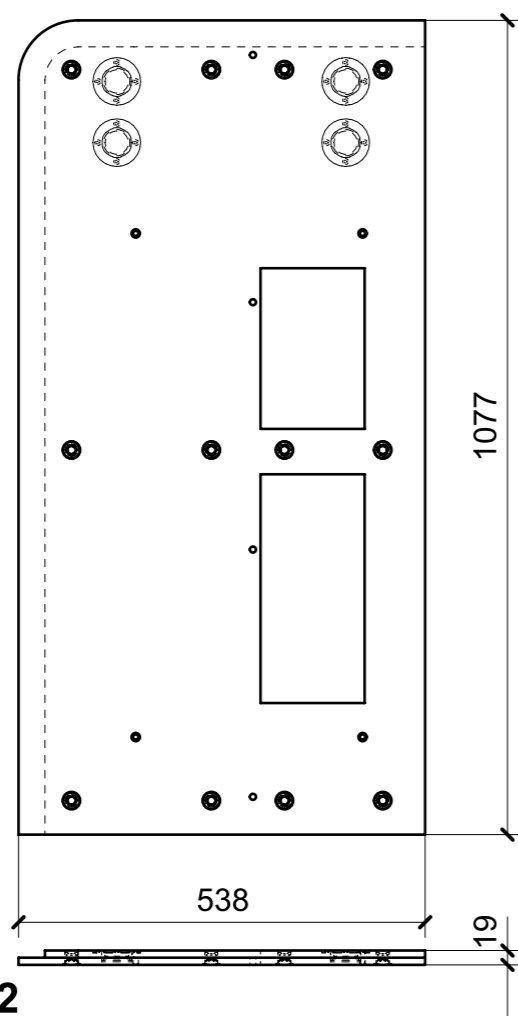
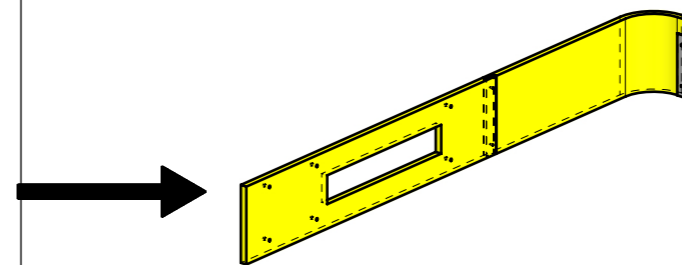
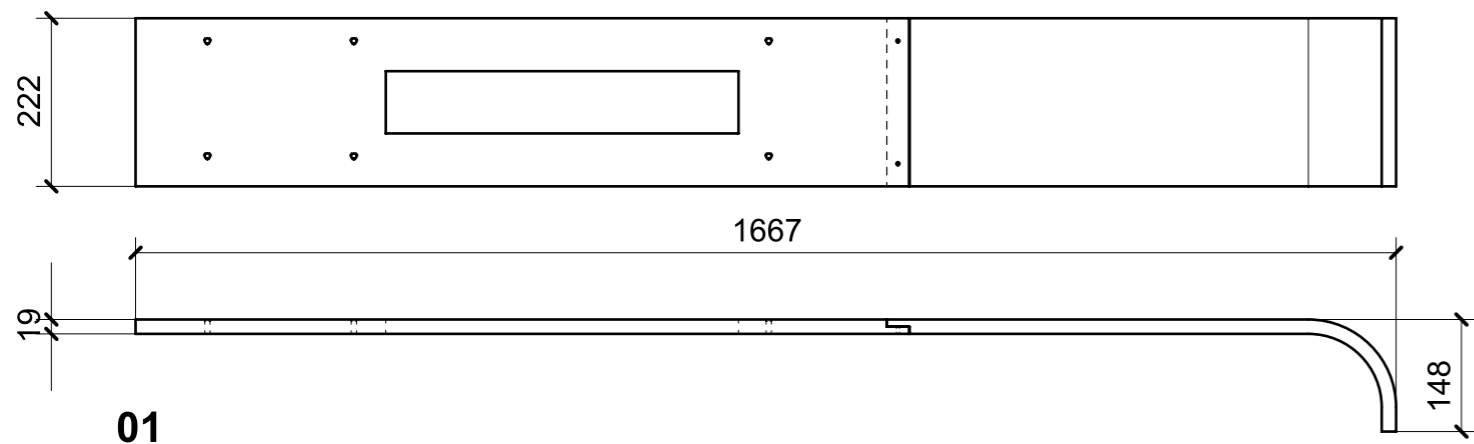

FERRAMENTA	QTY
FM INCASSO_ITALVIPLA_973_FMPC_F1A	12
FITLOCK F_MASCHERPA_6020101102	4

LOCALE	CODICE	DESCRIZIONE COMPONENTE	FINITURA	Q.TA
CUCINA CHIUSA	MD299_KKB01	MURETTO DIVISORIO BASE ANGOLO_STD VAR 2	OKUME' GREZZO	1

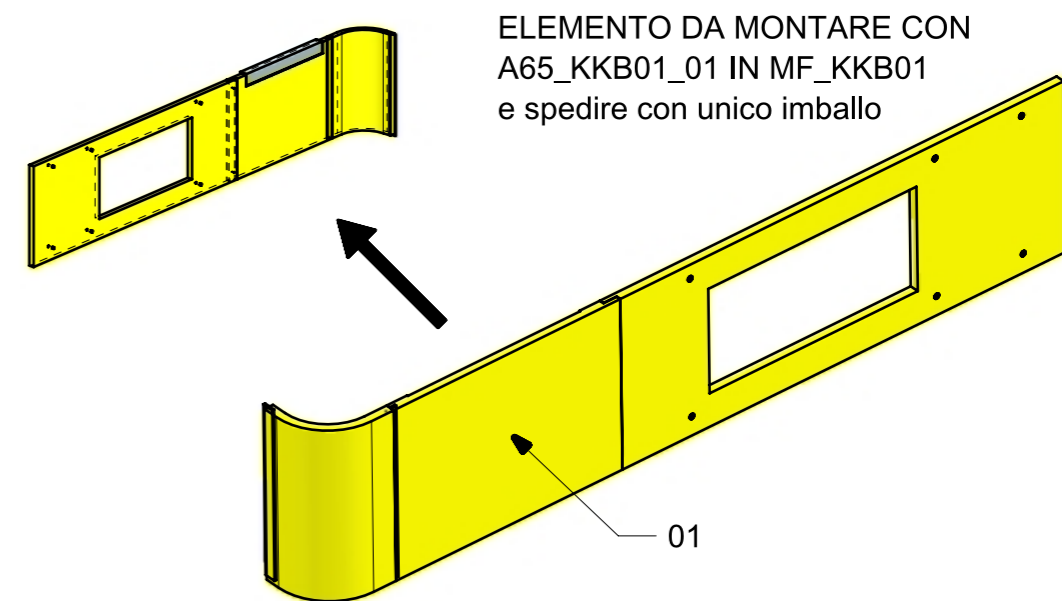
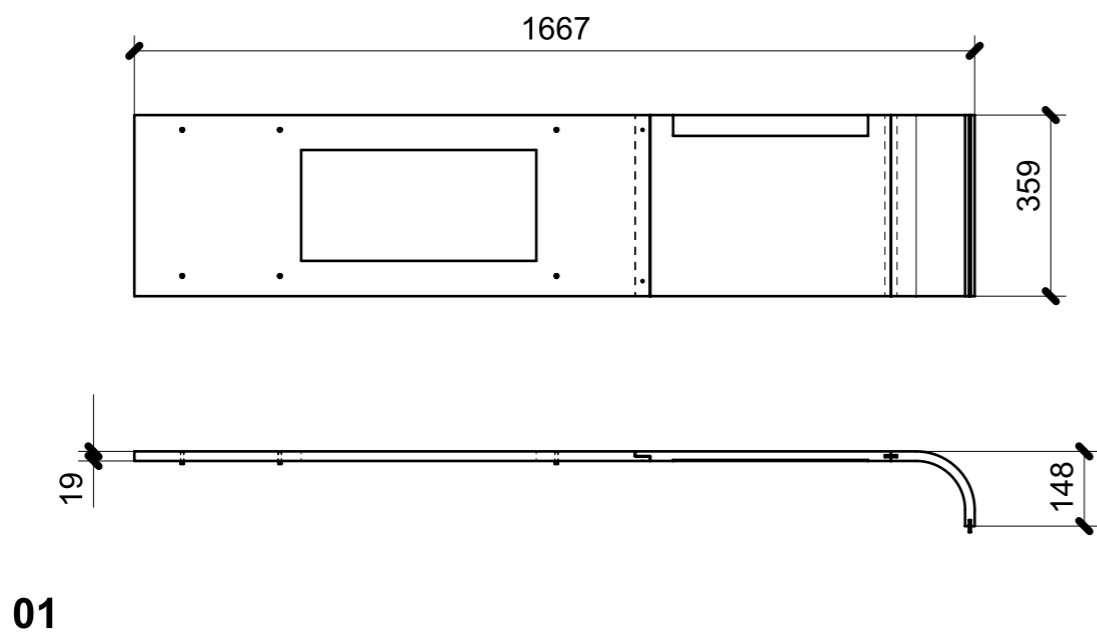

FERRAMENTA	QTY
MD299_A65_KKB01_01	1
VITE 6MA X 25 TESTA SVASATA	6

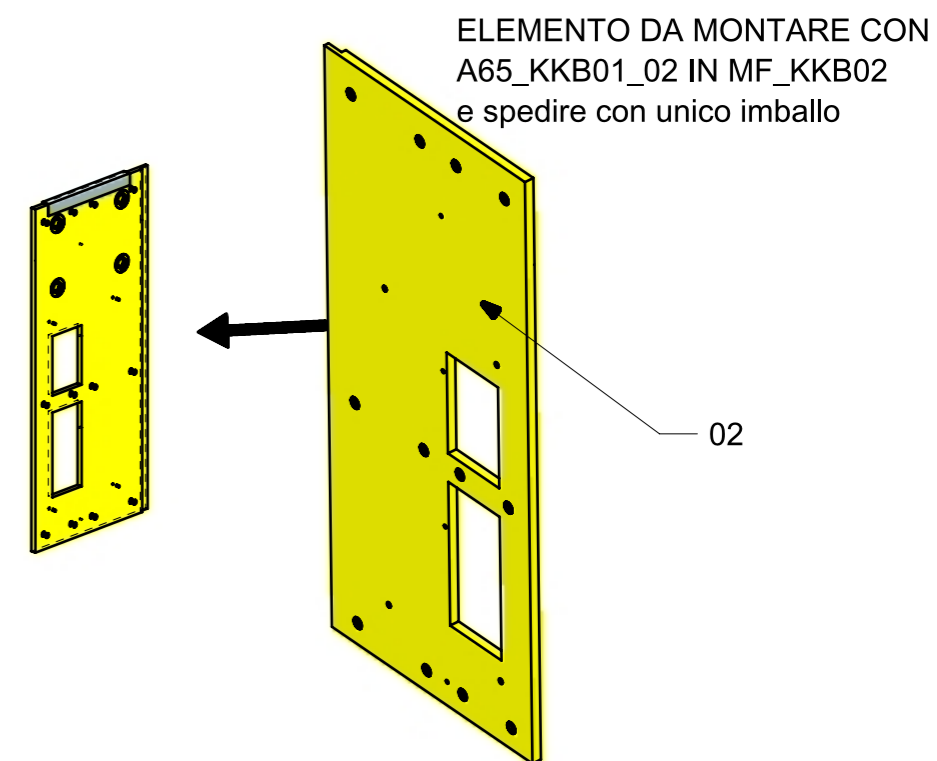
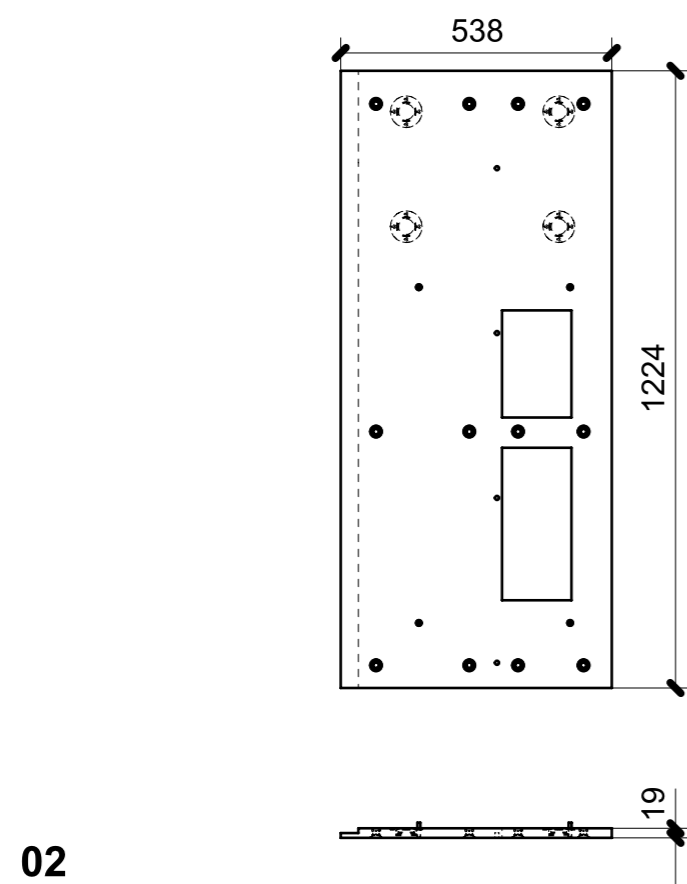

FERRAMENTA	QTY
MD299_A65_KKB01_02	1
FITLOCK F_MASCHERPA_6020101102	4
FM INCASSO_ITALVIPLA_973_FMPC_F1A	12
VITE 6MA X 30 TESTA SVASATA	4

LOCALE	CODICE	DESCRIZIONE COMPONENTE	FINITURA	Q.TA
CUCINA APERTA	MD299_KC01	BASE ANGOLO	LAMINATO	1

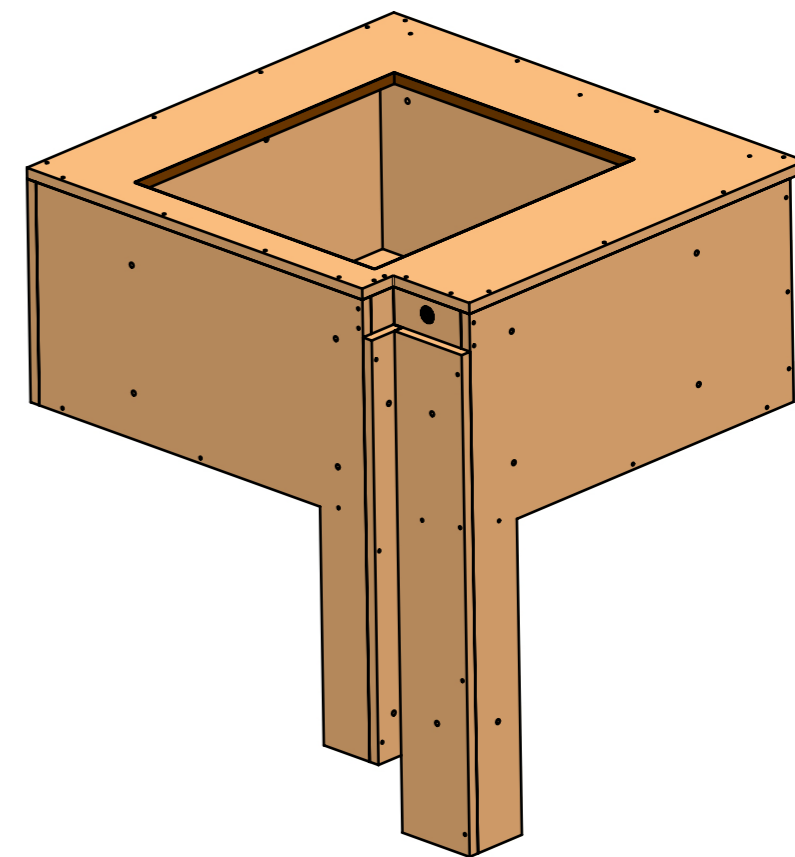
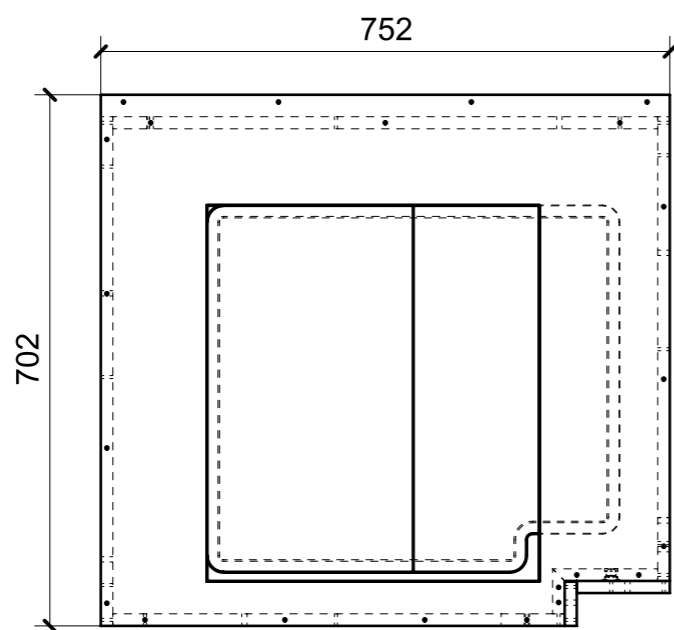
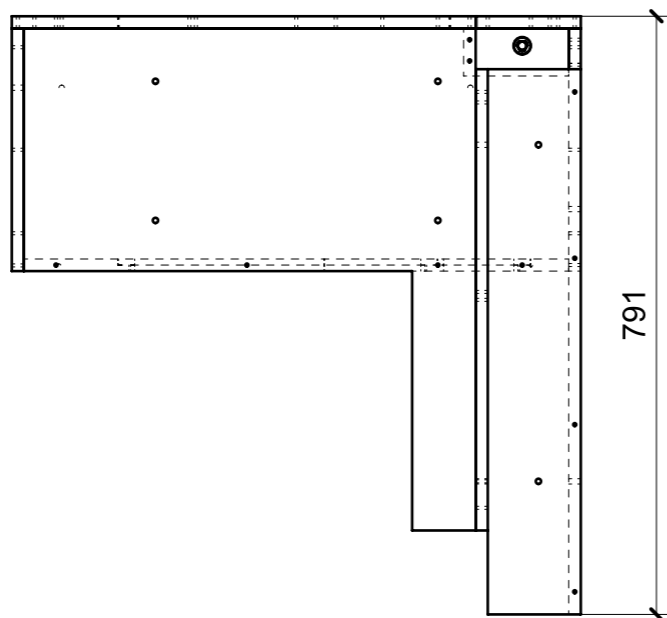

FERRAMENTA	QTY
FM INCASSO_ITALVIPLA_973_FMPC_F1A	1

LOCALE	CODICE	DESCRIZIONE COMPONENTE	FINITURA	Q.TA
CUCINA APERTA	MD299_KD01	BASE LAVELLO E FORNO	LAMINATO/GREZZO	1

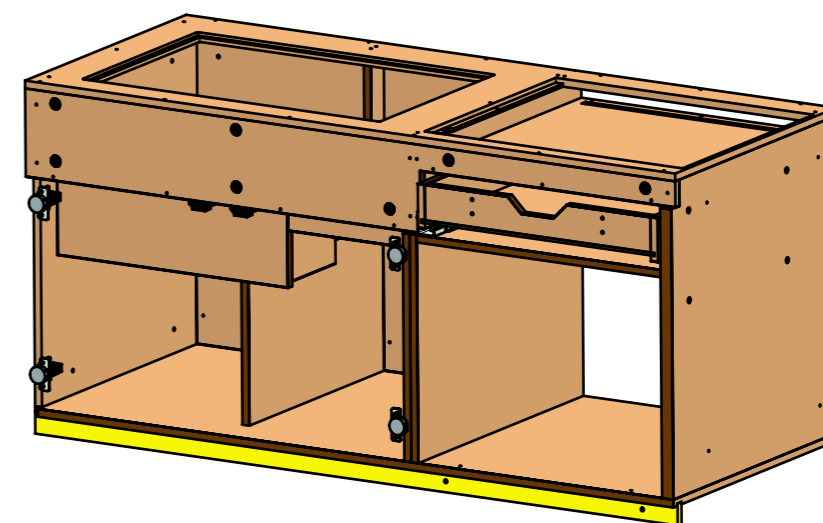
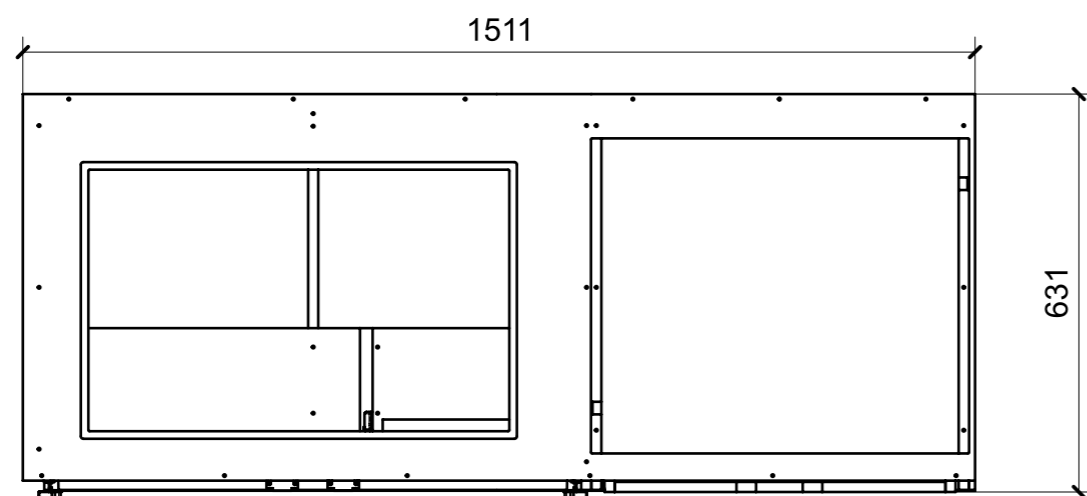
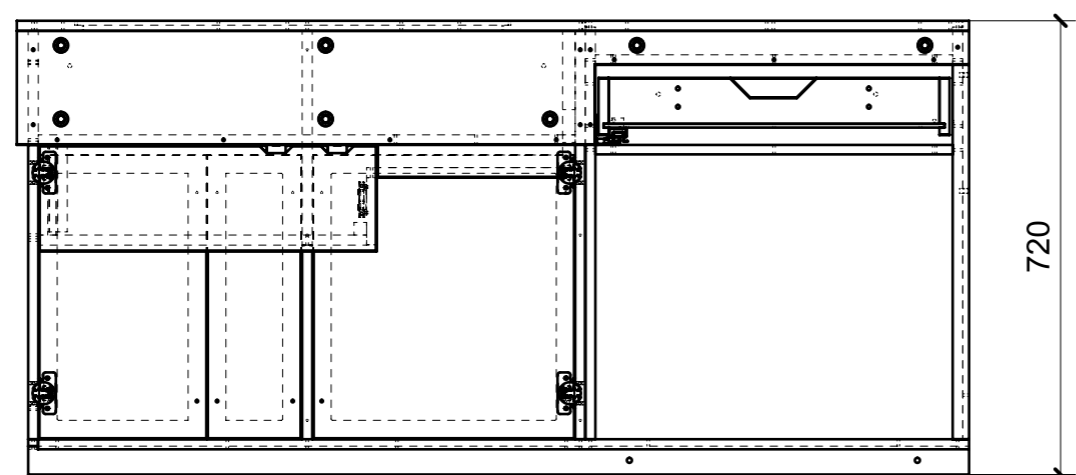

FERRAMENTA	QTY
BASE_6_HAFELE_329_84_026	4
BUSSOLA 5MA ANKOR BORGHI X CERNIERA PIANA	8
BUSSOLA 6MA X 10 FORO DIAM.8	4
CALAMITA SEALED MAGNETIC_TECNOPARTNER_MC-JM50-BL	2
CERNIERA 94° PIANA AMMORTIZZATA_HAFELE_329_49_310	4
CHIUSURA A SPINTA_TECNOPARTNER_SOU C3-203	1
CP GUIDA TANDEMPLUS 550_HAFELE_423_54_755_ESSEPI_00175920	1
FM INCASSO_ITALVIPLA_973_FMPC_F1A	7
VITE 4MAX8 ANKOR BORGHI X CERNIERA PIANA	8

LOCALE	CODICE	DESCRIZIONE COMPONENTE	FINITURA	Q.TA
CUCINA APERTA	MD299_KE01	BASE FRIGO	LAMINATO/GREZZO	1

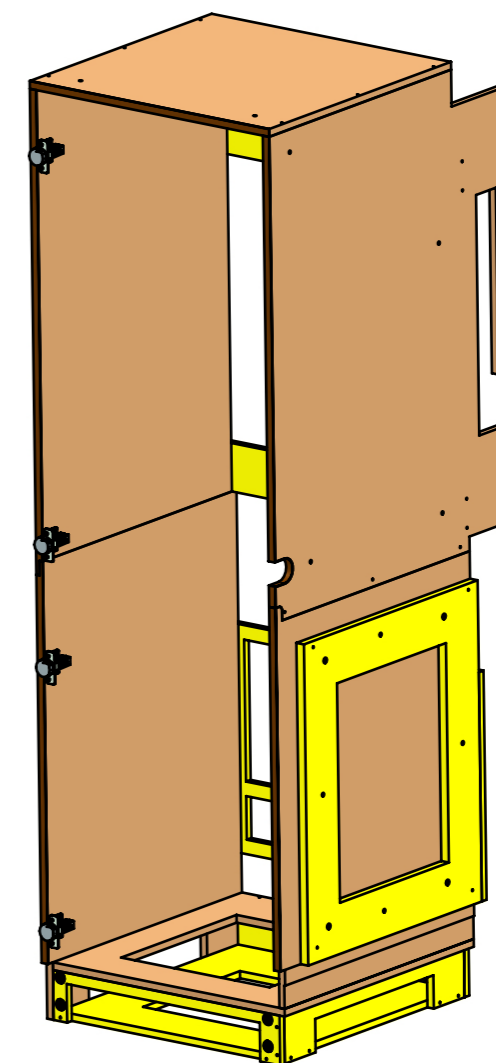
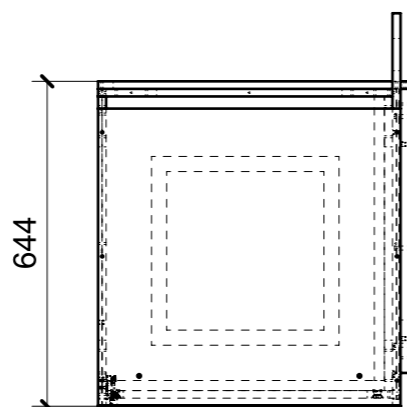
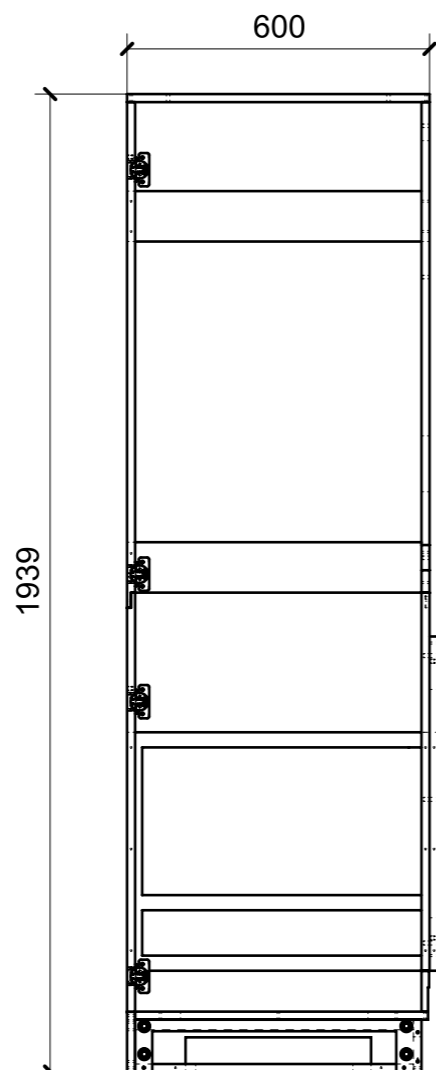
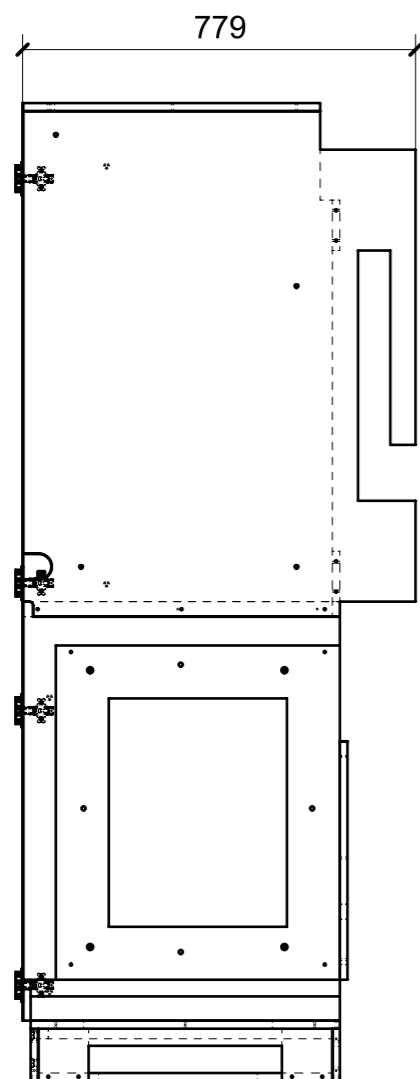

FERRAMENTA	QTY
BASE_6_HAFELE_329_84_026	4
BUSSOLA 5MA ANKOR BORGHI X CERNIERA PIANA	8
BUSSOLA 6MA X 10 FORO DIAM.8	8
CERNIERA 94° PIANA AMMORTIZZATA_HAFELE_329_49_310	4
FM INCASSO_ITALVIPLA_973_FMPC_F1A	4
VITE 4MAX8 ANKOR BORGHI X CERNIERA PIANA	8

LOCALE	CODICE	DESCRIZIONE COMPONENTE	FINITURA	Q.TA
CUCINA APERTA	MD299_KF01	FIANCO FRIGO A POPPA	LAMINATO/GREZZO	1

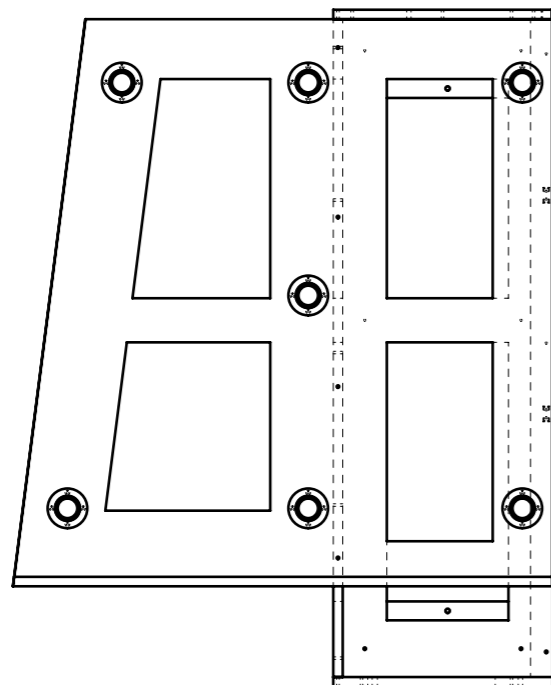
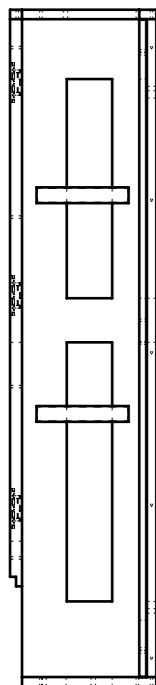

01

FERRAMENTA	QTY
FITLOCK F_MASCHERPA_6020101102	7

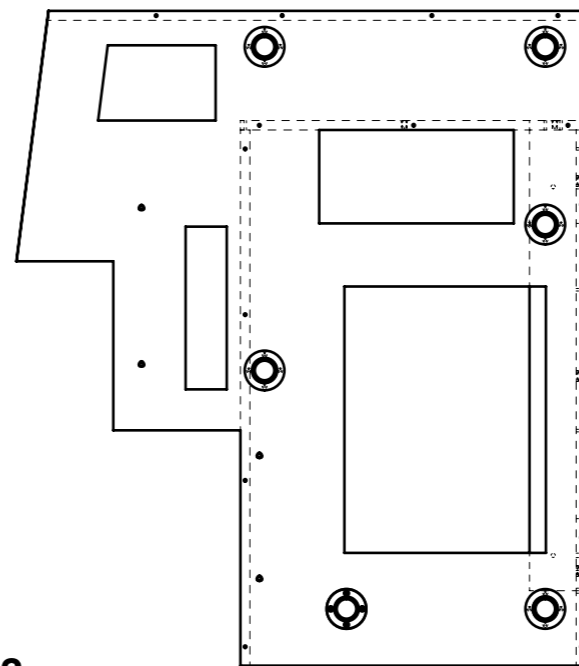
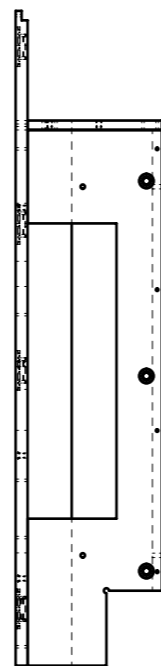
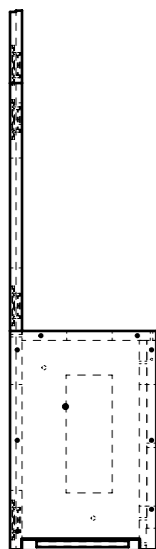

02

FERRAMENTA	QTY
BUSSOLA 6MA X 10 FORO DIAM.8	6
FITLOCK F_MASCHERPA_6020101102	6
FM INCASSO_ITALVIPLA_973_FMPC_F1A	3

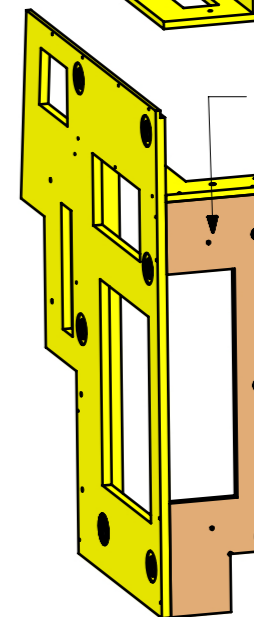
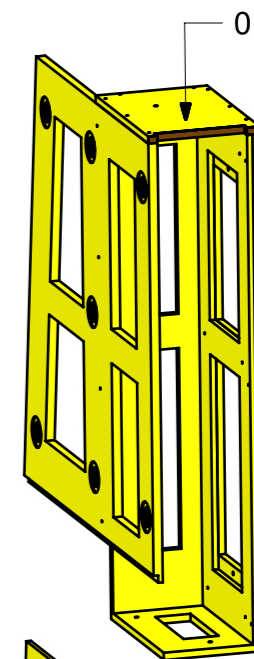
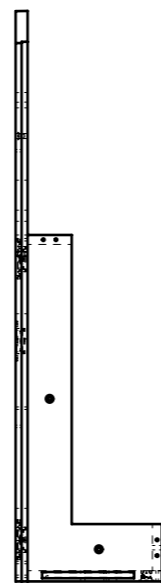

LOCALE	CODICE	DESCRIZIONE COMPONENTE	FINITURA	Q.TA
CUCINA APERTA	MD299_KG01	BASE CUCINA DINING	LAMINATO\ GREZZO	1

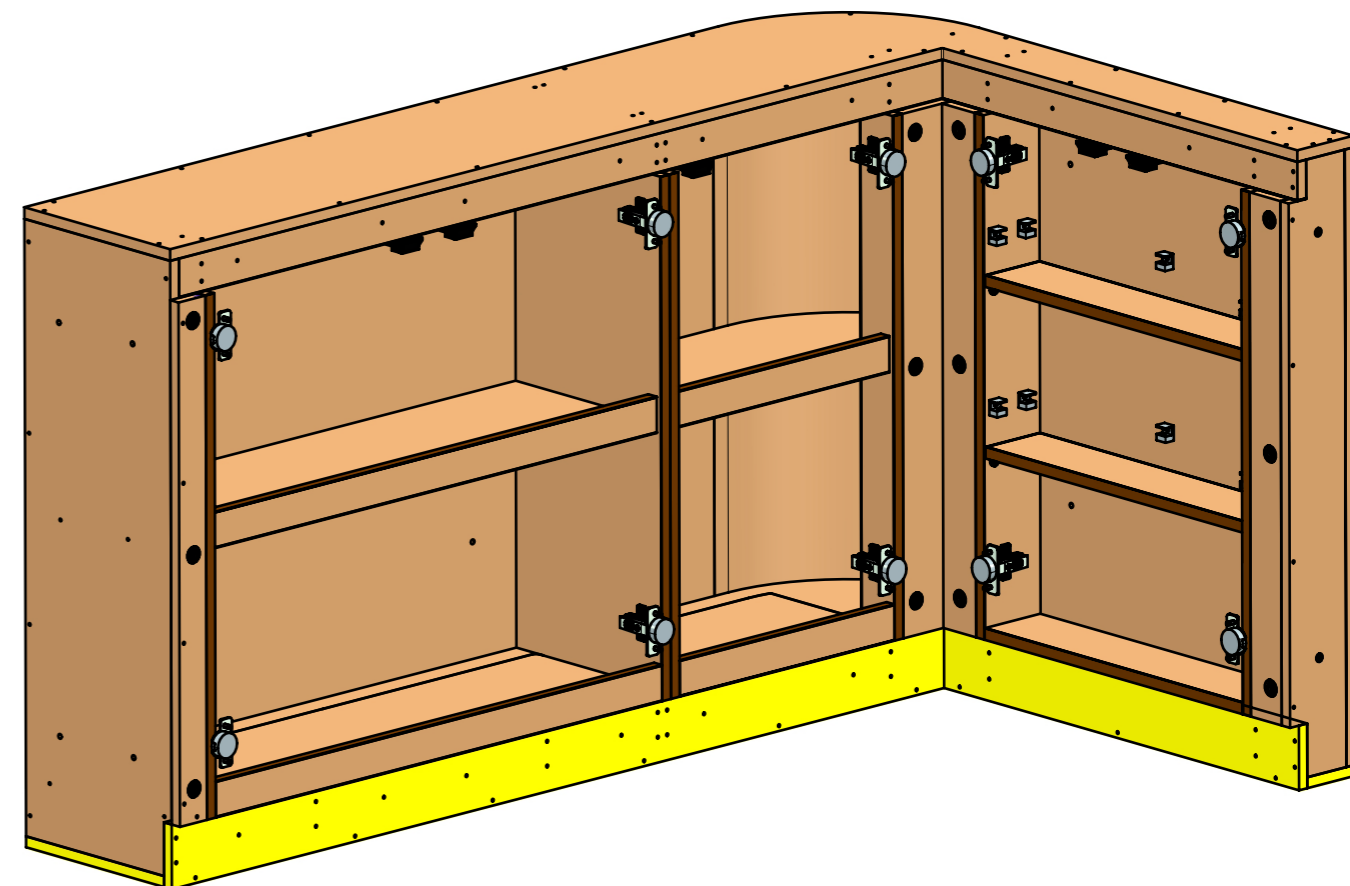
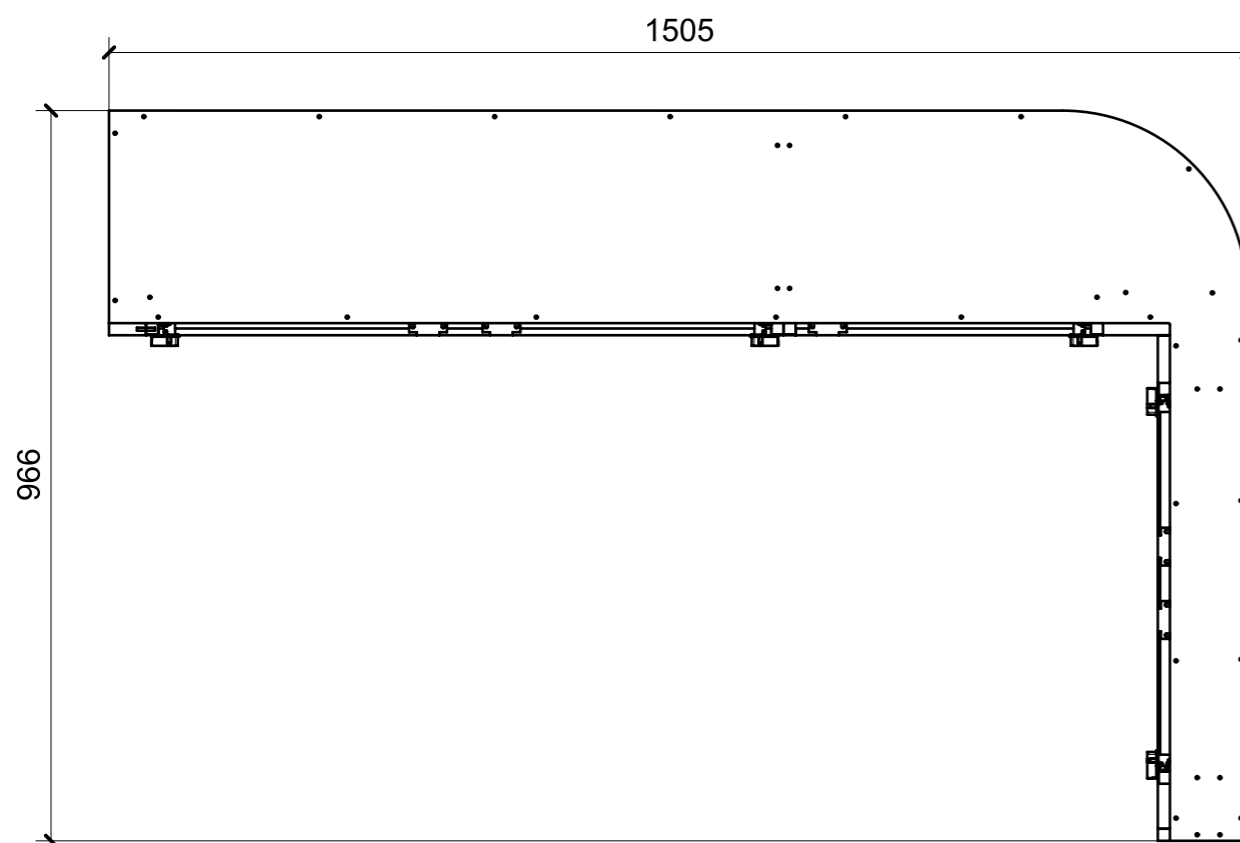
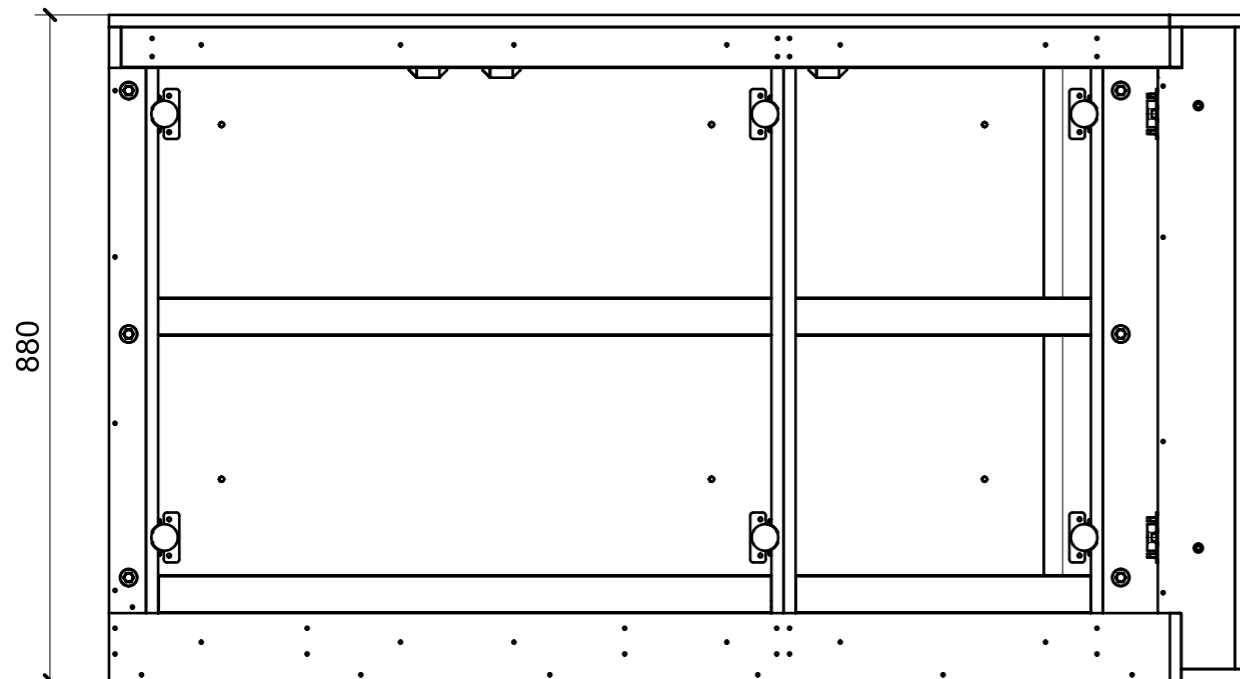

FERRAMENTA	QTY
BASE_6_HAFELE_329_84_026	10
BUSSOLA 5MA ANKOR BORGHI X CERNIERA PIANA	40
BUSSOLA 6MA X 10 FORO DIAM.8	2
CALAMITA SEALED MAGNETIC_TECNOPARTNER_MC-JM50-BL	5
CERNIERA 94° PIANA AMMORTIZZATA_HAFELE_329_49_310	10
FM INCASSO_ITALVIPLA_973_FMPC_F1A	12
REGGIRIPIANO QUADRO MM.10 X PLEX_ESSEPI_00171267	10
REGGIRIPIANO 1PERNO 1FORO_FBC_00257770	10
VITE 4MAX8 ANKOR BORGHI X CERNIERA PIANA	20

LOCALE	CODICE	DESCRIZIONE COMPONENTE	FINITURA	Q.TA
CUCINA CHIUSA	MD299_KKH01	RIVESTIMENTO LAMELLE BASE DINING_STD VAR 2	OKUME' GREZZO	1

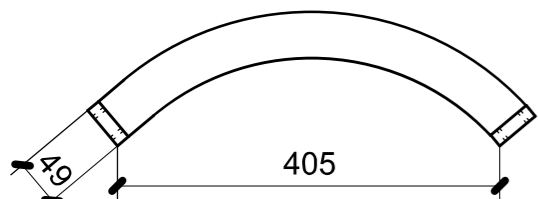
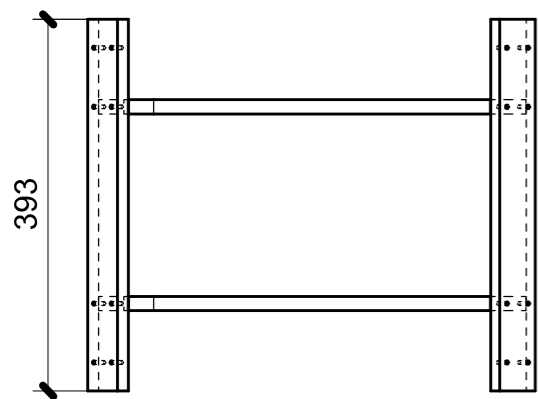

02

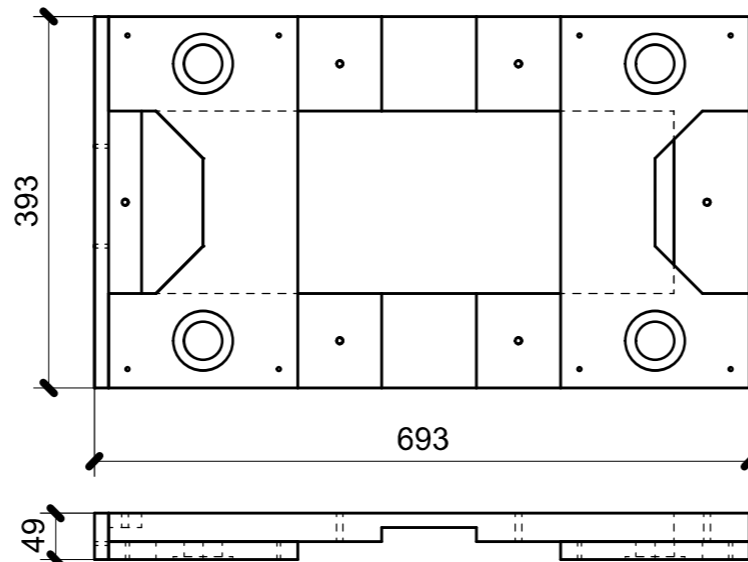

03

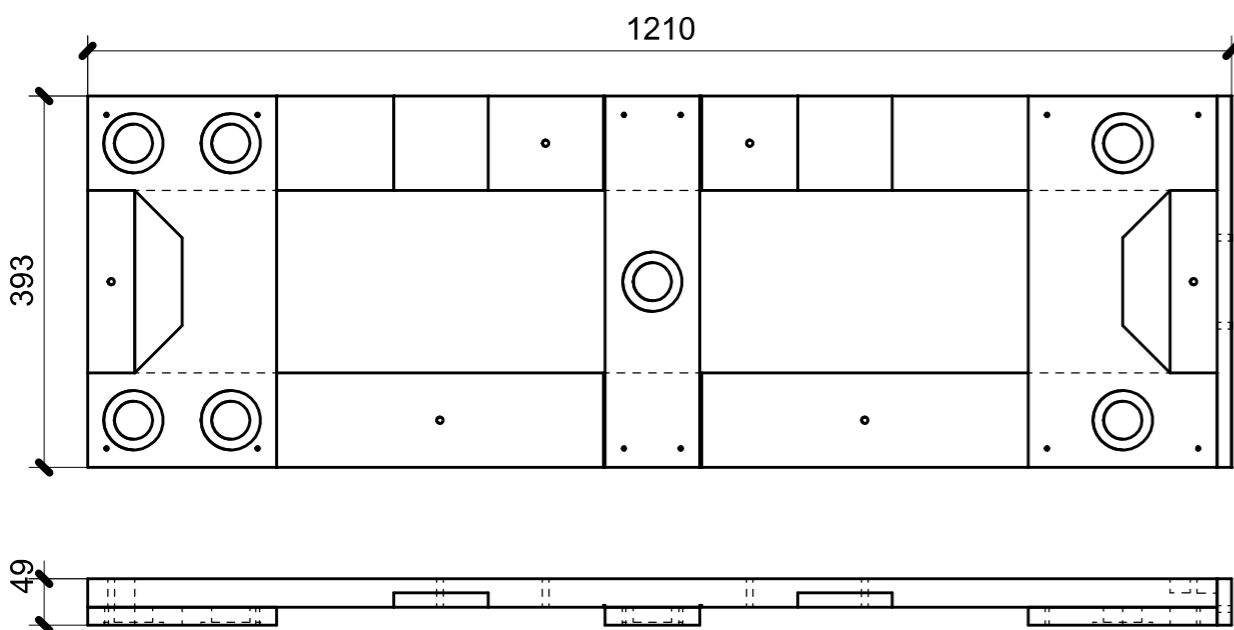

01

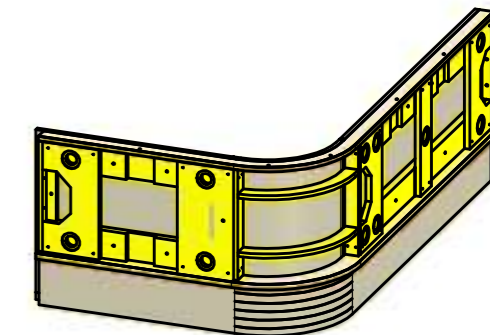

ELEMENTI DA MONTARE CON R01_KKH01_01/06
IN MF_KKH01
e spedire con unico imballo

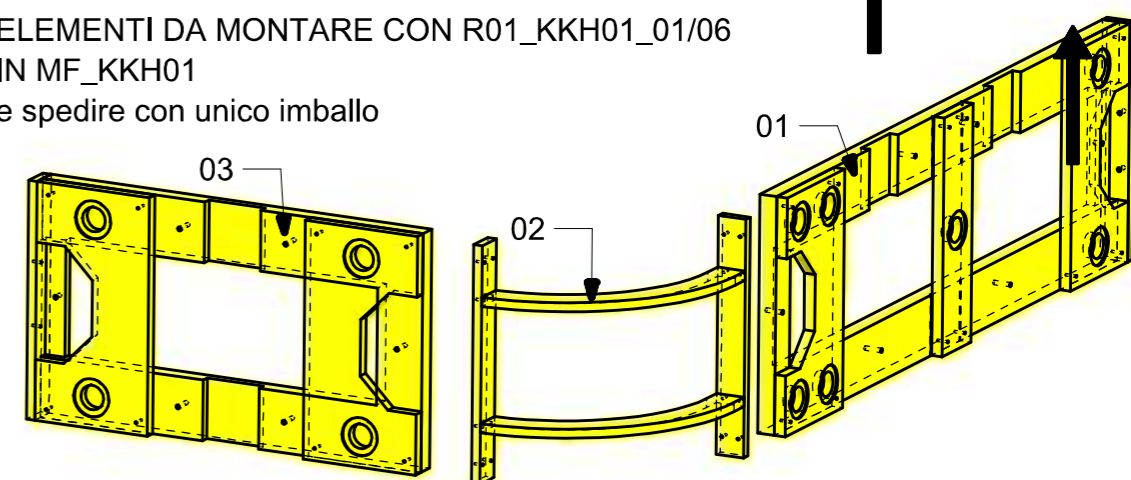

LOCALE	CODICE	DESCRIZIONE COMPONENTE	FINITURA	Q.TA
CUCINA APERTA	MD299_KI01	PENSILE	LAMINATO/GREZZO	1

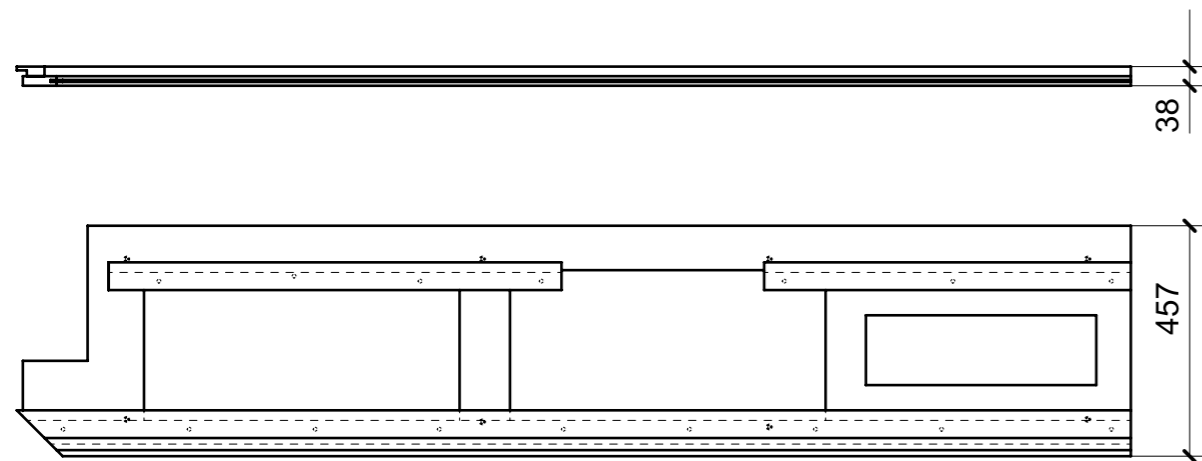

02	FERRAMENTA	QTY
	BUSSOLA 6MA X 10 FORO DIAM.8	8

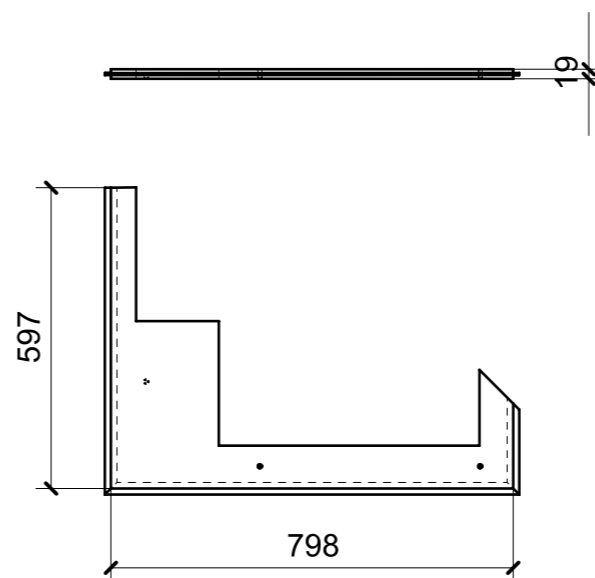

03	FERRAMENTA	QTY
	BUSSOLA 6MA X 10 FORO DIAM.8	3

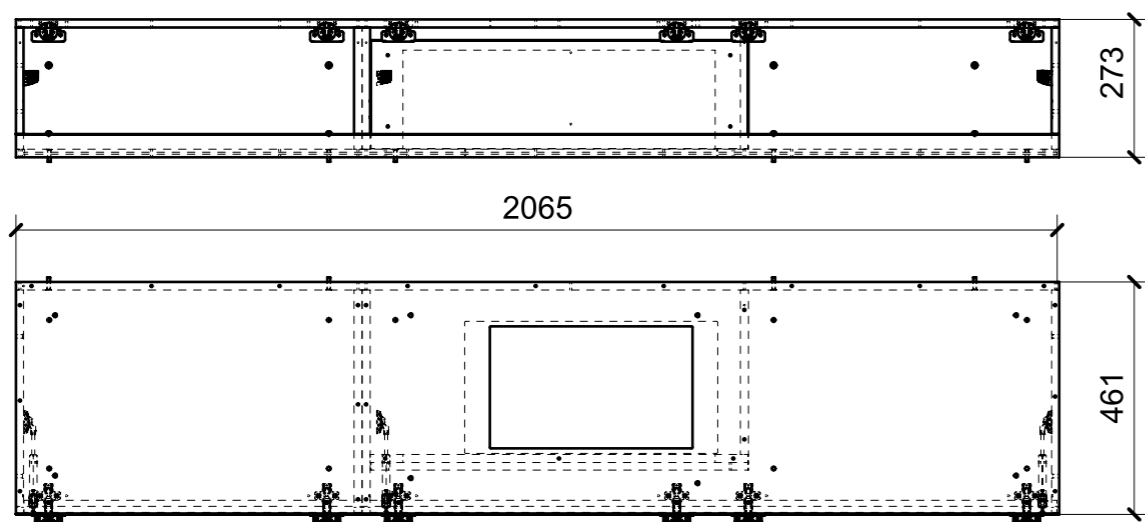
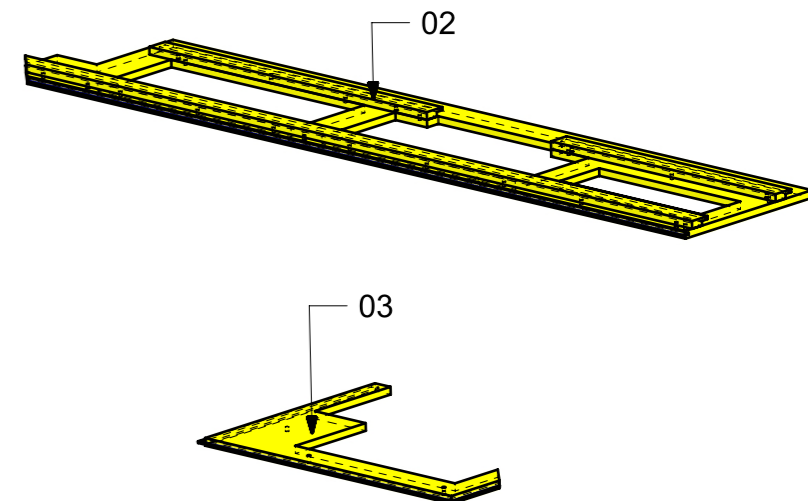

01	FERRAMENTA	QTY
	ASTA DI SOSTEGNO COMPACT CON FRIZIONE MM164 45N LIVENZA_ESSEPI_00178914	3
	BASE_6_HAFELE_329_84_026	6
	BUSSOLA 5MA ANKOR BORGHI X CERNIERA PIANA	12
	CERNIERA 94° PIANA AMMORTIZZATA_HAFELE_329_49_310	6
	SUPPORTO ASTA COMPACT X ANTA_ESSEPI_00133432 X BRACCETTO DA 164	3
	SUPPORTO ASTA COMPACT X FIANCO_ESSEPI_00133449 X BRACCETTO DA 164	3
	VITE 4MAX8 ANKOR BORGHI X CERNIERA PIANA	12
	VITE 6MA X 25 TESTA SVASATA	18

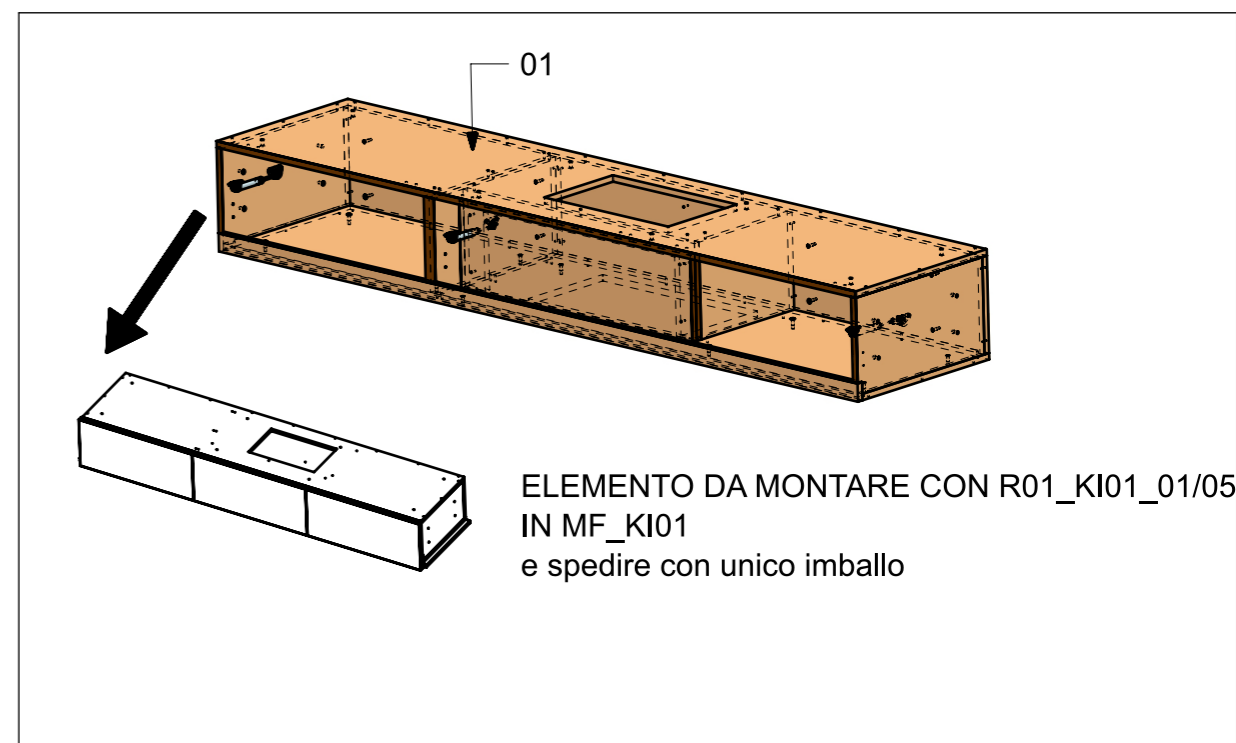

LOCALE	CODICE	DESCRIZIONE COMPONENTE	FINITURA	Q.TA
CUCINA APERTA	MD299_KL01	CONTENITORE A MURATA	LAMINATO	1

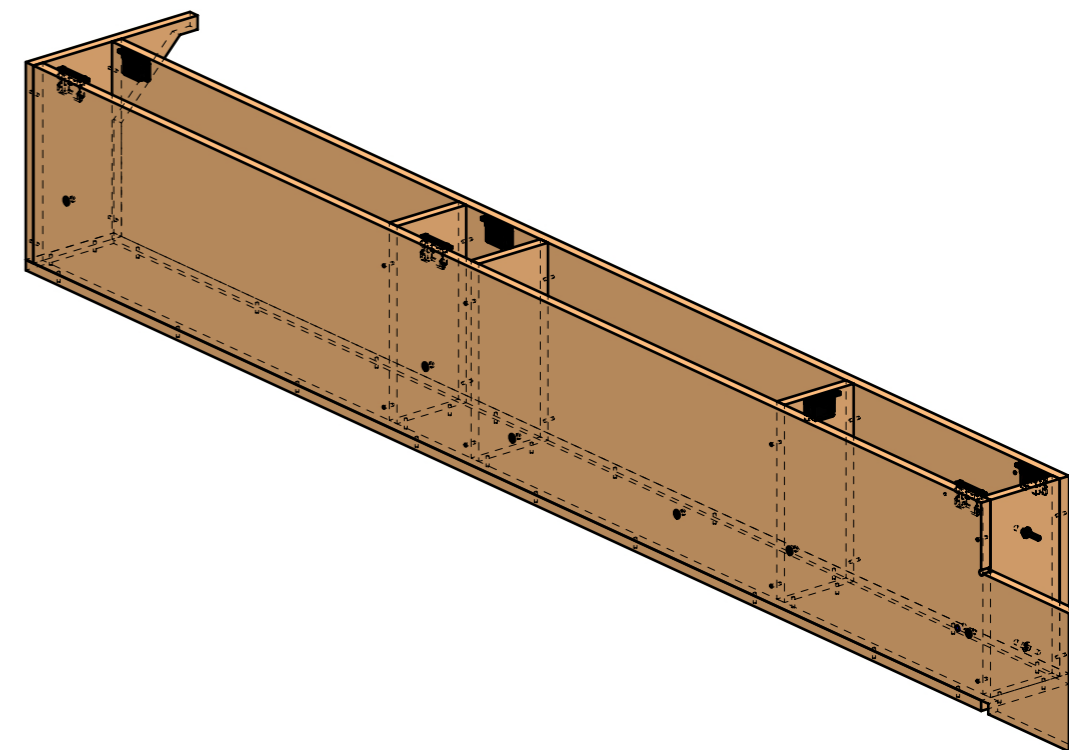
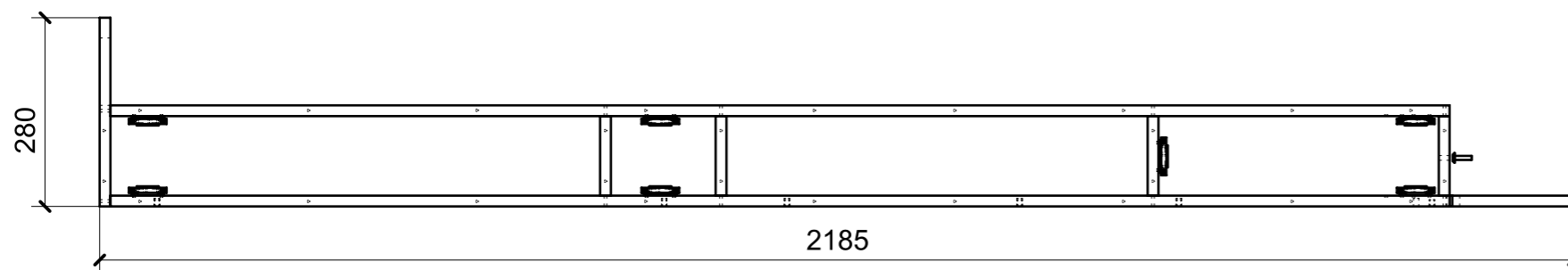
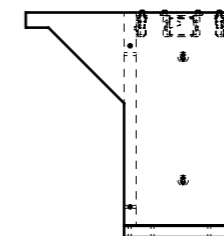
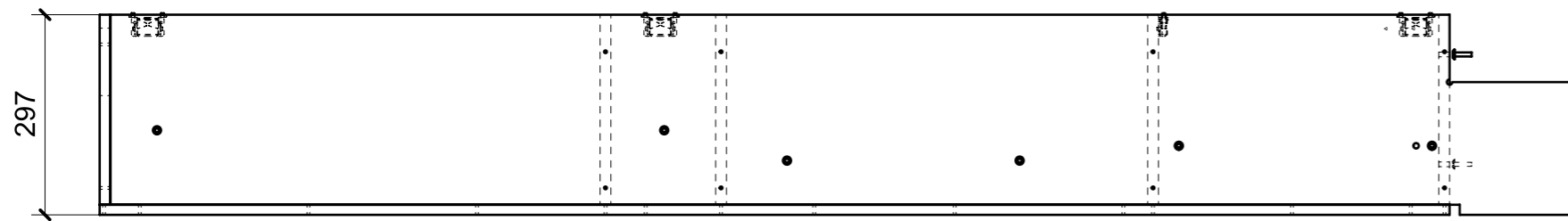

FERRAMENTA	QTY
BUSSOLA 6MA X 10 FORO DIAM.8	6
CHIUSURA A SPINTA_TECHNOPARTNER_SOU C3-203	7
VITE 6MA X 25 TESTA BOMBATA	2

LOCALE	CODICE	DESCRIZIONE COMPONENTE	FINITURA	Q.TA
CUCINA APERTA	MD299_KM01	RIV. COLONNA FINESTRINO	OKUME' GREZZO	1

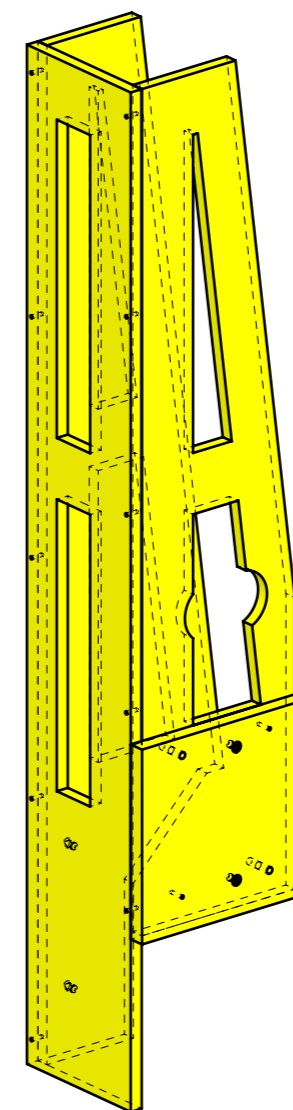
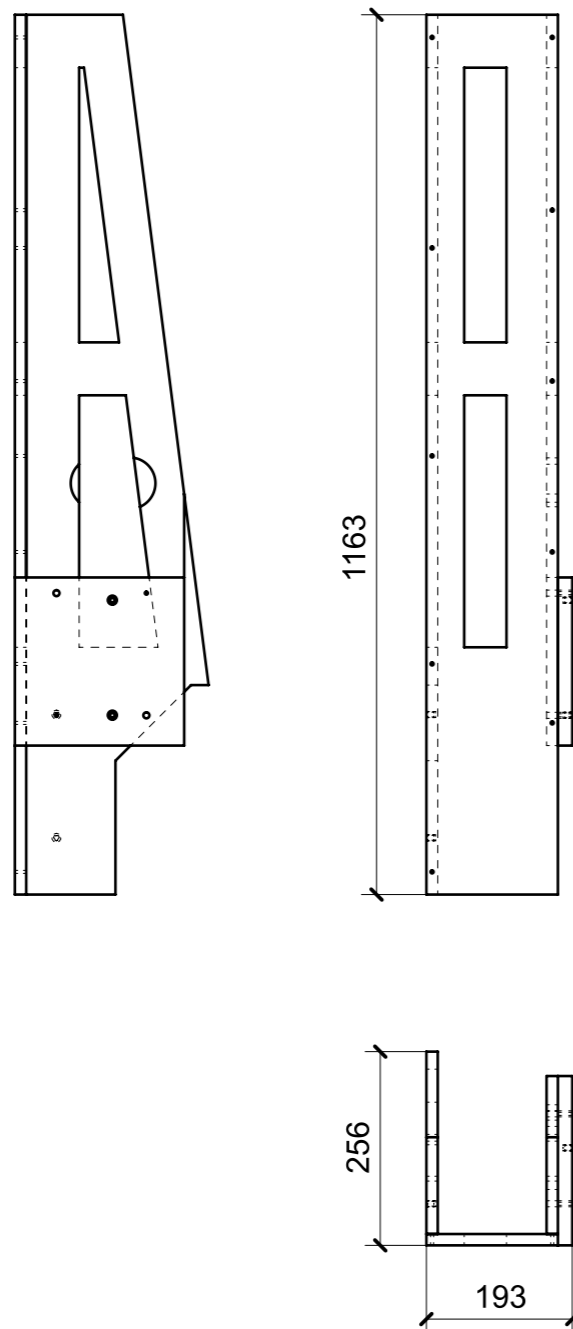

FERRAMENTA	QTY
BUSSOLA 6MAX 10 FORO DIAM.8	4

LOCALE	CODICE	DESCRIZIONE COMPONENTE	FINITURA	Q.TA
CUCINA APERTA	MD299_KKS01	CHIUSURA ALTA PRUA STD VAR 2	OKUME' GREZZO	1

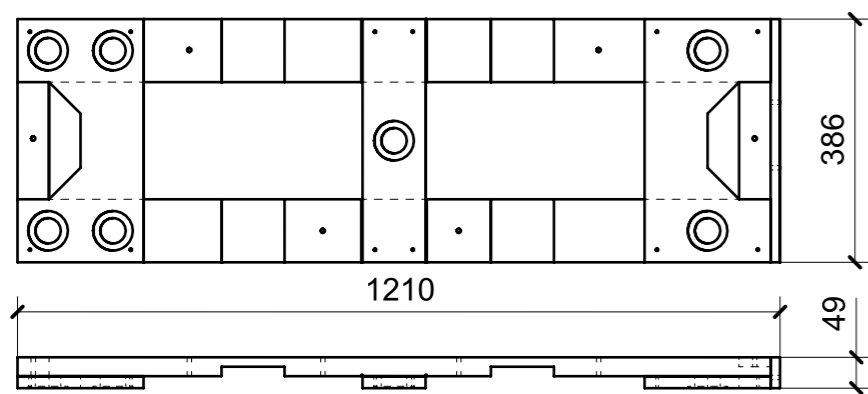

01

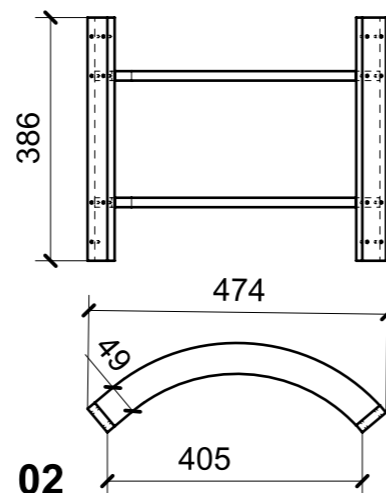

02

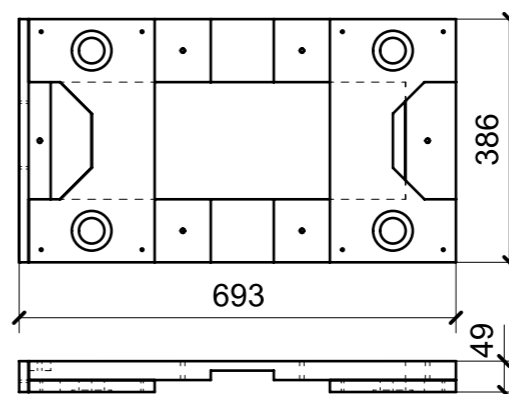

03

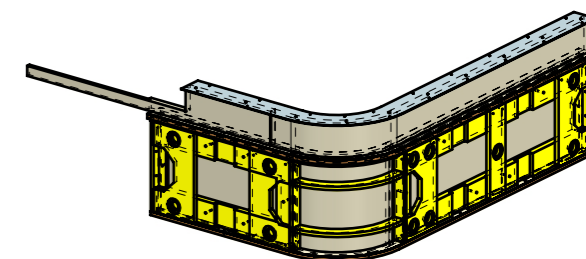

ELEMENTI DA MONTARE CON A67, R01_KKS01_01/08
in MF_KKS01
e spedire con unico imballo

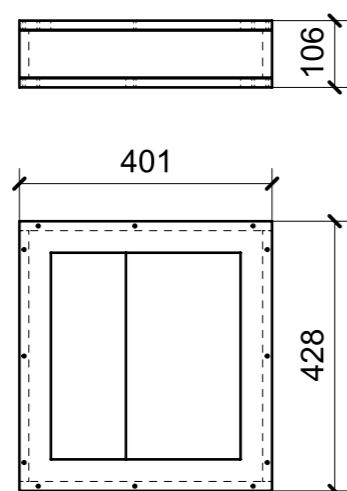

04

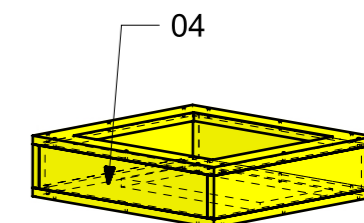
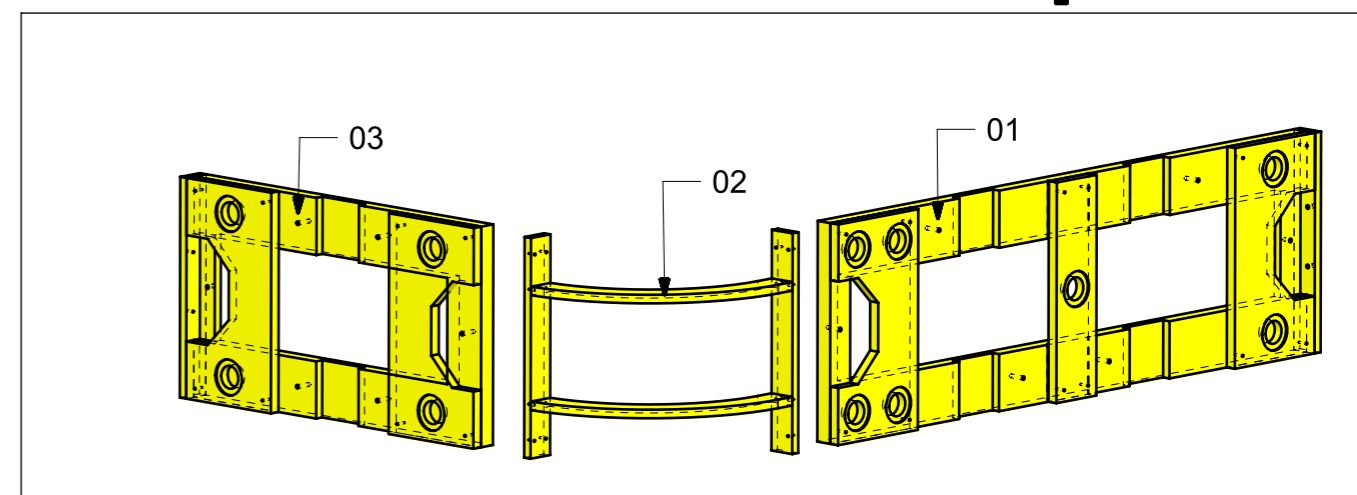

LOCALE	CODICE	DESCRIZIONE COMPONENTE	FINITURA	Q.TA
CUCINA APERTA	MD299_KKT01	CHIUSURA ALTA POPPA_STD VAR 2	OKUME' GREZZO	1

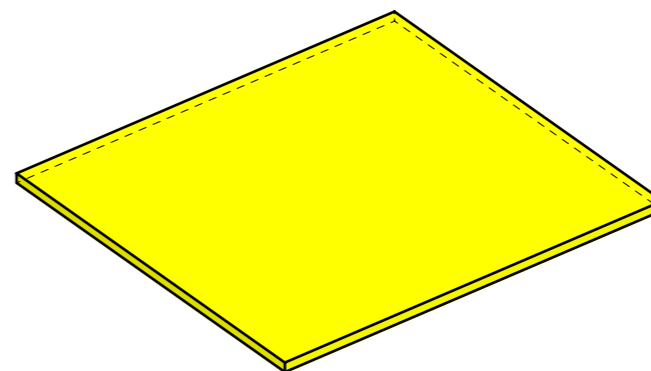
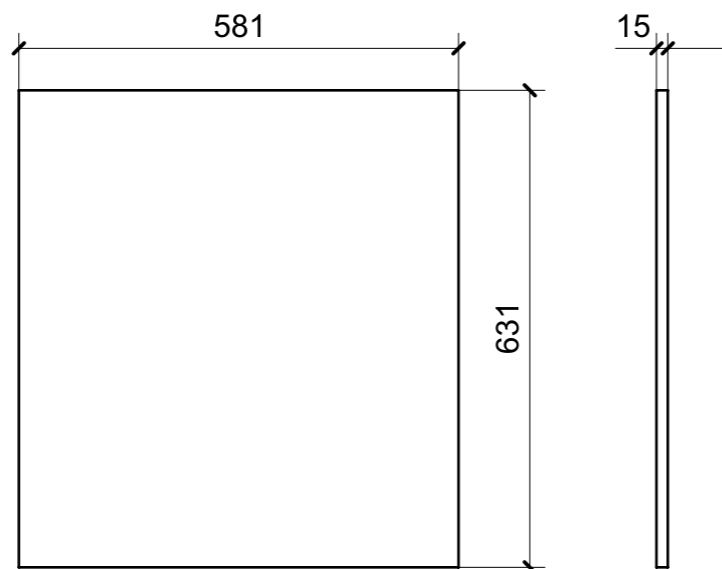

LOCALE	CODICE	DESCRIZIONE COMPONENTE	FINITURA	Q.TA
CUCINA CHIUSA	MD299_KKU01	CIELINO POPPA_STD VAR 2	OKUME' GREZZO	1

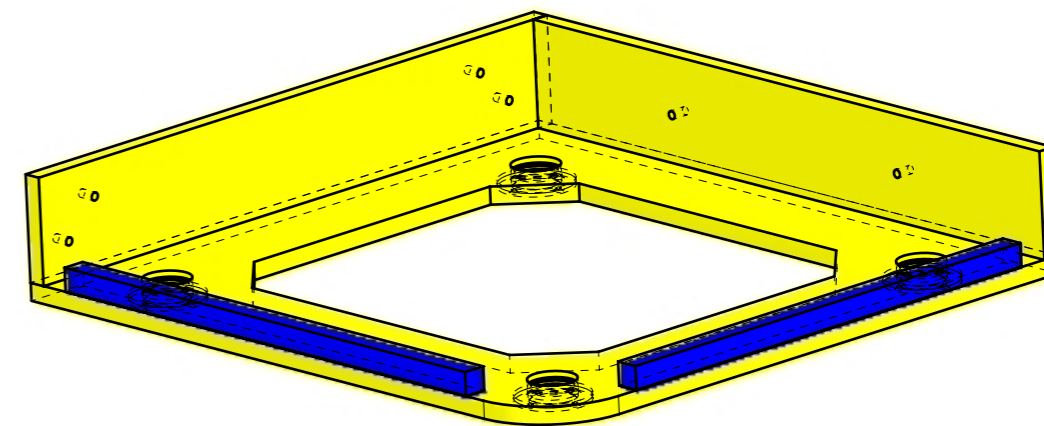
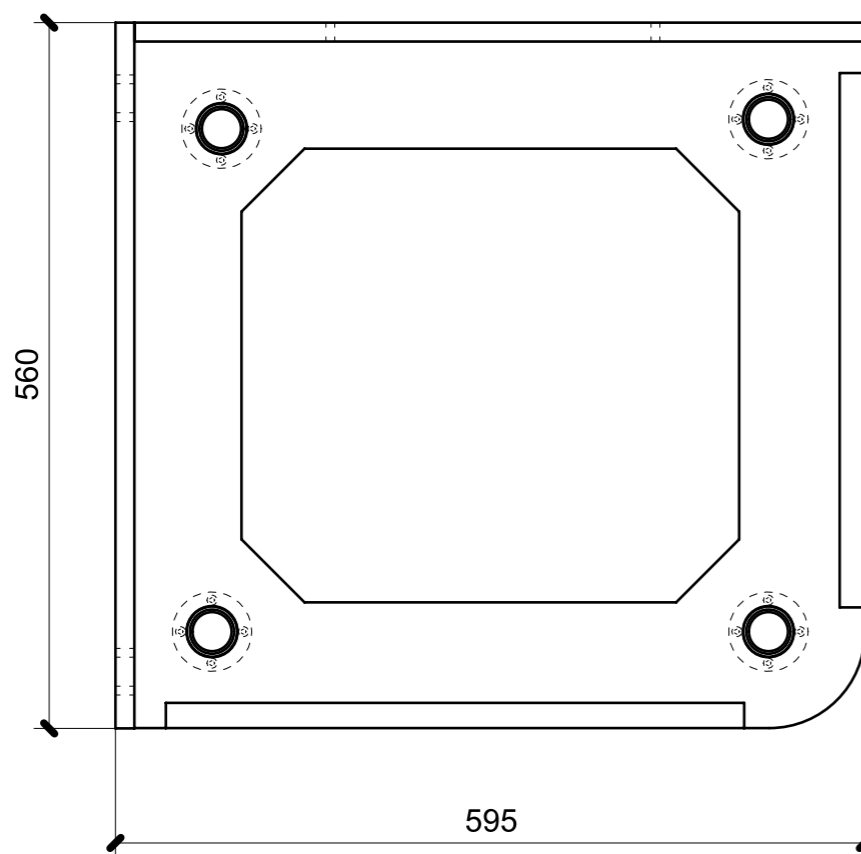
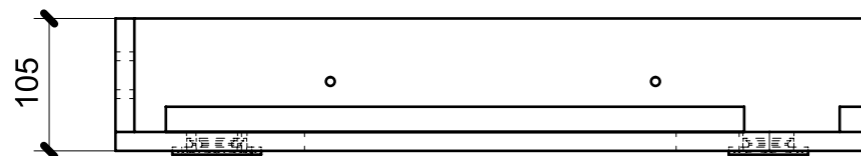

FERRAMENTA	QTY
FITLOCK F_MASCHERPA_6020101102	4