

LOCALE	CODICE	DESCRIZIONE COMPONENTE	FINITURA	Q.TA
CUCINA APERTA	MD299_R01_KA01	BASE LAVASTOVIGLIE	LASTRA SCURA	1

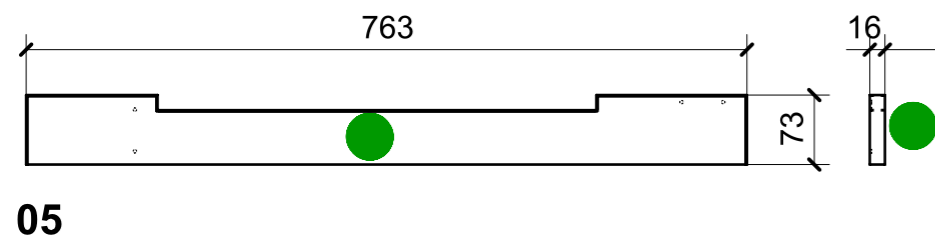
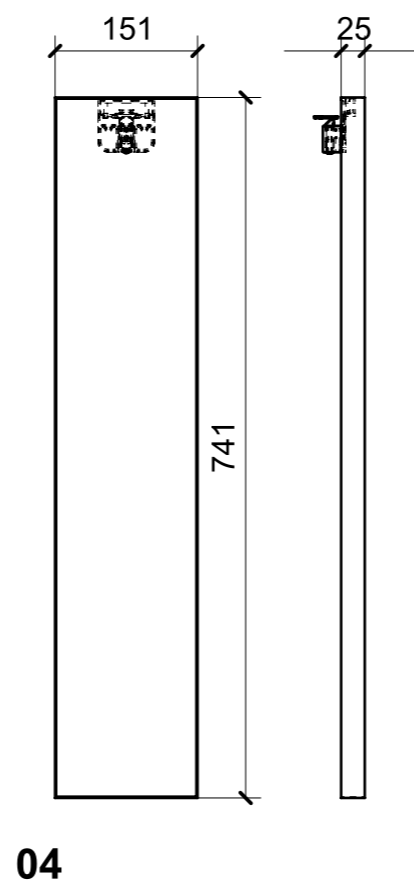
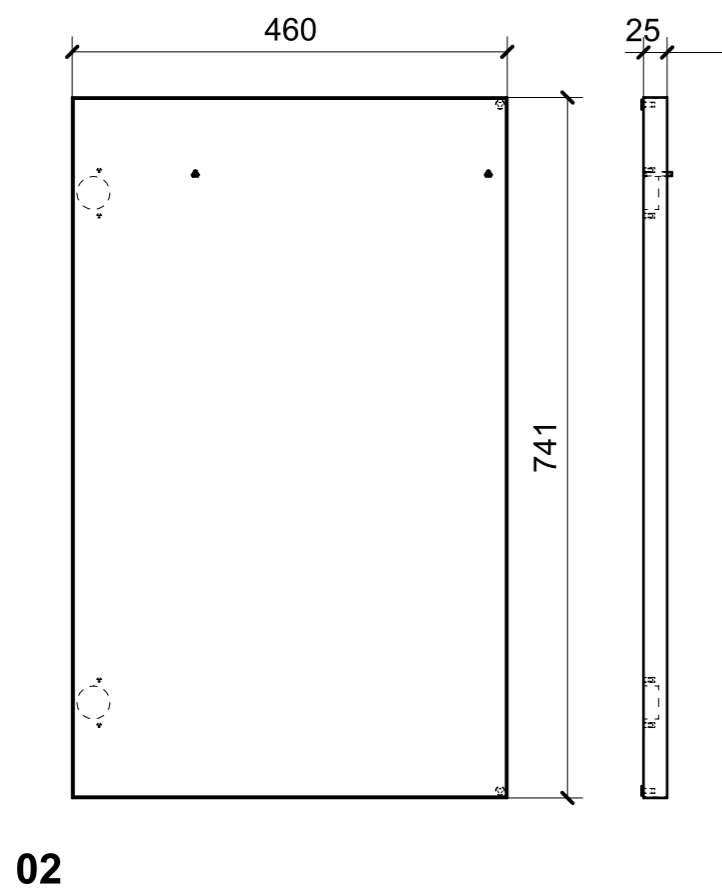
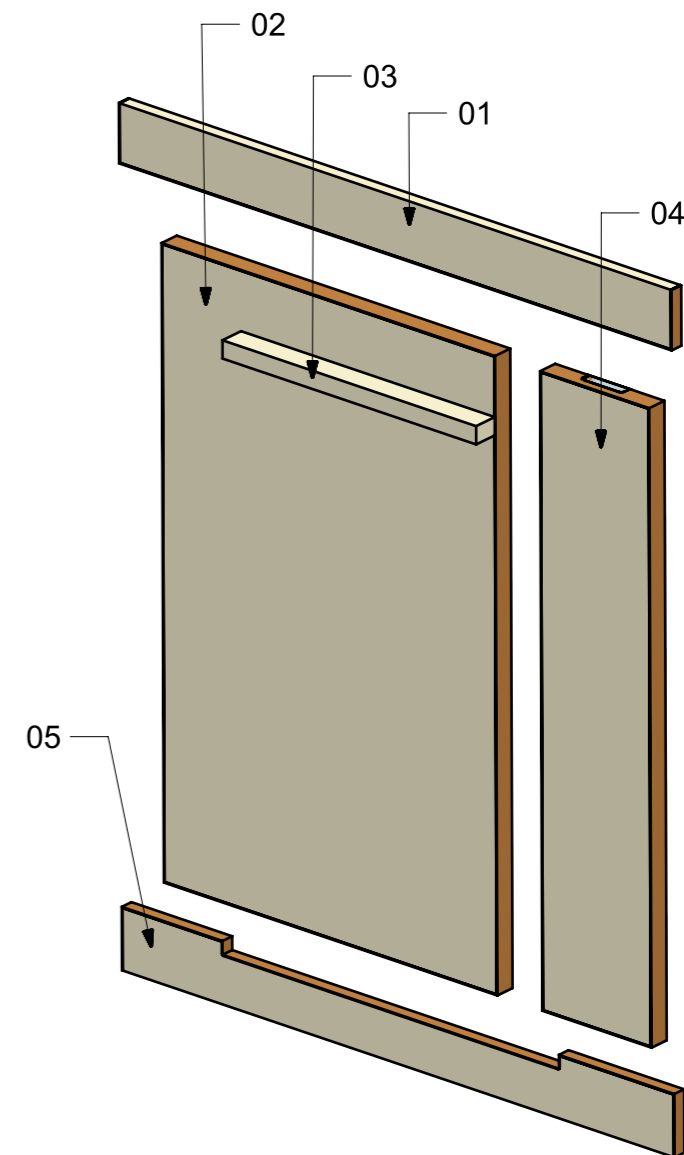
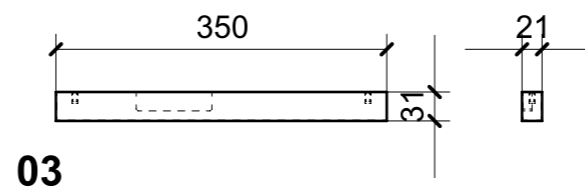
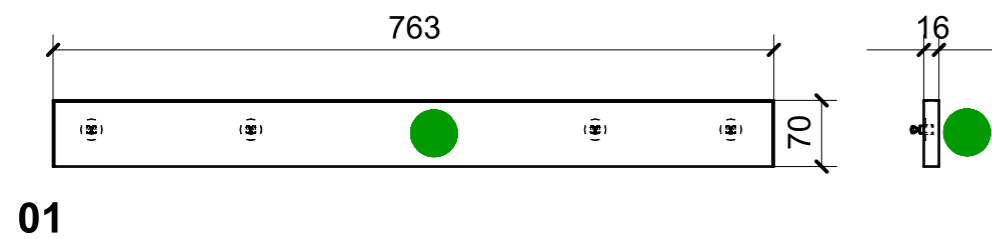

FERRAMENTA	QTY
BUSSOLA 4MA X 10 FORO DIAM.6	2
BUSSOLA 5MA ANKOR BORGHI X CERNIERA PIANA	4
GOMMINO PARACOLPO ANTA	2
MANIGLIA AD INCASSO_FORESTI_ART 238 C	1
MS INCASSO_ITALVIPLA_972_FMPC_M1B	4
VITE 4MA X 30 TESTA SVASATA ESAGONALE NERA	2

VERNICIATURA LASTRA/LACCATI:

● = VERNICIARE 1 LATO + FILI RASATI O BORDATI

NESSUN SIMBOLO = VERNICIARE 2 LATI + FILI RASATI O BORDATI

LOCALE	CODICE	DESCRIZIONE COMPONENTE	FINITURA	Q.TA
CUCINA APERTA	MD299_R01_KB01	MURETTO DIVISORIO BASE ANGOLO_STD VAR 1	LASTRA SCURA	1

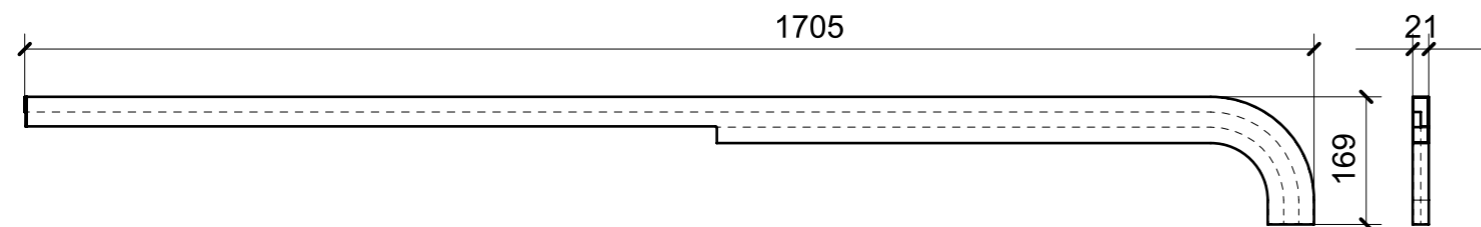

01

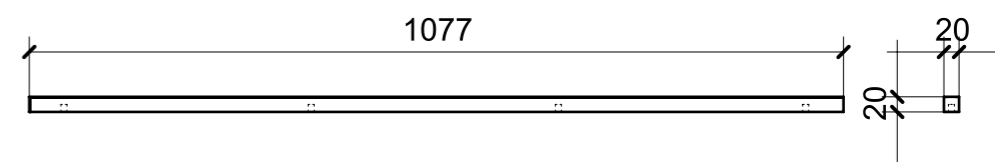

03

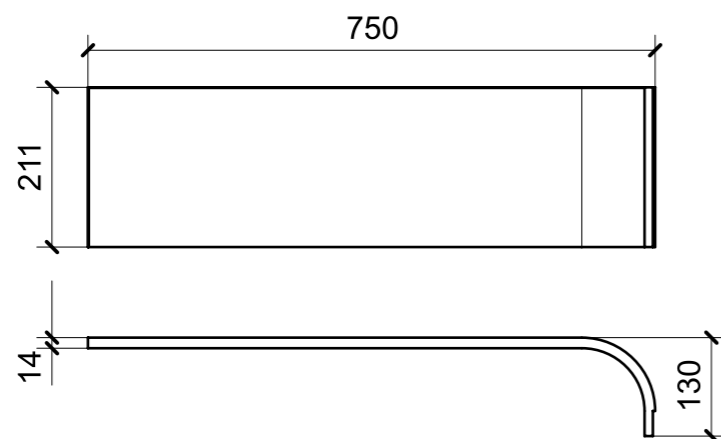

02

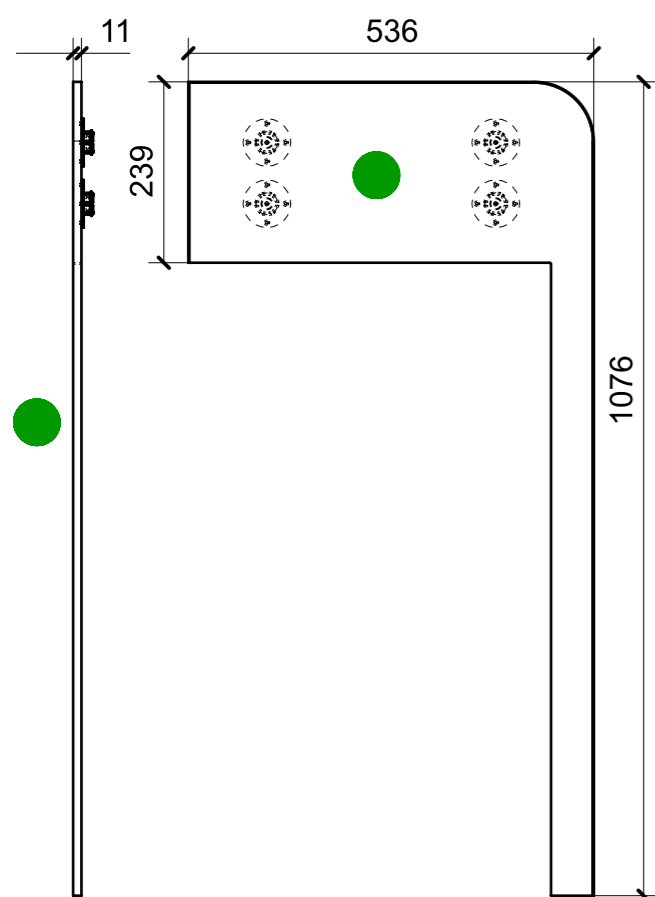

04

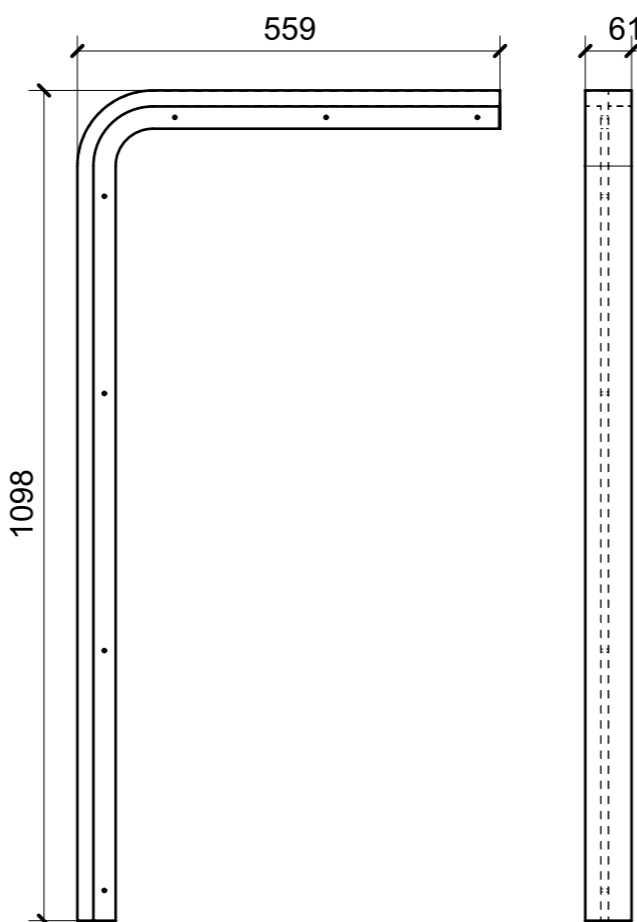

05

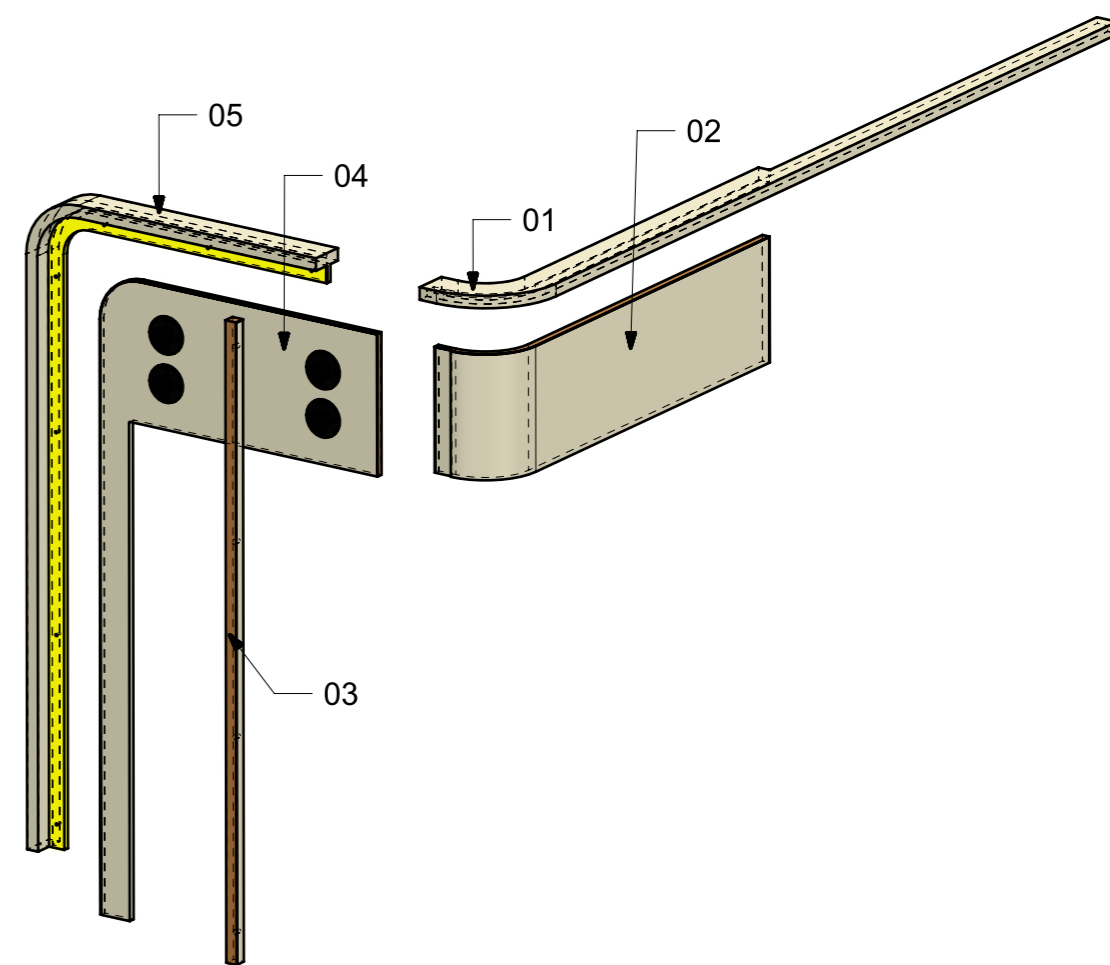

FERRAMENTA	QTY
FITLOCK M_MASCHERPA_3MM_6020202101	4

VERNICIATURA LASTRA/LACCATI:

● = VERNICIARE 1 LATO + FILI RASATI O BORDATI

NESSUN SIMBOLO = VERNICIARE 2 LATI + FILI RASATI O BORDATI

LOCALE	CODICE	DESCRIZIONE COMPONENTE	FINITURA	Q.TA
CUCINA CHIUSA	MD299_R01_KKB01	MURETTO DIVISORIO BASE ANGOLO_STD VAR 2	LASTRA SCURA	1

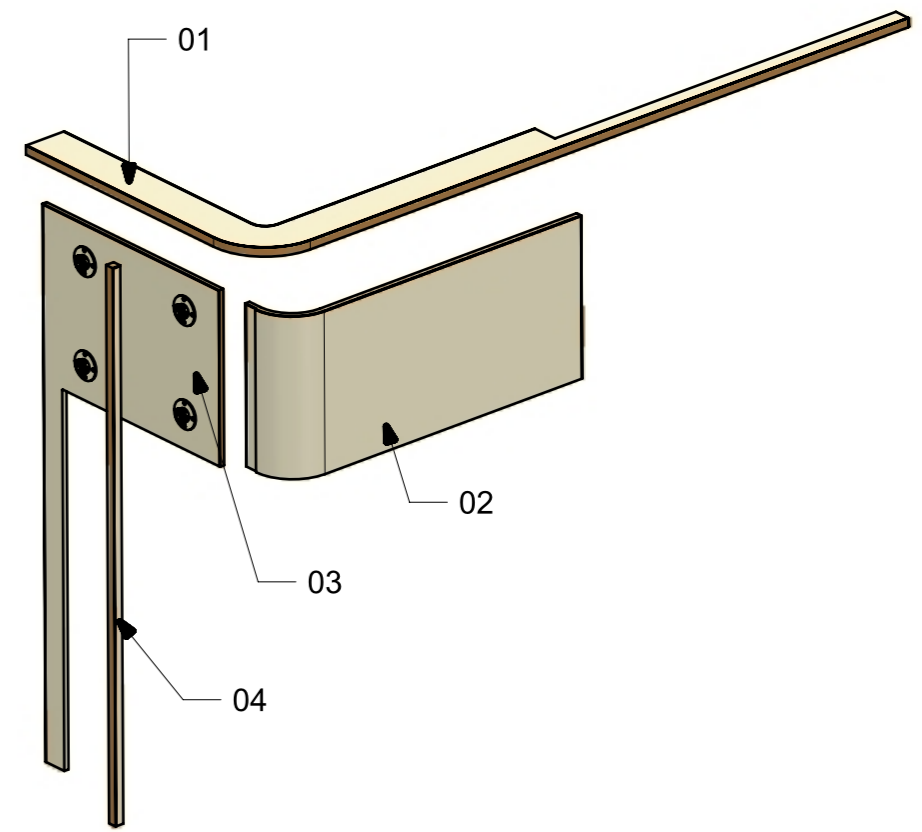
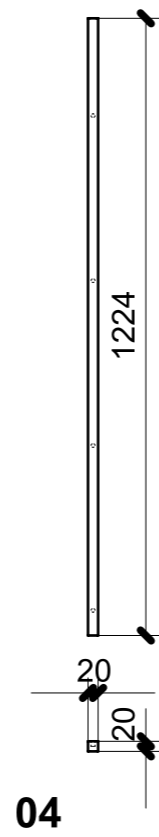
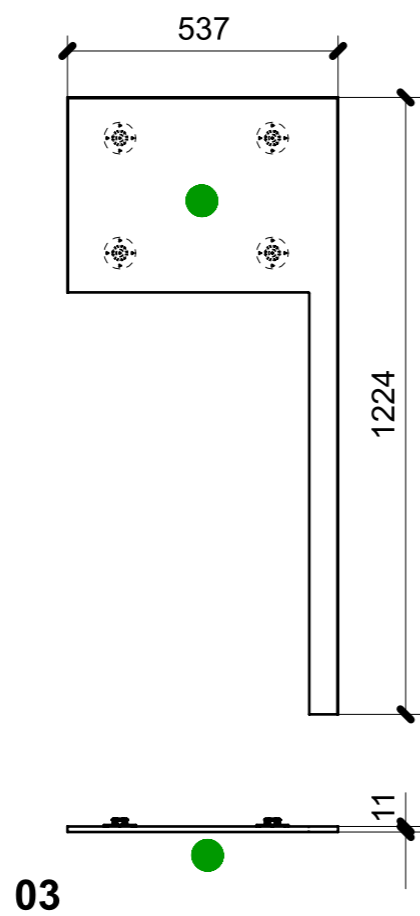
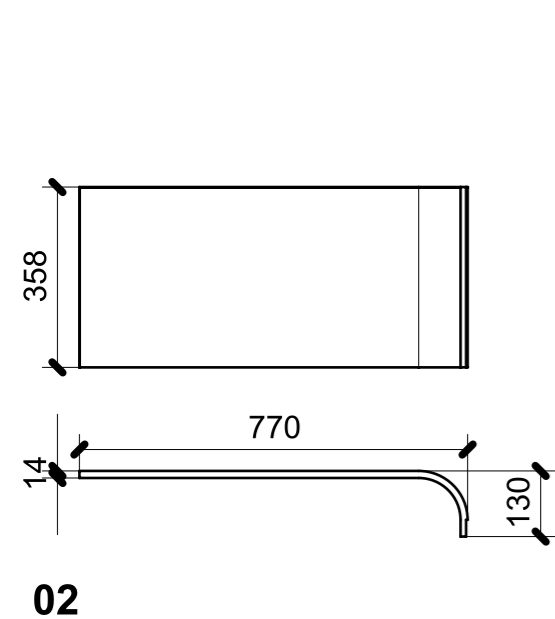
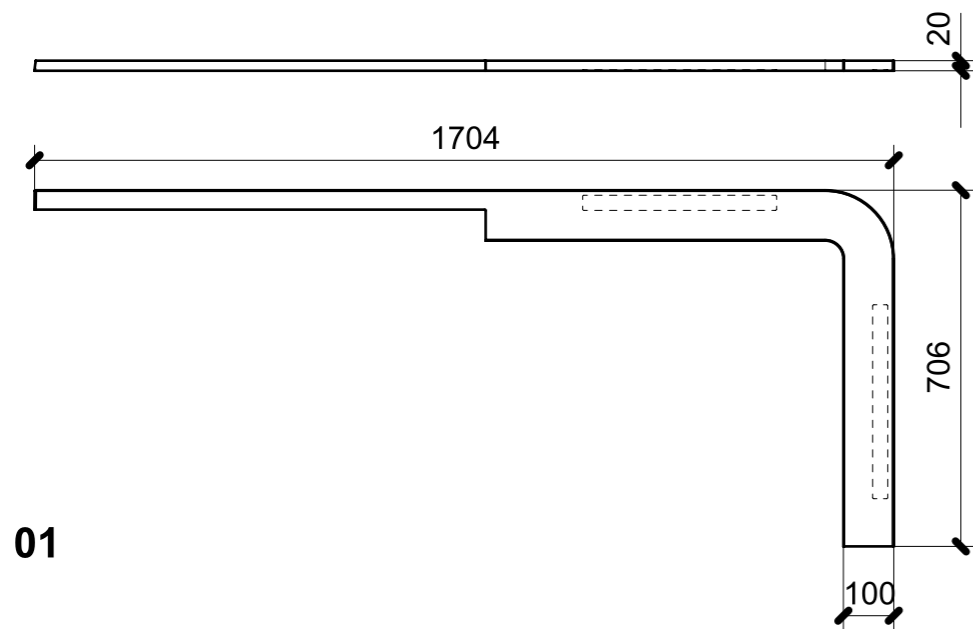

FERRAMENTA	QTY
FITLOCK M_MASCHERPA_3MM_6020202101	4

VERNICIATURA LASTRA/LACCATI:

● = VERNICIARE 1 LATO + FILI RASATI O BORDATI

NESSUN SIMBOLO = VERNICIARE 2 LATI + FILI RASATI O BORDATI

LOCALE	CODICE	DESCRIZIONE COMPONENTE	FINITURA	Q.TA
CUCINA APERTA	MD299_R01_KC01	BASE ANGOLO	LASTRA SCURA	1

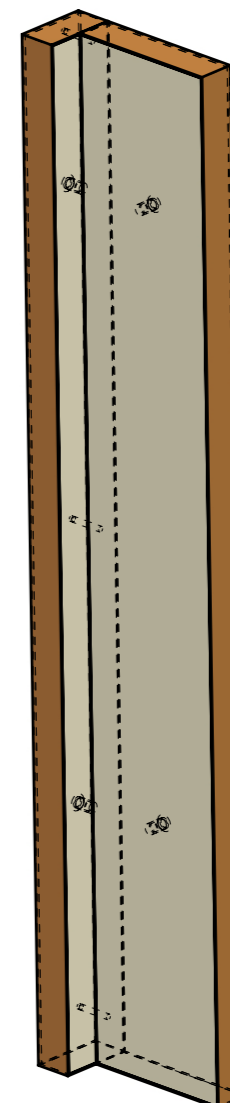
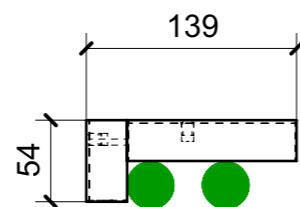
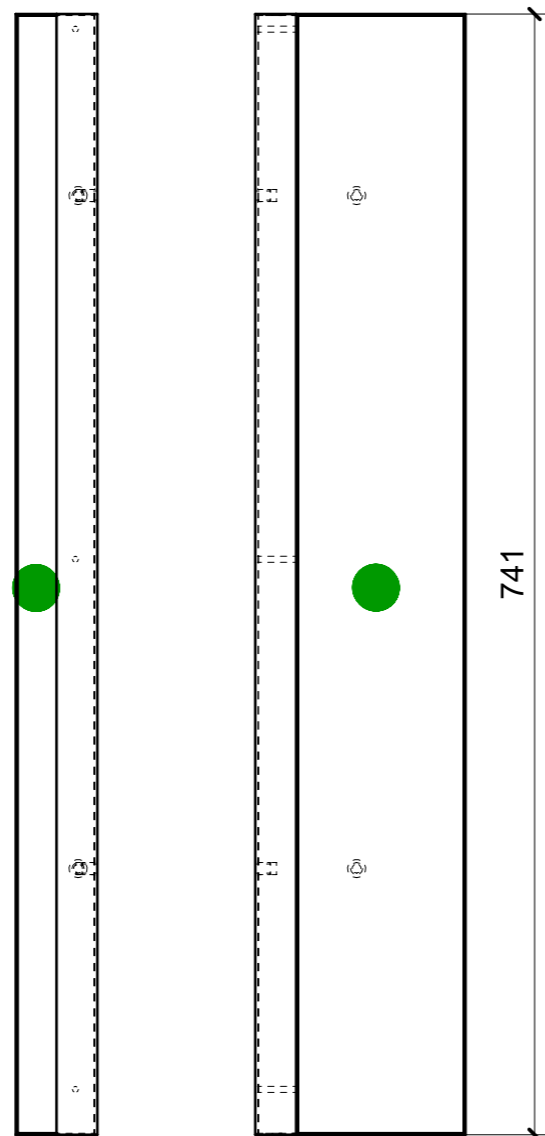

FERRAMENTA	QTY
FM INCASSO_ITALVIPLA_973_FMPC_F1A	1
BUSSOLA 6MA X 10 FORO DIAM.8	4

VERNICIATURA LASTRA/LACCATI:

● = VERNICIARE 1 LATO + FILI RASATI O BORDATI

NESSUN SIMBOLO = VERNICIARE 2 LATI + FILI RASATI O BORDATI

LOCALE	CODICE	DESCRIZIONE COMPONENTE	FINITURA	Q.TA
CUCINA APERTA	MD299_R01_KD01	BASE LAVELLO E FORNO	LASTRA SCURA	1

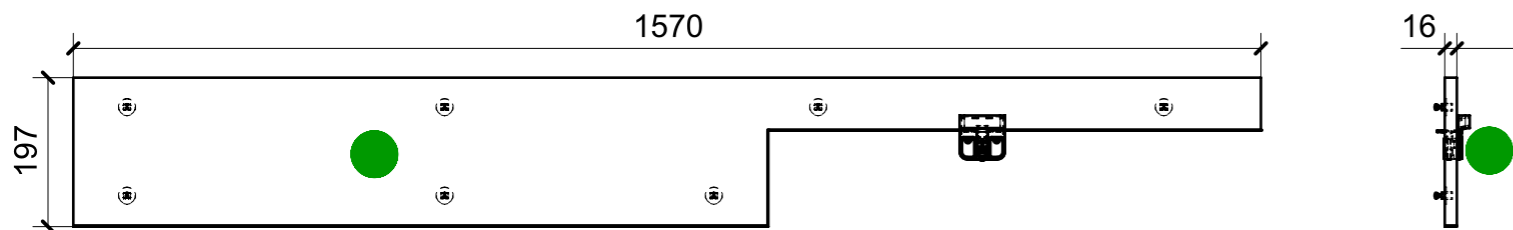

01

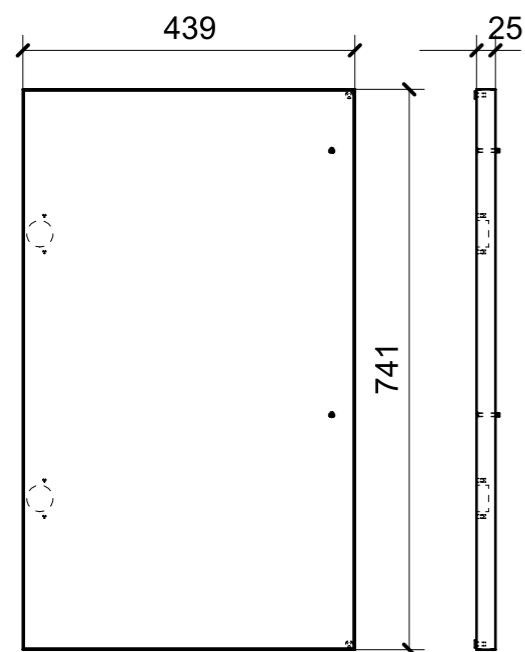

03

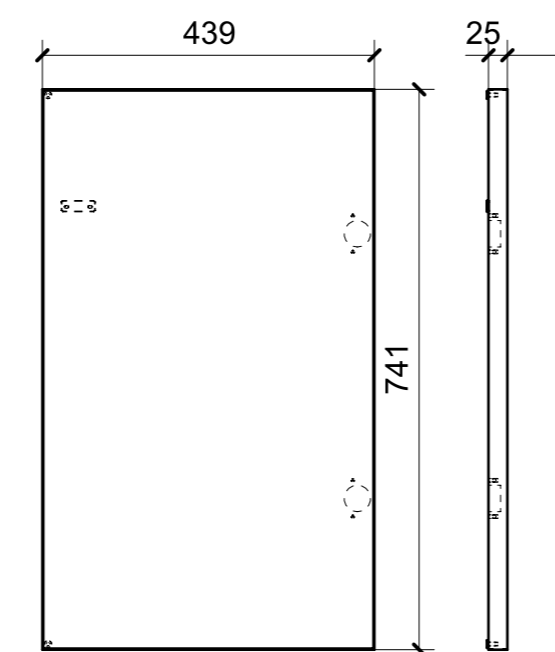

04

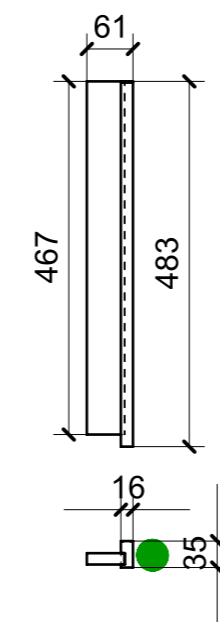

02

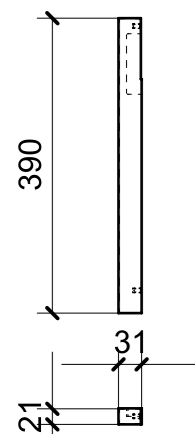
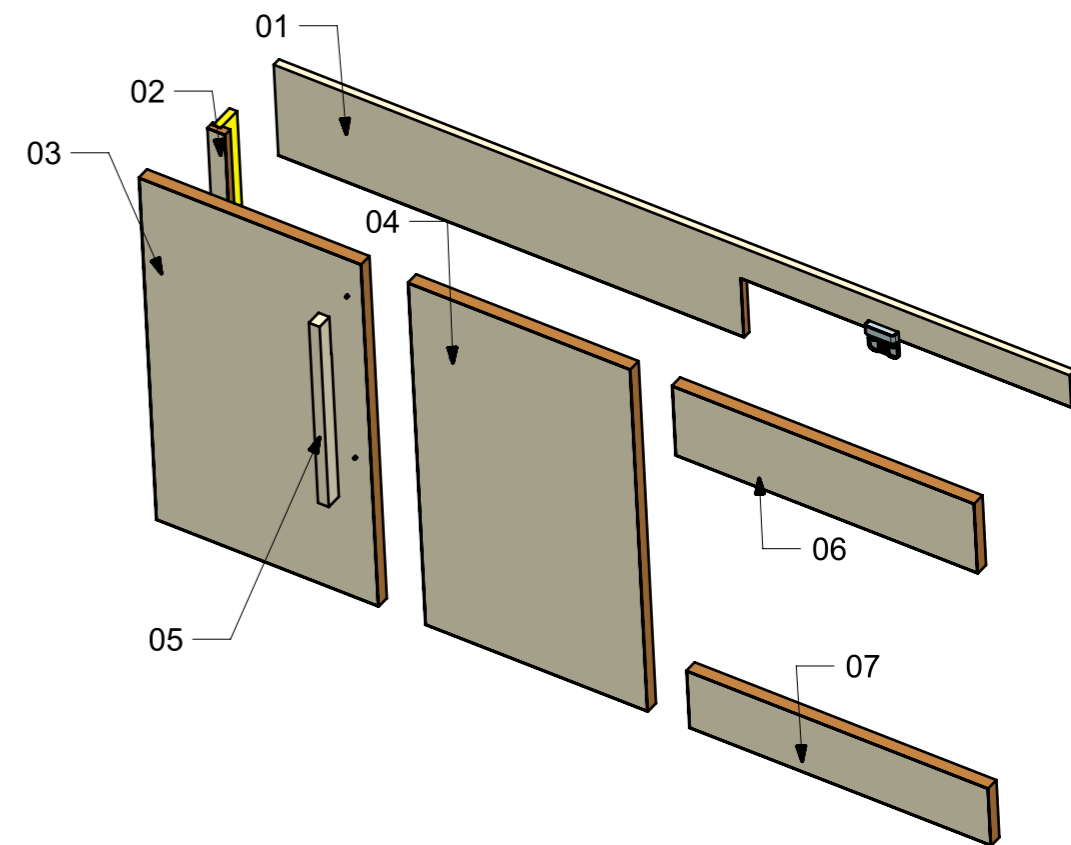

05

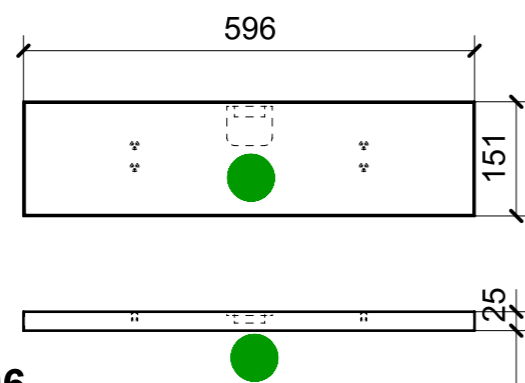

06

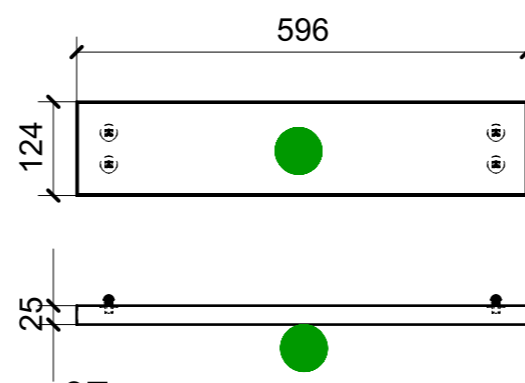

07

FERRAMENTA	QTY
BUSSOLA 4MA X 10 FORO DIAM.6	2
BUSSOLA 5MA ANKOR BORGHI X CERNIERA PIANA	8
BUSSOLA 5MA X 10 FORO DIAM.8	4
GOMMINO PARACOLPO ANTA	4
MANIGLIA AD INCASSO_FORESTI_ART 238 C	1
MS INCASSO_ITALVIPLA_972_FMPC_M1B	11
PLACCHETTA COUNTER STEEL_TECHNOPARTNER_MC-JM49	1
VITE 4MA X 30 TESTA SVASATA ESAGONALE NERA	2

VERNICIATURA LASTRA/LACCATI:

● = VERNICIARE 1 LATO + FILI RASATI O BORDATI

NESSUN SIMBOLO = VERNICIARE 2 LATI + FILI RASATI O BORDATI

LOCALE	CODICE	DESCRIZIONE COMPONENTE	FINITURA	Q.TA
CUCINA APERTA	MD299_R01_KE01	BASE FRIGO	LASTRA SCURA	1

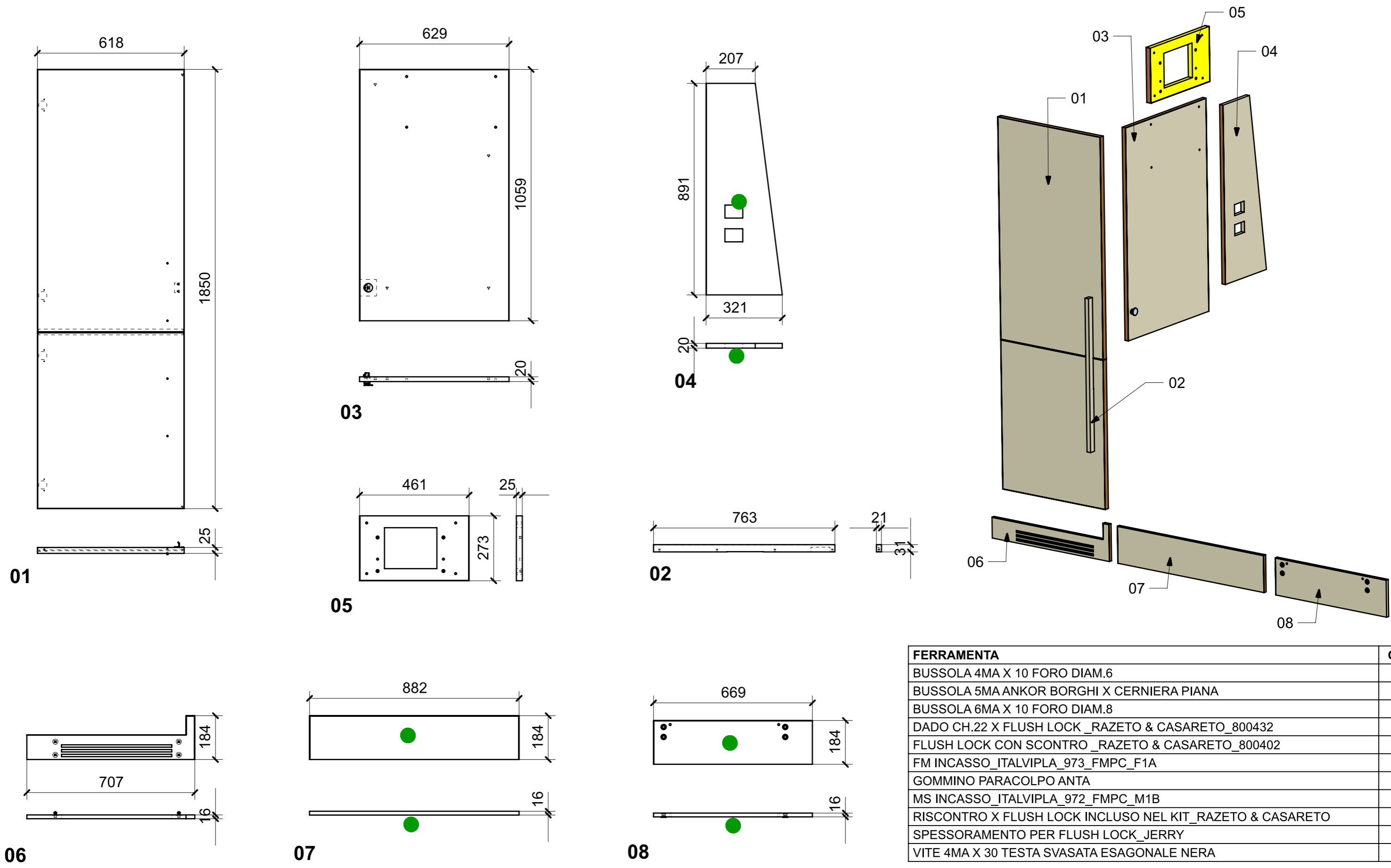

FERRAMENTA	QTY
BUSSOLA 4MA X 10 FORO DIAM.6	4
BUSSOLA 5MA ANKOR BORGHI X CERNIERA PIANA	8
BUSSOLA 6MA X 10 FORO DIAM.8	8
DADO CH.22 X FLUSH LOCK _RAZETO & CASARETO_800432	1
FLUSH LOCK CON SCONTRO _RAZETO & CASARETO_800402	1
FM INCASSO_ITALVIPLA_973_FMPC_F1A	4
GOMMINO PARACOLPO ANTA	2
MS INCASSO_ITALVIPLA_972_FMPC_M1B	4
RISCONTRO X FLUSH LOCK INCLUSO NEL KIT _RAZETO & CASARETO	1
SPESSORAMENTO PER FLUSH LOCK_JERRY	1
VITE 4MA X 30 TESTA SVASATA ESAGONALE NERA	4

**VERNICIATURA LASTRA/LACCATI:**

● = VERNICIARE 1 LATO + FILI RASATI O BORDATI

NESSUN SIMBOLO = VERNICIARE 2 LATI + FILI RASATI O BORDATI

LOCALE	CODICE	DESCRIZIONE COMPONENTE	FINITURA	Q.TA
CUCINA APERTA	MD299_R01_KF01	FIANCO FRIGO A POPPA	LASTRA SCURA	1

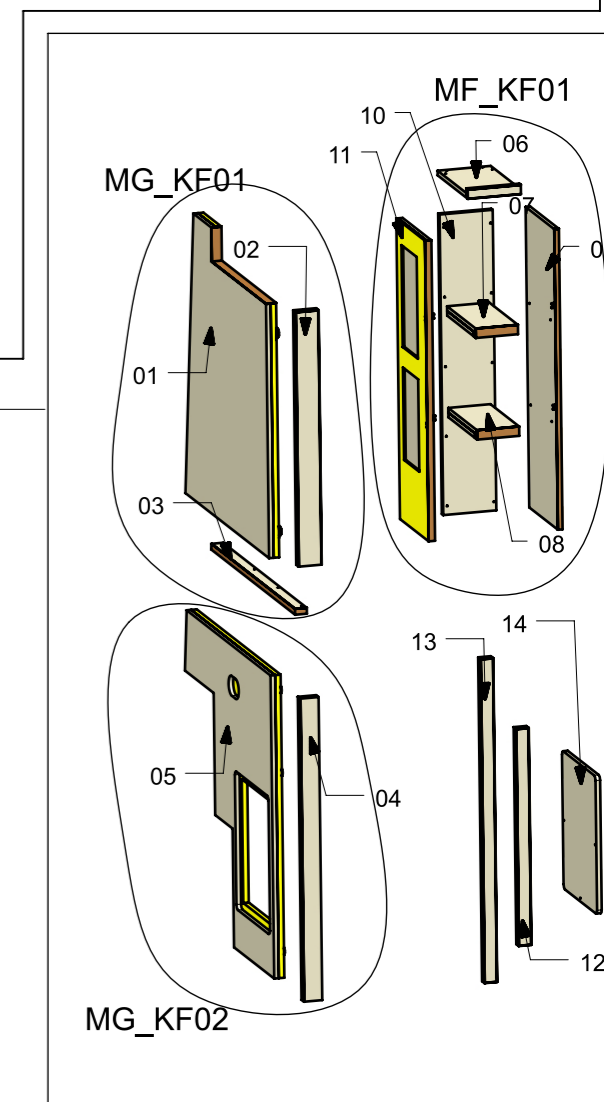
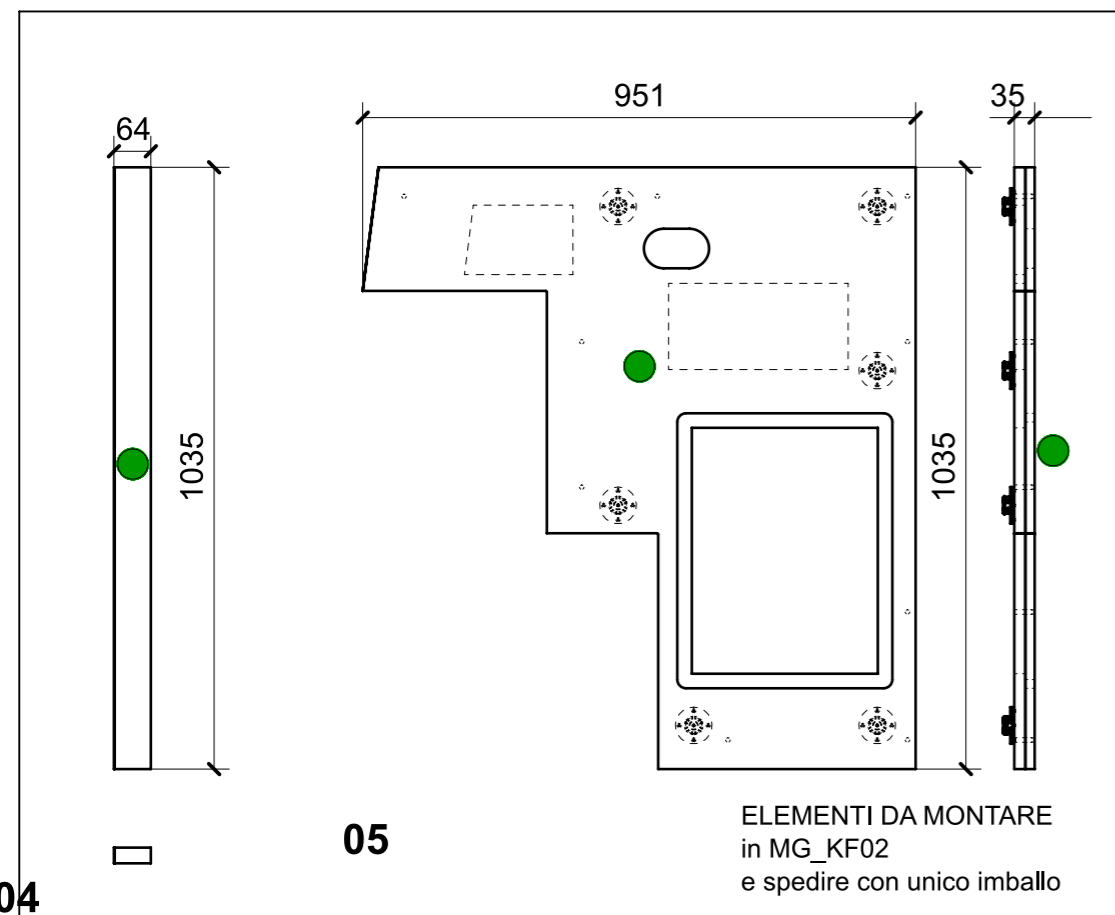
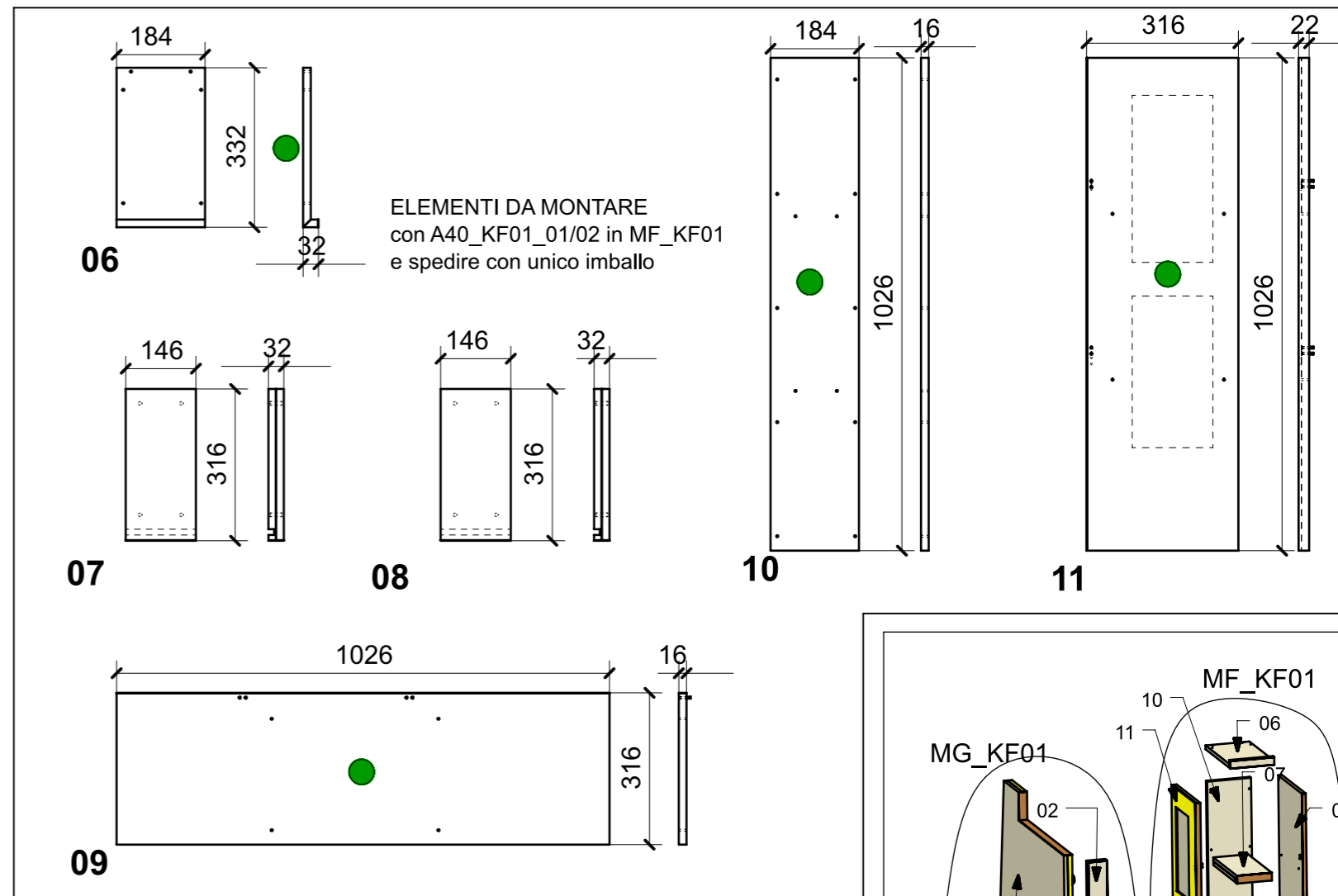
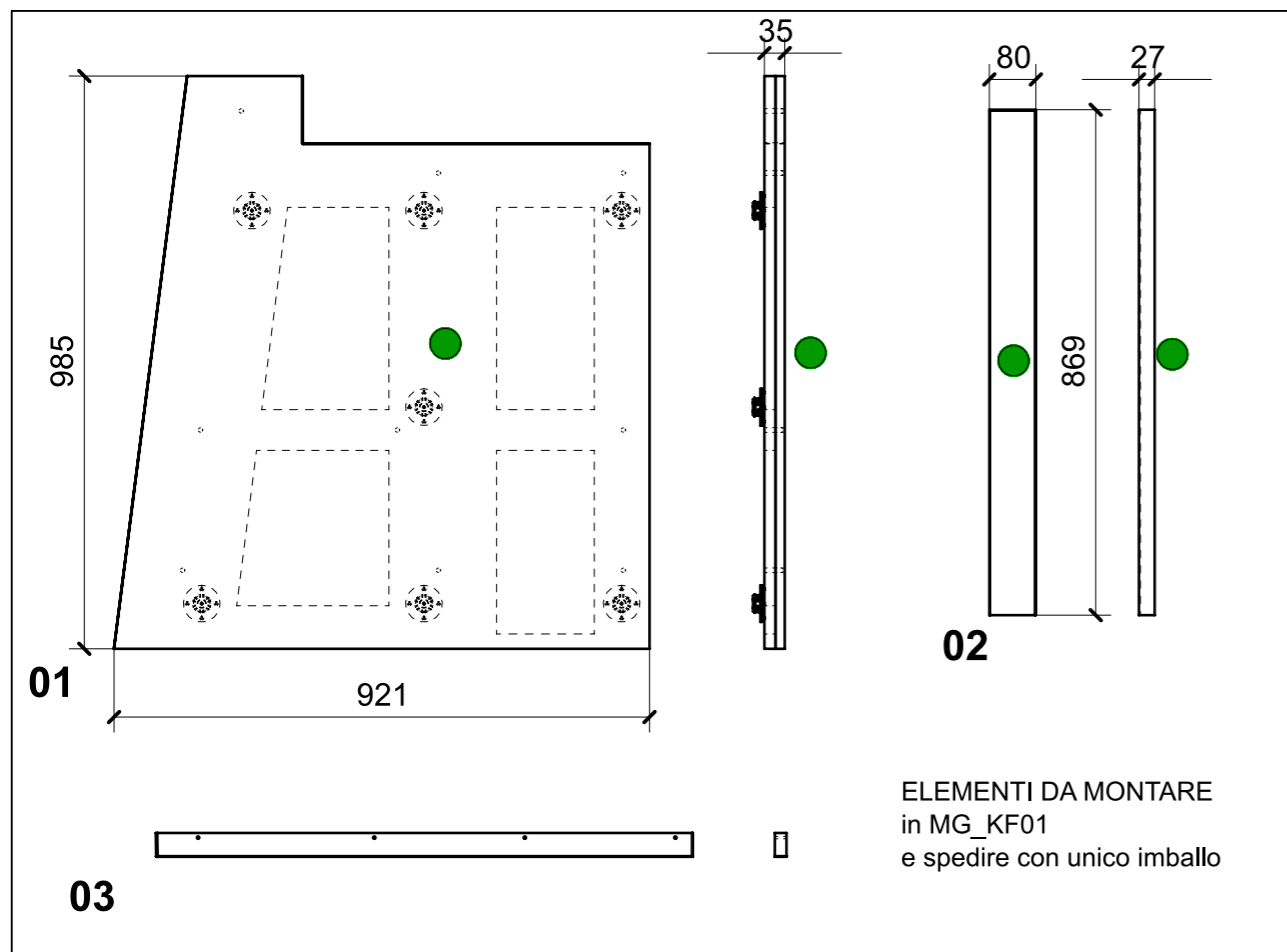

FERRAMENTA	QTY
VITE 4MA X 25 TESTA SVASATA ESAGONALE NERA	8
MS INCASSO_ITALVIPLA_972_FMPC_M1B	3
FITLOCK M_MASCHERPA_3MM_6020202101	13

VERNICIATURA LASTRA/LACCATI:

● = VERNICIARE 1 LATO + FILI RASATI O BORDATI

NESSUN SIMBOLO = VERNICIARE 2 LATI + FILI RASATI O BORDATI

LOCALE	CODICE	DESCRIZIONE COMPONENTE	FINITURA	Q.TA
CUCINA APERTA	MD299_R01_KG01	BASE CUCINA DINING	LASTRA SCURA	1

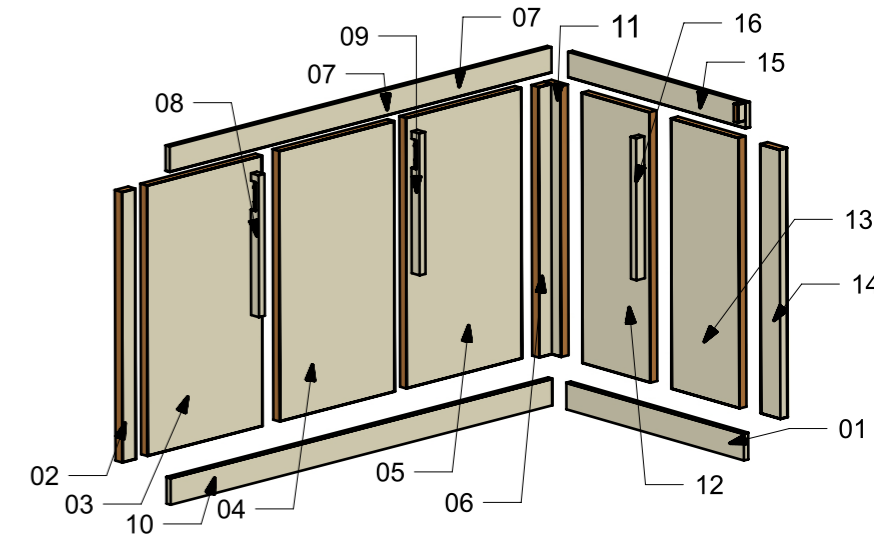
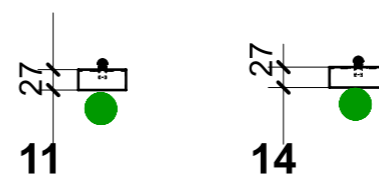
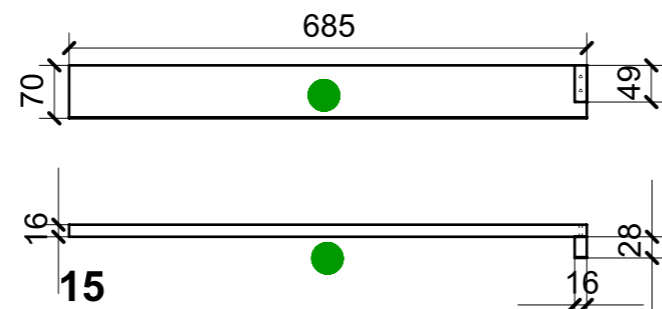
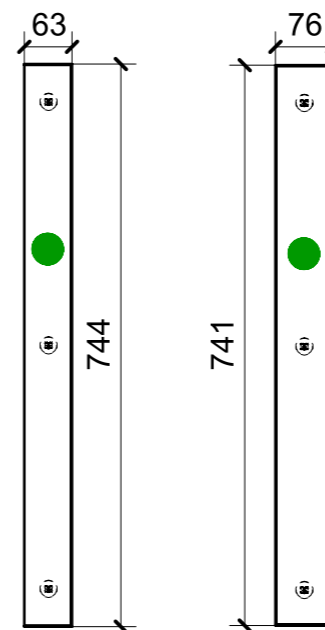
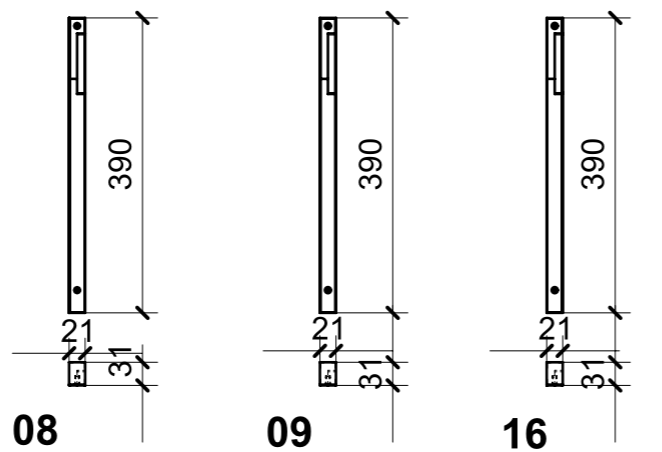
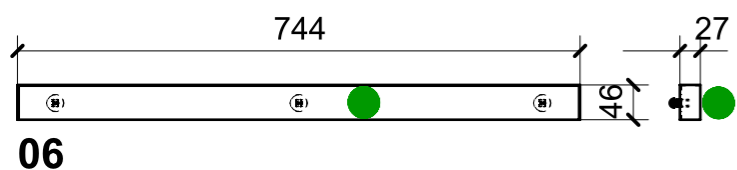
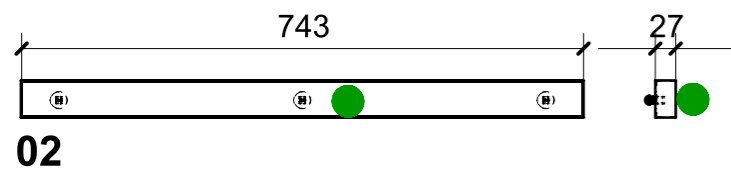
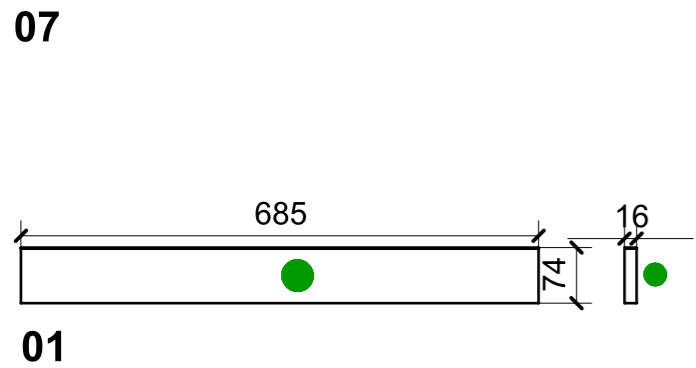
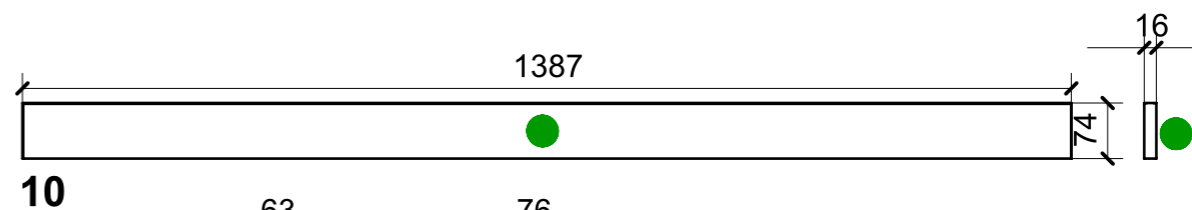
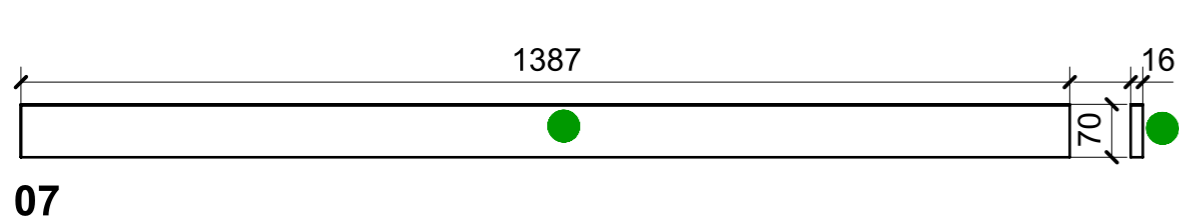
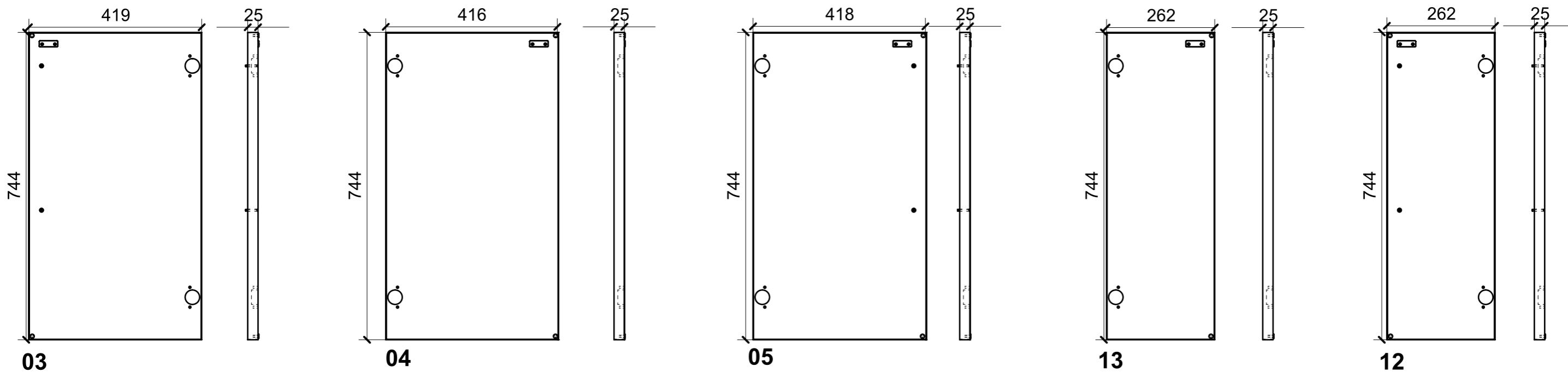

FERRAMENTA	QTY
BUSSOLA 4MA X 10 FORO DIAM.6	6
GOMMINO PARACOLPO ANTA	10
MS INCASSO_ITALVIPLA_972_FMPC_M1B	12
PLACCHETTA COUNTER STEEL_TECHNOPARTNER_MC-JM49	5
VITE 4MA X 30 TESTA SVASATA ESAGONALE NERA	6

VERNICIATURA LASTRA/LACCATI:

● = VERNICIARE 1 LATO + FILI RASATI O BORDATI

NESSUN SIMBOLO = VERNICIARE 2 LATI + FILI RASATI O BORDATI

LOCALE	CODICE	DESCRIZIONE COMPONENTE	FINITURA	Q.TA
CUCINA APERTA	MD299_R01_KH01	RIVESTIMENTO LABELLE BASE DINING_STD VAR 1	LASTRA SCURA	1

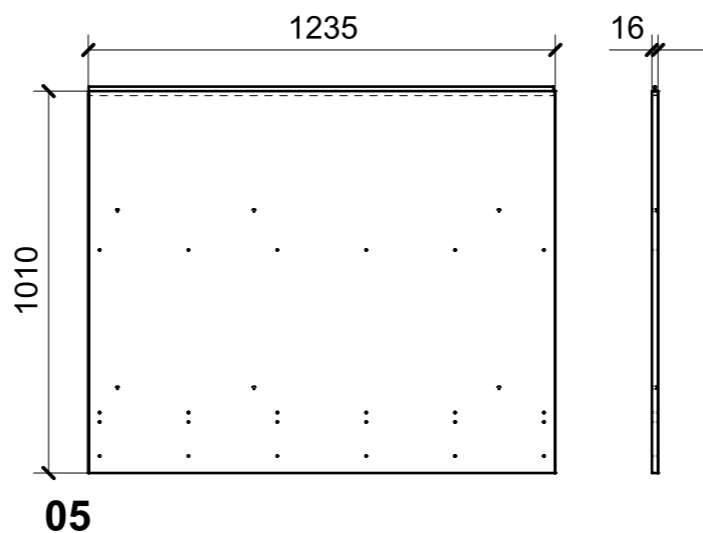
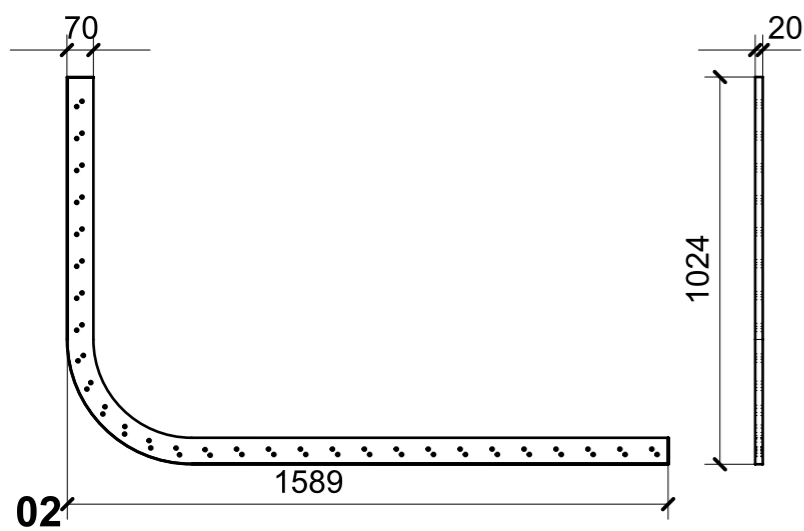
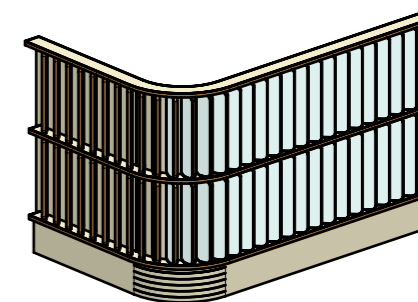
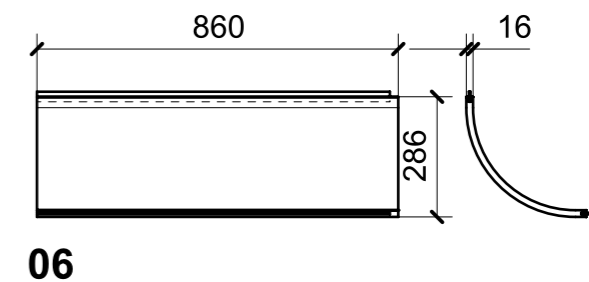
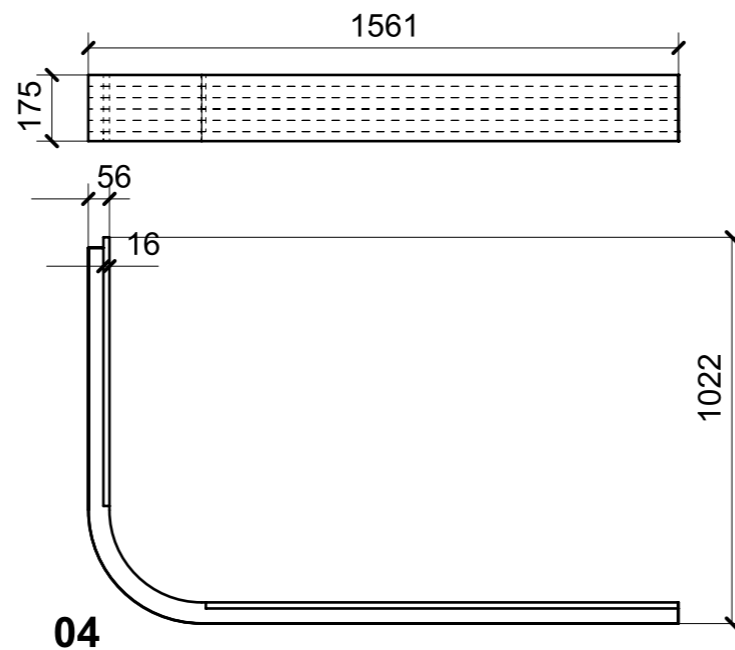
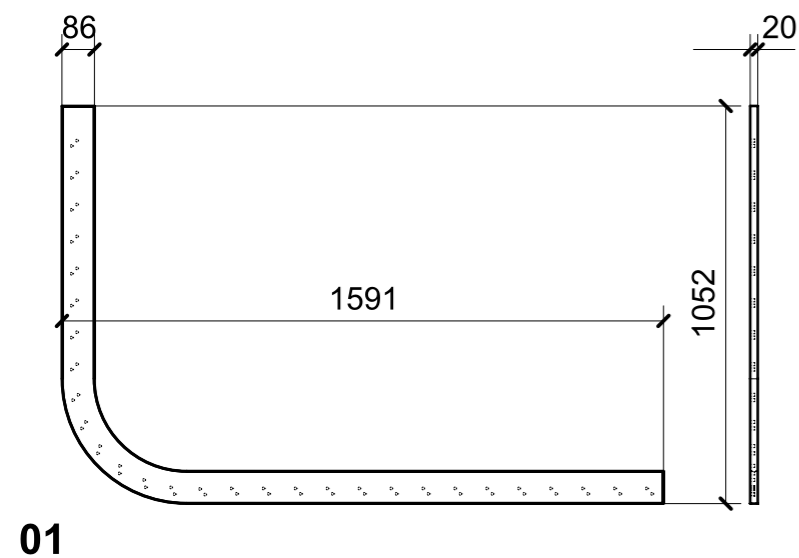

ELEMENTI DA MONTARE  
CON X01\_KH01\_01 IN MF\_KH01  
e spedire con unico imballo

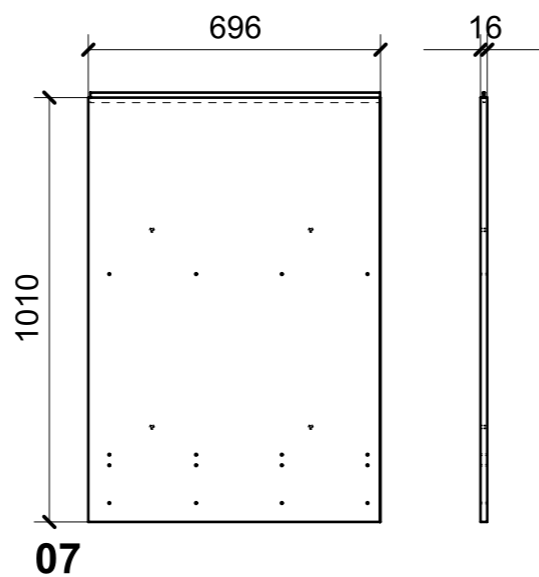
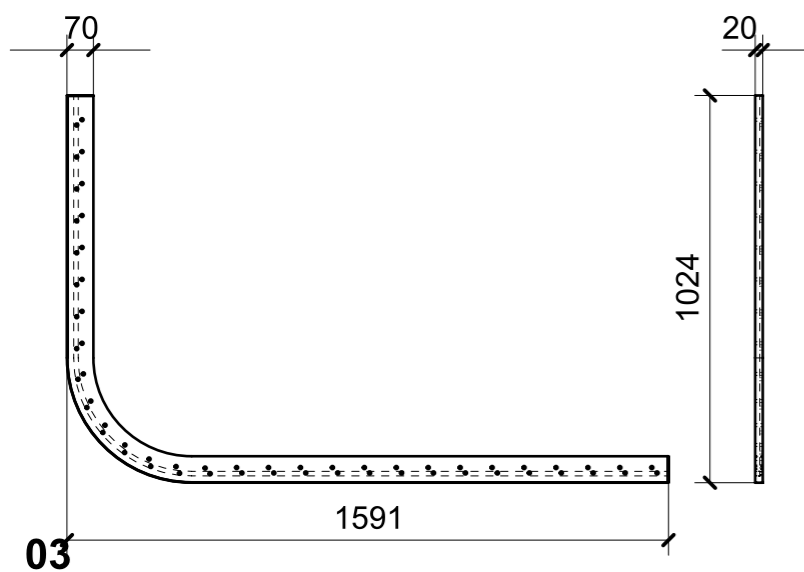
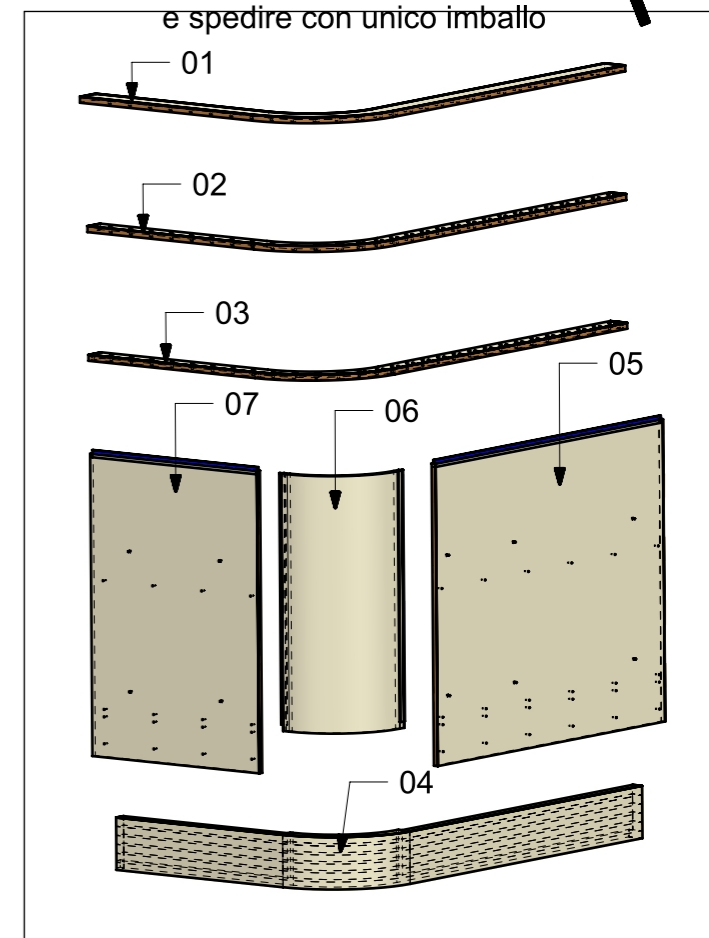

FERRAMENTA	QTY
BUSSOLA 6MA X 10 FORO DIAM.8	10

VERNICIATURA LASTRA/LACCATI:

● = VERNICIARE 1 LATO + FILI RASATI O BORDATI

NESSUN SIMBOLO = VERNICIARE 2 LATI + FILI RASATI O BORDATI

LOCALE	CODICE	DESCRIZIONE COMPONENTE	FINITURA	Q.TA
CUCINA APERTA	MD299_R01_KKH01	RIVESTIMENTO LAMELLE BASE DINING_STD VAR 2	LASTRA SCURA	1

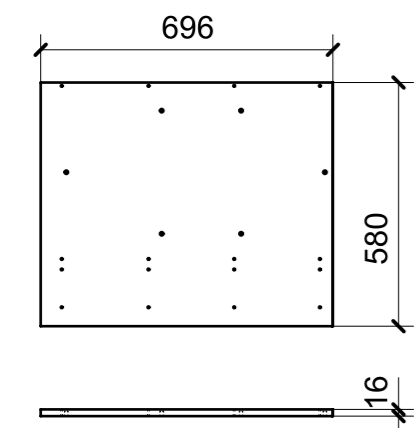
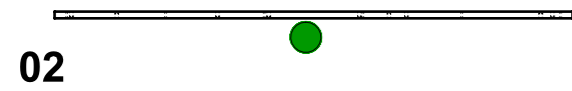
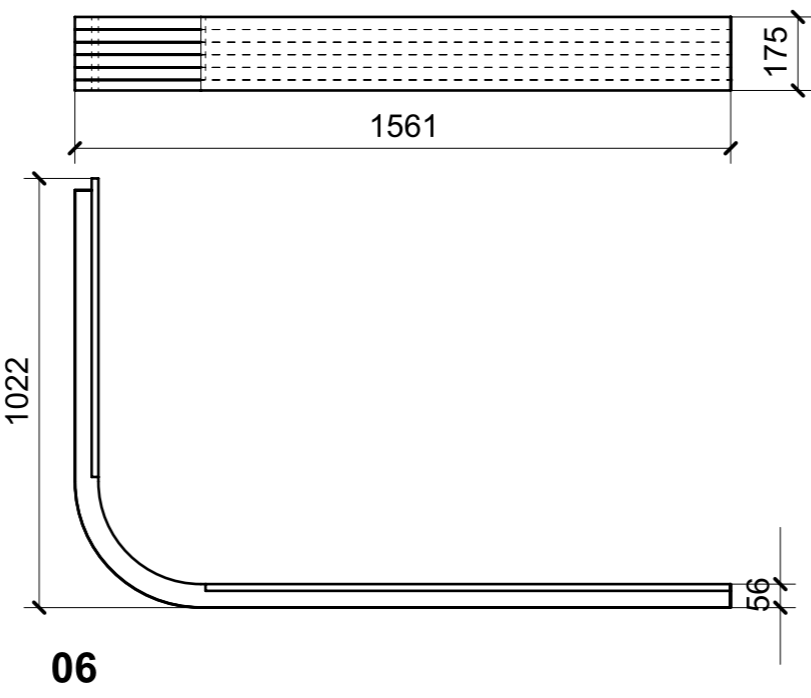
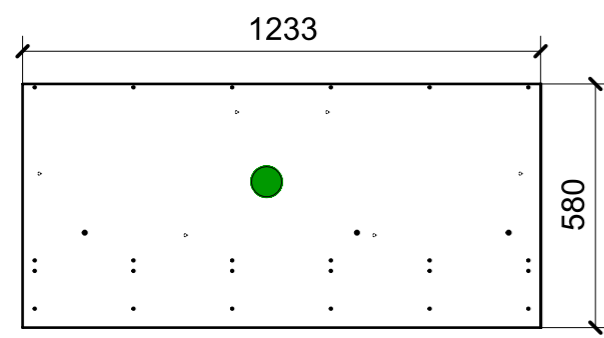
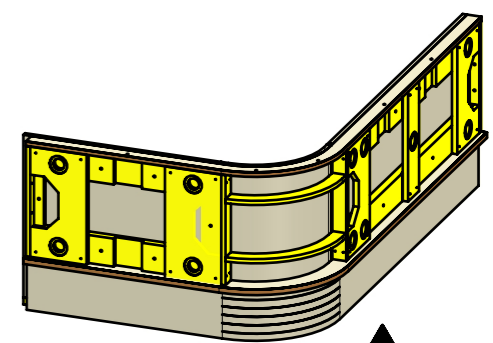
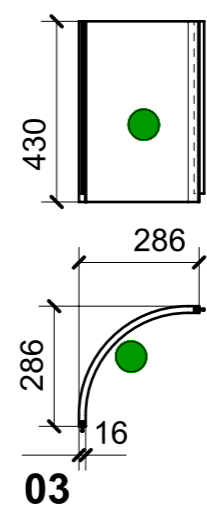
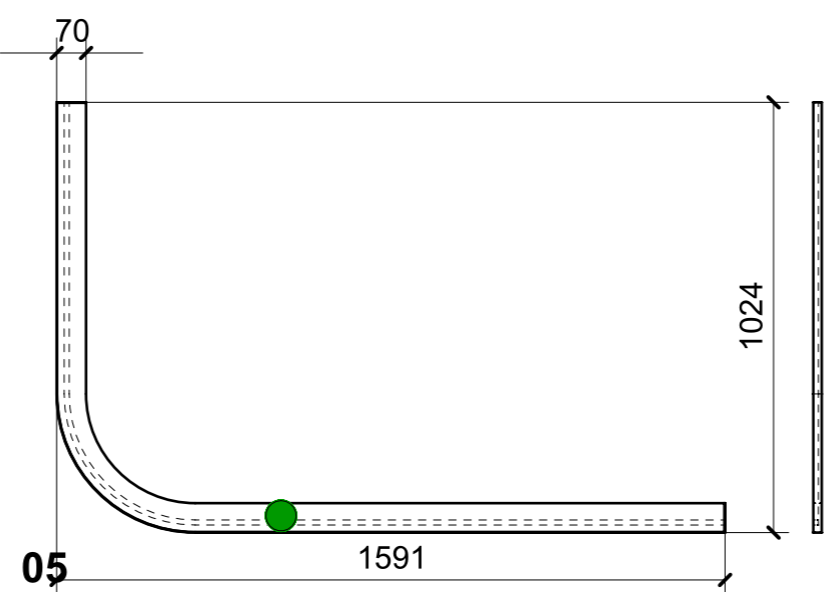
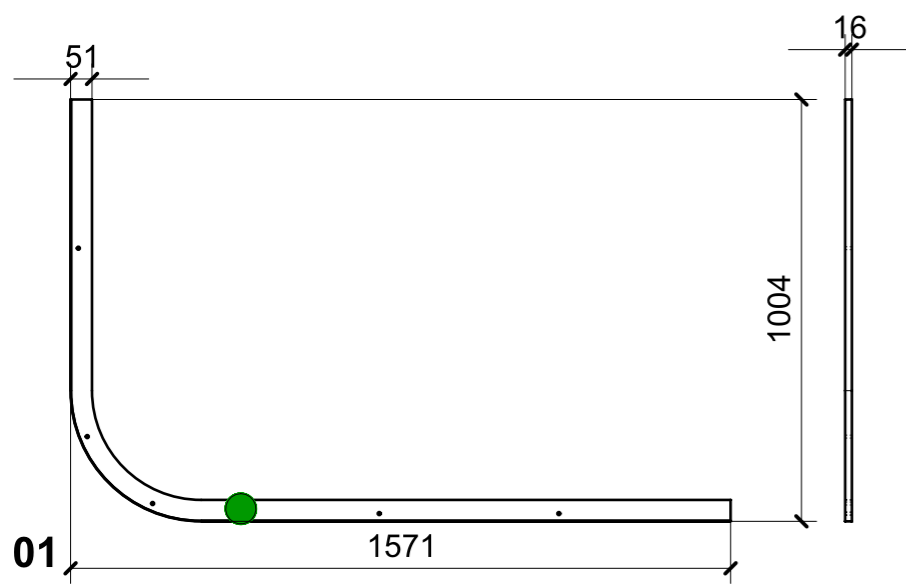

ELEMENTI DA MONTARE CON KKH01\_01/03  
IN MF\_KKH01  
e spedire con unico imballo

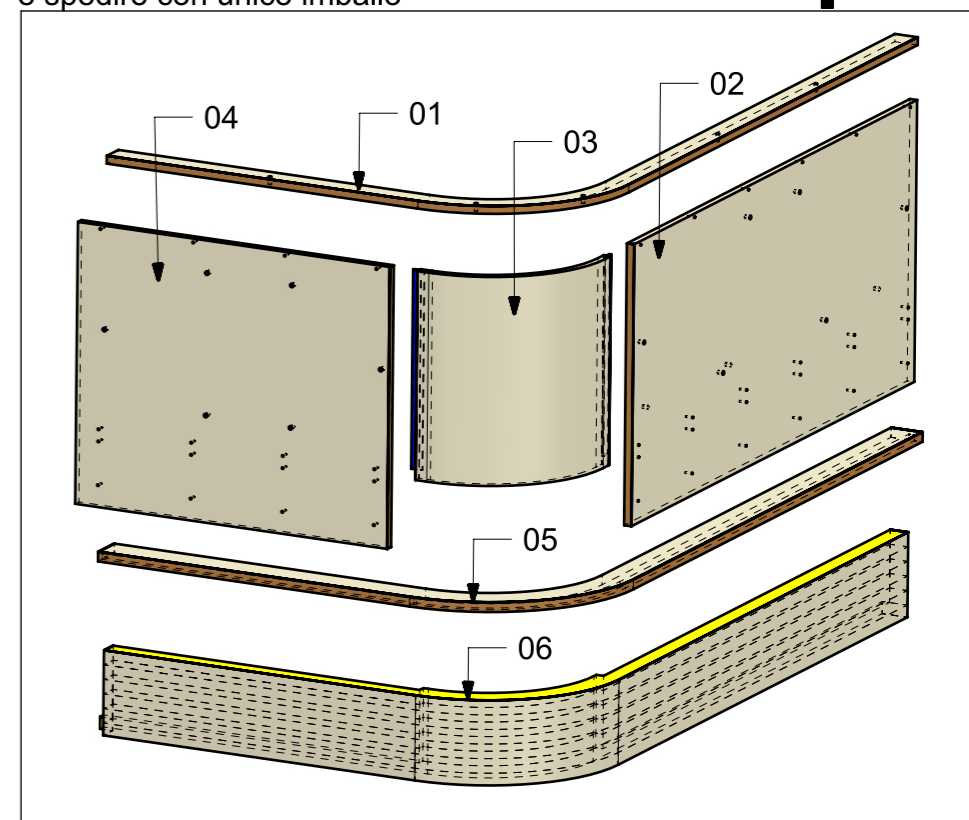

04

VERNICIATURA LASTRA/LACCATI:  
● = VERNICIARE 1 LATO + FILI RASATI O BORDATI  
NESSUN SIMBOLO = VERNICIARE 2 LATI + FILI RASATI O BORDATI

LOCALE	CODICE	DESCRIZIONE COMPONENTE	FINITURA	Q.TA
CUCINA APERTA	MD299_R01_KI01	PENSILE	LASTRA SCURA	1

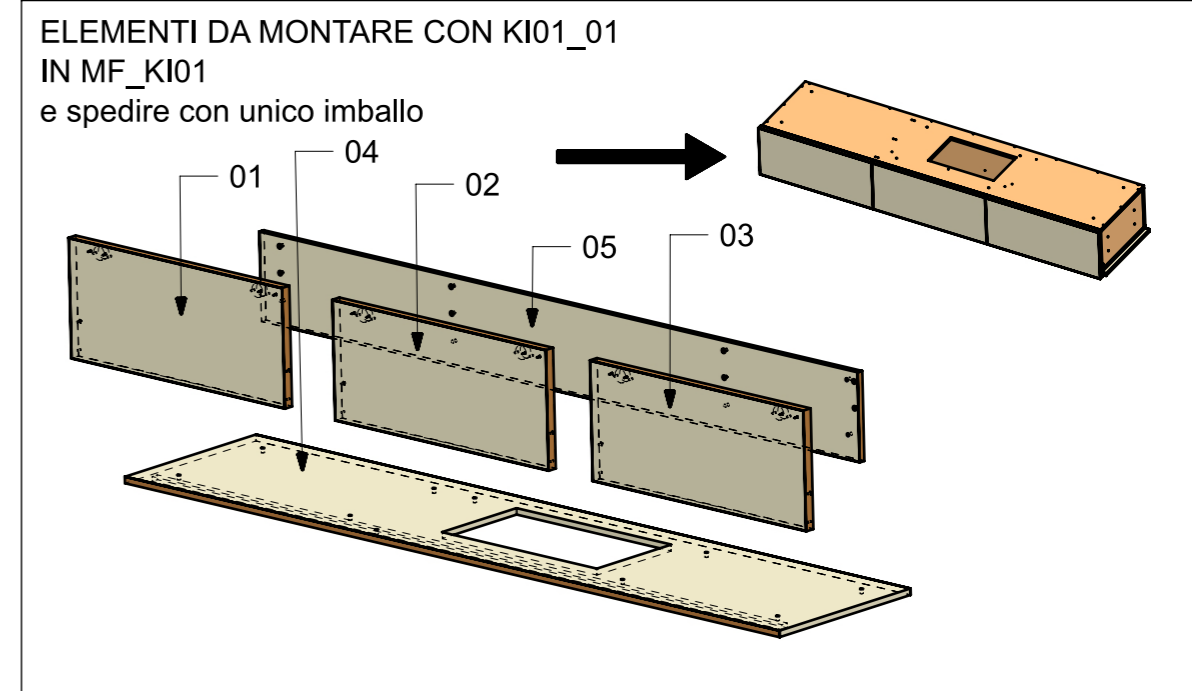
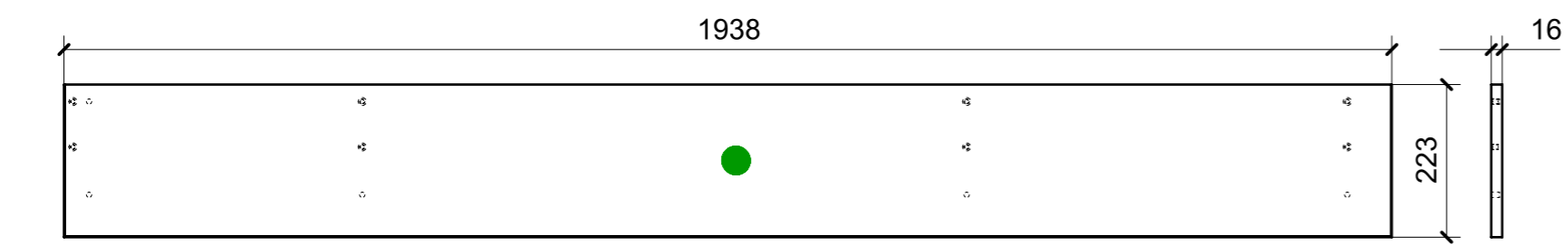
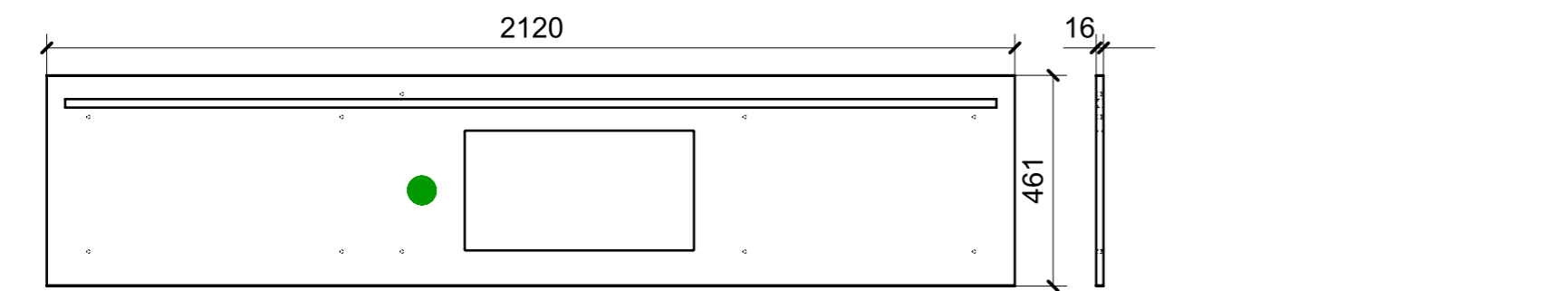
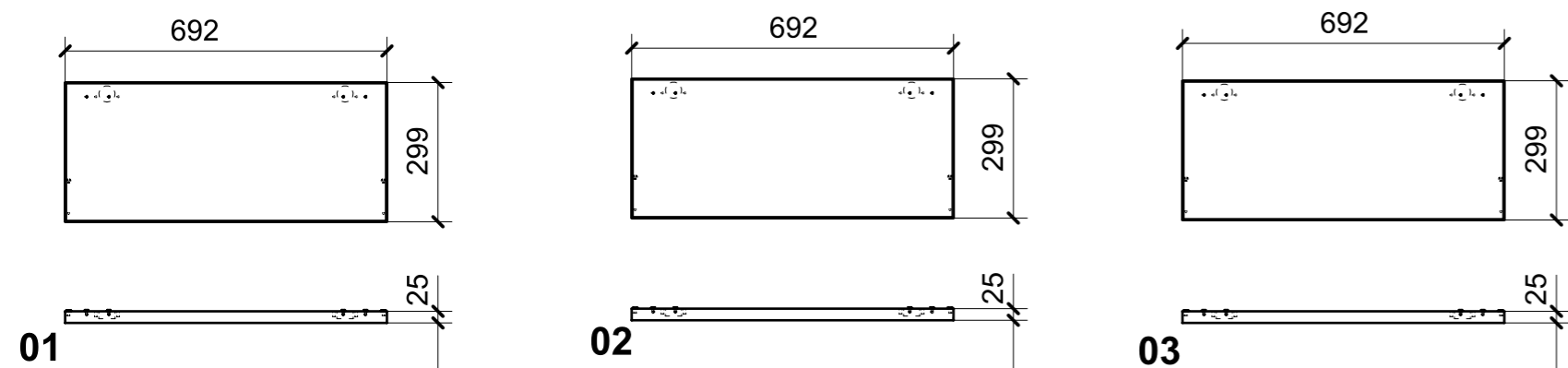
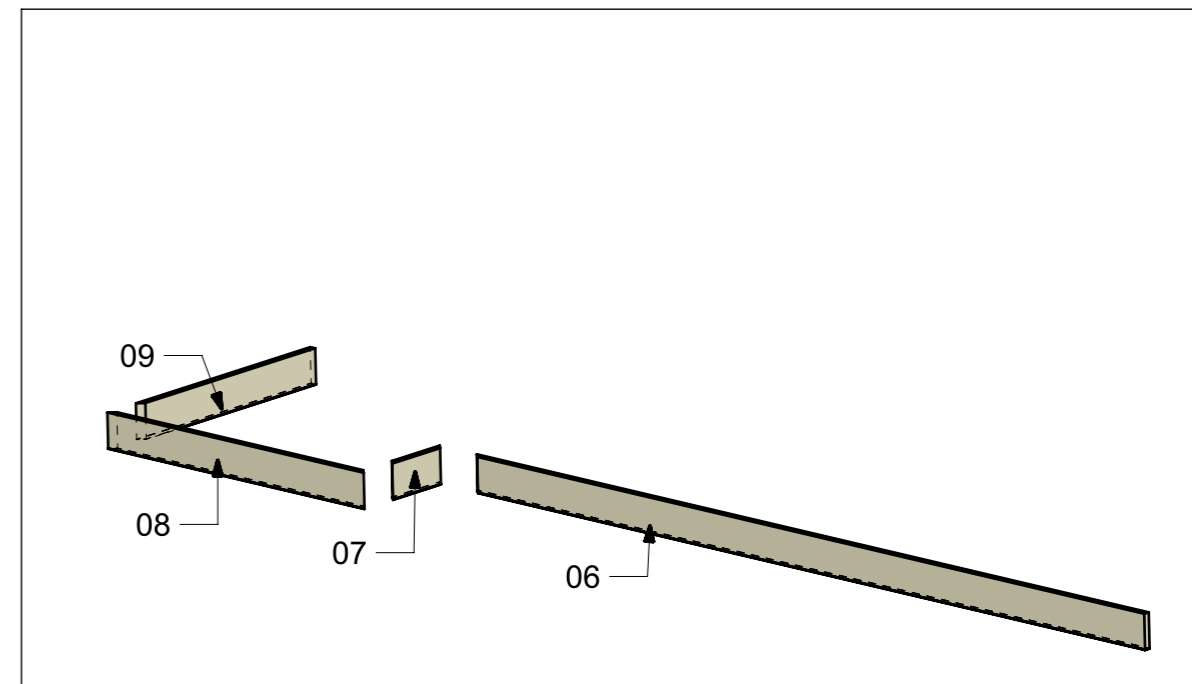
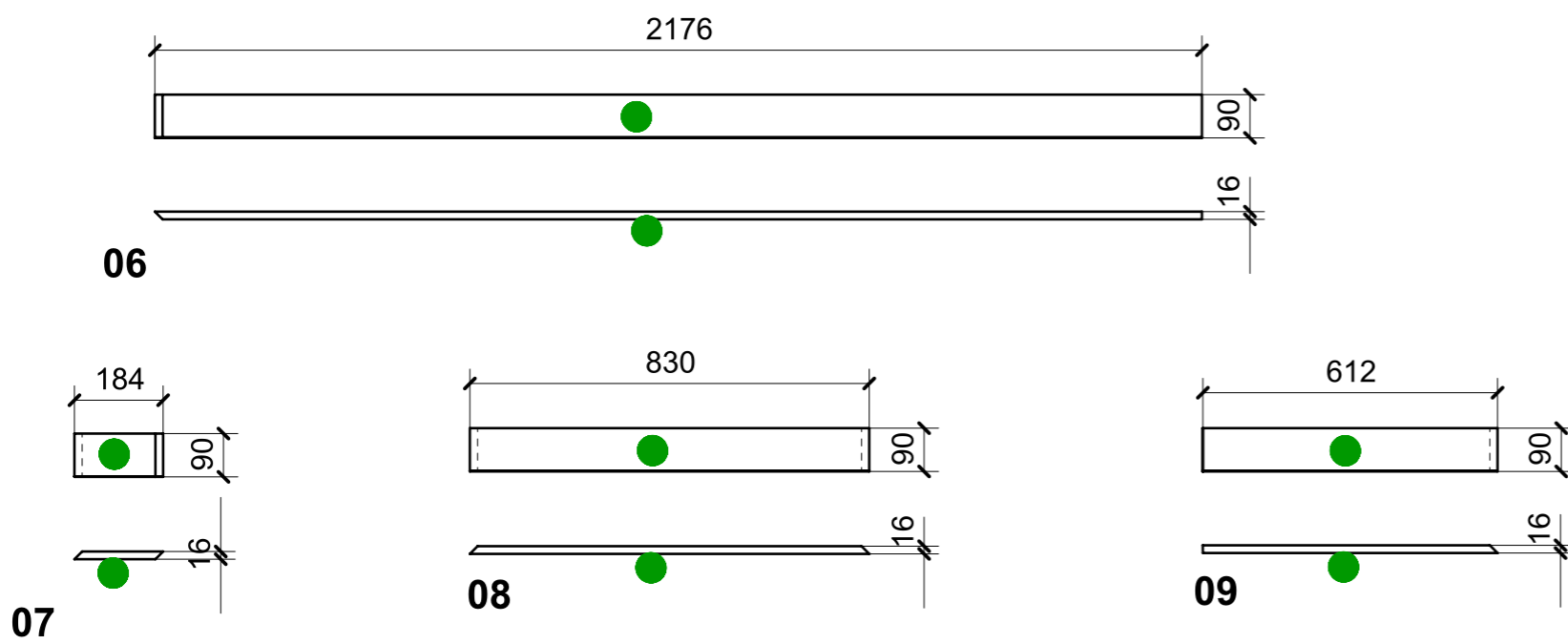

FERRAMENTA	QTY
BUSSOLA 6MA X 10 FORO DIAM.8	8
BUSSOLA 5MA ANKOR BORGHI X CERNIERA PIANA	12
VITE 4MAX8 ANKOR BORGHI X CERNIERA PIANA	12
GOMMINO PARACOLPO ANTA	6

VERNICIATURA LASTRA/LACCATI:  
● = VERNICIARE 1 LATO + FILI RASATI O BORDATI      NESSUN SIMBOLO = VERNICIARE 2 LATI + FILI RASATI O BORDATI

LOCALE	CODICE	DESCRIZIONE COMPONENTE	FINITURA	Q.TA
CUCINA APERTA	MD299_R01_KM01	RIV. COLONNA FINESTRINO	LASTRA SCURA	1

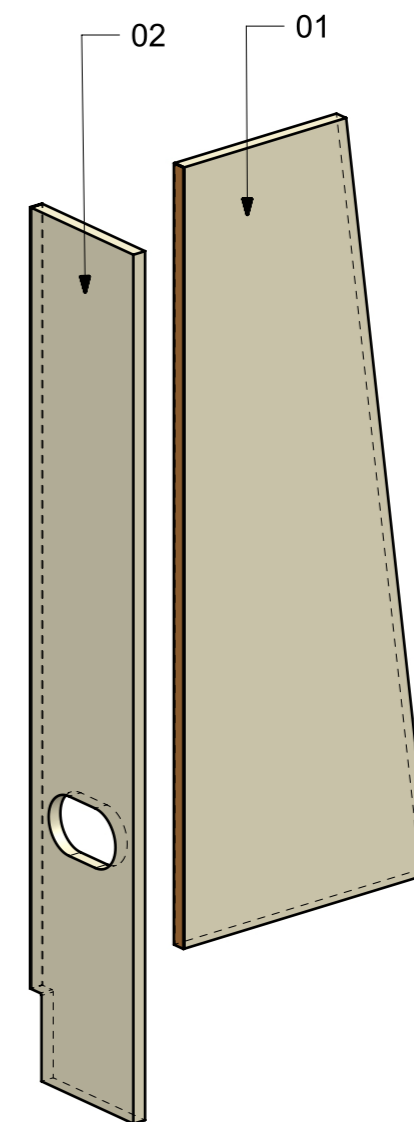
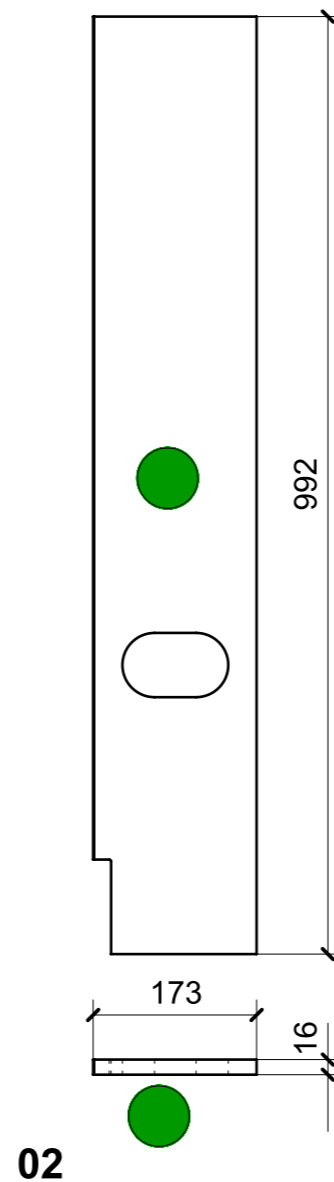
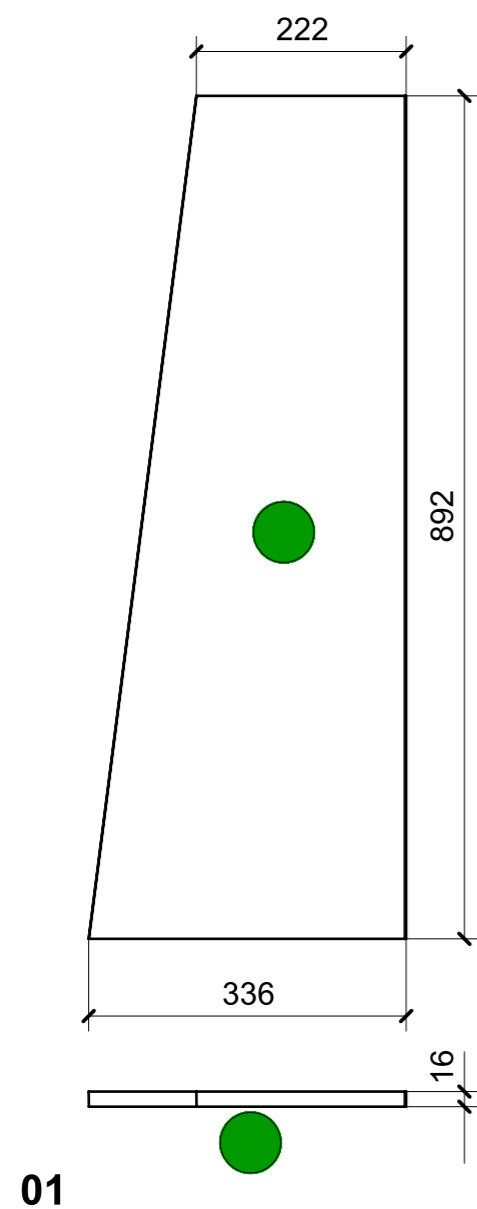

VERNICIATURA LASTRA/LACCATI:

● = VERNICIARE 1 LATO + FILI RASATI O BORDATI

NESSUN SIMBOLO = VERNICIARE 2 LATI + FILI RASATI O BORDATI

LOCALE	CODICE	DESCRIZIONE COMPONENTE	FINITURA	Q.TA
CUCINA APERTA	MD299_R01_KN01	RIV. PARETE DIVISORIA ZONA DINETTE_STD VAR 1	LASTRA SCURA	1

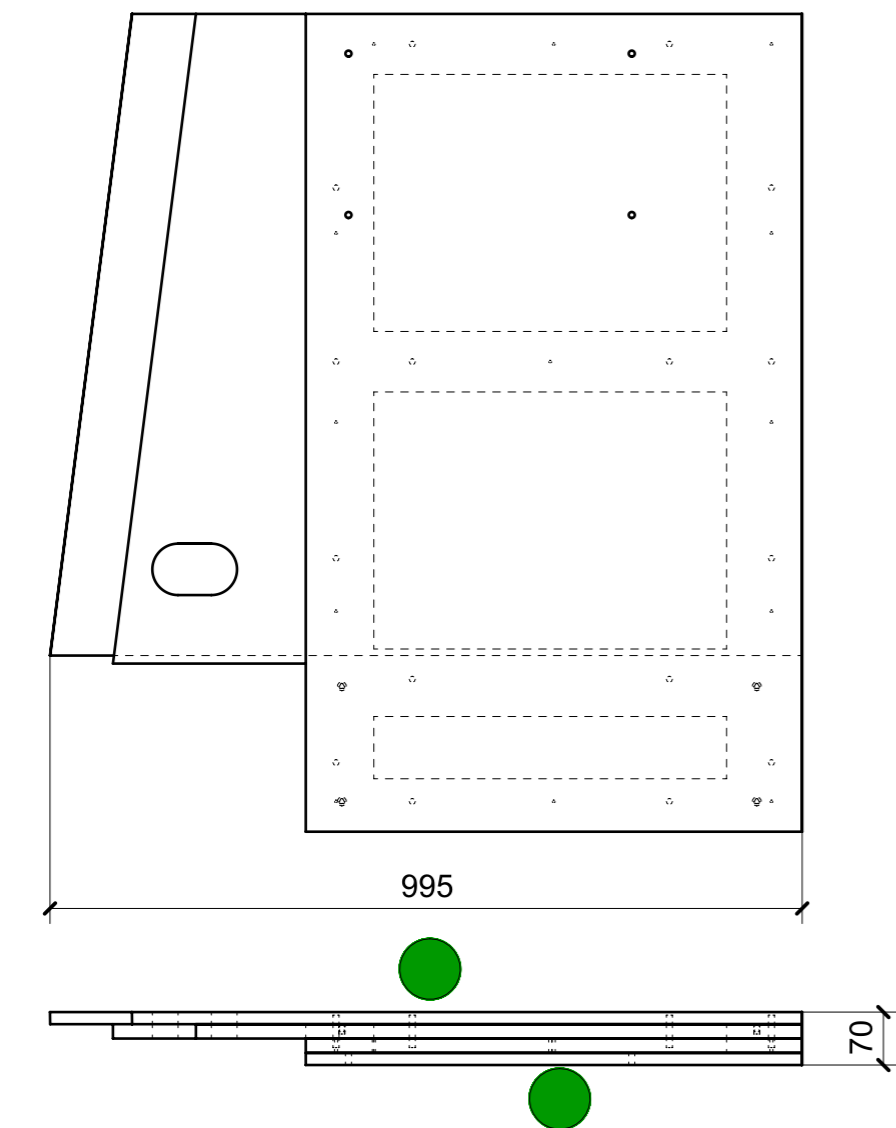

01

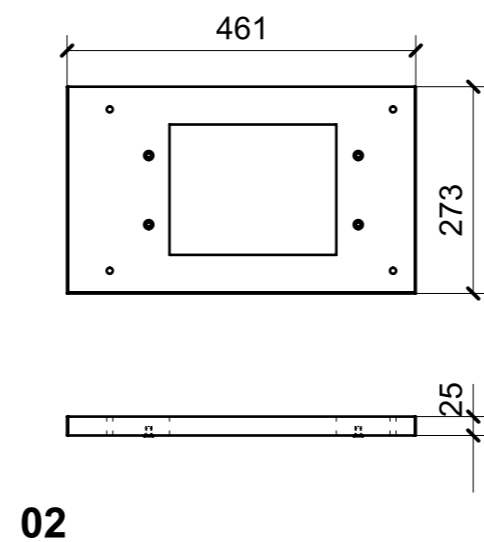

02

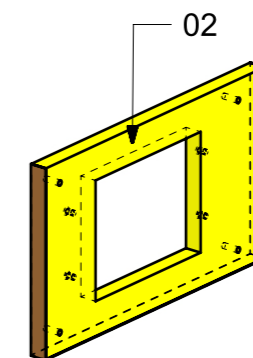

02

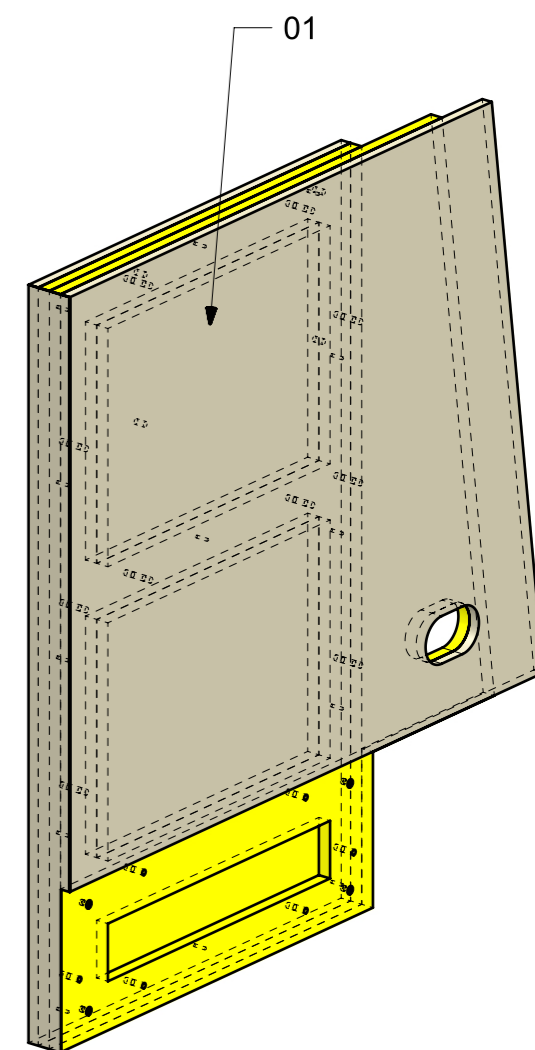

01

FERRAMENTA	QTY
BUSSOLA 6MA X 10 FORO DIAM.8	8

VERNICIATURA LASTRA/LACCATI:

● = VERNICIARE 1 LATO + FILI RASATI O BORDATI

NESSUN SIMBOLO = VERNICIARE 2 LATI + FILI RASATI O BORDATI

LOCALE	CODICE	DESCRIZIONE COMPONENTE	FINITURA	Q.TA
CUCINA CHIUSA	MD299_R01_KKN01	RIV. PARETE DIVISORIA ZONA DINETTE_STD VAR 2	LASTRA SCURA	1

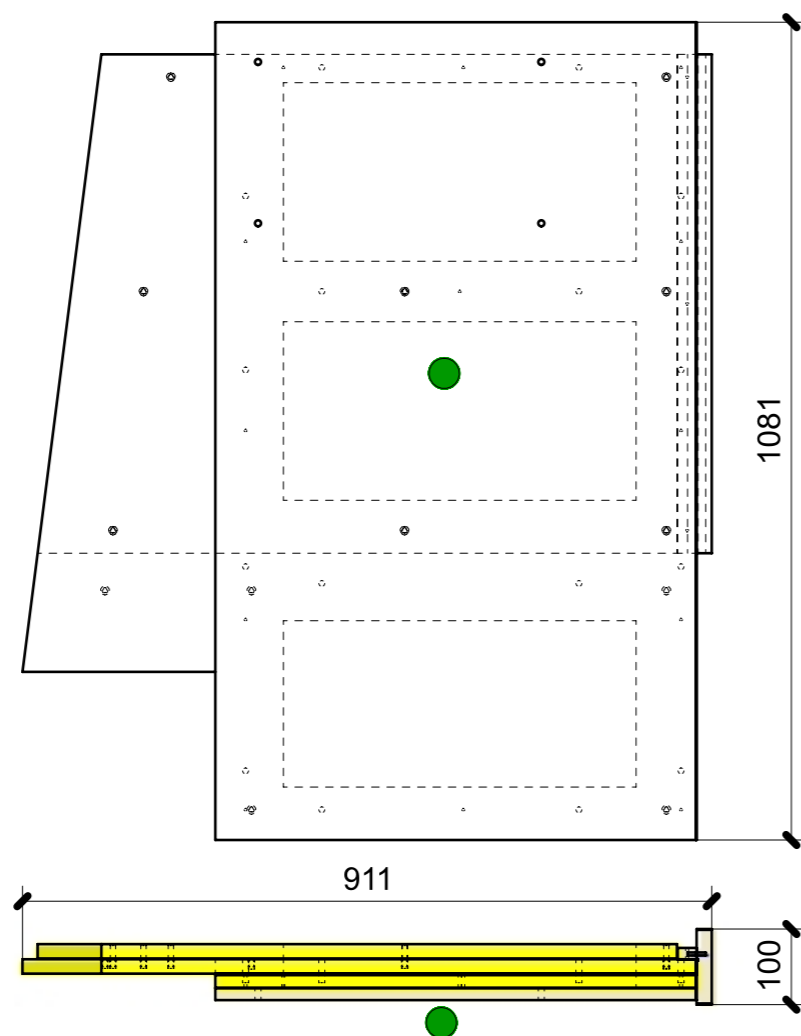
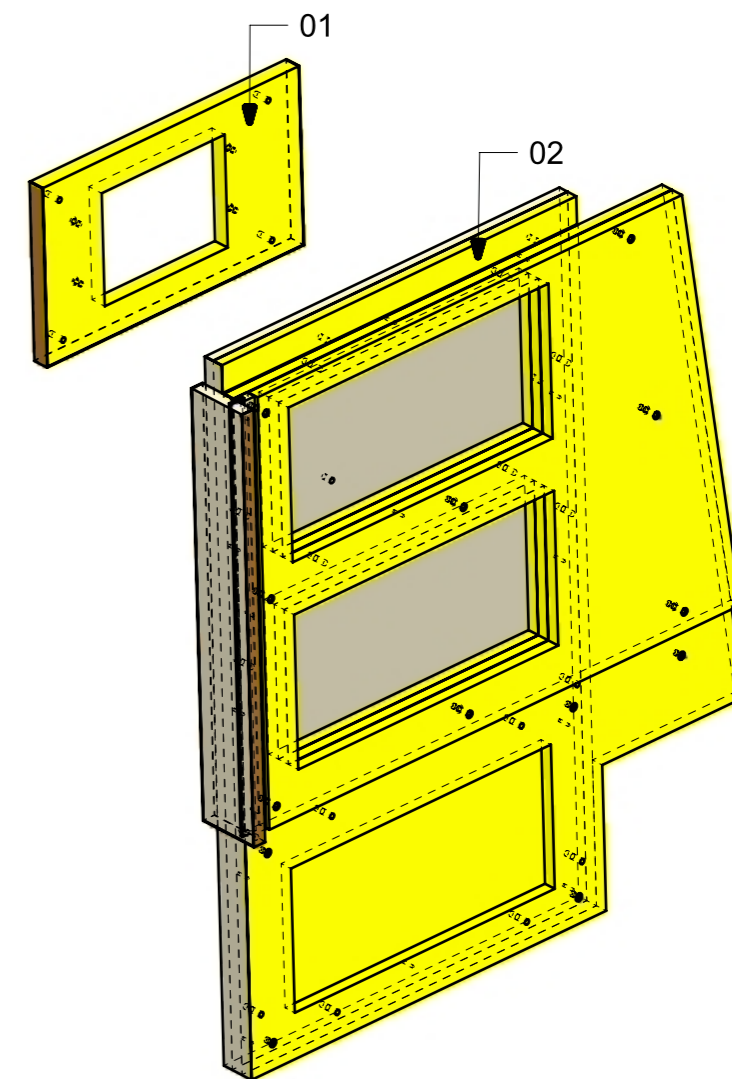
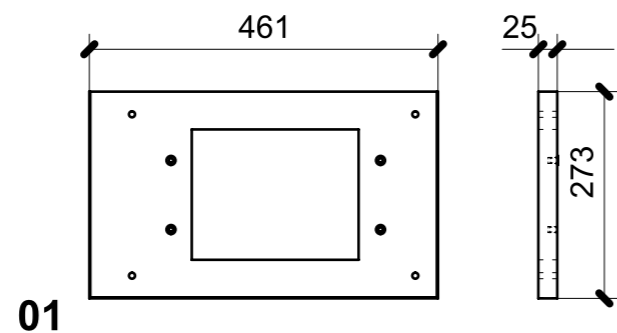

FERRAMENTA	QTY
BUSSOLA 6MA X 10 FORO DIAM.8	17

VERNICIATURA LASTRA/LACCATI:

● = VERNICIARE 1 LATO + FILI RASATI O BORDATI

NESSUN SIMBOLO = VERNICIARE 2 LATI + FILI RASATI O BORDATI

LOCALE	CODICE	DESCRIZIONE COMPONENTE	FINITURA	Q.TA
CUCINA APERTA	MD299_R01_KQ01	FIANCO BASE CUCINA_STD VAR 1	LASTRA SCURA	1

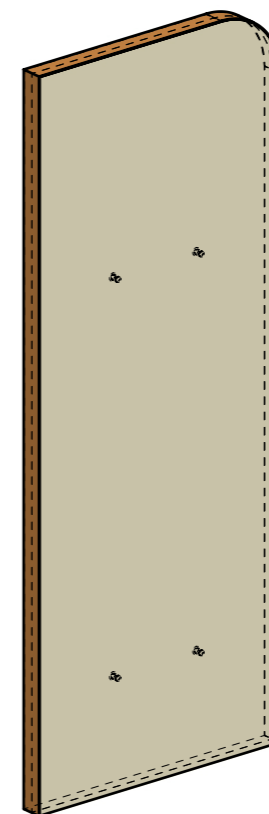
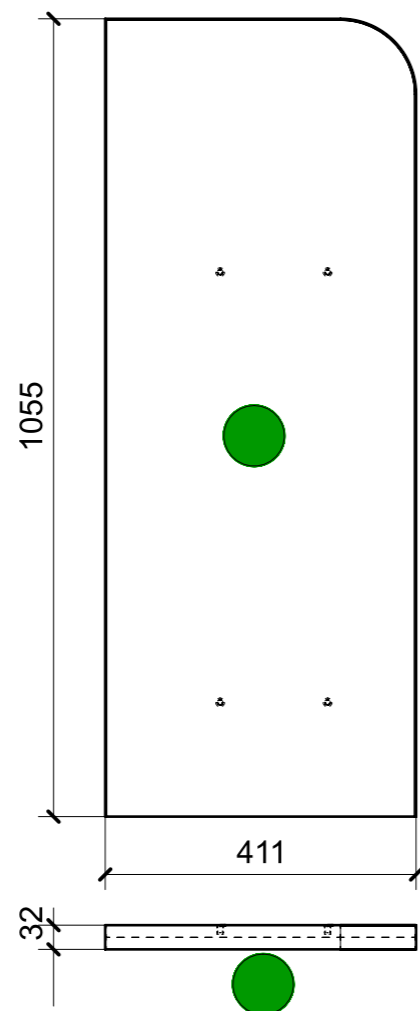

FERRAMENTA	QTY
BUSSOLA 6MA X 10 FORO DIAM.8	4

VERNICIATURA LASTRA/LACCATI:

● = VERNICIARE 1 LATO + FILI RASATI O BORDATI

NESSUN SIMBOLO = VERNICIARE 2 LATI + FILI RASATI O BORDATI

LOCALE	CODICE	DESCRIZIONE COMPONENTE	FINITURA	Q.TA
CUCINA APERTA	MD299_R01_KKQ01	FIANCO BASE CUCINA_STD VAR 2	LASTRA SCURA	1

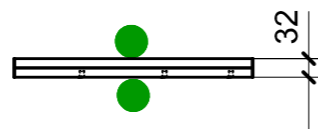
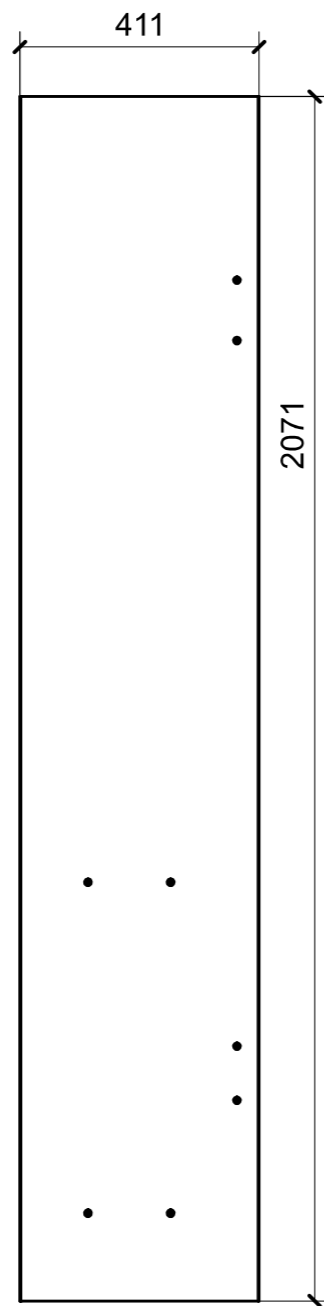

ELEMENTO DA MONTARE CON A66 IN MF\_KKQ01  
e spedire con unico imballo

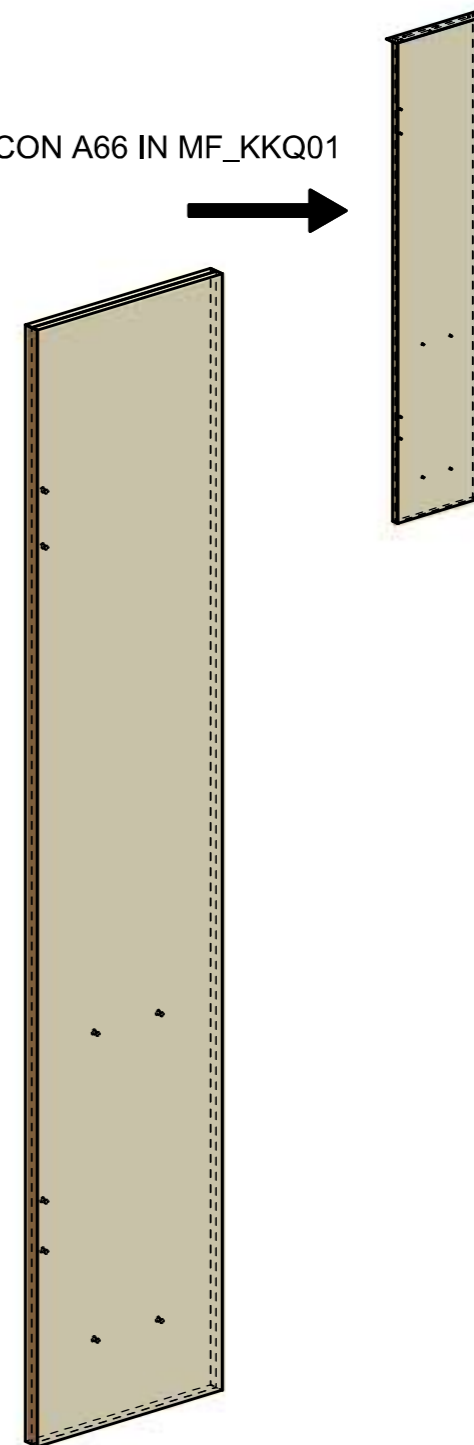

FERRAMENTA	QTY
BUSSOLA 6MA X 10 FORO DIAM.8	8

VERNICIATURA LASTRA/LACCATI:

● = VERNICIARE 1 LATO + FILI RASATI O BORDATI

NESSUN SIMBOLO = VERNICIARE 2 LATI + FILI RASATI O BORDATI

LOCALE	CODICE	DESCRIZIONE COMPONENTE	FINITURA	Q.TA
CUCINA APERTA	MD299_R01_KKR01	LAMELLE CENTRALI_STD VAR 2	LASTRA SCURA	1

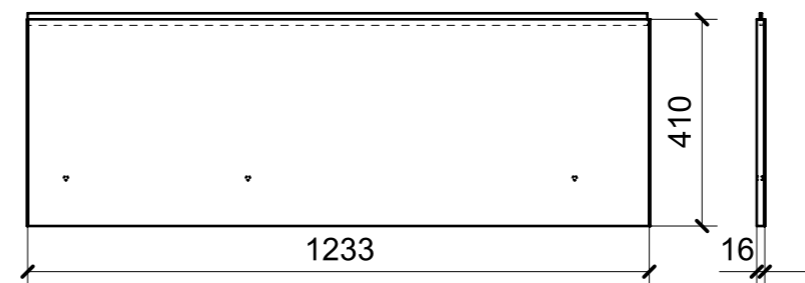
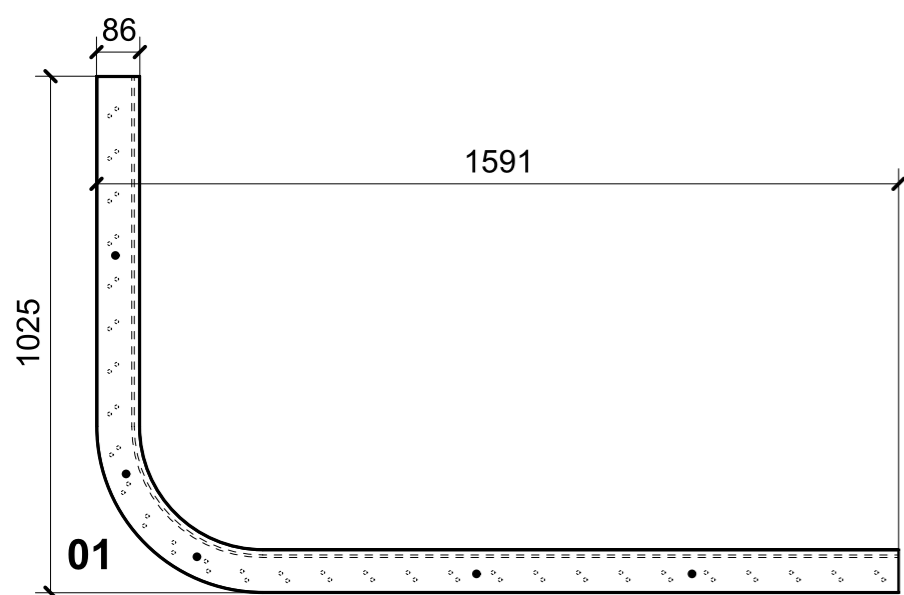

03

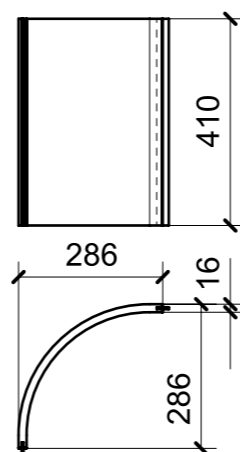
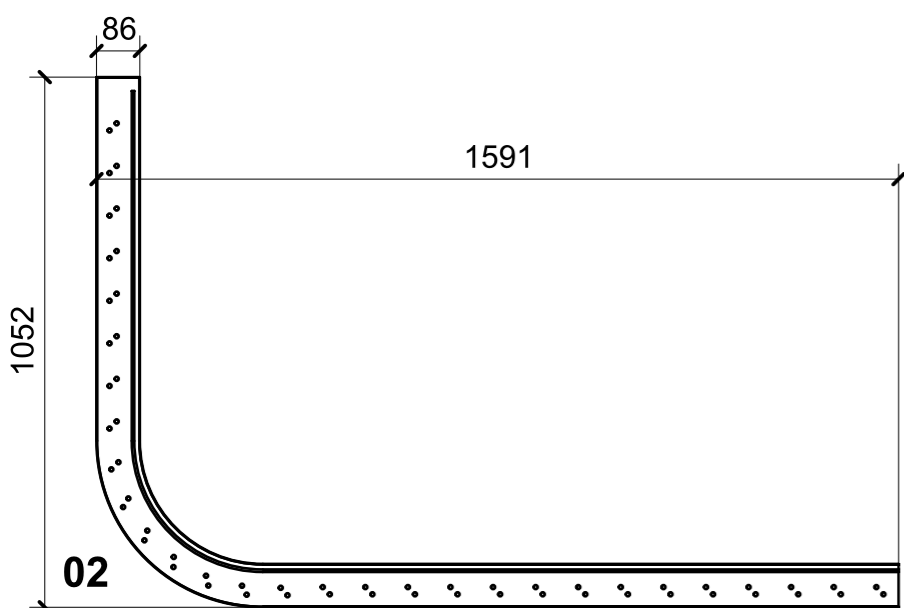
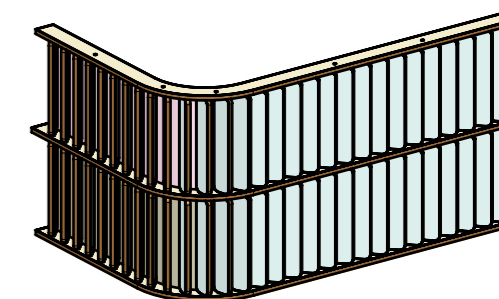

04

ELEMENTI DA MONTARE  
CON P01\_KKR01\_01 e X01\_KKR01\_01  
in MF\_KKR01  
e spedire con unico imballo

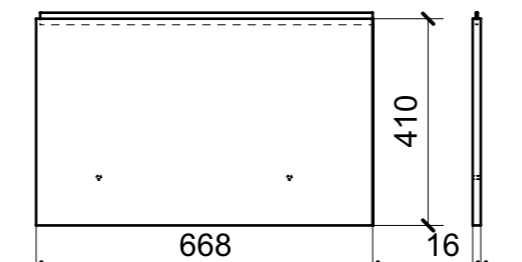
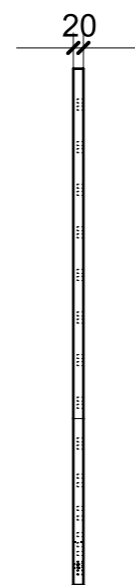
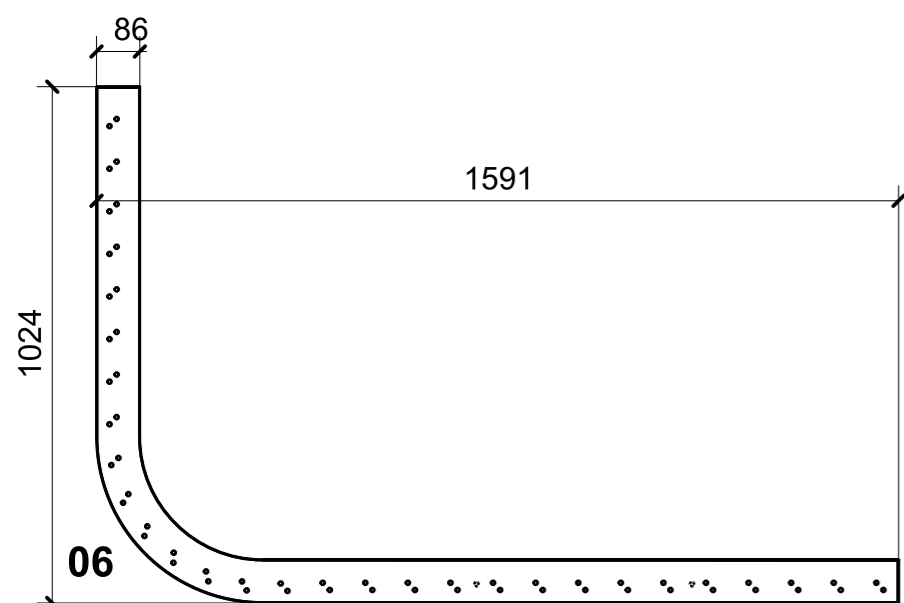

05

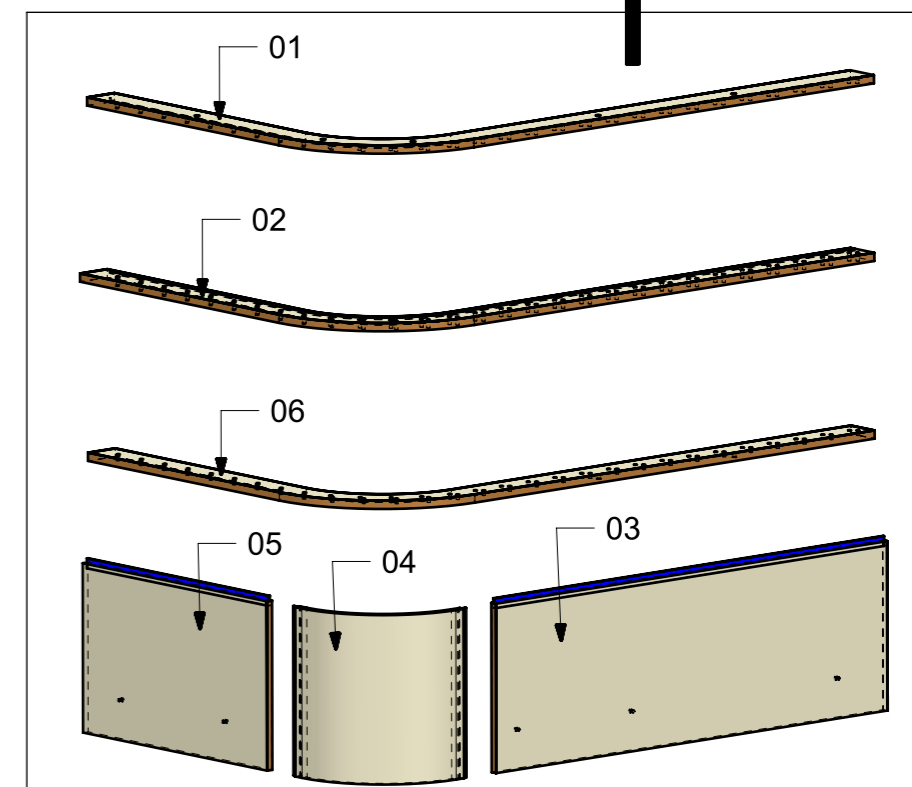

FERRAMENTA	QTY
BUSSOLA 6MA X 10 FORO DIAM.8	12

VERNICIATURA LASTRA/LACCATI:

● = VERNICIARE 1 LATO + FILI RASATI O BORDATI

NESSUN SIMBOLO = VERNICIARE 2 LATI + FILI RASATI O BORDATI

LOCALE	CODICE	DESCRIZIONE COMPONENTE	FINITURA	Q.TA
CUCINA APERTA	MD299_R01_KKS01	CHIUSURA ALTA PRUA STD VAR 2	LASTRA SCURA	1

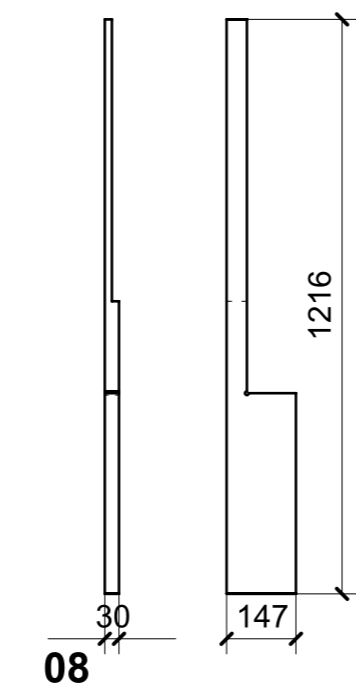
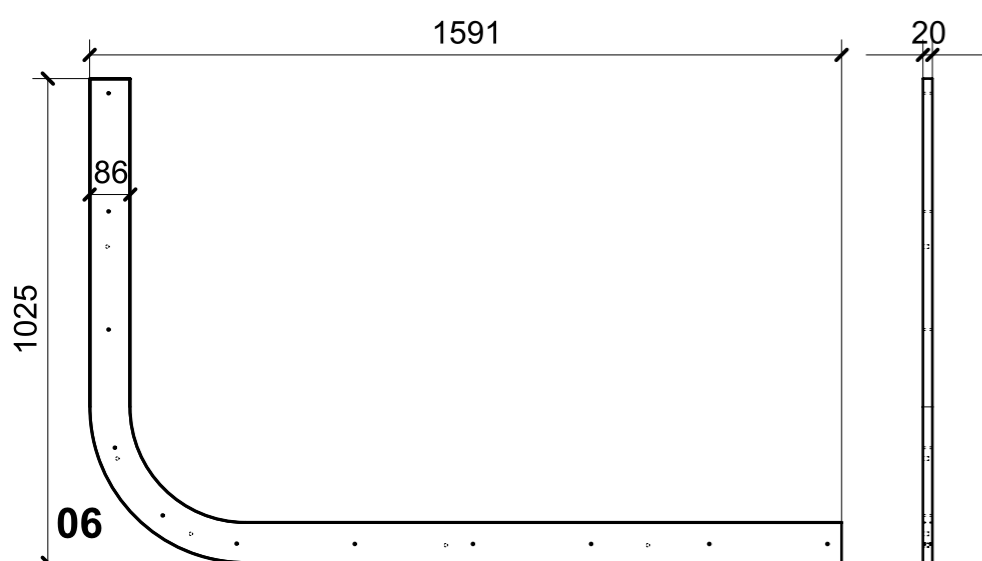
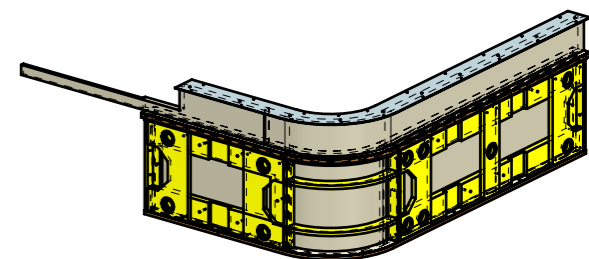
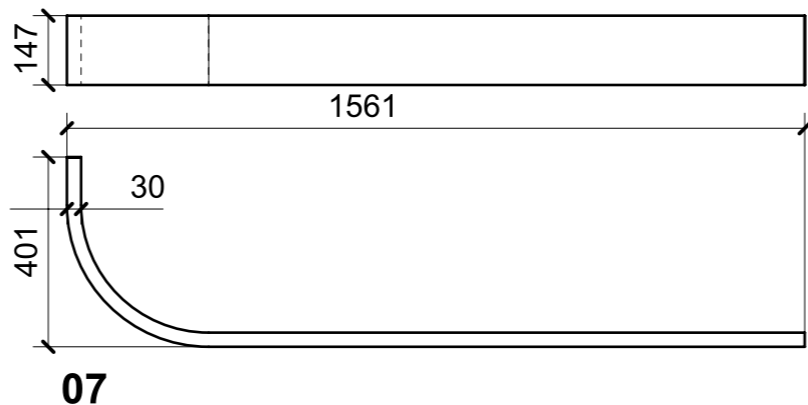
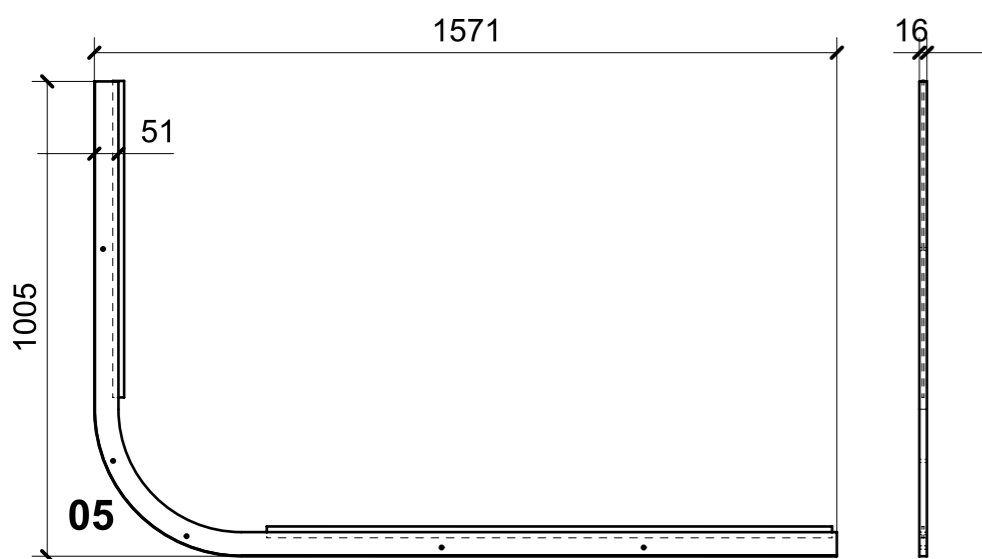
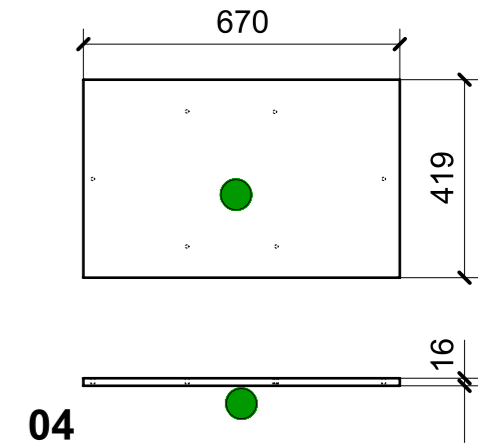
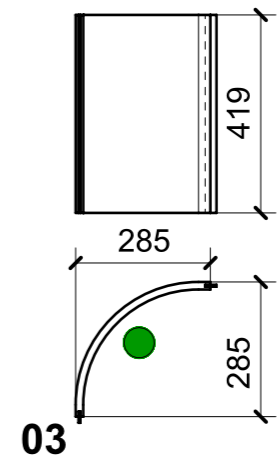
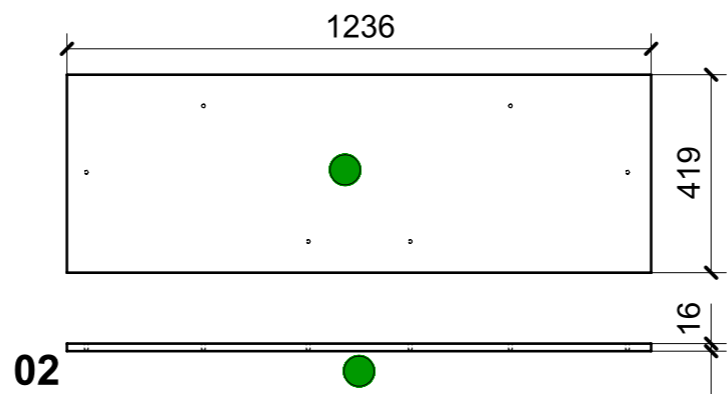
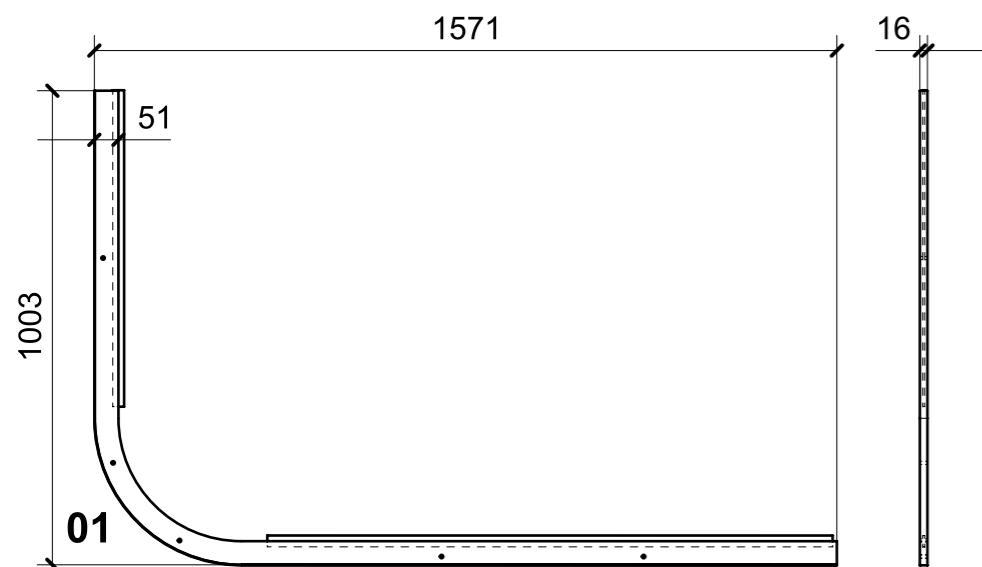

ELEMENTI DA MONTARE CON A67, KKS01\_01/03  
in MF\_KKS01  
e spedire con unico imballo

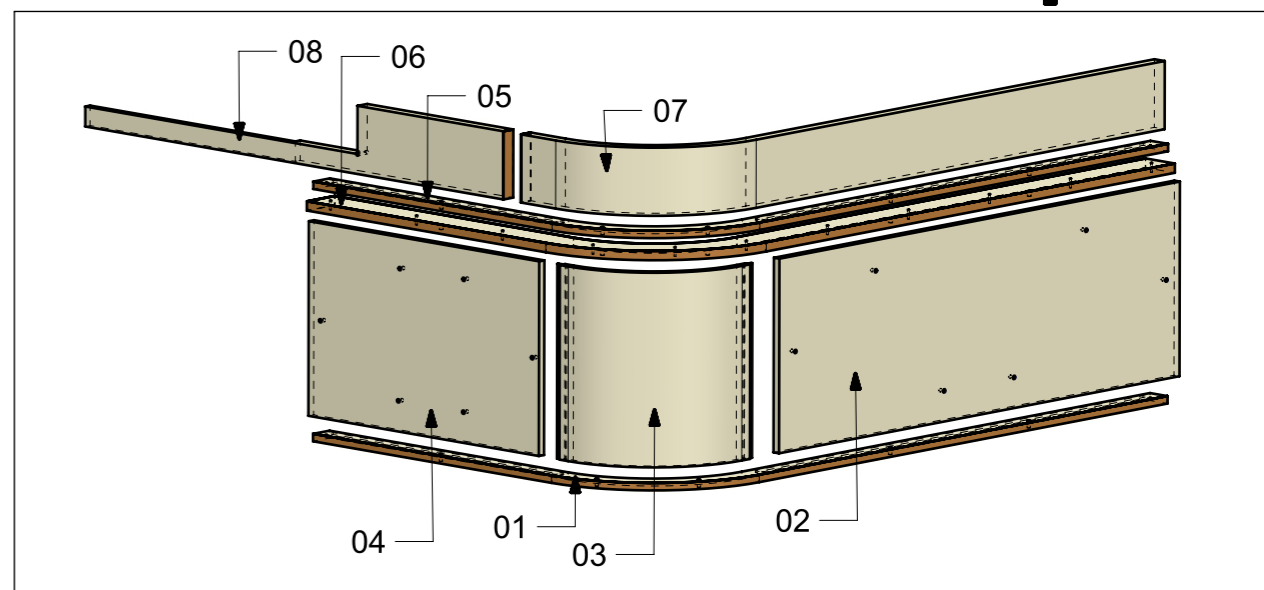

VERNICIATURA LASTRA/LACCATI:

● = VERNICIARE 1 LATO + FILI RASATI O BORDATI

NESSUN SIMBOLO = VERNICIARE 2 LATI + FILI RASATI O BORDATI

LOCALE	CODICE	DESCRIZIONE COMPONENTE	FINITURA	Q.TA
CUCINA APERTA	MD299_R01_KKT01	CHIUSURA ALTA POPPA_STD VAR 2	LASTRA SCURA	1

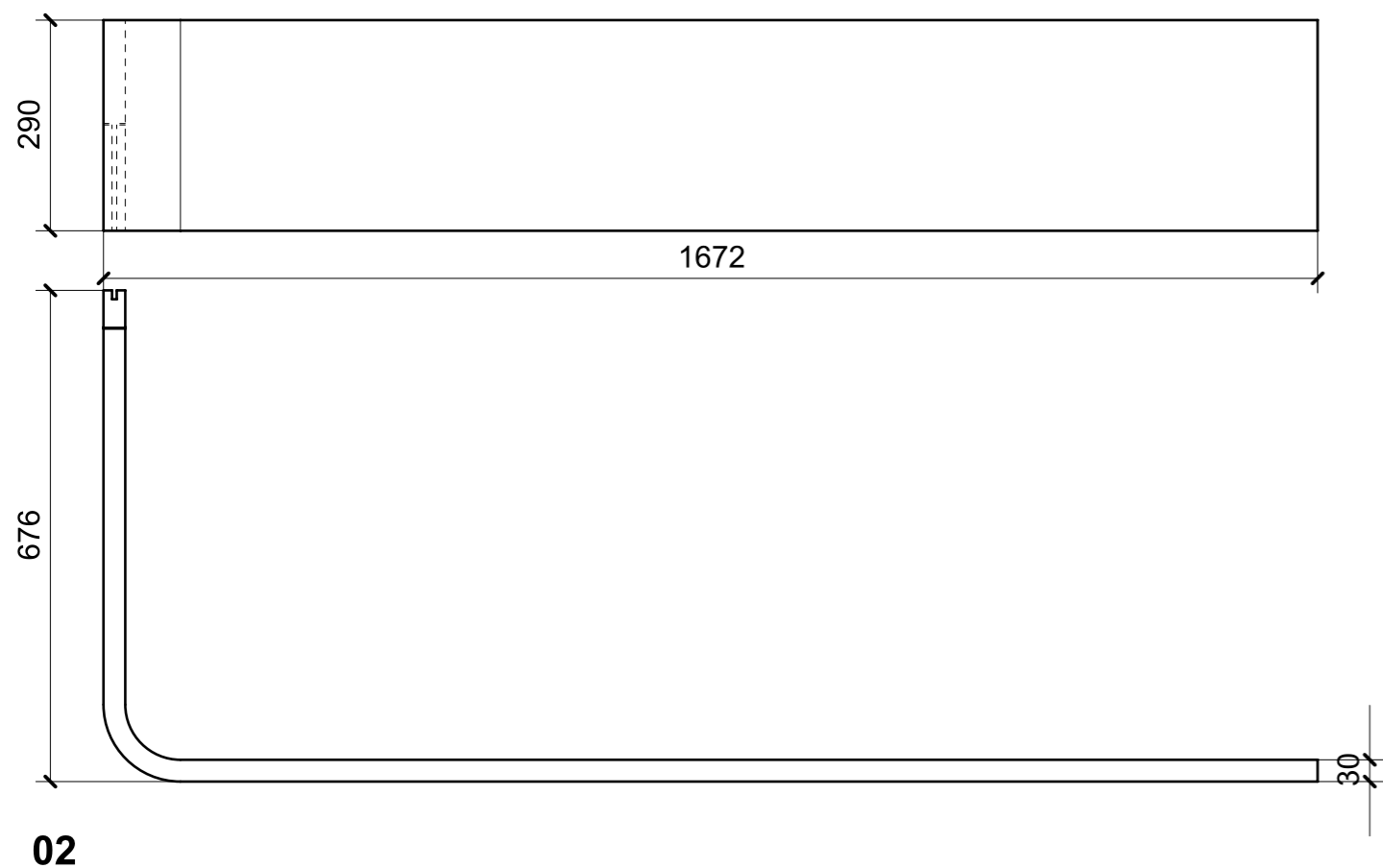
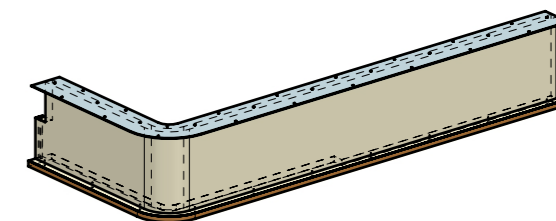
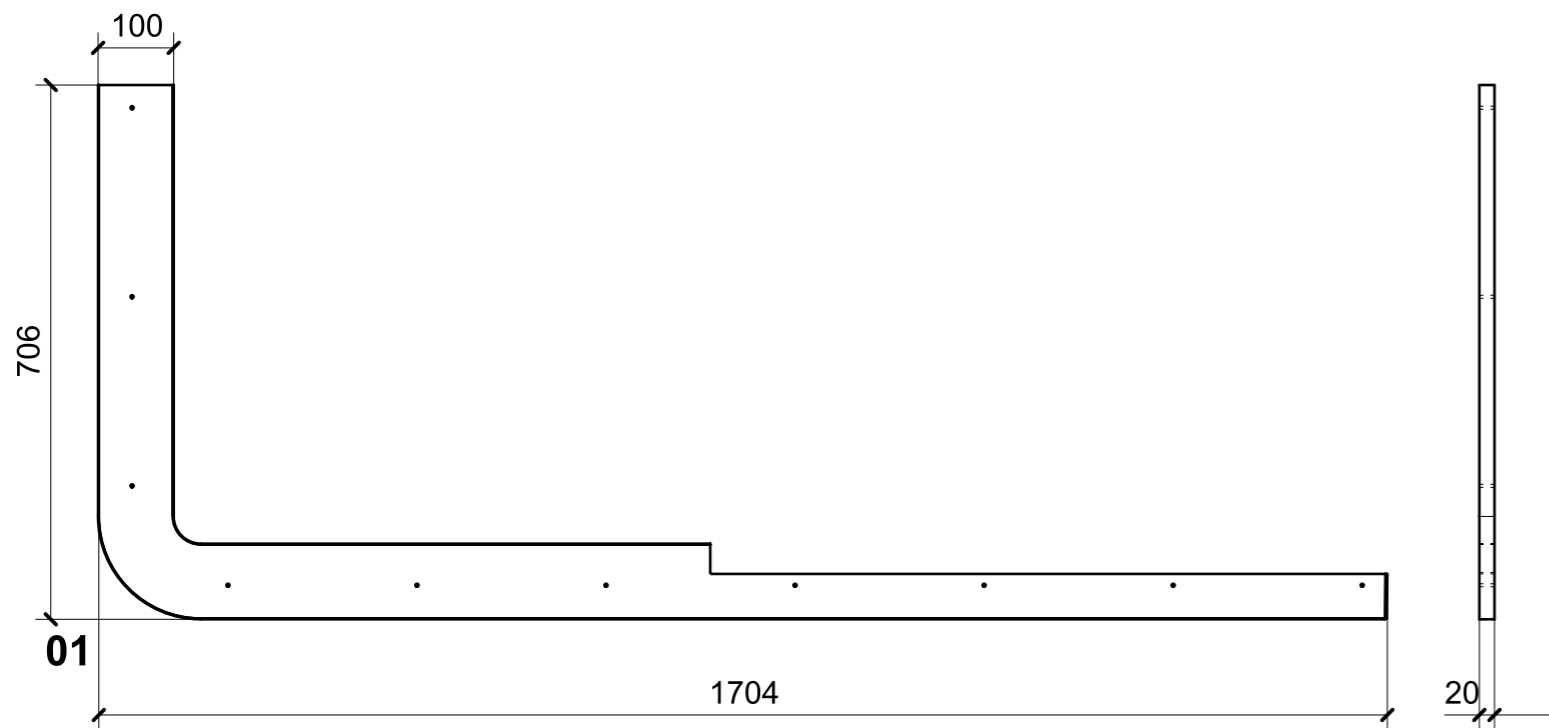

ELEMENTI DA MONTARE CON A68 IN MF\_KKT01  
e spedire con unico imballo

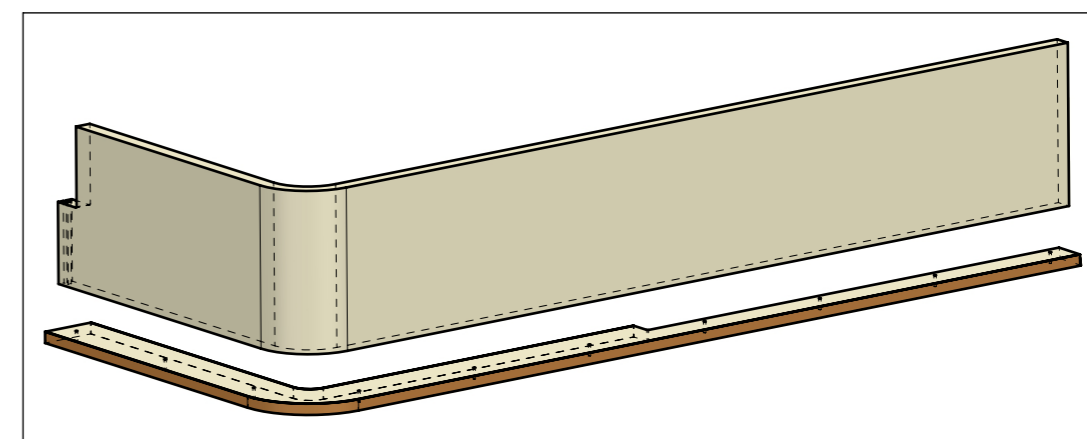

VERNICIATURA LASTRA/LACCATI:

● = VERNICIARE 1 LATO + FILI RASATI O BORDATI

NESSUN SIMBOLO = VERNICIARE 2 LATI + FILI RASATI O BORDATI

LOCALE	CODICE	DESCRIZIONE COMPONENTE	FINITURA	Q.TA
CUCINA APERTA	MD299_R01_KKX01	FIANCO PORTA PRUA_STD VAR 2	LASTRA SCURA	1

ELEMENTO DA MONTARE CON A71 IN MF\_KKX01\_01  
e spedire con unico imballo

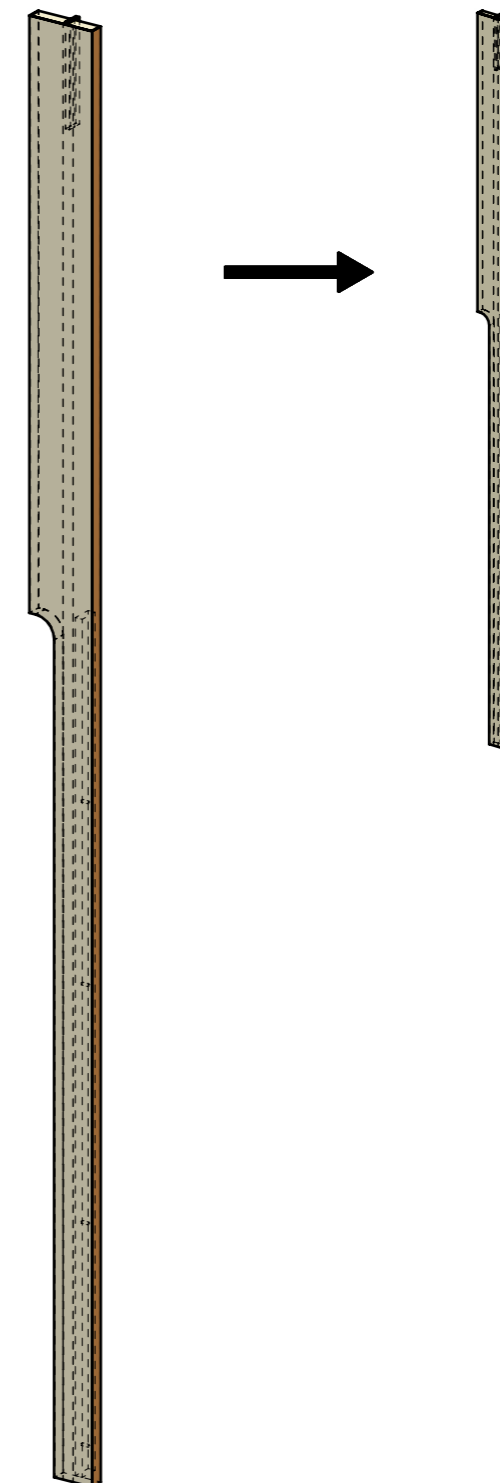
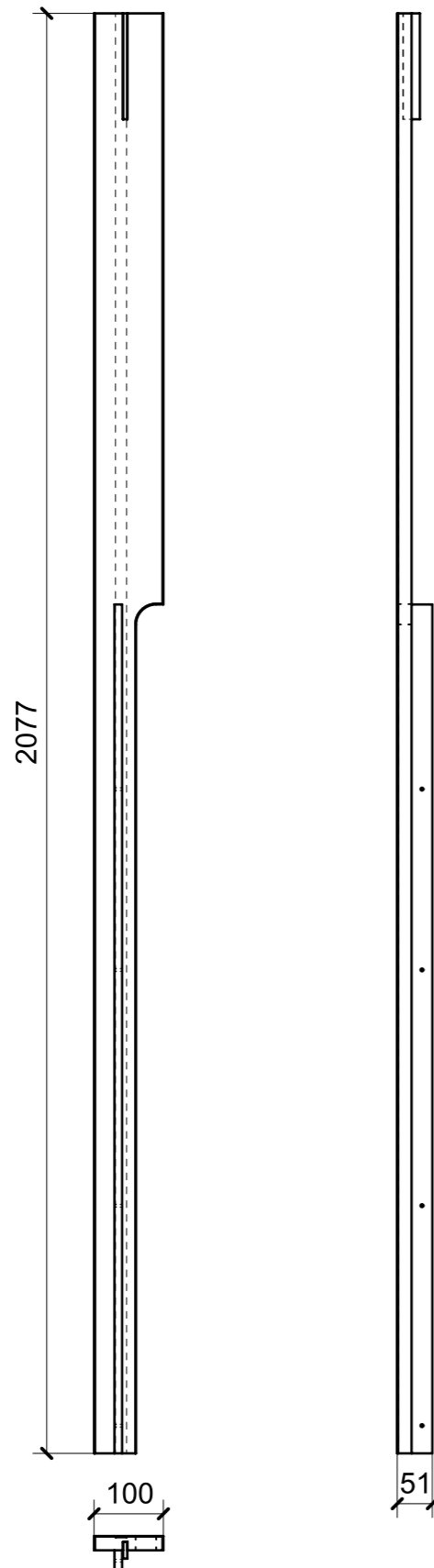

VERNICIATURA LASTRA/LACCATI:

● = VERNICIARE 1 LATO + FILI RASATI O BORDATI

NESSUN SIMBOLO = VERNICIARE 2 LATI + FILI RASATI O BORDATI