

LOCALE	CODICE	DESCRIZIONE COMPONENTE	FINITURA	GR
CABINA ARMATORE	MD299_R01_AA01	ARMADIO SX PRUA	LASTRA SCURA	16

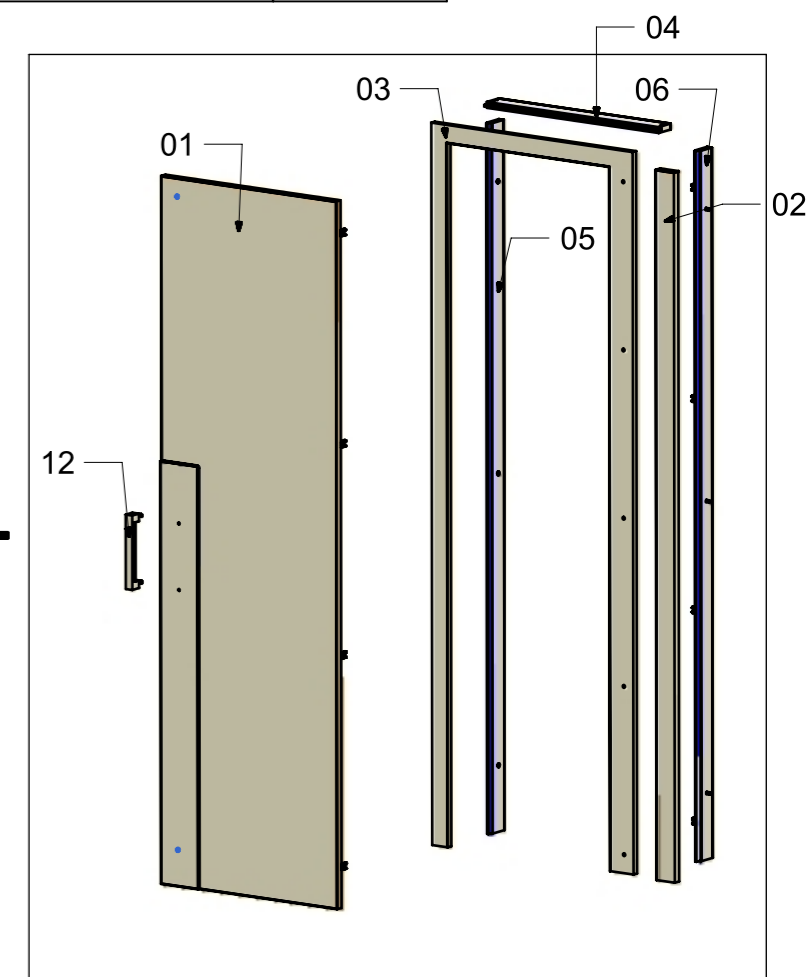

ELEMENTI DA MONTARE CON A01
IN MF_AA01
e spedire con unico imballo

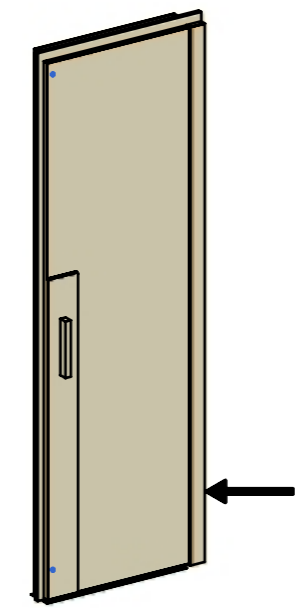
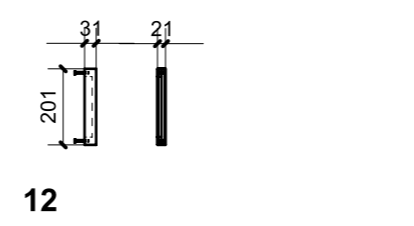
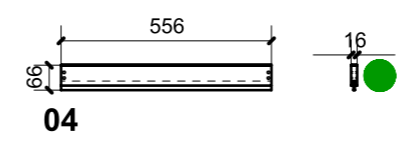
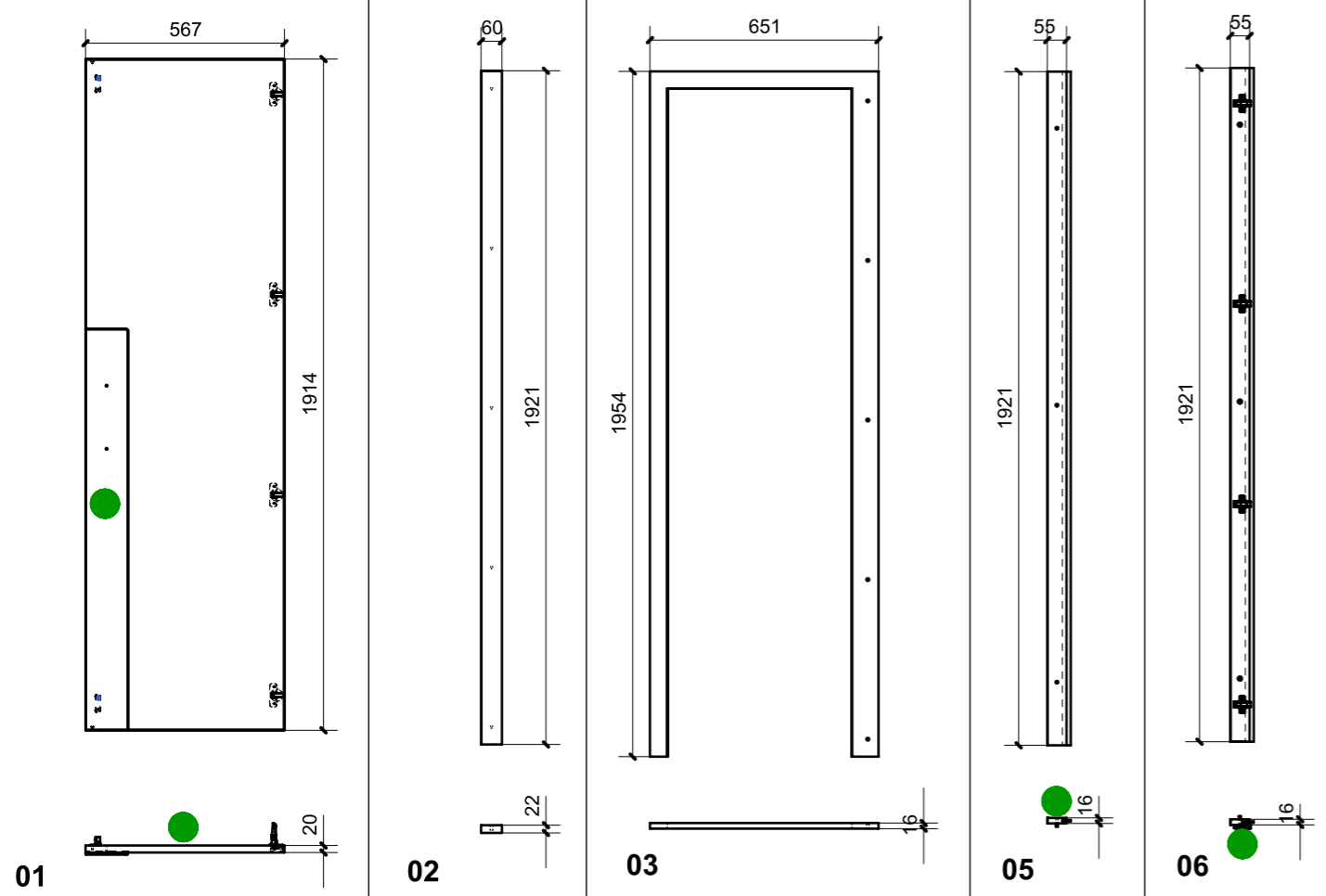
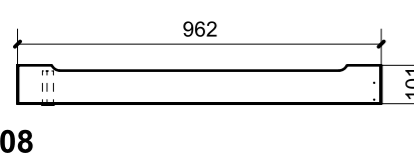
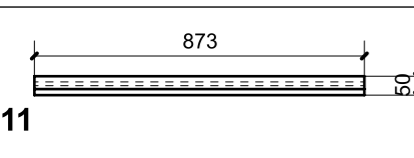
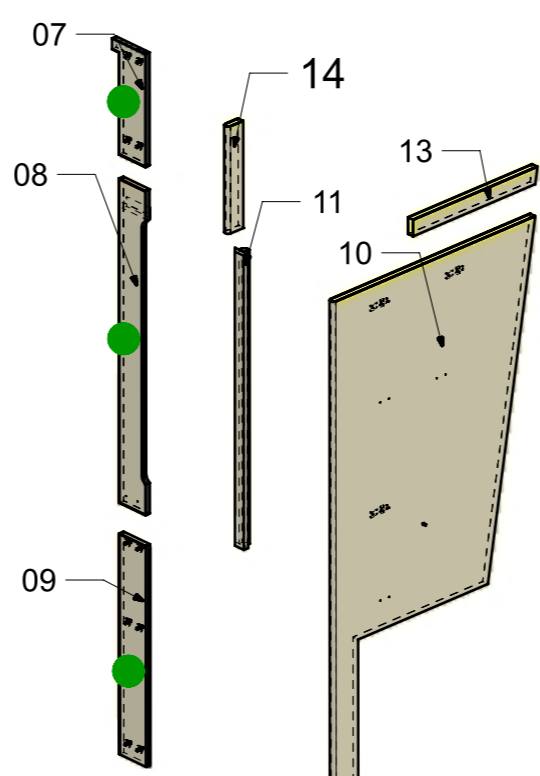
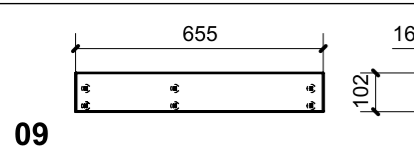
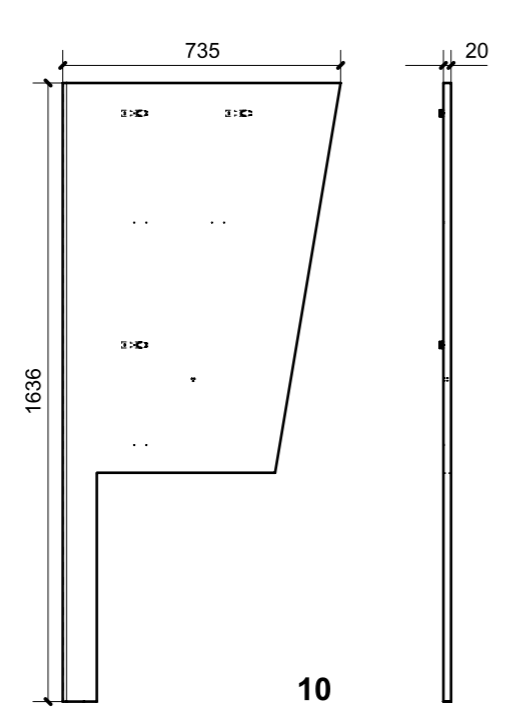
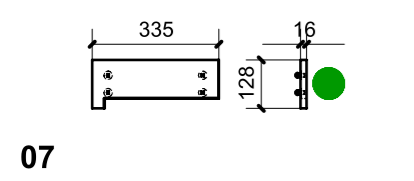
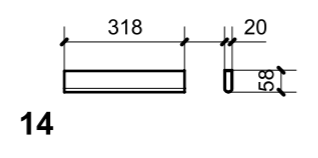
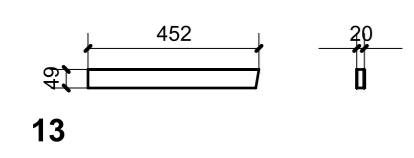

FERRAMENTA	QTY
BASE_6_HAFELE_329_84_026	4
BUSSOLA 4MA X 10 FORO DIAM.6	2
BUSSOLA 5MA ANKOR BORGHI X CERNIERA PIANA	16
BUSSOLA 6MA X 10 FORO DIAM.8	1
CALAMITA SEALED MAGNETIC_TECNOPARTNER_MC-JM50-BL	2
CERNIERA 94° PIANA AMMORTIZZATA_HAFELE_329_49_310	4
GOMMINO PARACOLPO ANTA	2
MS INCASSO_ITALVIPLA_972_FMPC_M1B	10
PARTE PANNELLO CON INCASTRO_HAFELE_262_49_356 AGG. INVERTITO	3
PLACCHETTA COUNTER STEEL_TECNOPARTNER_MC-JM49	2
VITE 4MA X 30 TESTA SVASATA ESAGONALE NERA	2
VITE 4MAX8 ANKOR BORGHI X CERNIERA PIANA	16
VITE 6MA X 25 TESTA SVASATA	6

VERNICIATURA LASTRA/LACCATI:
● = VERNICIARE 1 LATO + FILI RASATI O BORDATI
 NESSUN SIMBOLO = VERNICIARE 2 LATI + FILI RASATI O BORDATI

LOCALE	CODICE	DESCRIZIONE COMPONENTE	FINITURA	GR
CABINA ARMATORE	MD299_R01_AB01	STRUTTURA COLONNA SX	LASTRA SCURA	16

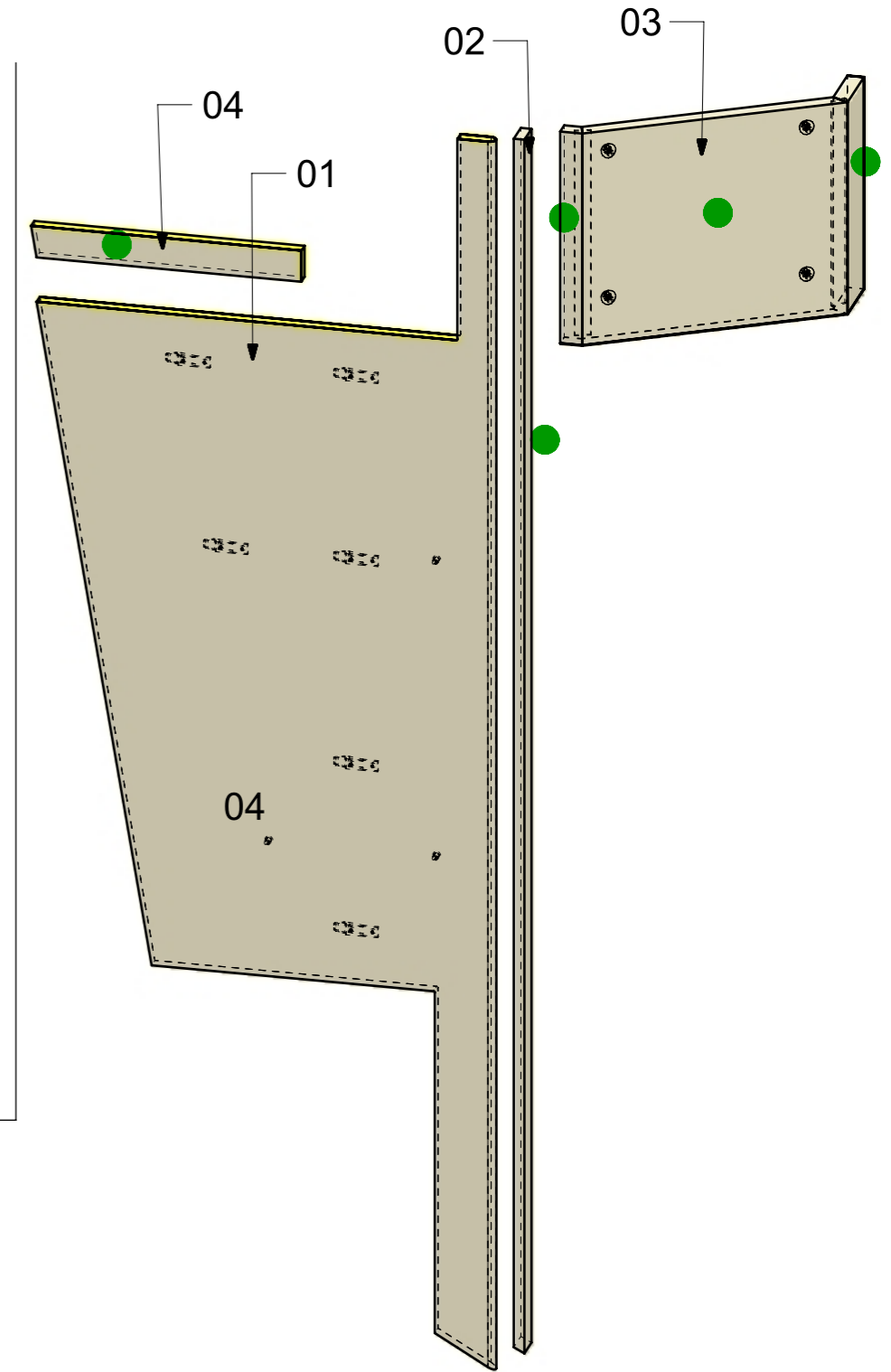
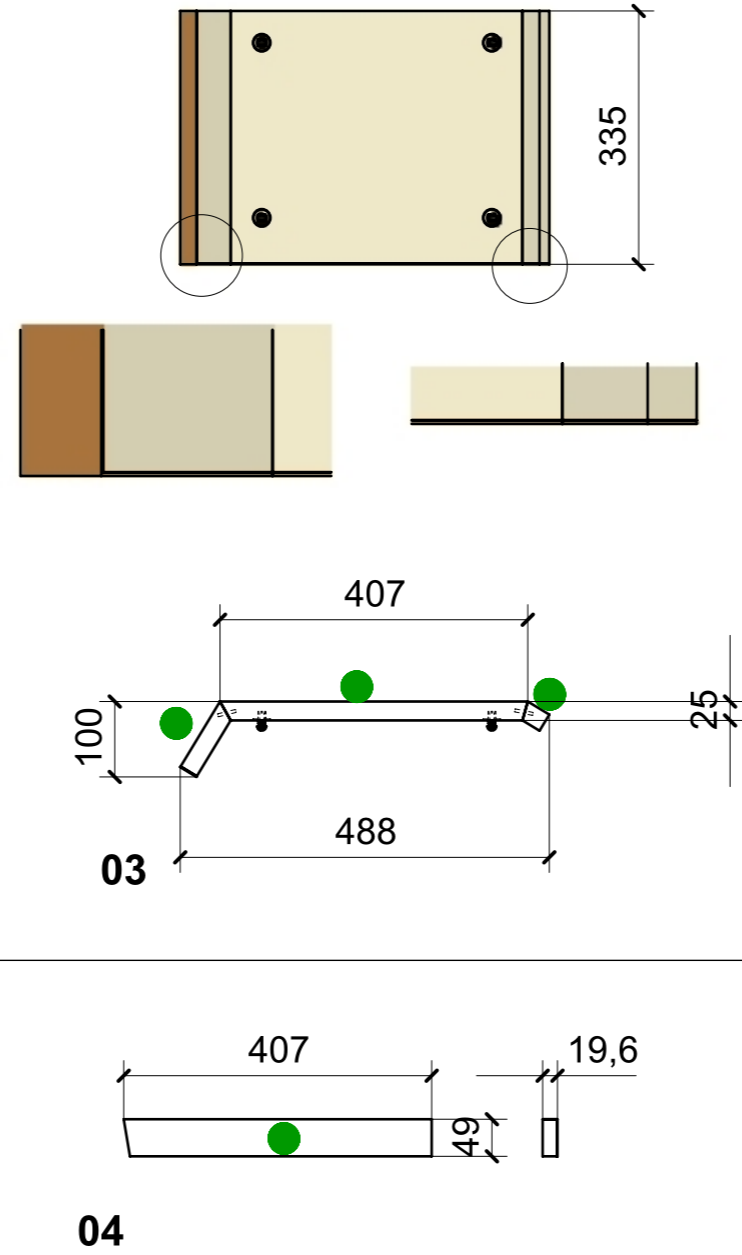
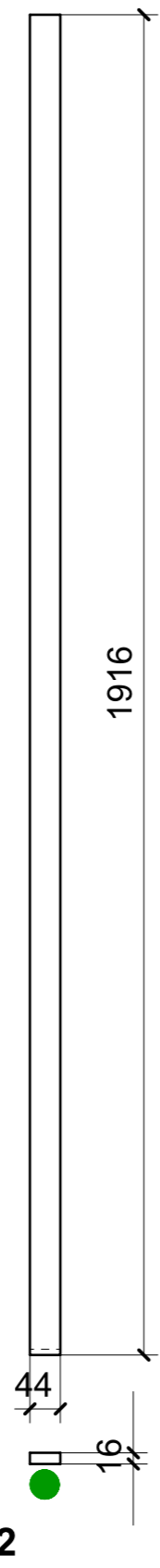
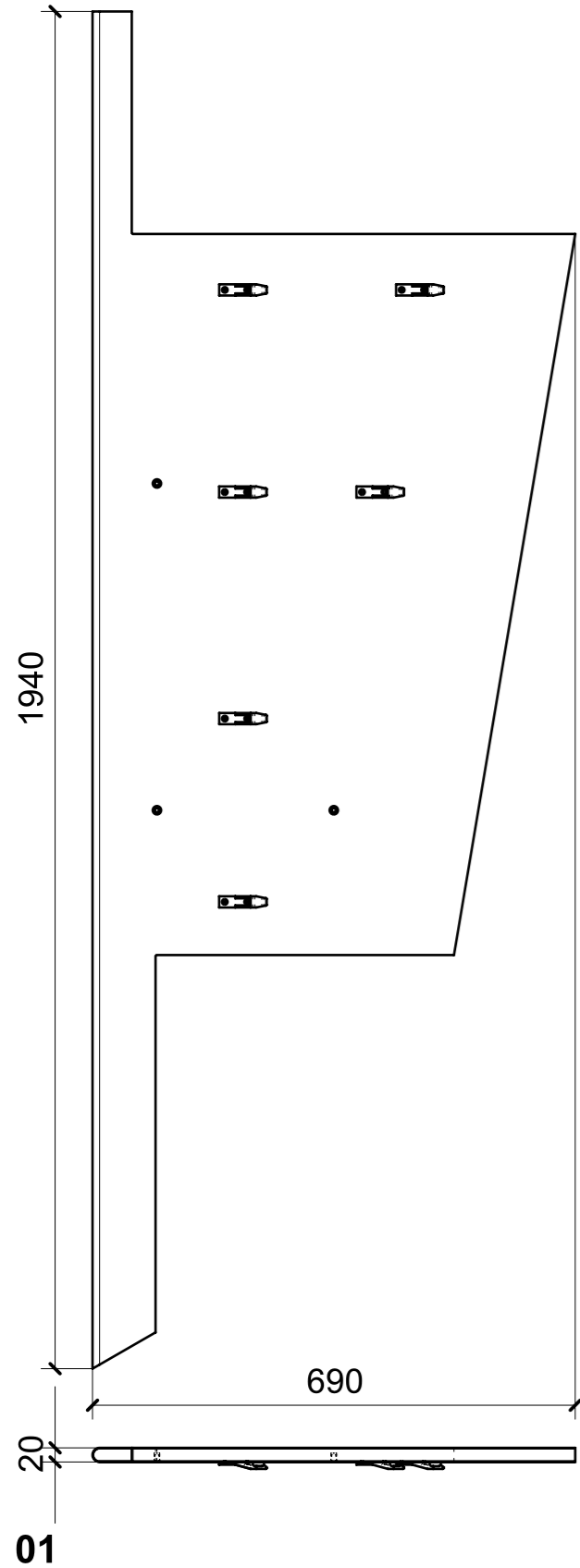

FERRAMENTA	QTY
BUSSOLA 6MA X 10 FORO DIAM.8	3
PARTE PANNELLO CON INCASTRO_HAFELE_262_49_356 OPPOSTO	3
PARTE PANNELLO CON INCASTRO_HAFELE_262_49_356 AGG. RIBALTATO	3
MS INCASSO_ITALVIPLA_972_FMPC_M1B	4

VERNICIATURA LASTRA/LACCATI:

● = VERNICIARE 1 LATO + FILI RASATI O BORDATI

NESSUN SIMBOLO = VERNICIARE 2 LATI + FILI RASATI O BORDATI

LOCALE	CODICE	DESCRIZIONE COMPONENTE	FINITURA	Q.TA
CABINA ARMATORE	MD299_R01_AAD01	TOP MOBILE CONTENITORE MURATA SX OPT	LAISTRA SCURA	1

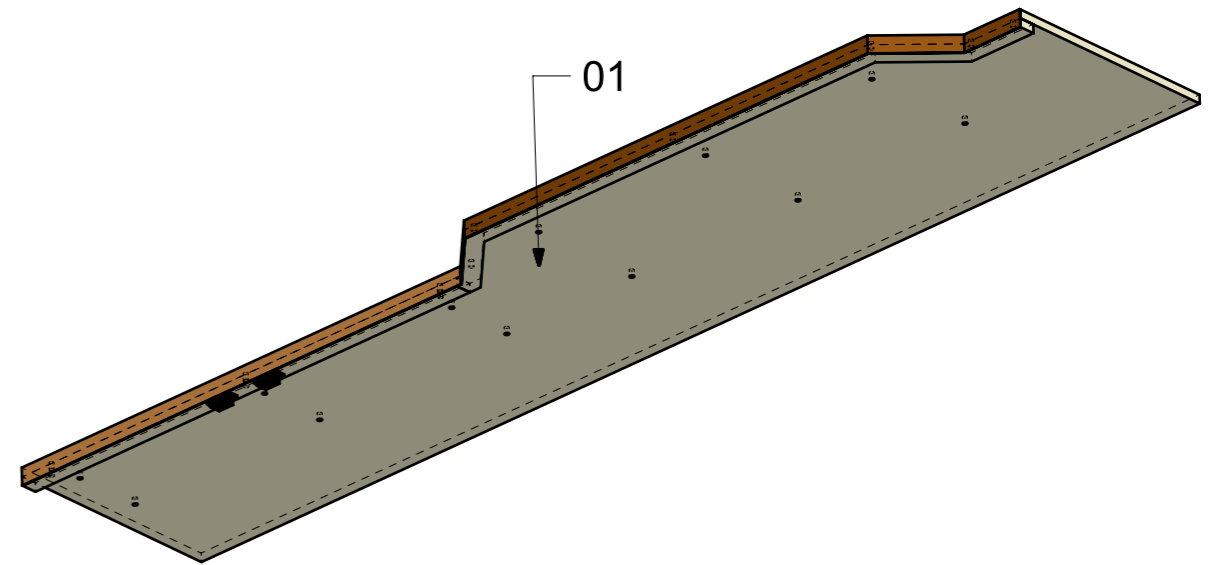
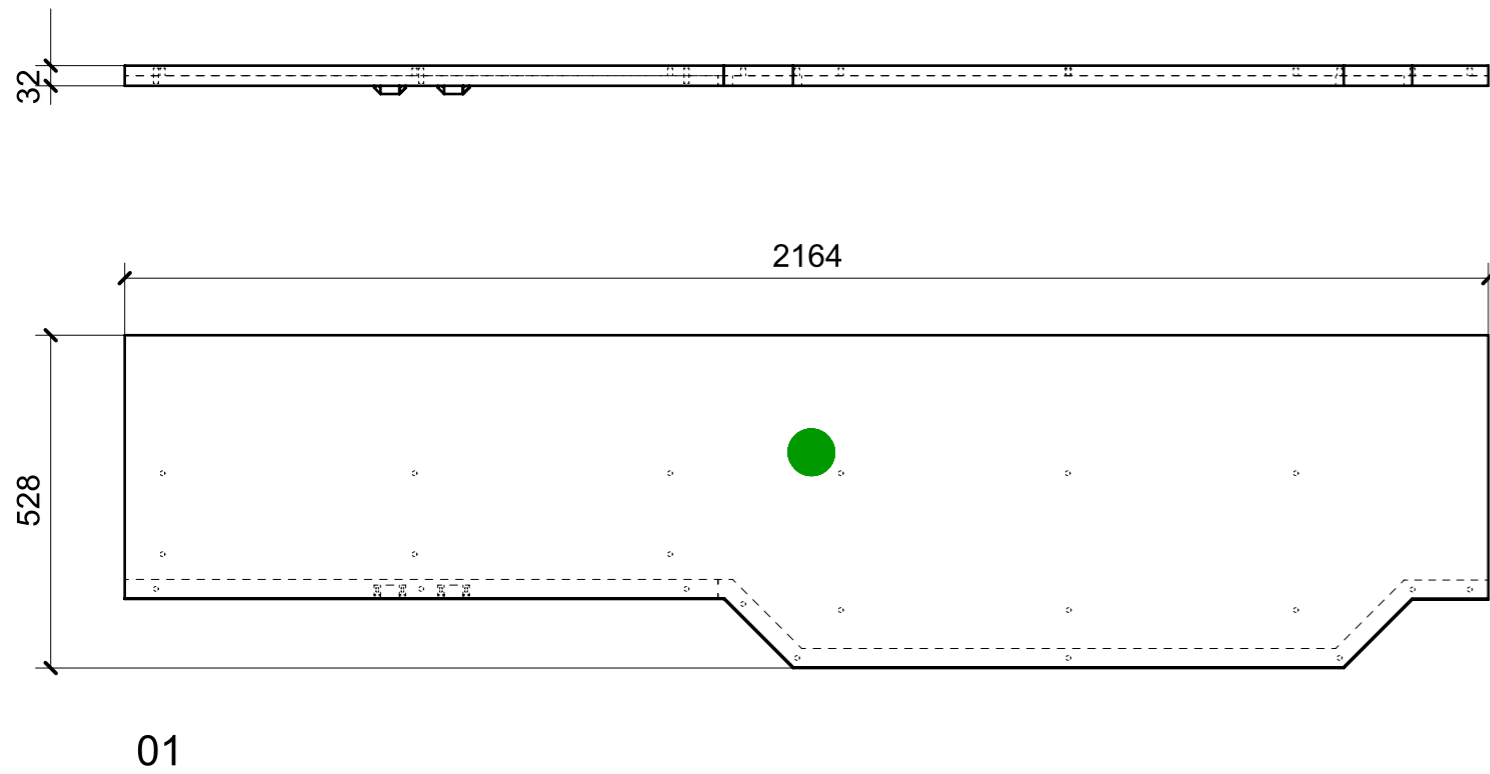

FERRAMENTA	QTY
CALAMITA SEALED MAGNETIC_TECNOPARTNER_MC-JM50-BL	2

VERNICIATURA LASTRA/LACCATI:

● = VERNICIARE 1 LATO + FILI RASATI O BORDATI

NESSUN SIMBOLO = VERNICIARE 2 LATI + FILI RASATI O BORDATI

LOCALE	CODICE	DESCRIZIONE COMPONENTE	FINITURA	Q.TA
CABINA ARMATORE	MD299_R01_AD01	MOBILE CONTENITORE MURATA SX	LASTRA SCURA	1

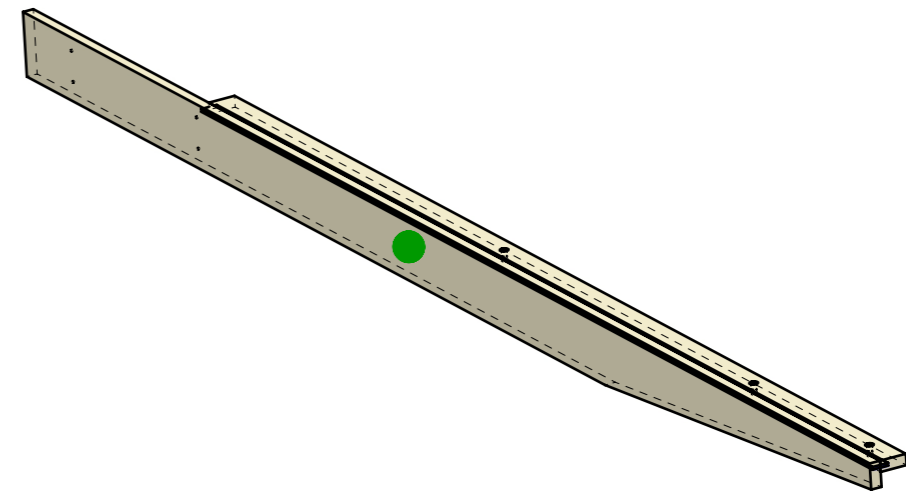
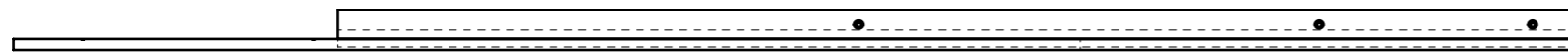
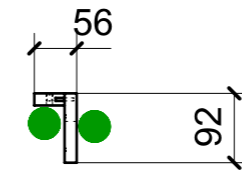
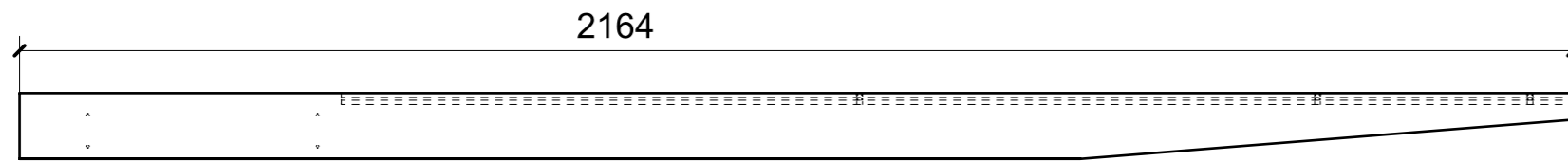

FERRAMENTA	QTY
BUSSOLA 6MA X 10 FORO DIAM.8	3

VERNICIATURA LASTRA/LACCATI:

● = VERNICIARE 1 LATO + FILI RASATI O BORDATI

NESSUN SIMBOLO = VERNICIARE 2 LATI + FILI RASATI O BORDATI

LOCALE	CODICE	DESCRIZIONE COMPONENTE	FINITURA	Q.TA
CABINA ARMATORE	MD299_R01_AE01	RIVESTIMENTO PARETE TV	LASTRA SCURA	1

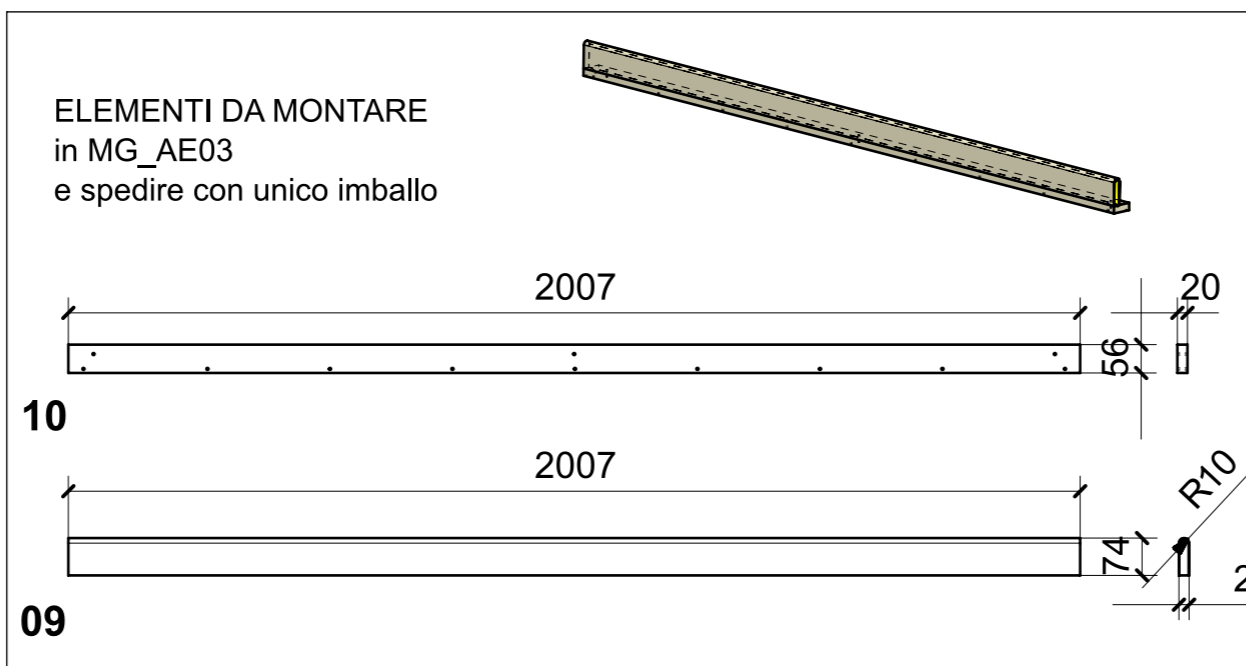
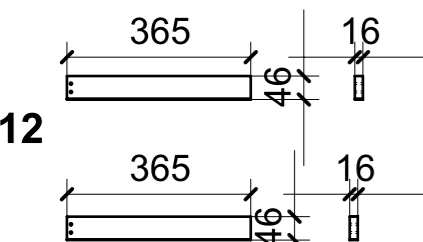
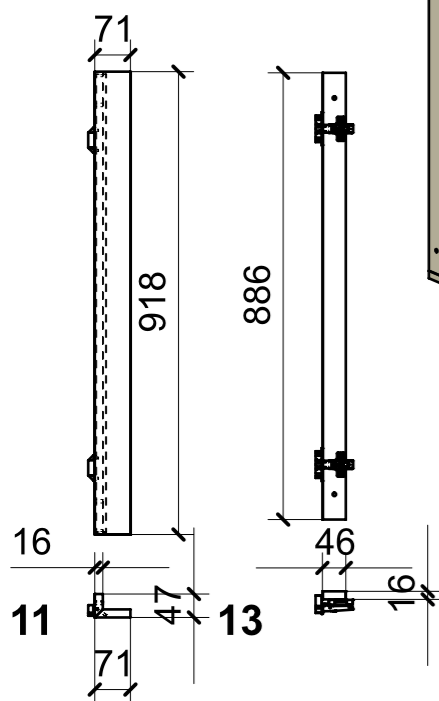
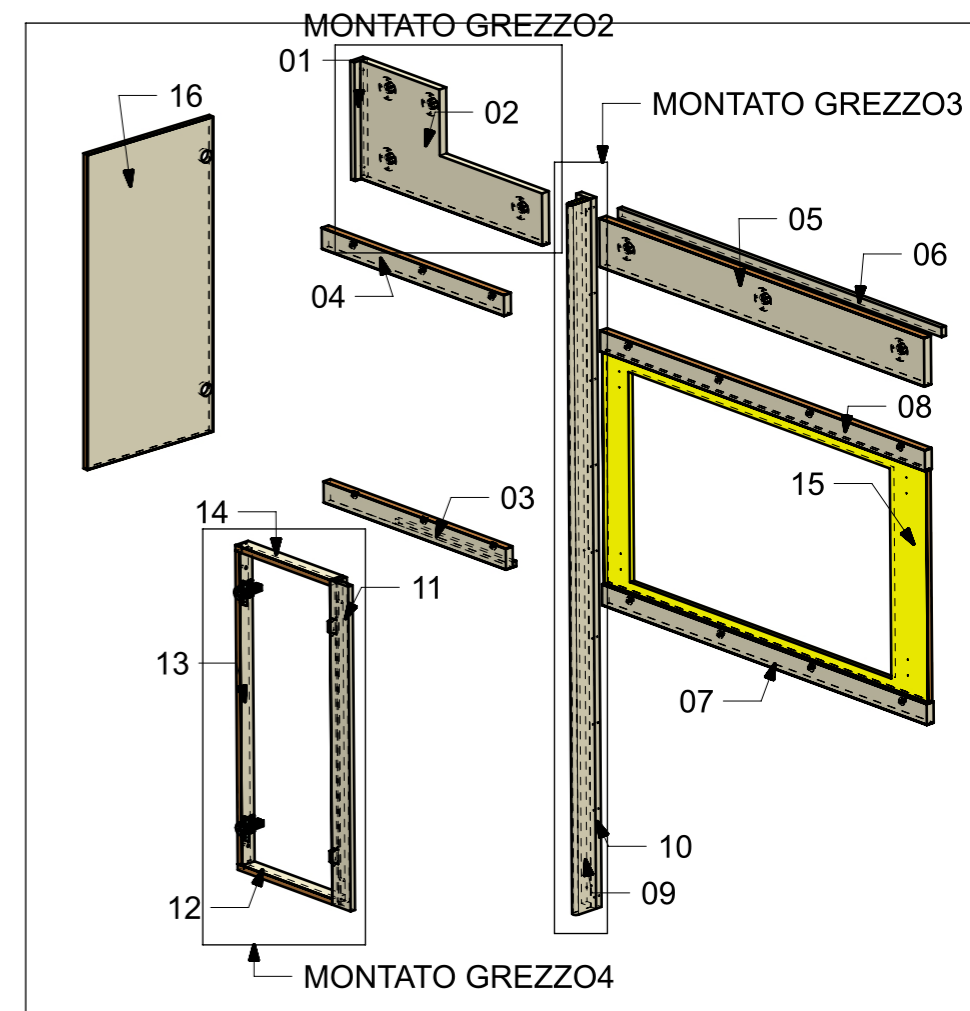
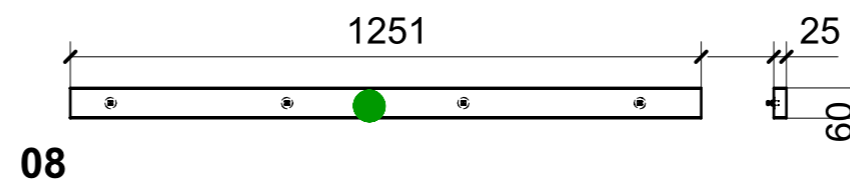
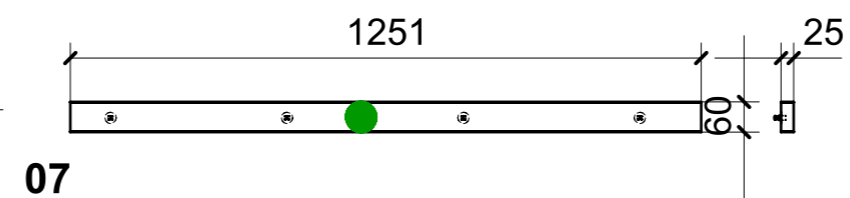
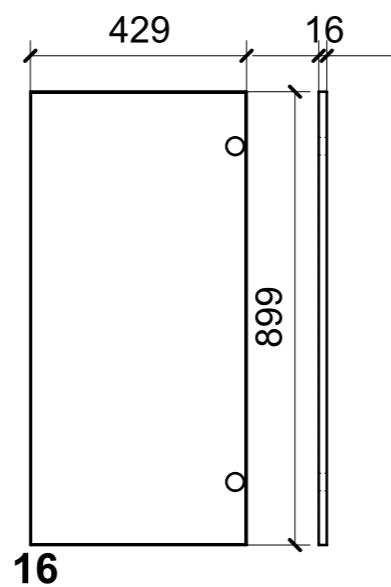
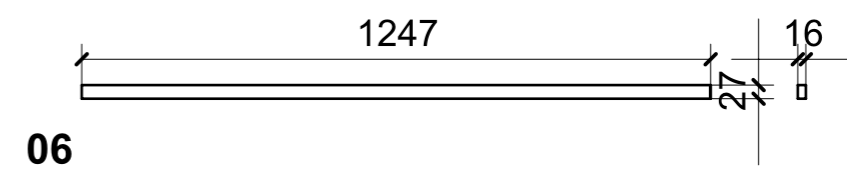
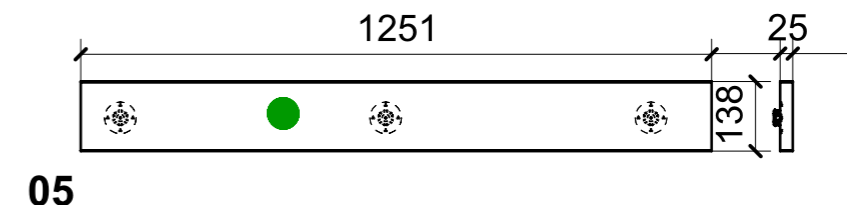
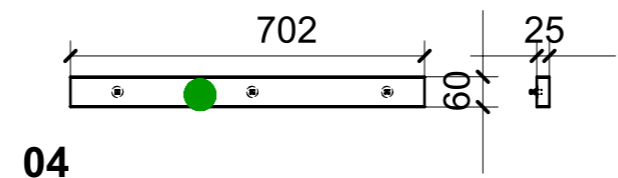
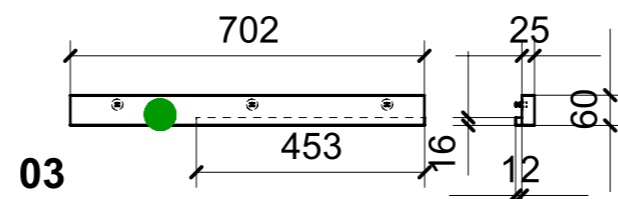
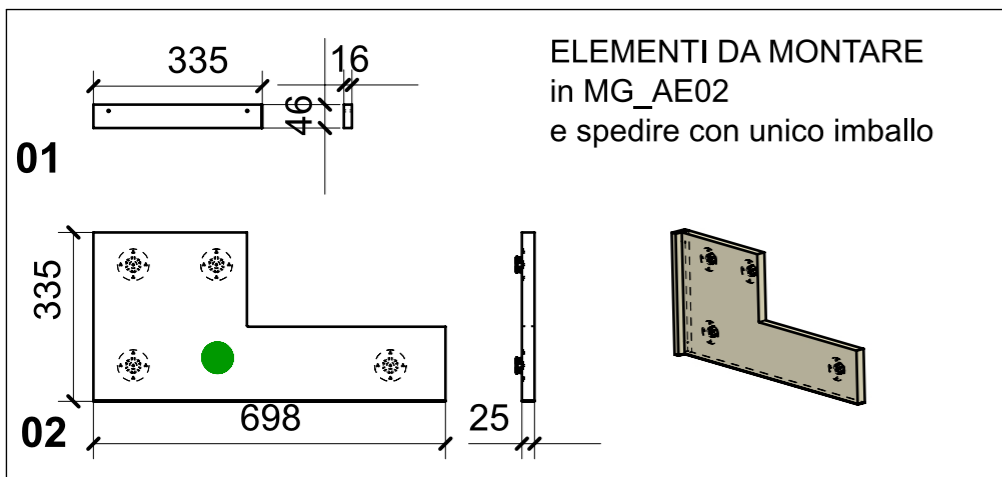

FERRAMENTA	QTY
BASE_6_HAFELE_329_84_026	2
BUSSOLA 5MA ANKOR BORGHI X CERNIERA PIANA	4
CALAMITA SEALED MAGNETIC_TECNOPARTNER_MC-JM50-BL	2
CERNIERA 94° PIANA AMMORTIZZATA_HAFELE_329_49_310	2
FITLOCK M_MASCHERPA_3MM_6020202101	7
MS INCASSO_ITALVIPLA_972_FMPC_M1B	14
VITE 4MAX8 ANKOR BORGHI X CERNIERA PIANA	4

VERNICIATURA LASTRA/LACCATI:

● = VERNICIARE 1 LATO + FILI RASATI O BORDATI

NESSUN SIMBOLO = VERNICIARE 2 LATI + FILI RASATI O BORDATI

LOCALE	CODICE	DESCRIZIONE COMPONENTE	FINITURA	Q.TA
CABINA ARMATORE	MD299_R01_AF01	STRUTTURA RIV. BAGNO OSPITI DX	LASTRA SCURA	1

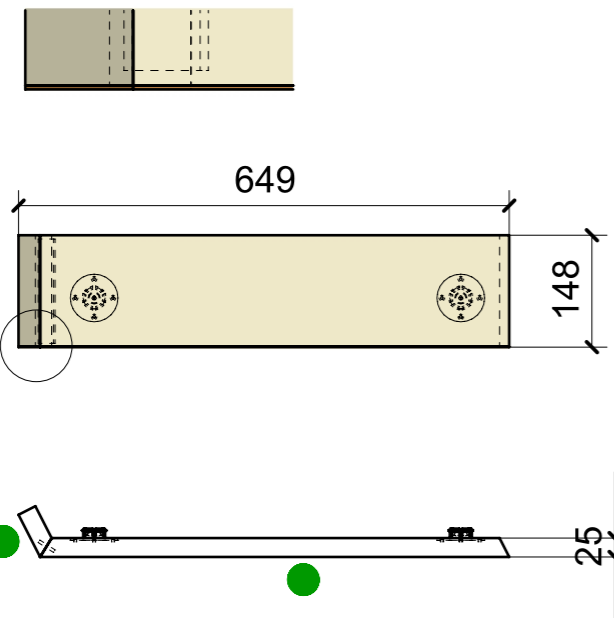

01

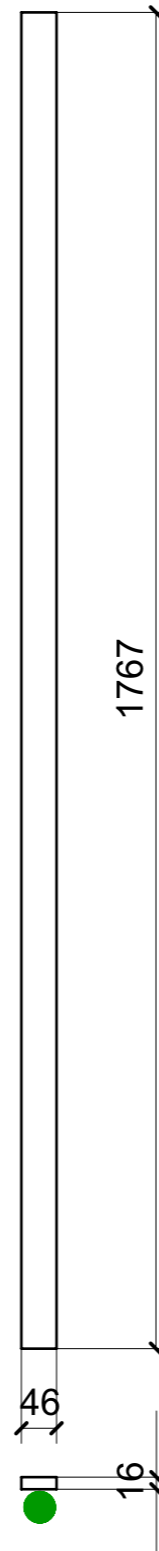

02

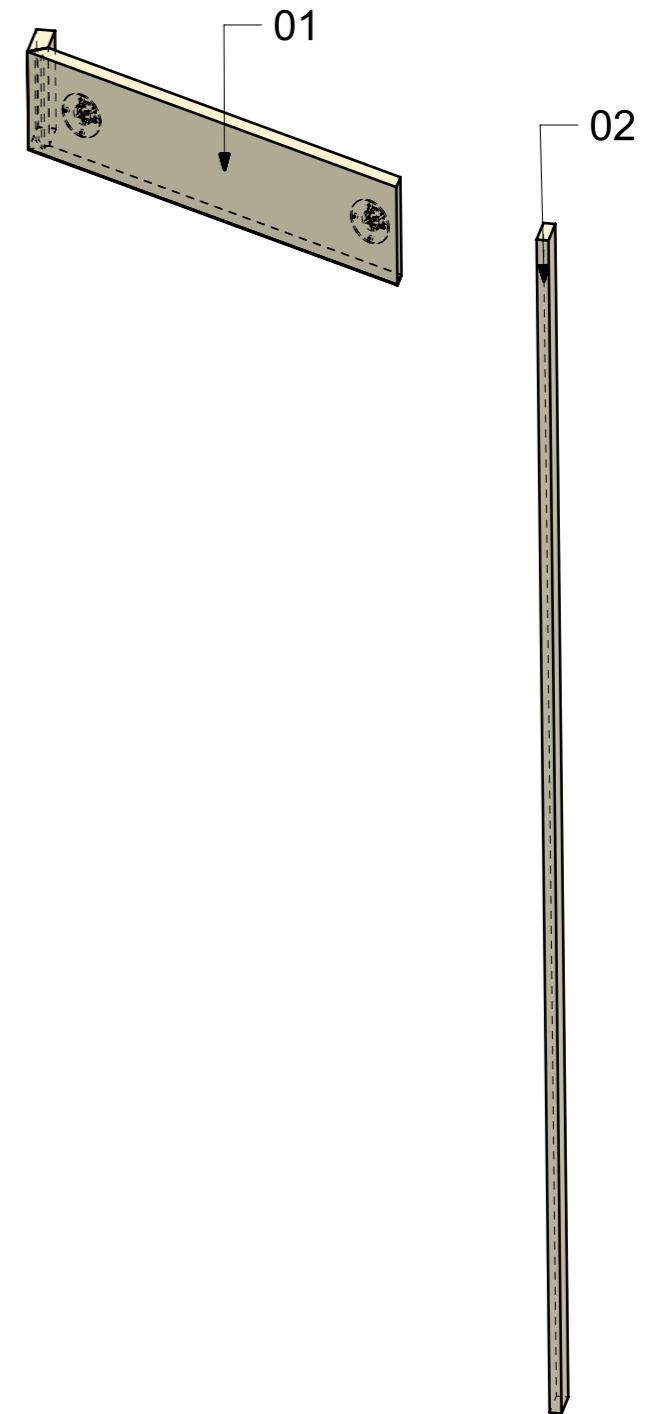

FERRAMENTA	QTY
VITE 6MA X 25 TESTA SVASATA	3
BUSSOLA 6MA X 10 FORO DIAM.8	2
FITLOCK F_MASCHERPA_6020101102	32
FITLOCK M_MASCHERPA_3MM_6020202101	15

VERNICIATURA LASTRA/LAGGATI:

● = VERNICIARE 1 LATO + FILI RASATI O BORDATI

NESSUN SIMBOLO = VERNICIARE 2 LATI + FILI RASATI O BORDATI

LOCALE	CODICE	DESCRIZIONE COMPONENTE	FINITURA	Q.TA
CABINA ARMATORE	MD299_R01_AG01	STRUTTURA RIV.BAGNO ARMATORE	LASTRA SCURA	1

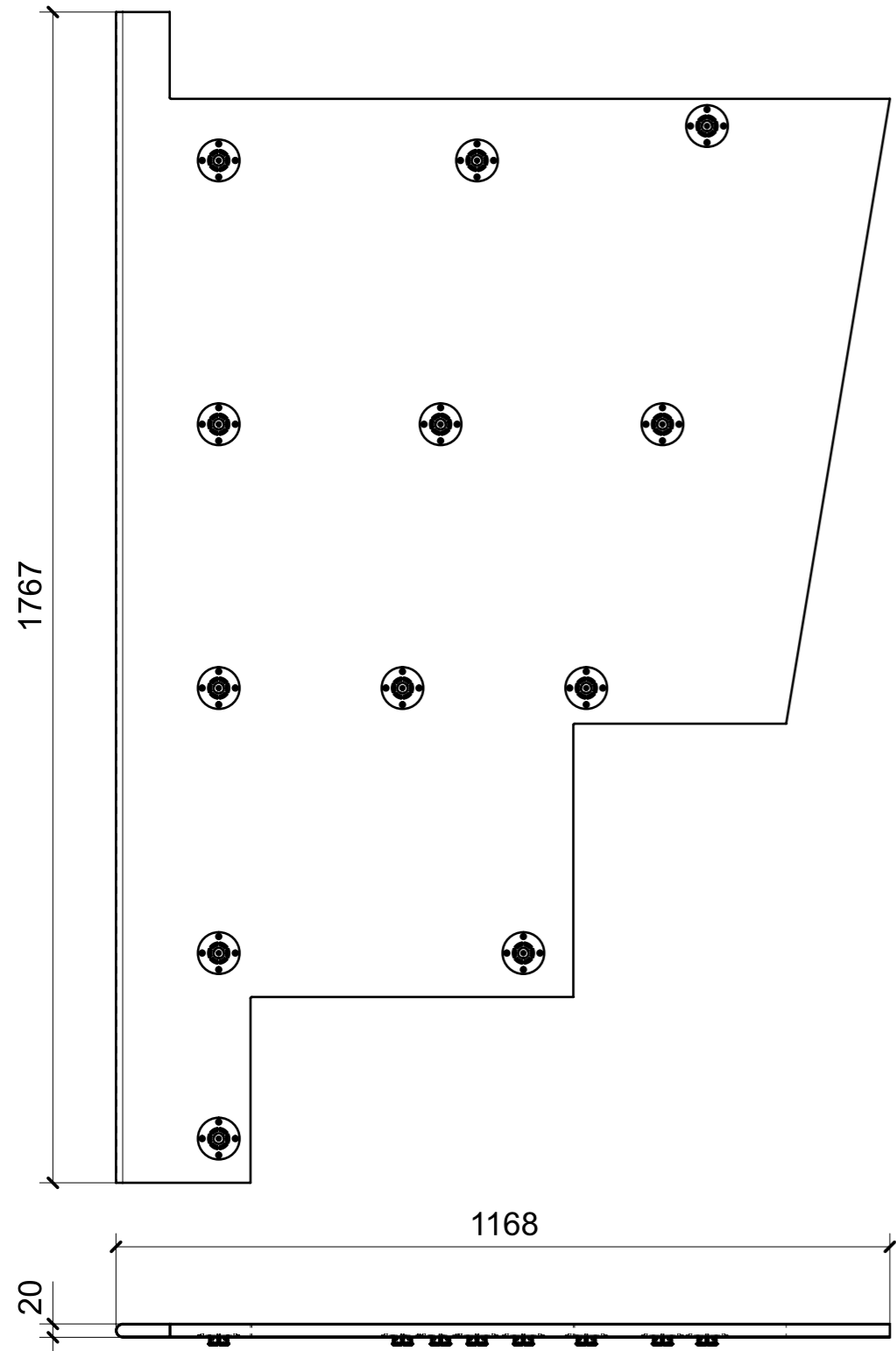

01



02

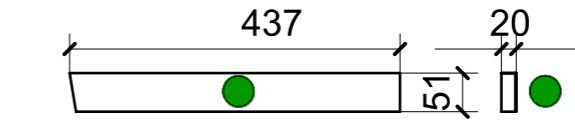

03

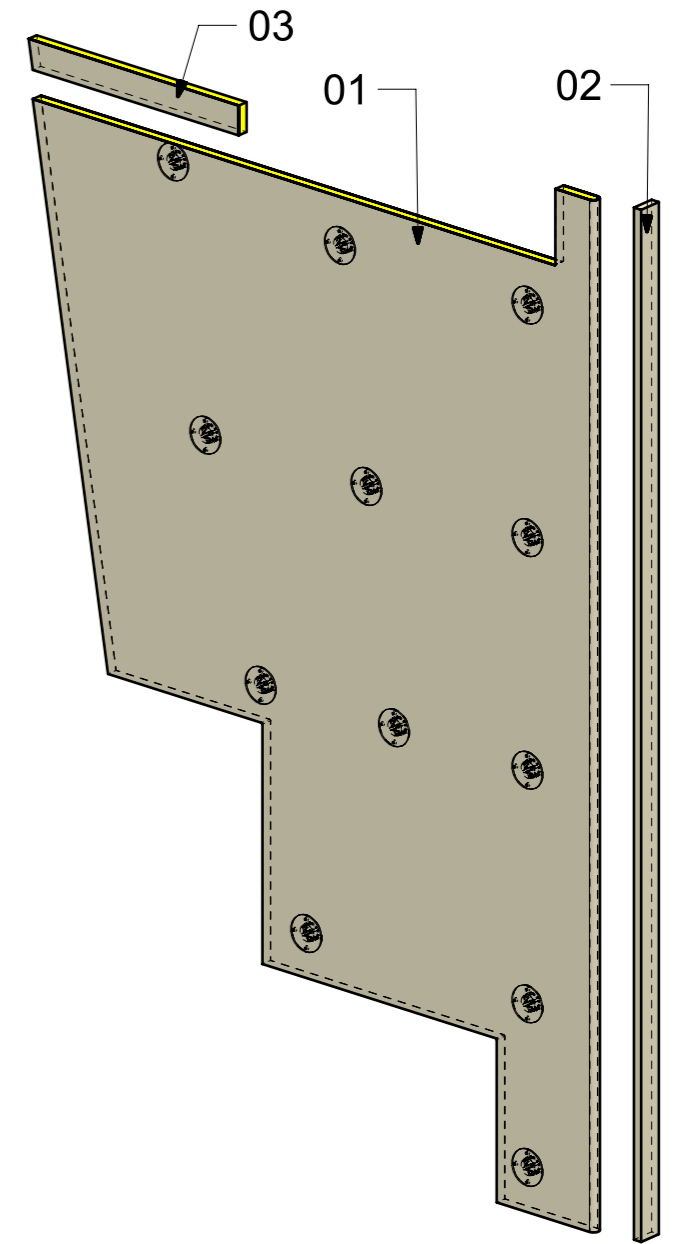

FERRAMENTA	QTY
FITLOCK M_MASCHERPA_3MM_6020202101	12

VERNICIATURA LASTRA/LACCATI:

● = VERNICIARE 1 LATO + FILI RASATI O BORDATI

NESSUN SIMBOLO = VERNICIARE 2 LATI + FILI RASATI O BORDATI

LOCALE	CODICE	DESCRIZIONE COMPONENTE	FINITURA	GR.
CABINA ARMATORE	MD299_R01_AH01	STRUTTURA MURATA BASSA DX	LASTRA SCURA	16

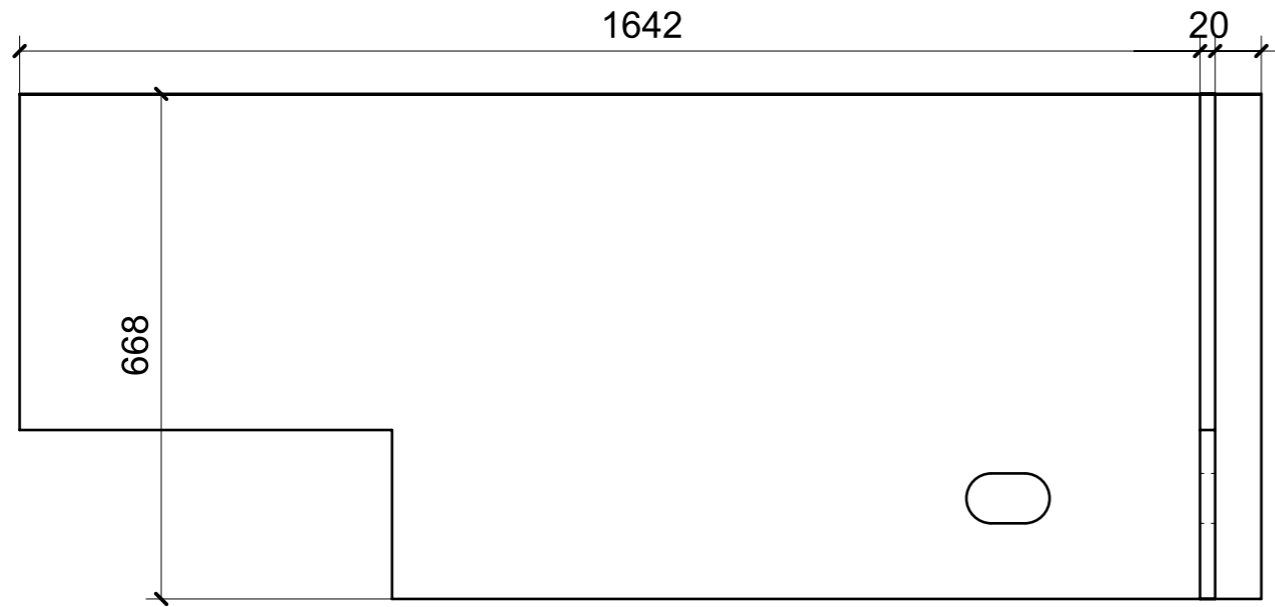

01

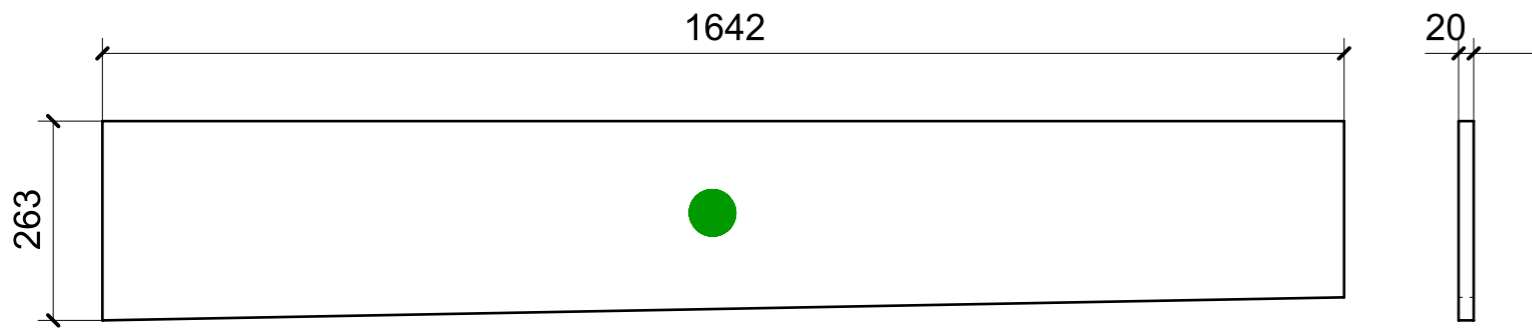
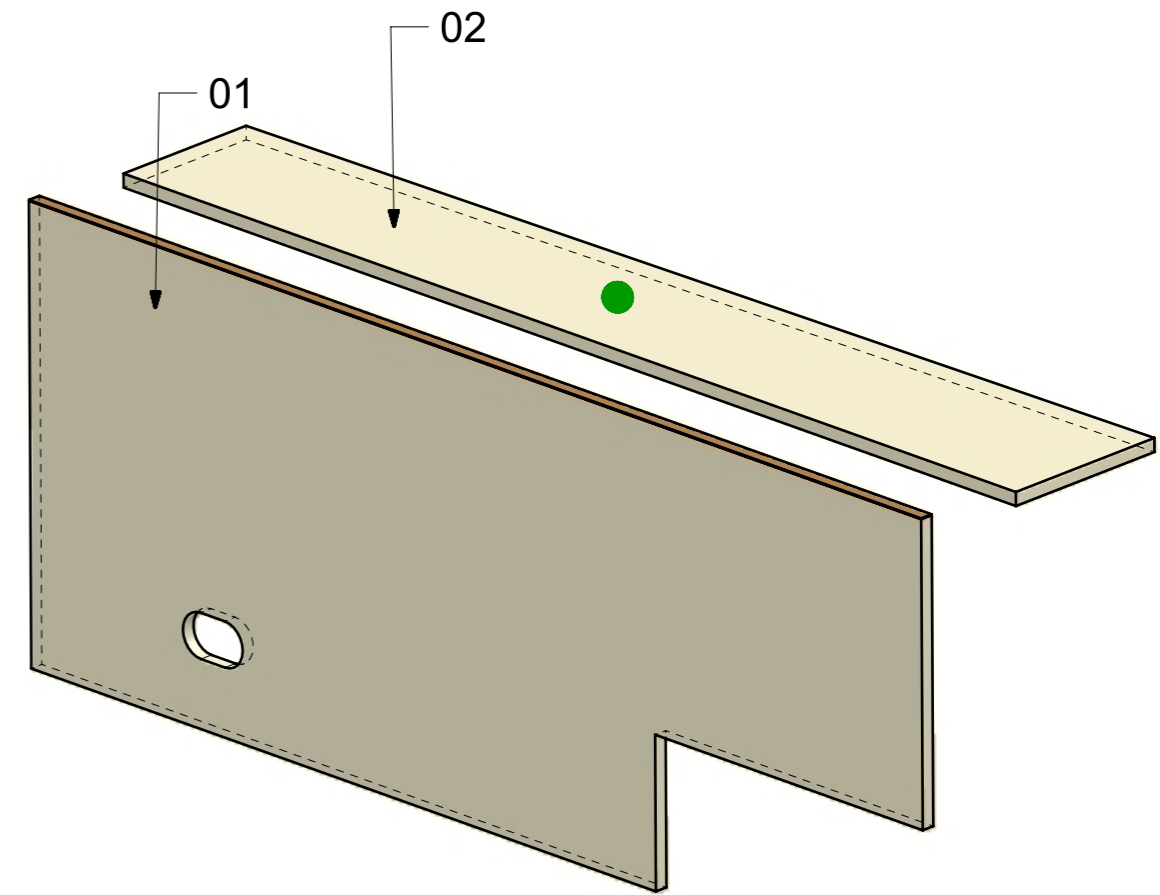

02

VERNICIATURA LASTRA/LACCATI:

● = VERNICIARE 1 LATO + FILI RASATI O BORDATI

NESSUN SIMBOLO = VERNICIARE 2 LATI + FILI RASATI O BORDATI

LOCALE	CODICE	DESCRIZIONE COMPONENTE	FINITURA	GR.
CABINA ARMATORE	MD299_R01_AK01	RIV. COLONNA SX VAR 2	LASTRA SCURA	9

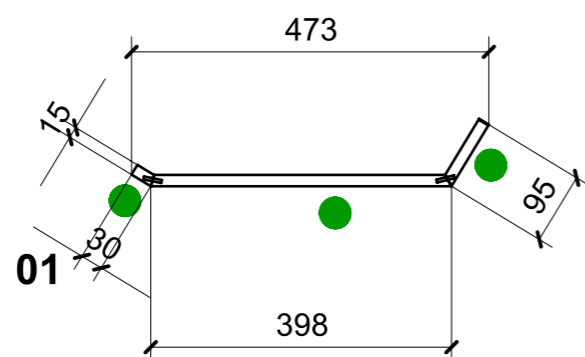
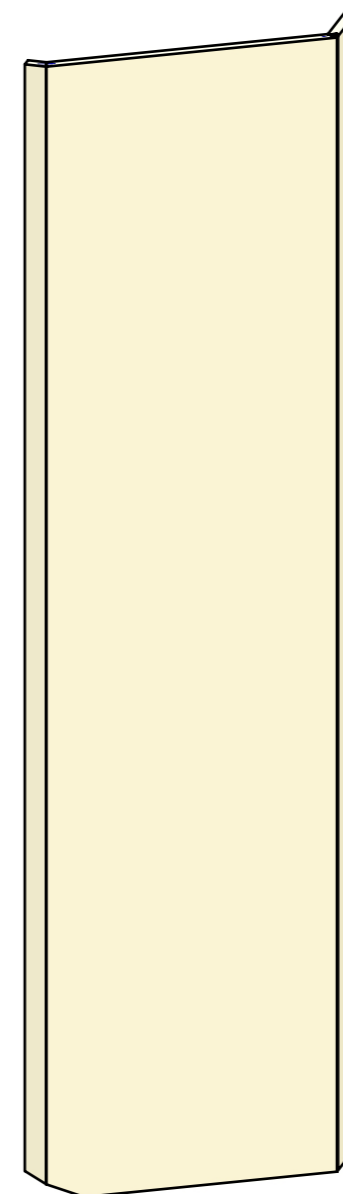
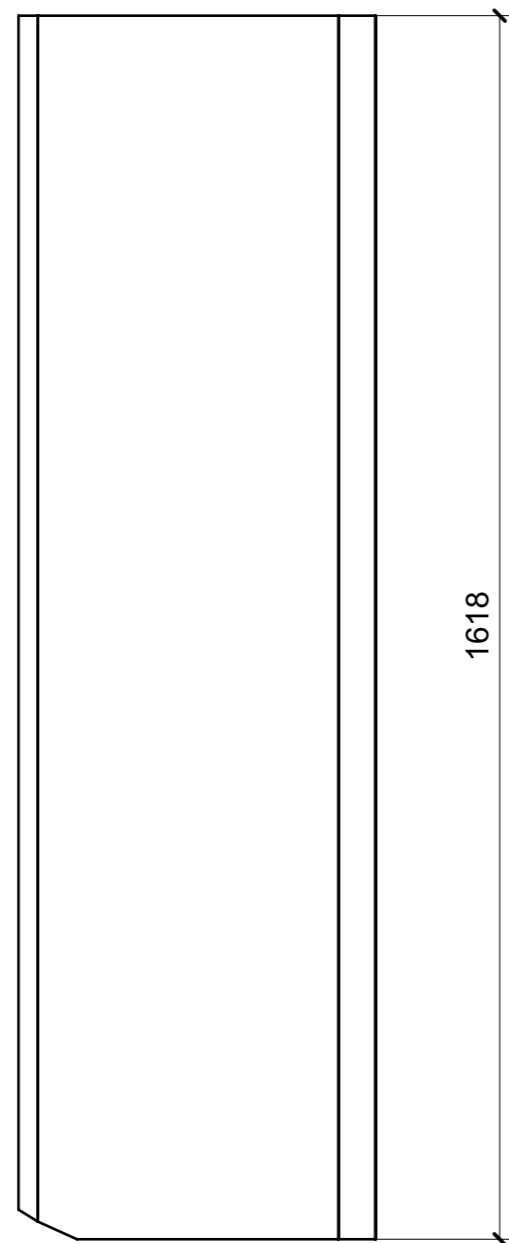

VERNICIATURA LASTRA/LACCATI:

● = VERNICIARE 1 LATO + FILI RASATI O BORDATI

NESSUN SIMBOLO = VERNICIARE 2 LATI + FILI RASATI O BORDATI

LOCALE	CODICE	DESCRIZIONE COMPONENTE	FINITURA	Q.TA
CABINA ARMATORE	MD299_R01_AL01	TAVOLINO A RIBALTA MURATA DX_OPT	LASTRA SCURA	1

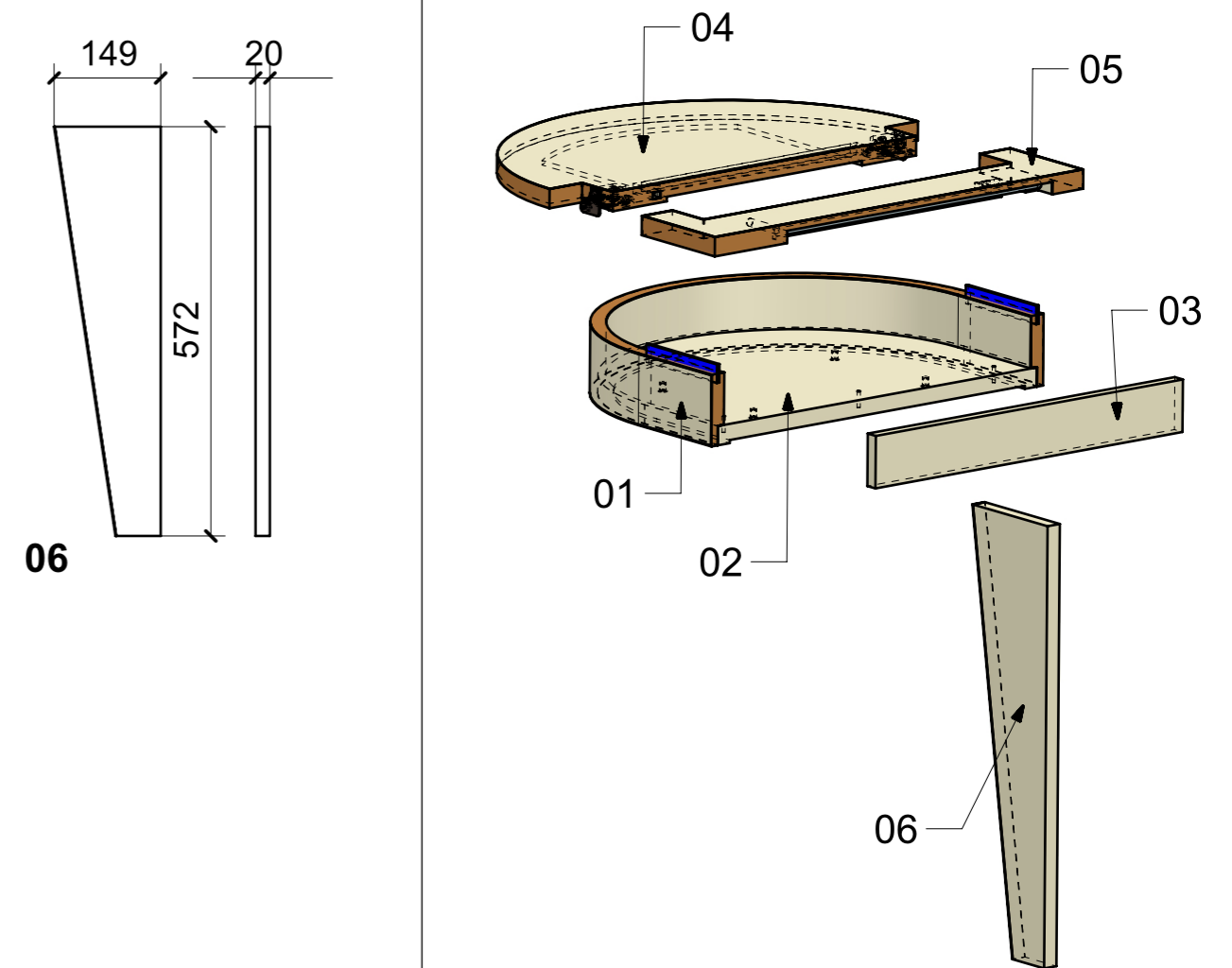
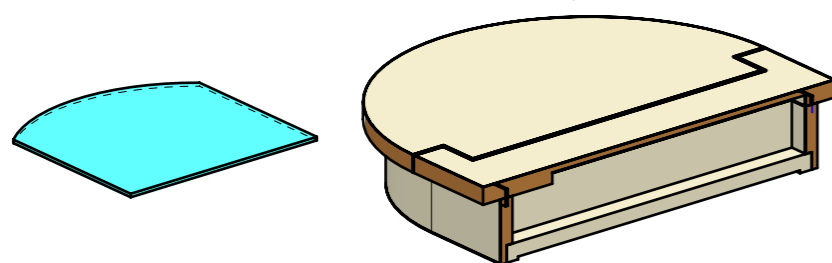
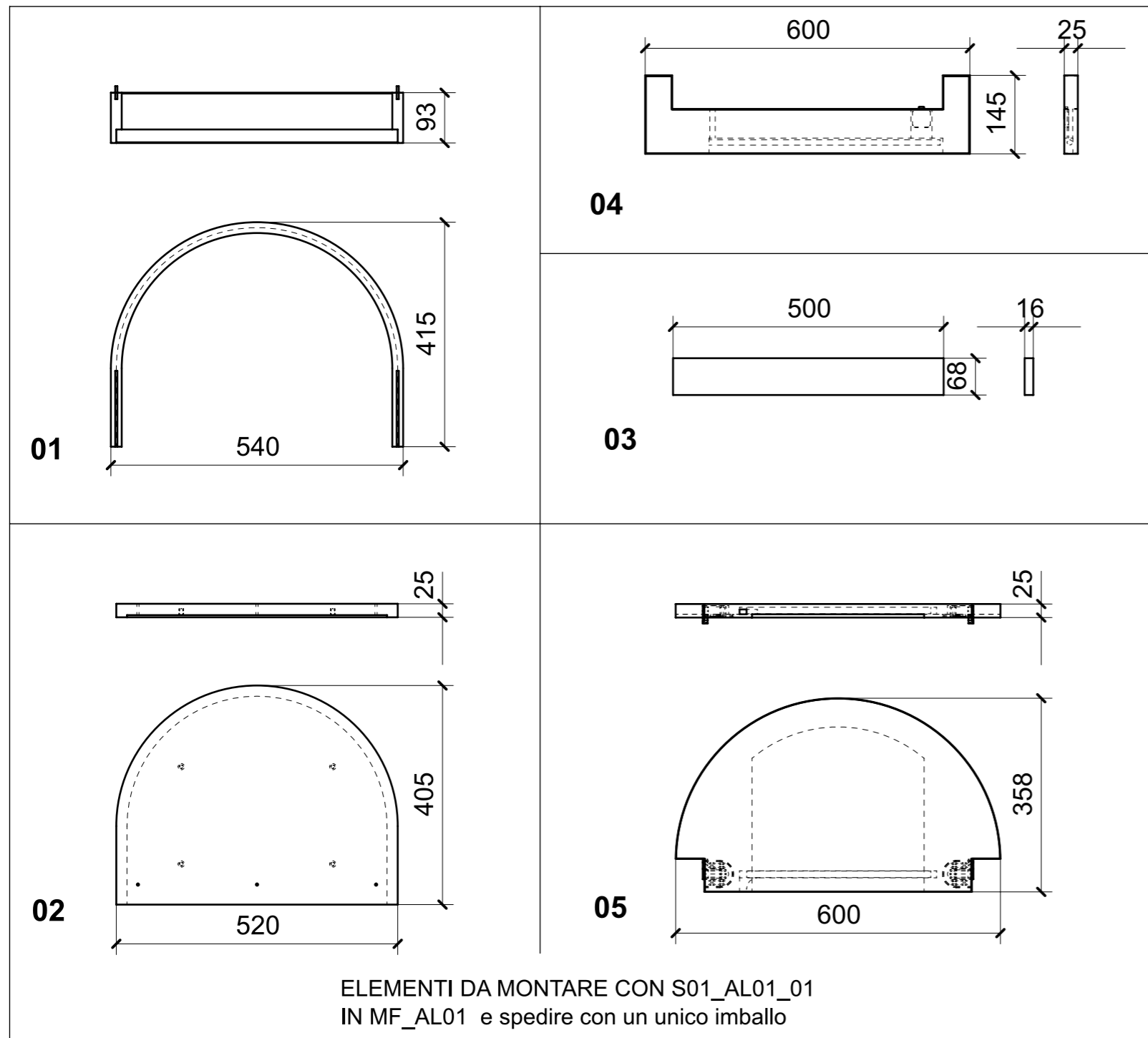

FERRAMENTA	QTY
BUSSOLA 6MA X 10 FORO DIAM.8	4
CP CERNIERE PER COPERCHIO SOFT-CLOSE_HAFELE_356_53_310	1
LAMPADA MICRO MECCANO 24V MM.340 OPAL-STR DA INCASSO SENZA INTERRUPTORE_ESSEPI_	1
MECCANO PROLUNGA CAVETTO 24V MT 2,2 ALIMENTAZIONE	1
INTERRUPTORE CIRCUITO_AMAZON	1

VERNICIATURA LASTRA/LACCATI:

● = VERNICIARE 1 LATO + FILI RASATI O BORDATI

NESSUN SIMBOLO = VERNICIARE 2 LATI + FILI RASATI O BORDATI

LOCALE	CODICE	DESCRIZIONE COMPONENTE	FINITURA	GR.
CABINA ARMATORE	MD299_R01_AO01	STRUTTURA TESTALETTO	LASTRA SCURA	16

01

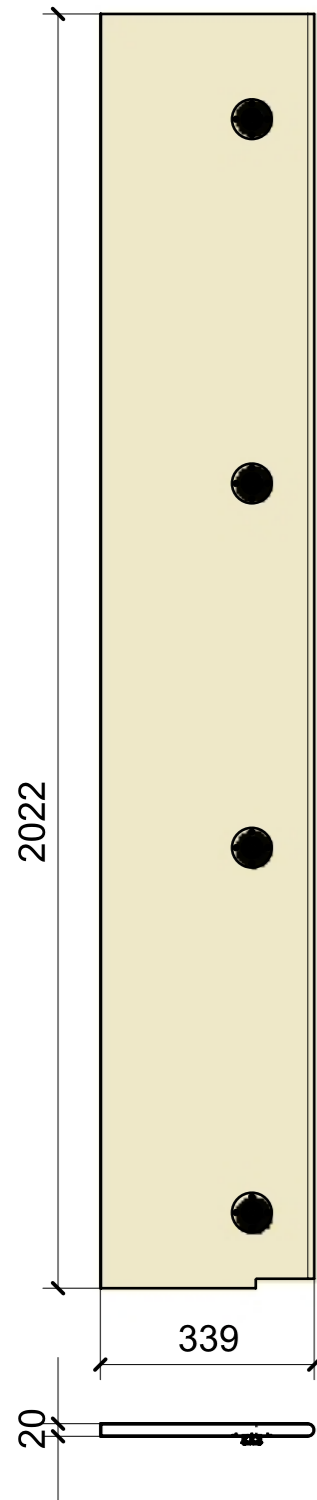

02

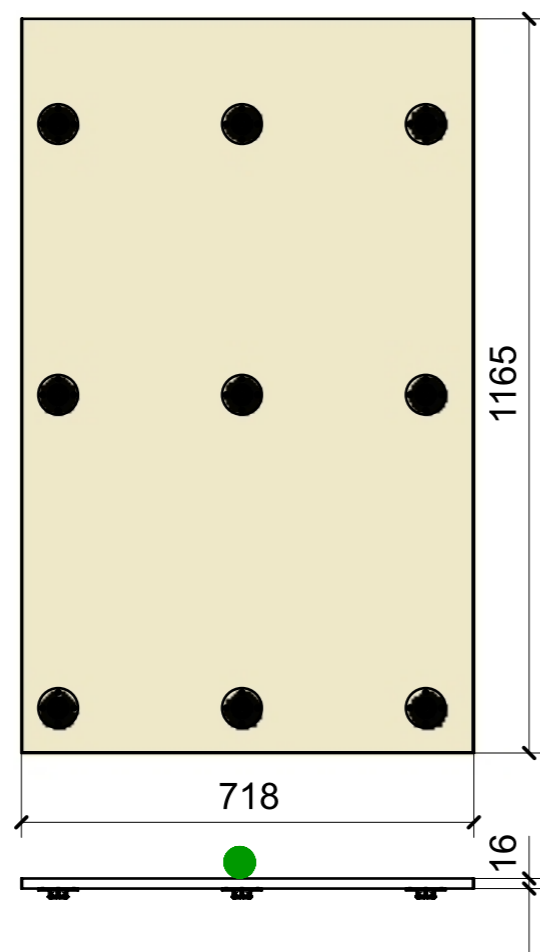

03

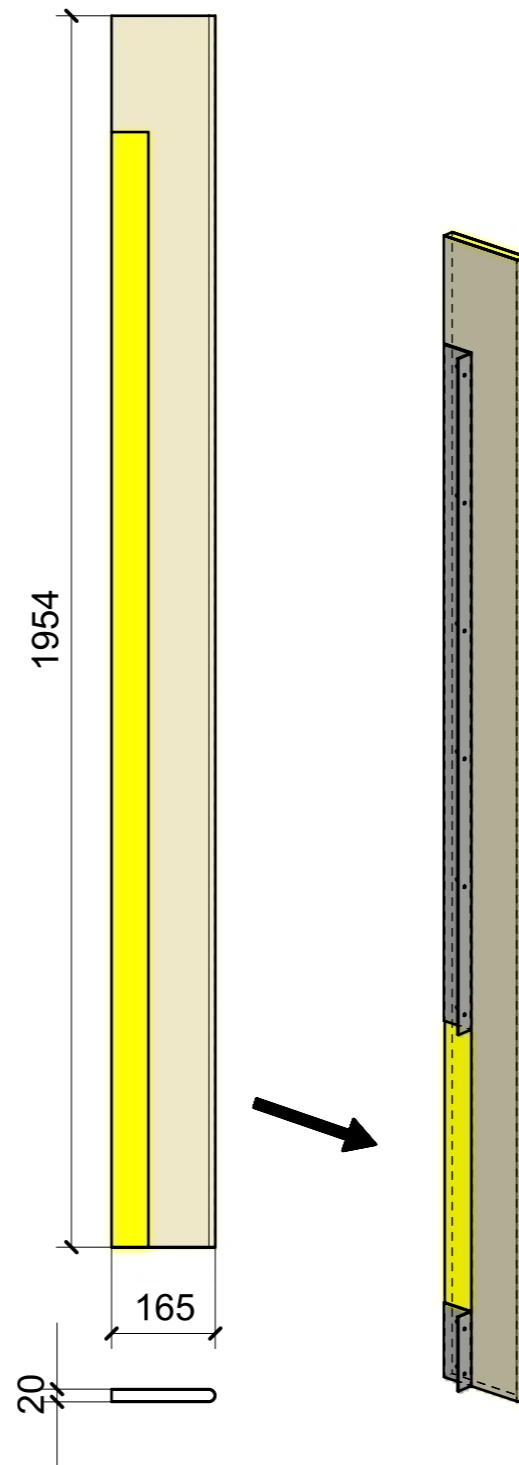

ELEMENTO DA MONTARE CON A07/A08 IN MF_AO01
e spedire con unico imballo

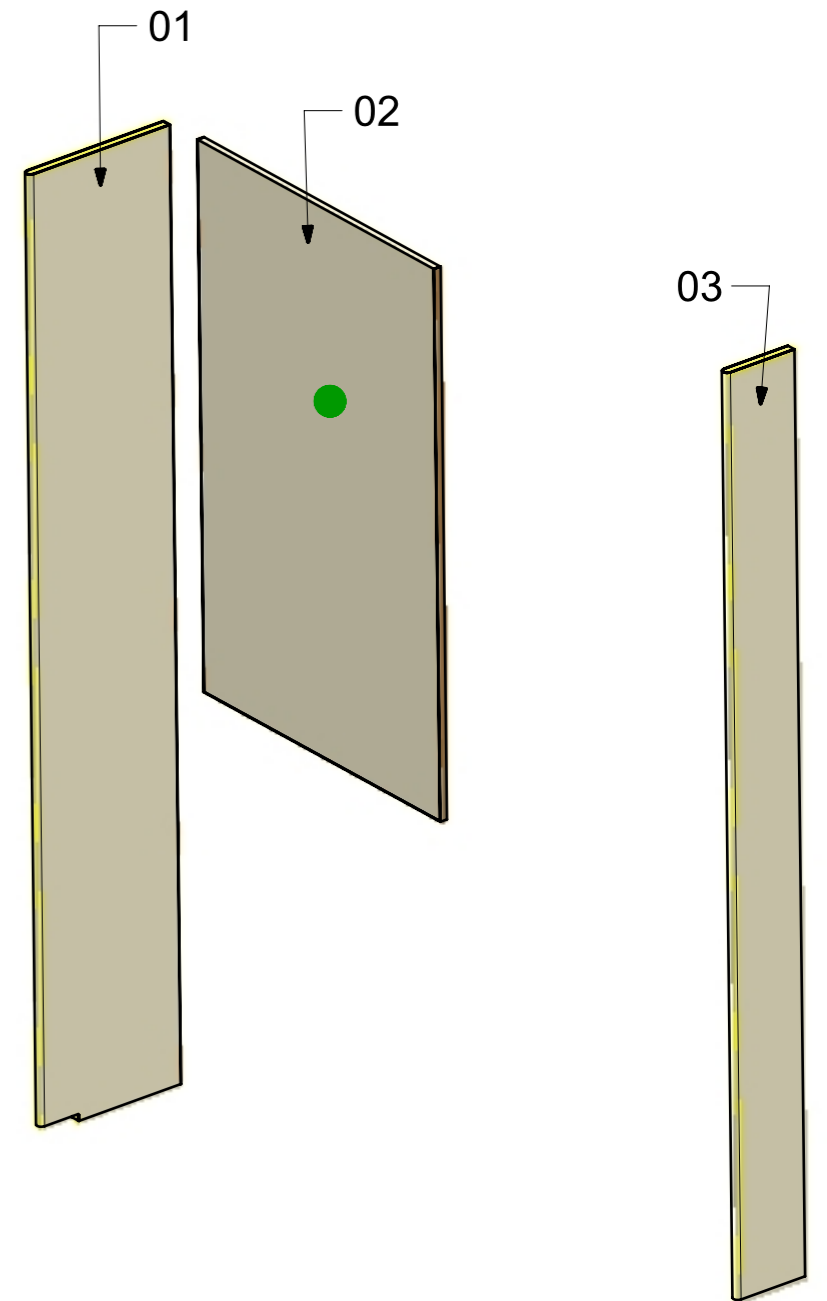

FERRAMENTA	QTY
FITLOCK M_MASCHERPA_3MM_6020202101	13

VERNICIATURA LASTRA/LACCATI:

● = VERNICIARE 1 LATO + FILI RASATI O BORDATI

NESSUN SIMBOLO = VERNICIARE 2 LATI + FILI RASATI O BORDATI

LOCALE	CODICE	DESCRIZIONE COMPONENTE	FINITURA	Q.TA
CABINA ARMATORE	MD299_R01_AP01	LETTO_STD VAR1	LASTRA SCURA	1

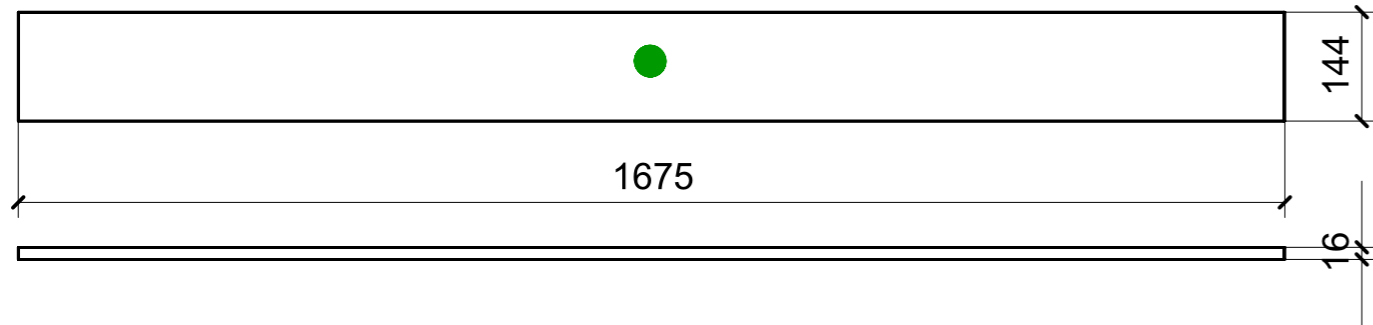

01

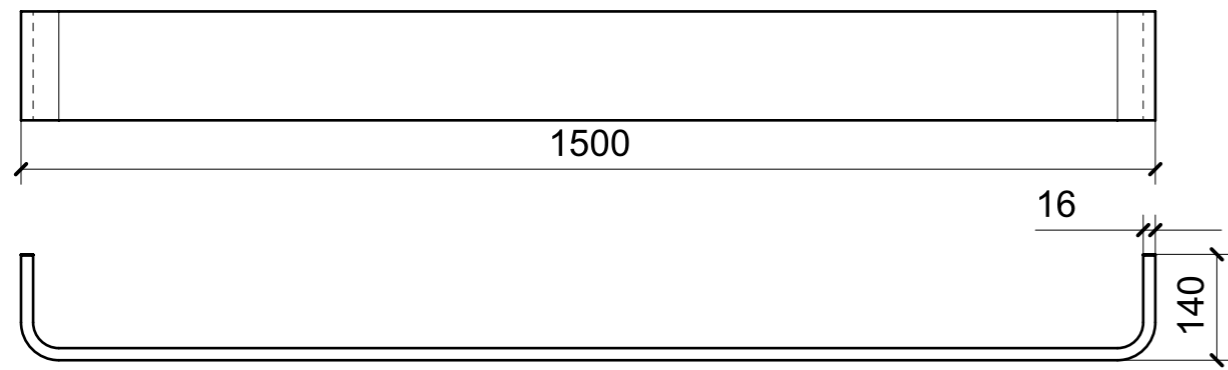

02

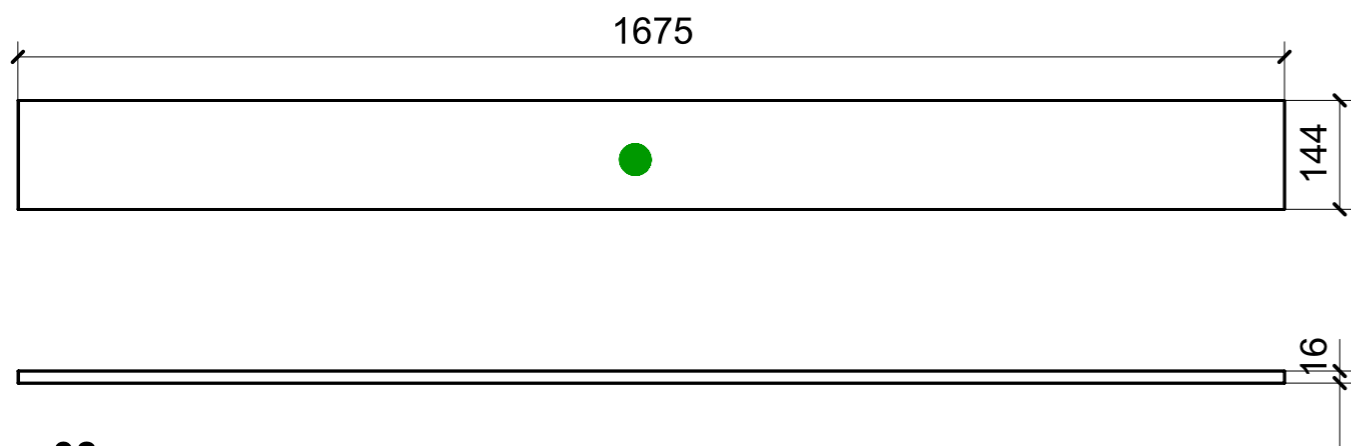

03

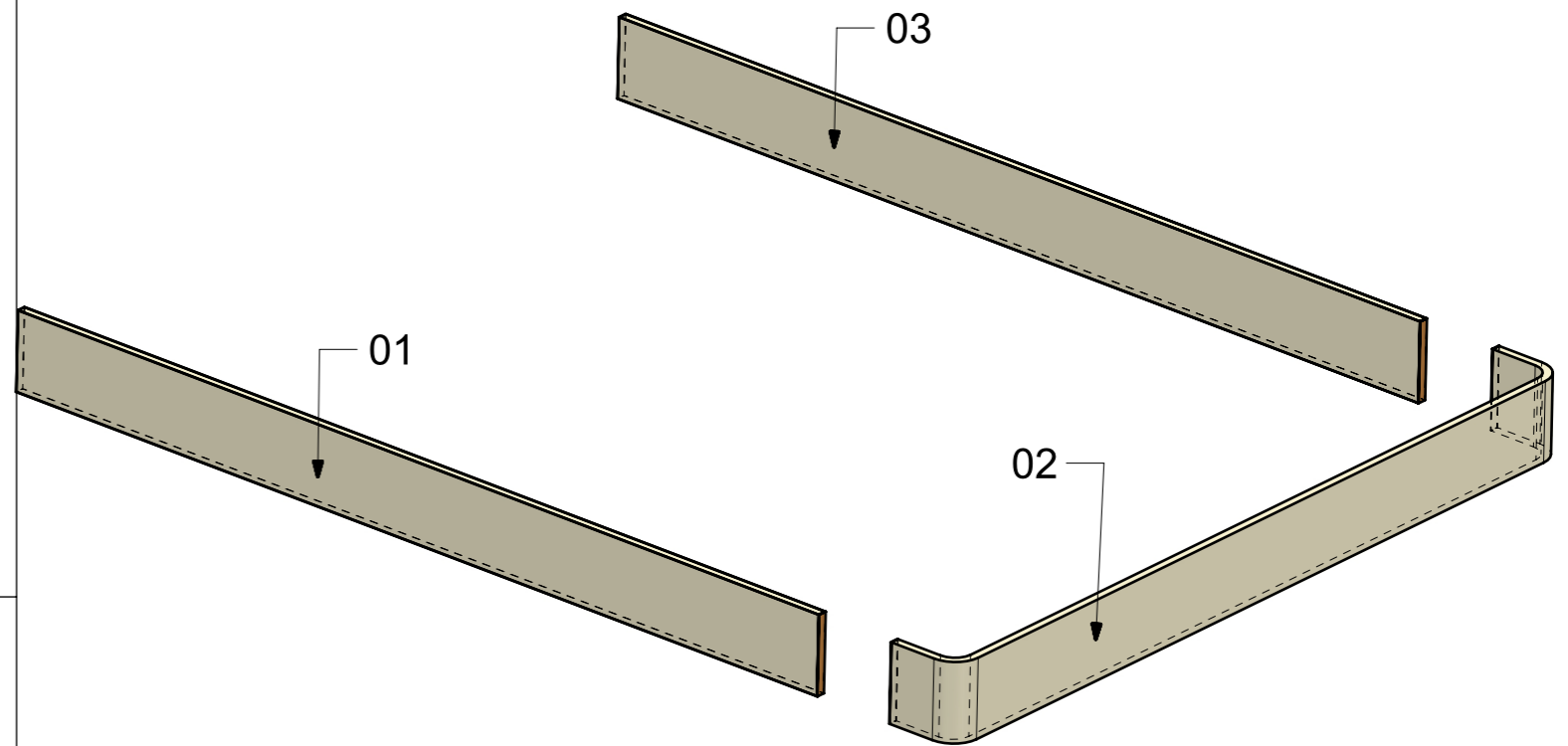

VERNICIATURA LASTRA/LACCATI:

● = VERNICIARE 1 LATO + FILI RASATI O BORDATI

NESSUN SIMBOLO = VERNICIARE 2 LATI + FILI RASATI O BORDATI

LOCALE	CODICE	DESCRIZIONE COMPONENTE	FINITURA	GR.
CABINA ARMATORE	MD299_R01_AQ01	COMODINO SX_STD VAR 1	LASTRA SCURA	16

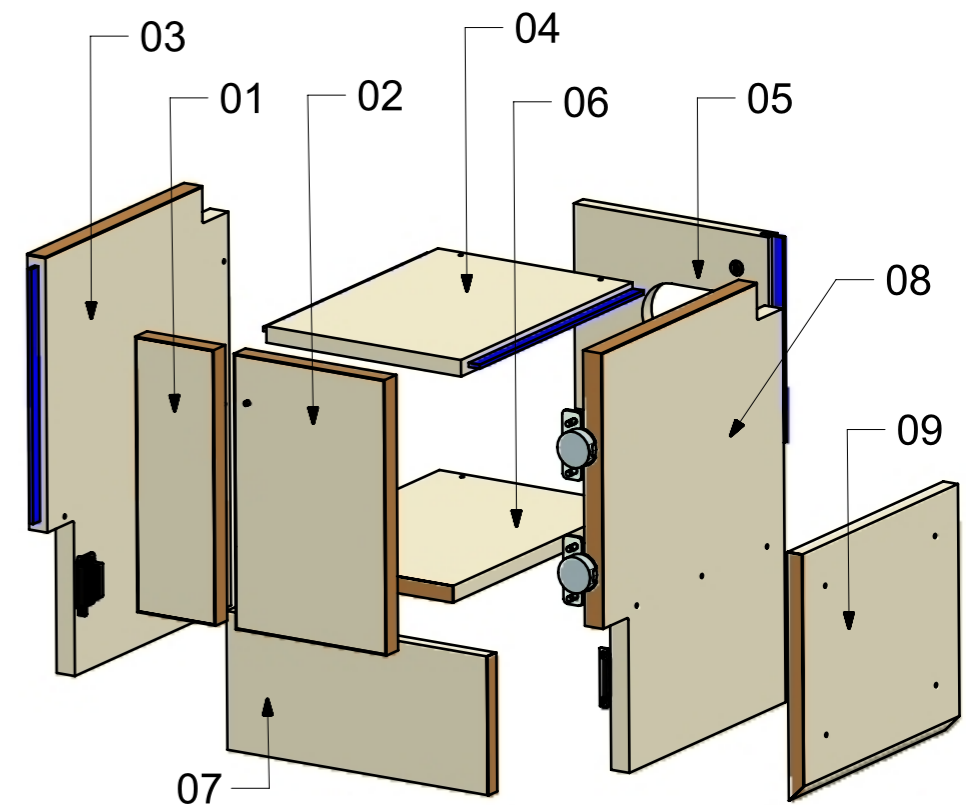
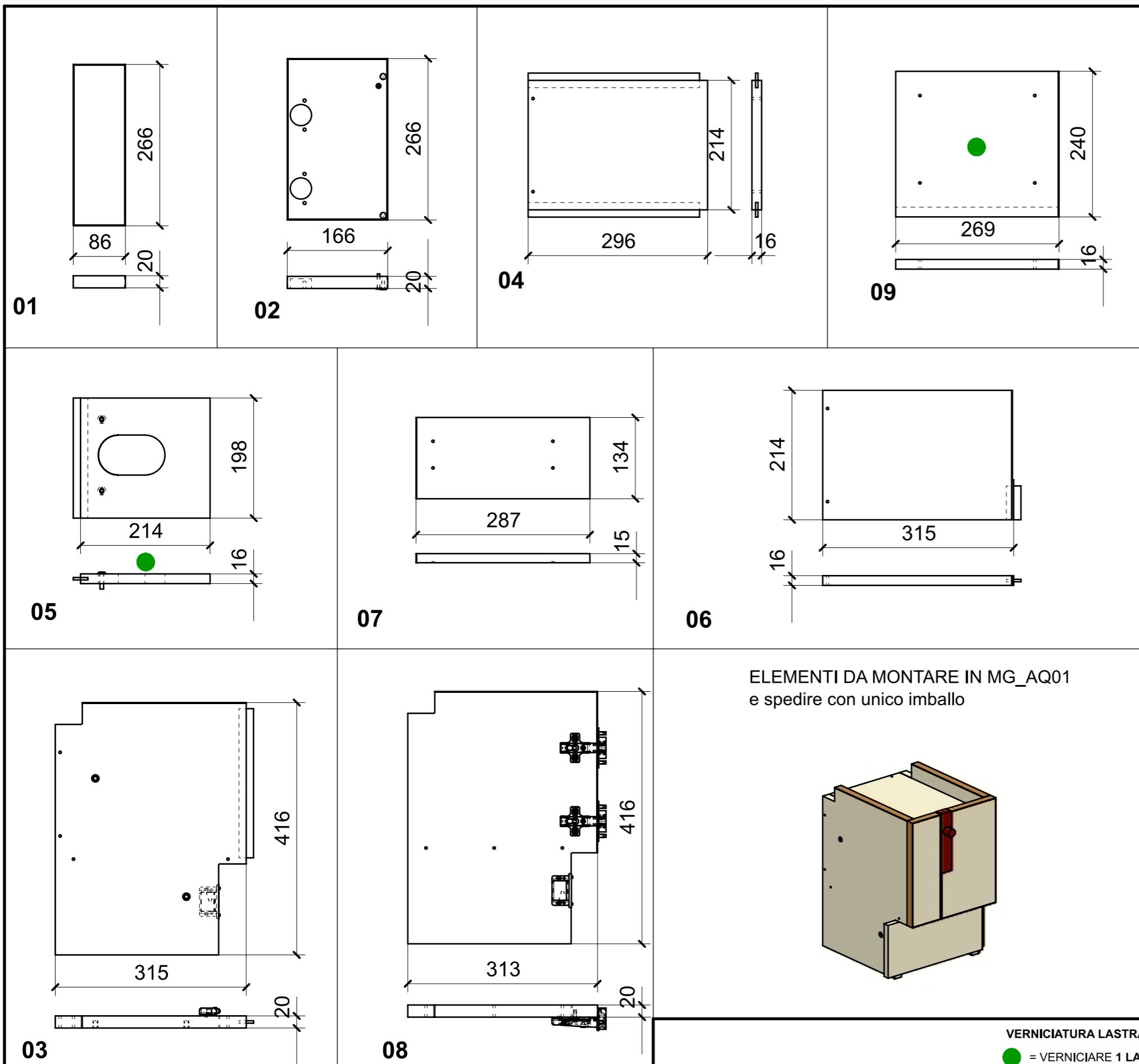

ELEMENTI DA MONTARE IN MG_AQ01
e spedire con unico imballo

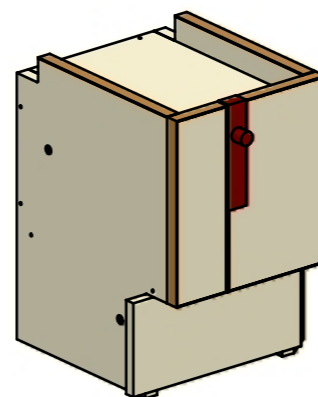

FERRAMENTA	QTY
BASE_0_HAFELE_329_84_020	2
BUSSOLA 5MA ANKOR BORGHI X BASE 0	4
BUSSOLA 5MA ANKOR BORGHI X CERNIERA PIANA	4
BUSSOLA 6MA X 10 FORO DIAM.8	2
CERNIERA 94° PIANA AMMORTIZZATA_HAFELE_329_49_310	2
CHIUSURA A SPINTA_TECHNOPARTNER_SOU C3-203	2
GOMMINO PARACOLPO ANTA	2
VITE 4MA X 25 TESTA SVASATA ESAGONALE NERA	1
VITE 4MAX8 ANKOR BORGHI X BASE 0	4
VITE 4MAX8 ANKOR BORGHI X CERNIERA PIANA	4
VITE 6MA X 25 TESTA BOMBATA	2

VERNICIATURA LASTRA/LACCATI:

● = VERNICIARE 1 LATO + FILI RASATI O BORDATI

NESSUN SIMBOLO = VERNICIARE 2 LATI + FILI RASATI O BORDATI

LOCALE	CODICE	DESCRIZIONE COMPONENTE	FINITURA	GR.
CABINA ARMATORE	MD299_R01_AR01	COMODINO DX_STD VAR 1	LASTRA SCURA	16

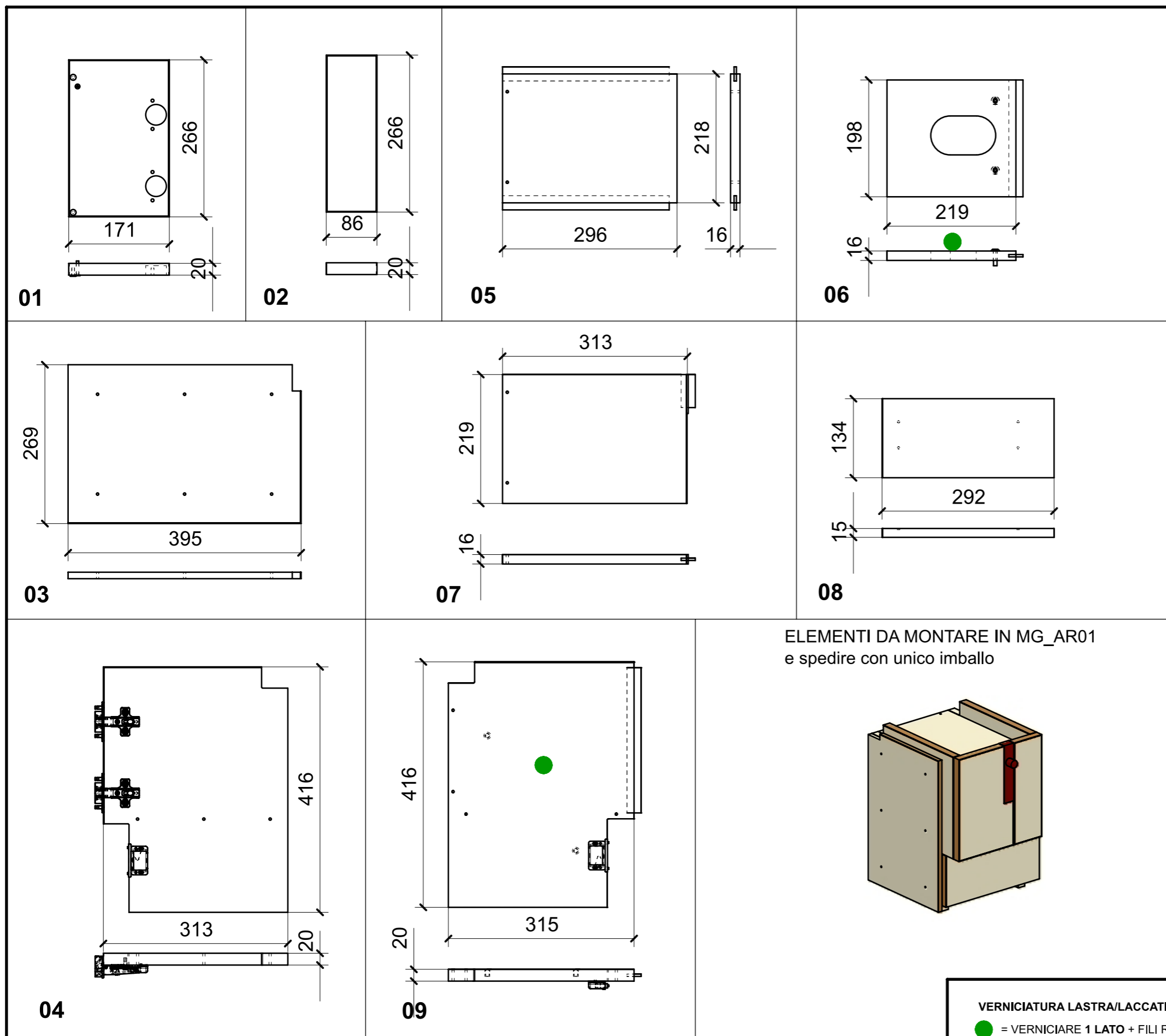

ELEMENTI DA MONTARE IN MG_AR01
e spedire con unico imballo

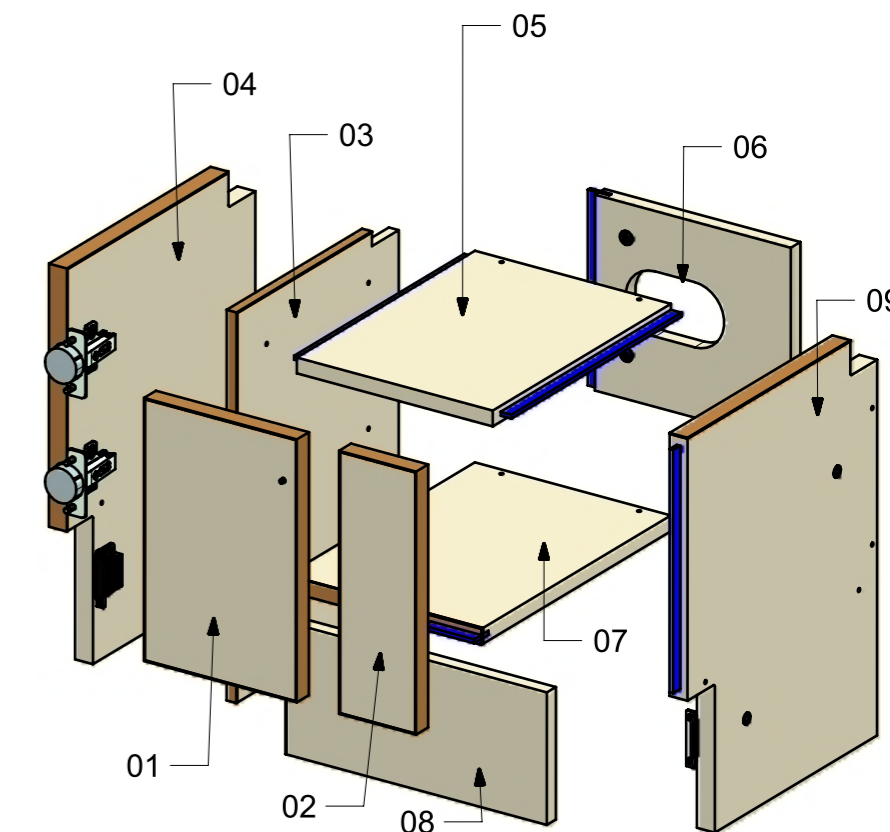
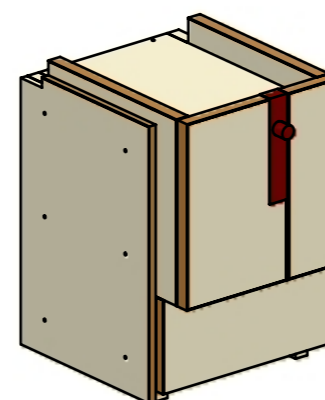

FERRAMENTA	QTY
BASE_0_HAFELE_329_84_020	2
BUSSOLA 5MA ANKOR BORGHI X BASE 0	4
BUSSOLA 5MA ANKOR BORGHI X CERNIERA PIANA	4
BUSSOLA 6MA X 10 FORO DIAM.8	2
CERNIERA 94° PIANA AMMORTIZZATA_HAFELE_329_49_310	2
CHIUSURA A SPINTA_TECHNOPARTNER_SOU C3-203	2
GOMMINO PARACOLPO ANTA	2
VITE 4MA X 25 TESTA SVASATA ESAGONALE NERA	1
VITE 4MAX8 ANKOR BORGHI X BASE 0	4
VITE 4MAX8 ANKOR BORGHI X CERNIERA PIANA	4
VITE 6MA X 25 TESTA BOMBATA	2

VERNICIATURA LASTRA/LACCATI:

● = VERNICIARE 1 LATO + FILI RASATI O BORDATI

NESSUN SIMBOLO = VERNICIARE 2 LATI + FILI RASATI O BORDATI

LOCALE	CODICE	DESCRIZIONE COMPONENTE	FINITURA	Q.TA
CABINA ARMATORE	MD299_R01_AS01	CIELINO	LASTRA SCURA	1

05

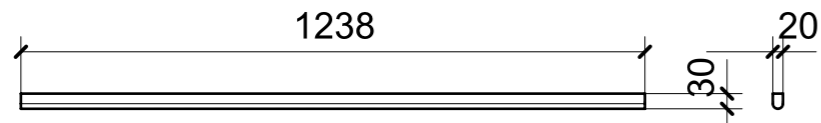

ELEMENTO DA MONTARE CON L01_03 IN MF_AS02
e spedire con unico imballo

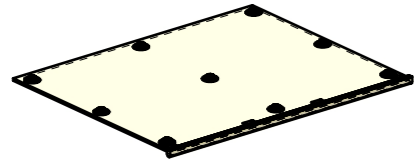

ELEMENTI DA MONTARE CON L01_01/02 IN MF_AS01
e spedire con unico imballo

02

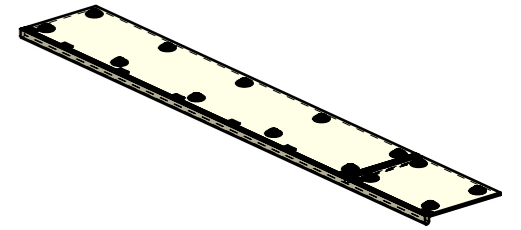
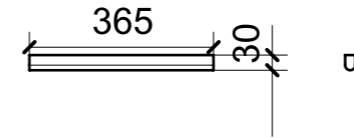

03

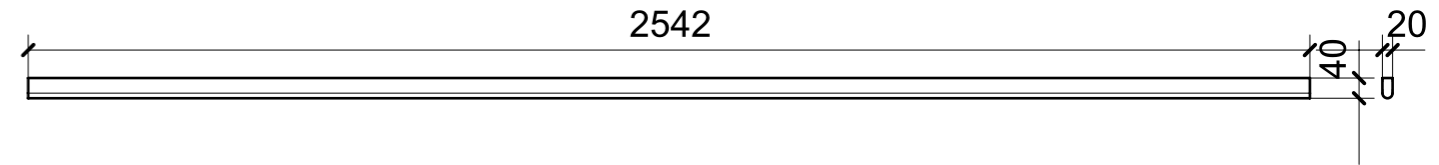

06

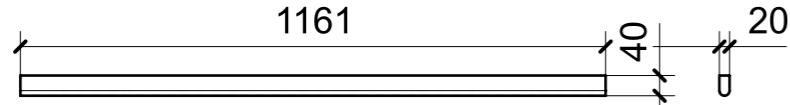

ELEMENTO DA MONTARE CON R01_06 IN MF_AS03
e spedire con unico imballo

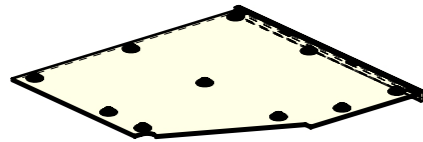

01

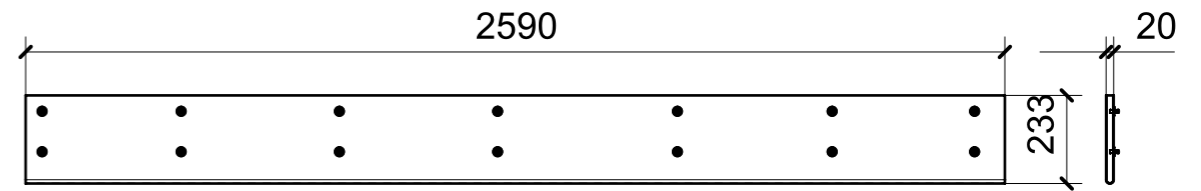

07

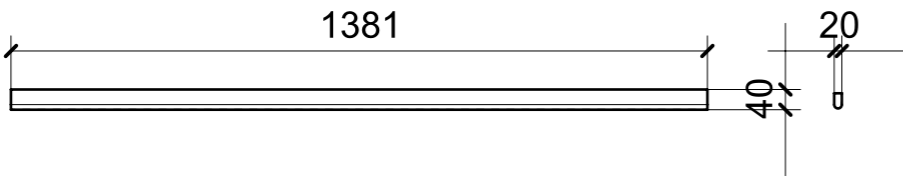

08

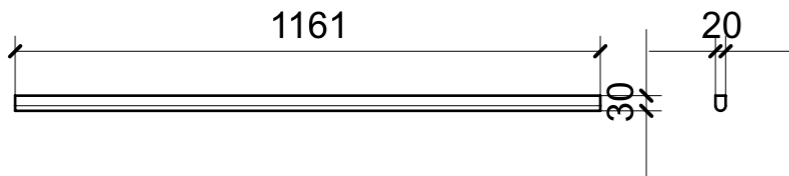

ELEMENTI DA MONTARE CON L01_05 IN MF_AS04
e spedire con unico imballo

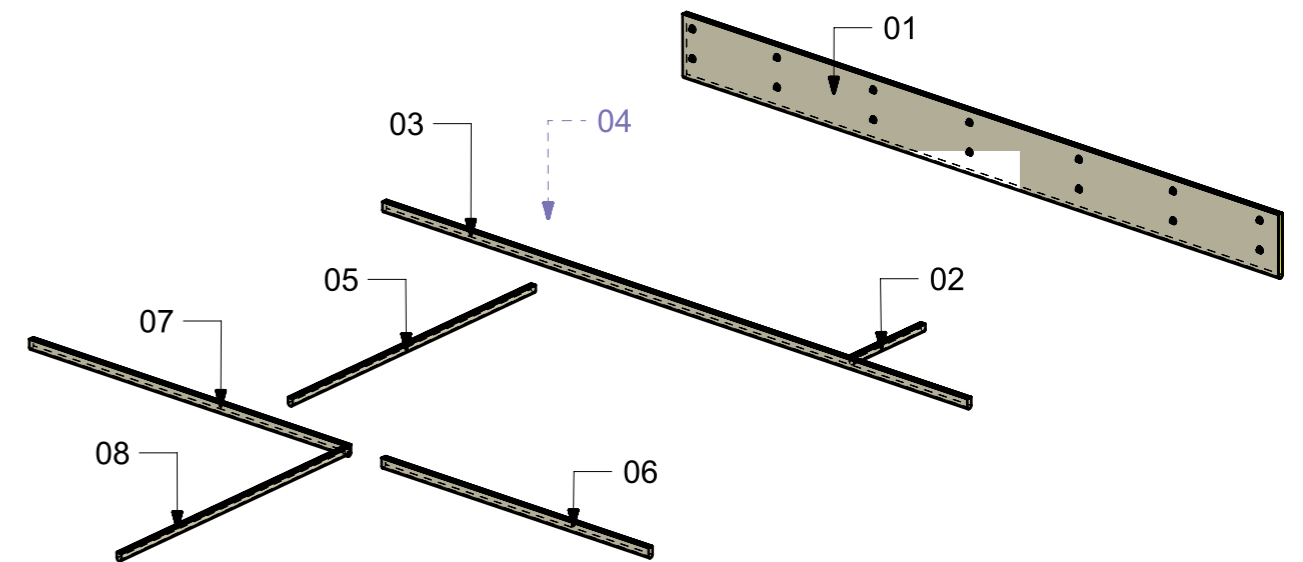
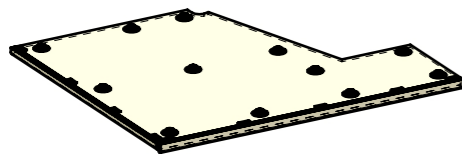

FERRAMENTA	QTY
MS INCASSO_ITALVIPLA_972_FMPC_M1B	14

VERNICIATURA LASTRA/LACCATI:

● = VERNICIARE 1 LATO + FILI RASATI O BORDATI

NESSUN SIMBOLO = VERNICIARE 2 LATI + FILI RASATI O BORDATI

LOCALE	CODICE	DESCRIZIONE COMPONENTE	FINITURA	Q.TA
CABINA ARMATORE	MD299_R01_AW01	RIV.BAGNO OSPITI DX_STD VAR 1 CON VANITY	LASTRA SCURA	1

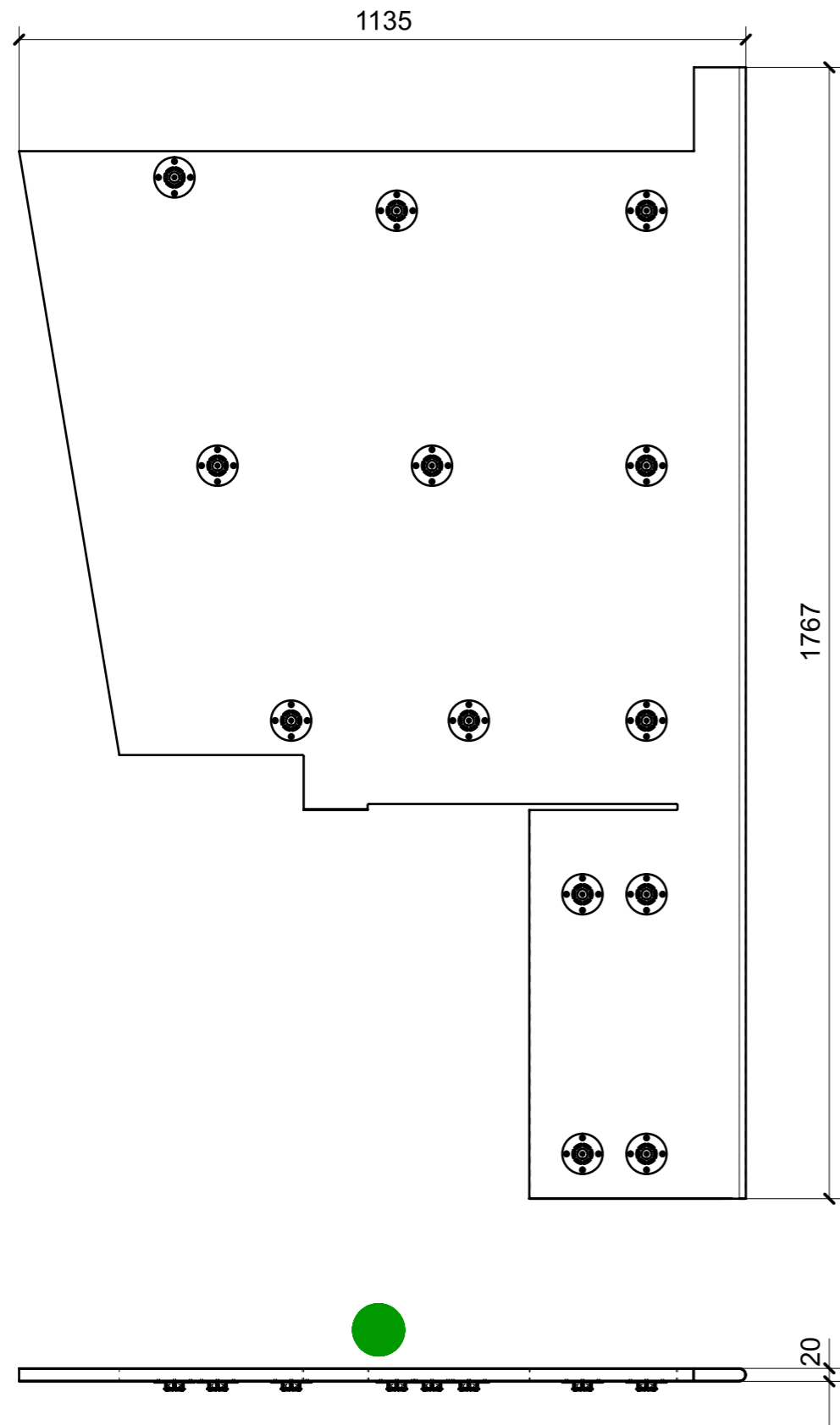

01

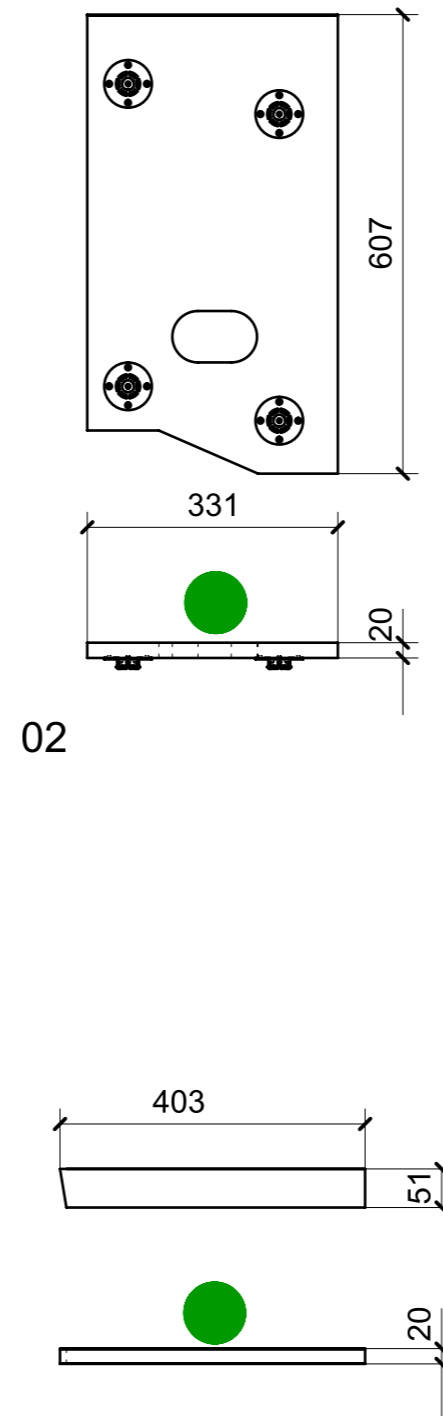

02

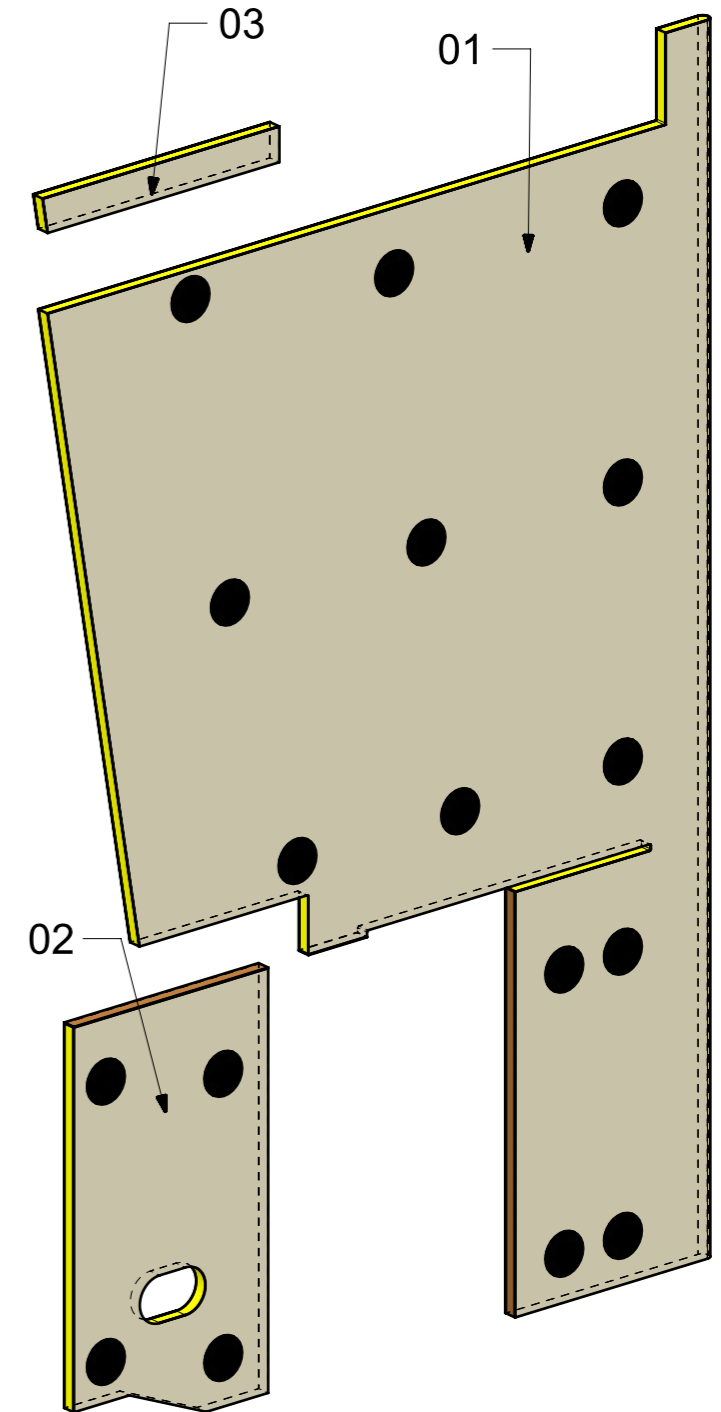

FERRAMENTA	QTY
FITLOCK M_MASCHERPA_3MM_6020202101	17

VERNICIATURA LASTRA/LACCATI:

● = VERNICIARE 1 LATO + FILI RASATI O BORDATI

NESSUN SIMBOLO = VERNICIARE 2 LATI + FILI RASATI O BORDATI

LOCALE	CODICE	DESCRIZIONE COMPONENTE	FINITURA	GR.
CABINA ARMATORE	MD299_R01_AAQ01	COMODINO SX_STD VAR 2	LASTRA SCURA	16

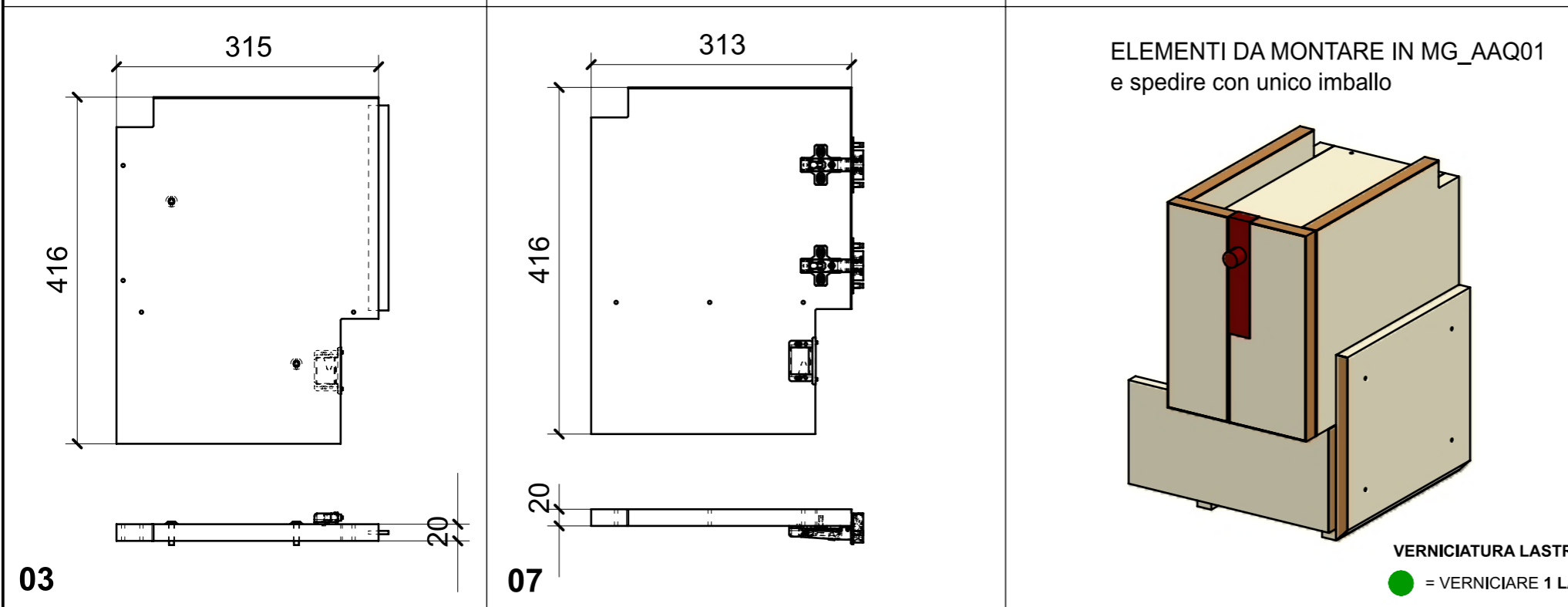
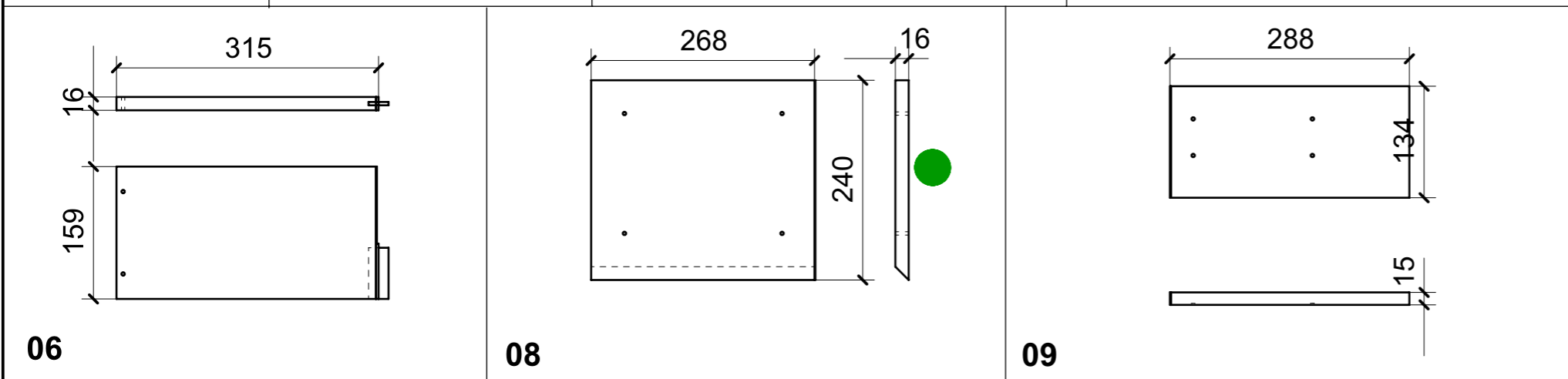
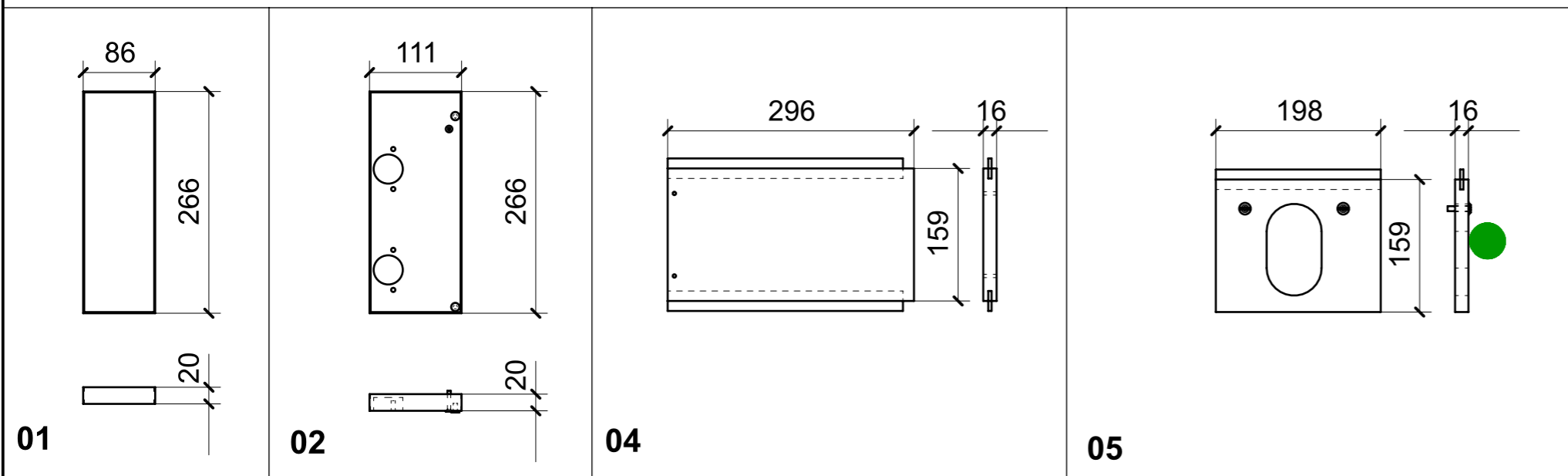

ELEMENTI DA MONTARE IN MG_AAQ01
e spedire con unico imballo

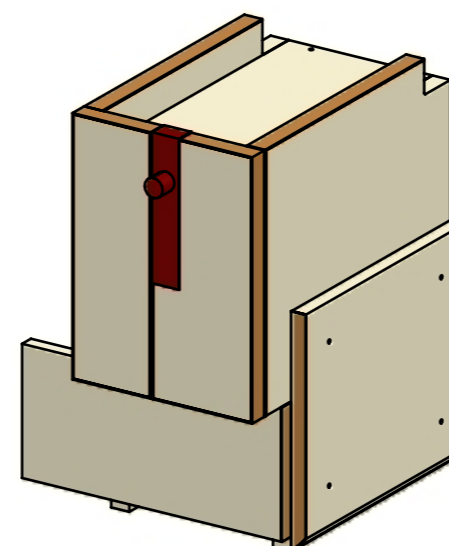

VERNICIATURA LASTRA/LACCATI:

● = VERNICIARE 1 LATO + FILI RASATI O BORDATI

NESSUN SIMBOLO = VERNICIARE 2 LATI + FILI RASATI O BORDATI

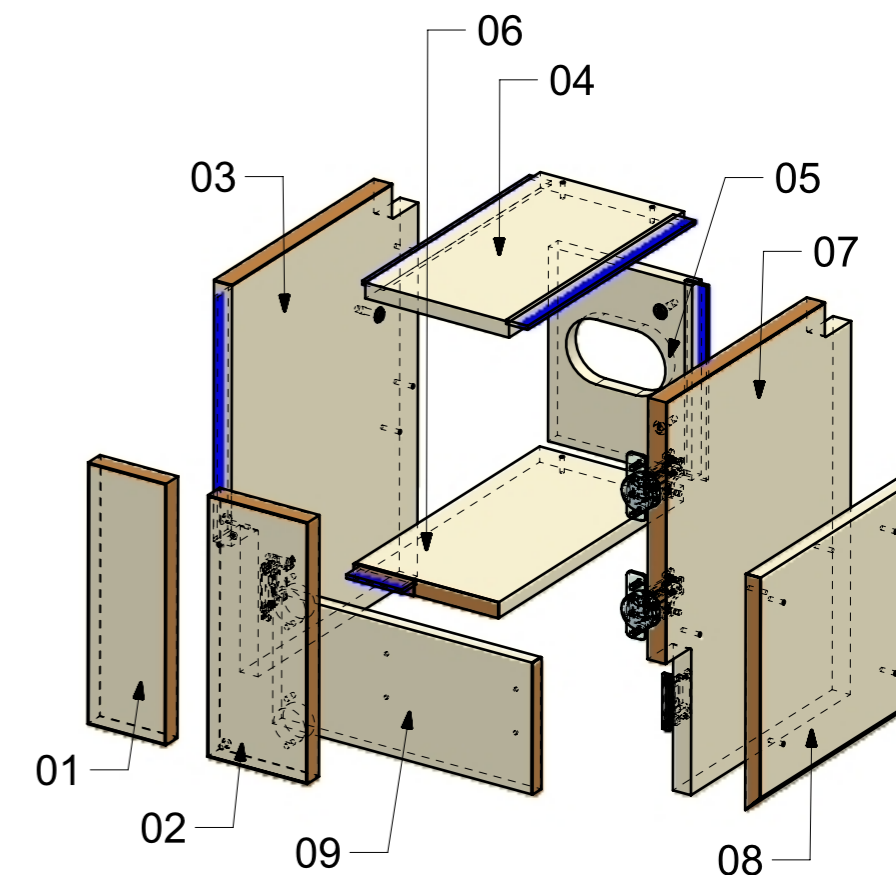

FERRAMENTA	QTY
BASE_0_HAFELE_329_84_020	2
BUSSOLA 5MA ANKOR BORGHI X BASE 0	4
BUSSOLA 5MA ANKOR BORGHI X CERNIERA PIANA	4
CERNIERA 94° PIANA AMMORTIZZATA_HAFELE_329_49_310	2
CHIUSURA A SPINTA_TECHNOPARTNER_SOU C3-203	2
GOMMINO PARACOLPO ANTA	2
VITE 4MA X 25 TESTA SVASATA ESAGONALE NERA	1
VITE 4MAX8 ANKOR BORGHI X BASE 0	4
VITE 4MAX8 ANKOR BORGHI X CERNIERA PIANA	4
VITE 6MA X 25 TESTA BOMBATA	4

LOCALE	CODICE	DESCRIZIONE COMPONENTE	FINITURA	GR.
CABINA ARMATORE	MD299_R01_AAR01	COMODINO DX_STD VAR 2	LASTRA SCURA	16

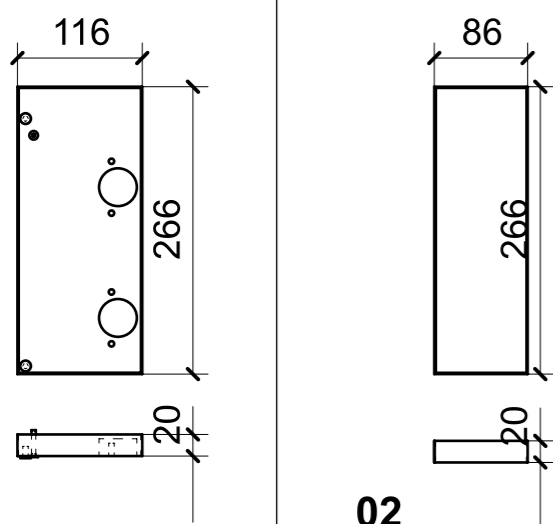

01

02

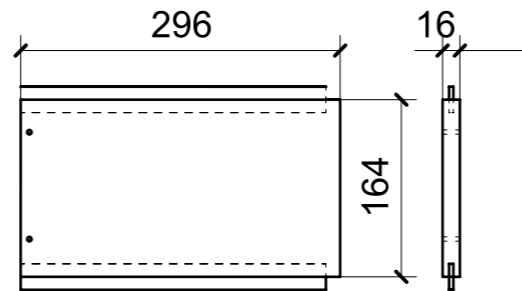

05

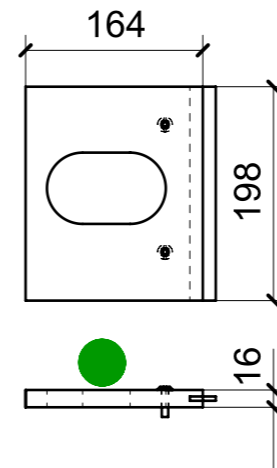

06

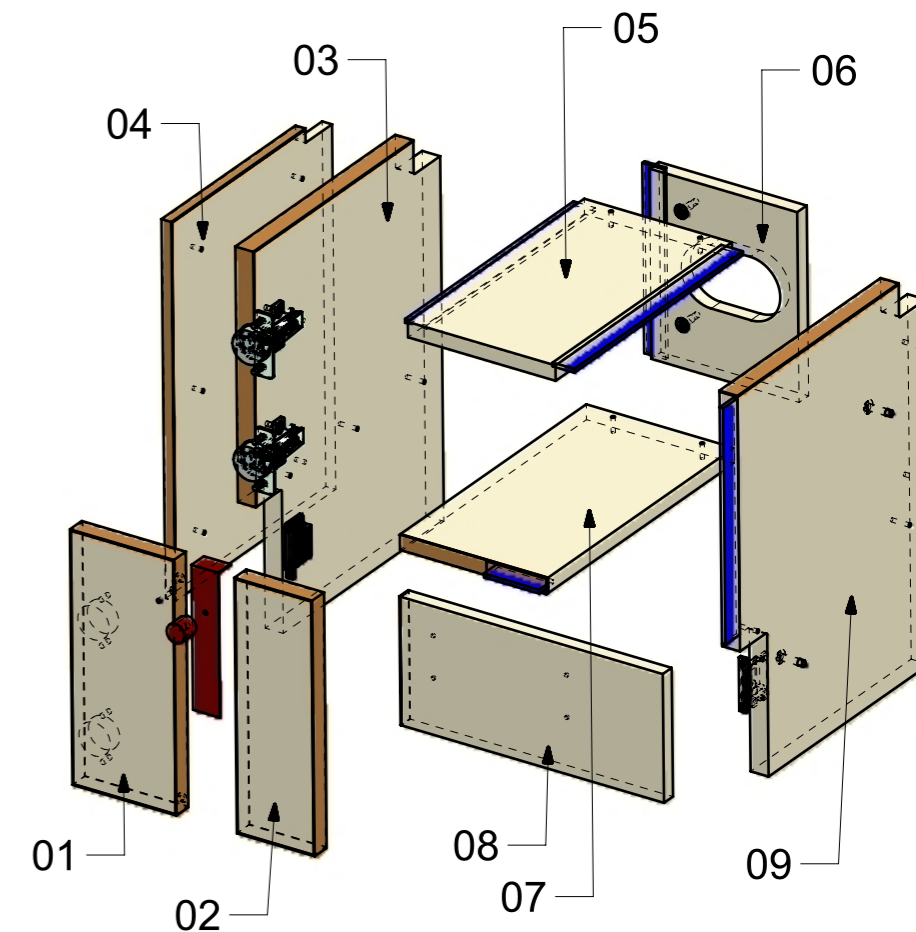

01

02

08

07

09

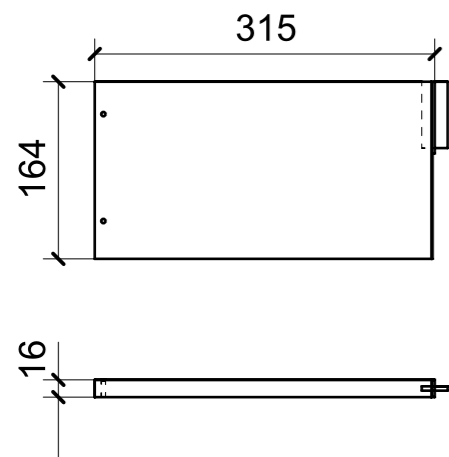

07

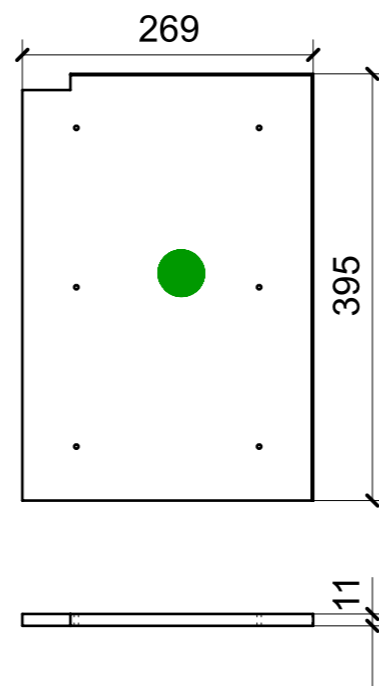

04

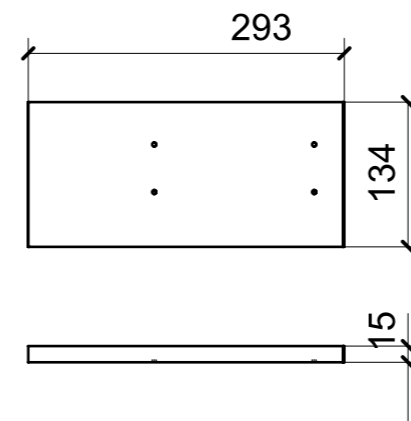

08

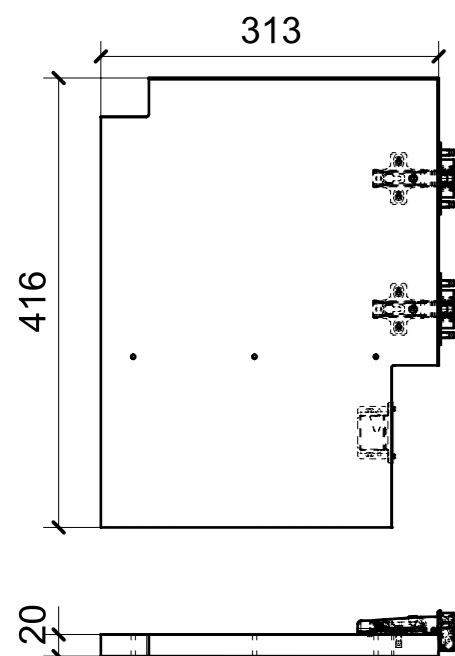

03

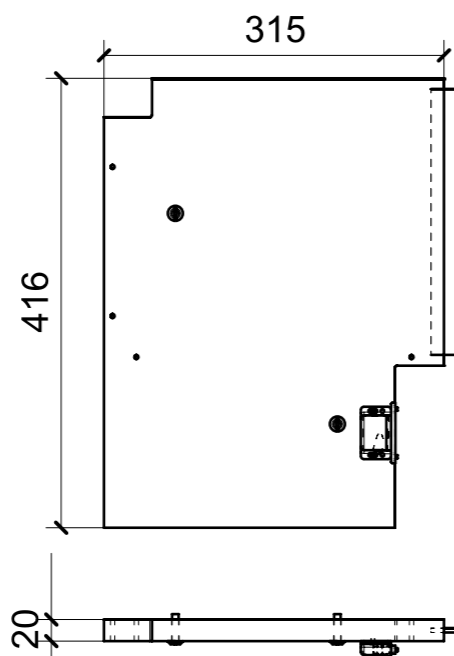

09

ELEMENTI DA MONTARE IN MG_AAR01
e spedire con unico imballo

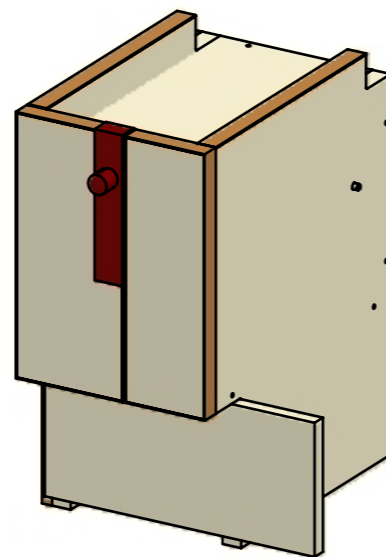

VERNICIATURA LASTRA/LACCATI:

● = VERNICIARE 1 LATO + FILI RASATI O BORDATI

NESSUN SIMBOLO = VERNICIARE 2 LATI + FILI RASATI O BORDATI

FERRAMENTA	QTY
BASE_0_HAFELE_329_84_020	2
BUSSOLA 5MA ANKOR BORGHI X BASE 0	4
BUSSOLA 5MA ANKOR BORGHI X CERNIERA PIANA	4
CERNIERA 94° PIANA AMMORTIZZATA_HAFELE_329_49_310	2
CHIUSURA A SPINTA_TECHNOPARTNER_SOU C3-203	2
GOMMINO PARACOLPO ANTA	2
VITE 4MA X 25 TESTA SVASATA ESAGONALE NERA	1
VITE 4MAX8 ANKOR BORGHI X BASE 0	4
VITE 4MAX8 ANKOR BORGHI X CERNIERA PIANA	4
VITE 6MA X 25 TESTA BOMBATA	4