

LOCALE	CODICE	DESCRIZIONE COMPONENTE	FINITURA	Q.TA
CABINA VIP	MD299_I01_VA01	LETTO	OKUME' GREZZO	3

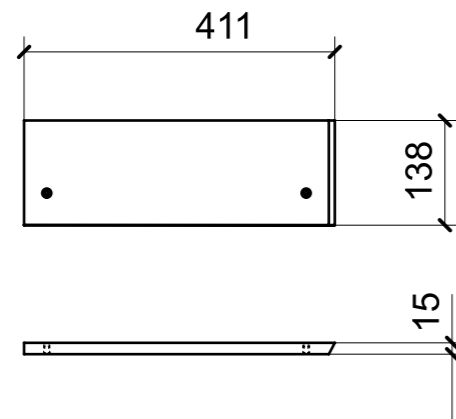

01

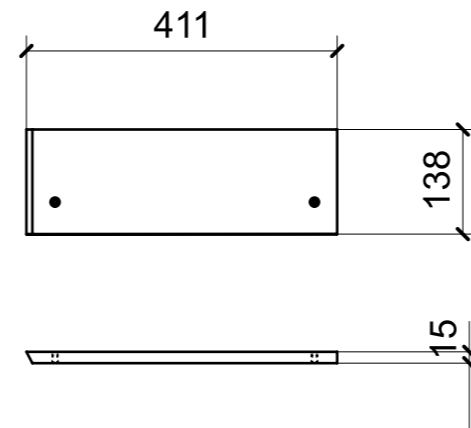

03

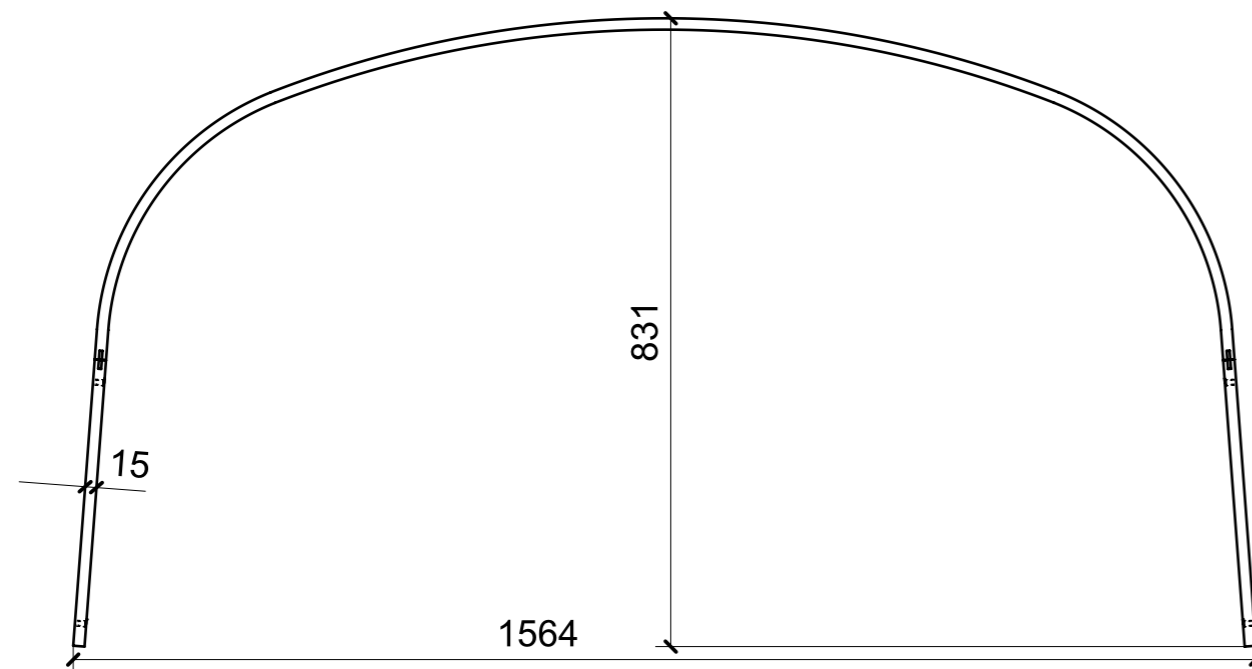
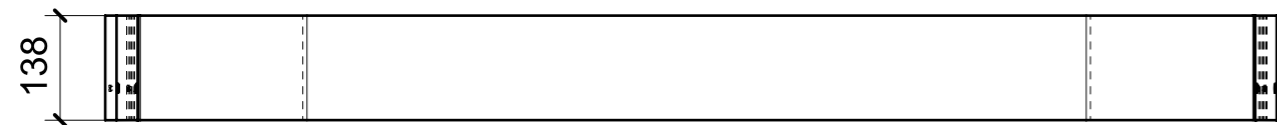
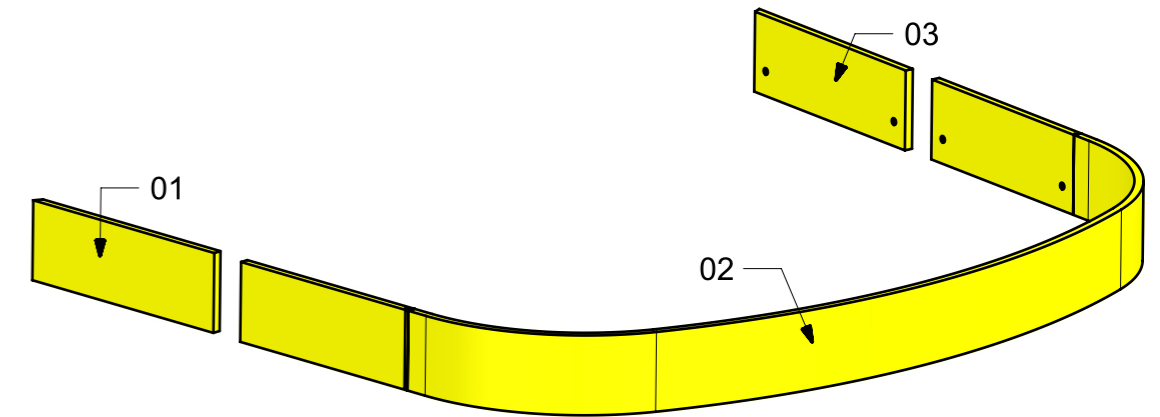

02

FERRAMENTA	QTY
BUSSOLA 5MA X 10 FORO DIAM.8	8

LOCALE	CODICE	DESCRIZIONE COMPONENTE	FINITURA	Q.TA
CABINA VIP	MD299_I01_VB01	COMODINI	OKUME' GREZZO	1

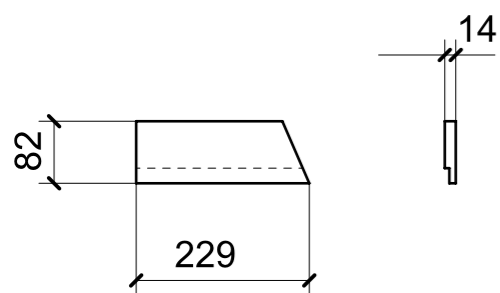

01

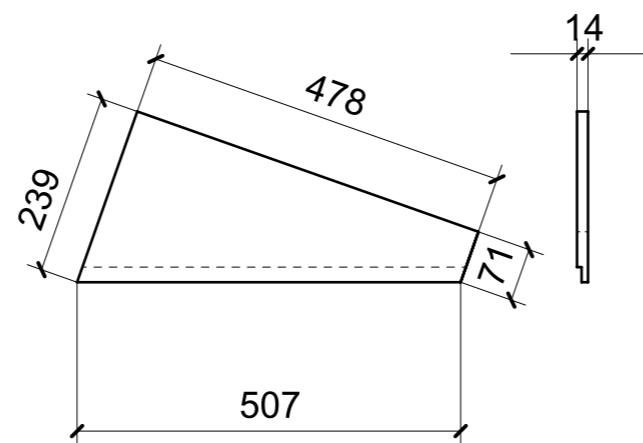

02

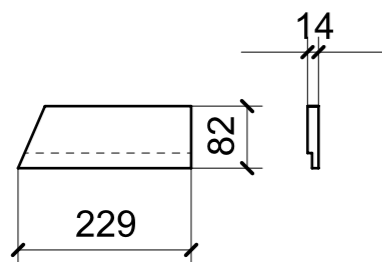
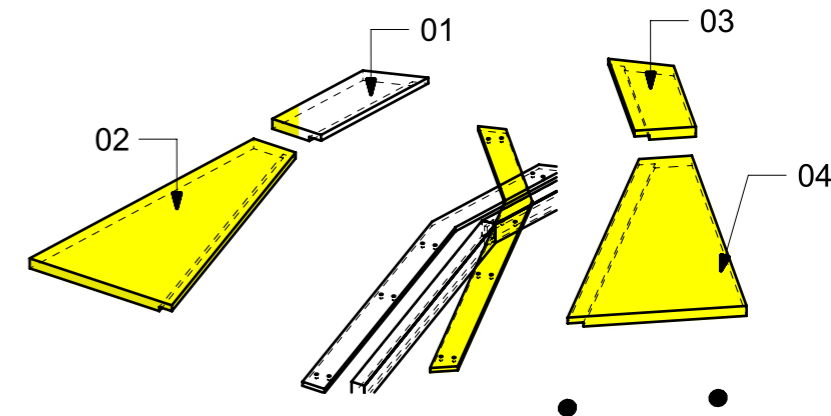

03

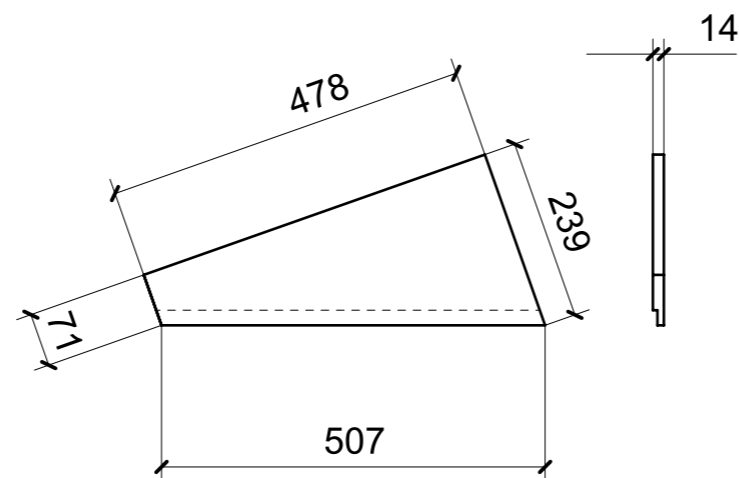

04

LOCALE	CODICE	DESCRIZIONE COMPONENTE	FINITURA	Q.TA
CABINA VIP	MD299_I01_VC01	COLLEGAMENTO MURA DX	OKUME' GREZZO	1

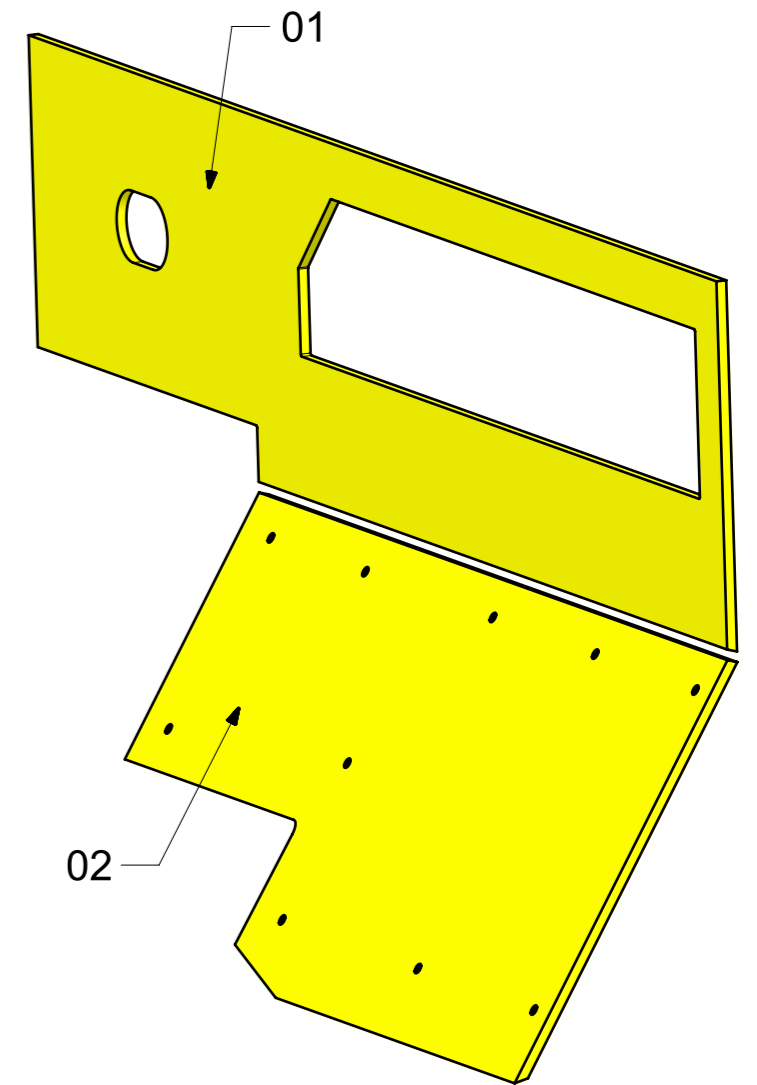
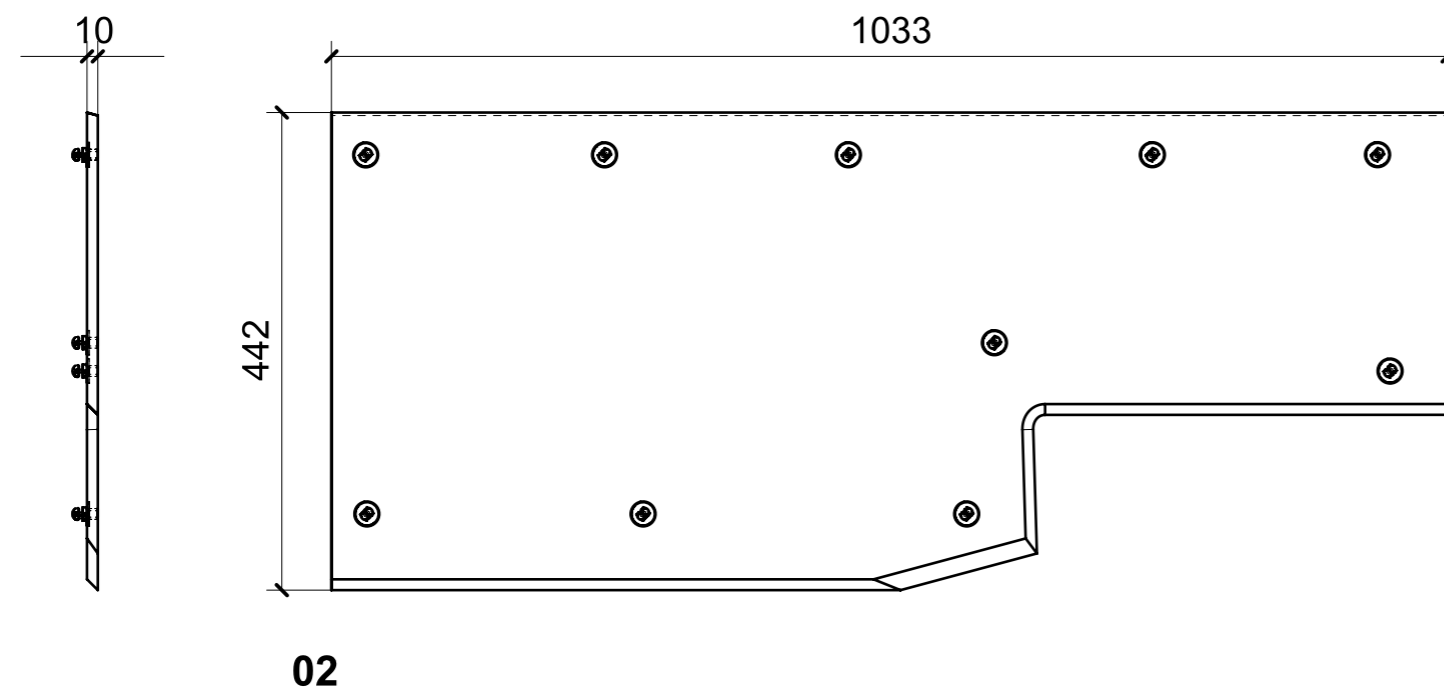
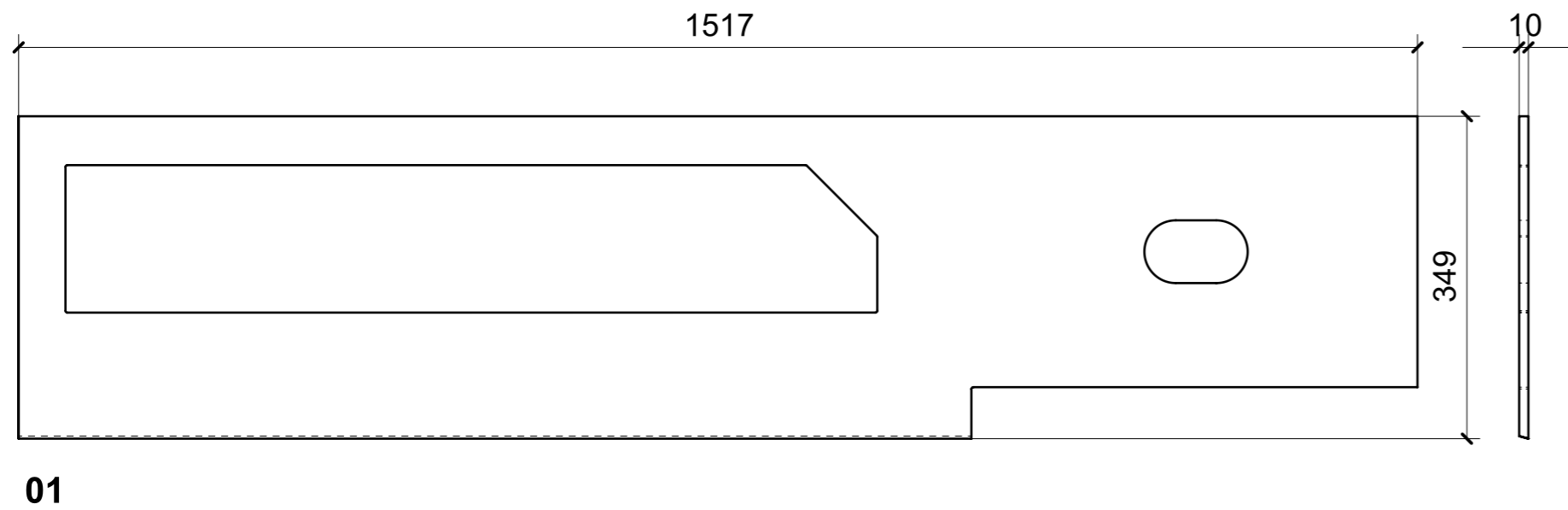

FERRAMENTA	QTY
MS INCASSO_ITALVIPLA_972_FMPC_M1B	10

LOCALE	CODICE	DESCRIZIONE COMPONENTE	FINITURA	Q.TA
CABINA VIP	MD299_I01_VD01	COLLEGAMENTO MURA SX	OKUME' GREZZO	1

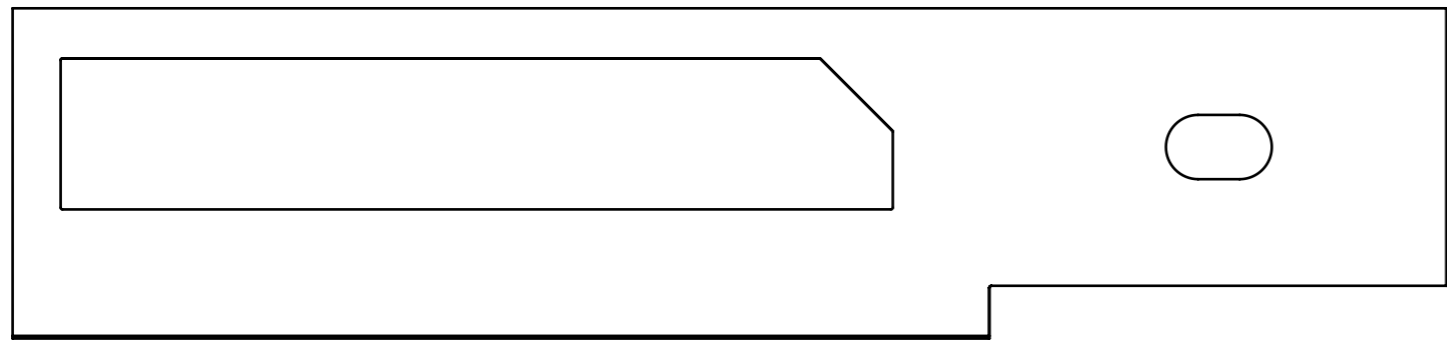

01

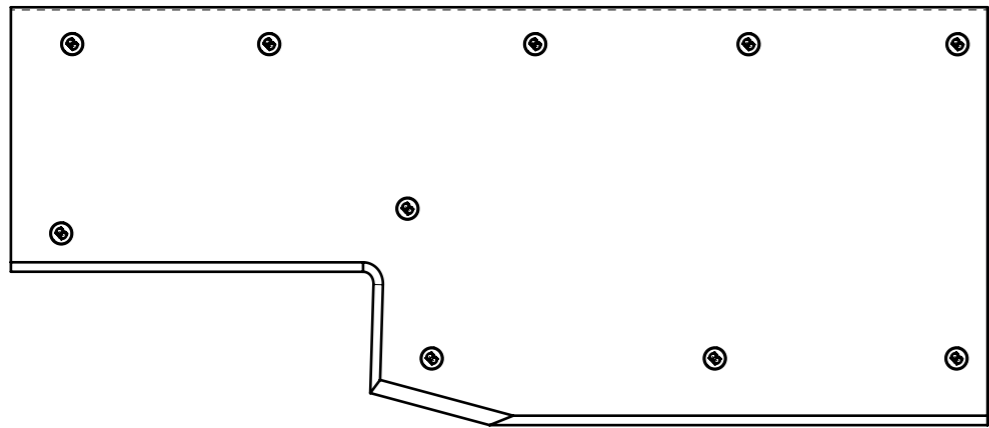

02

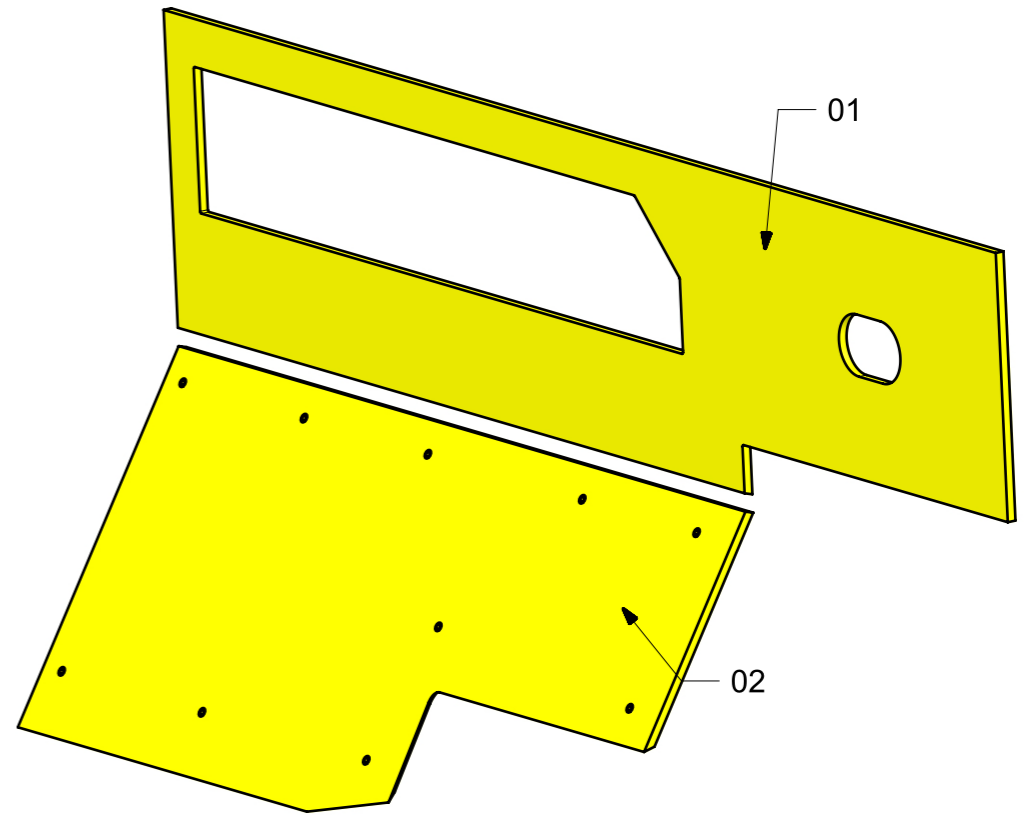

FERRAMENTA	QTY
MS INCASSO_ITALVIPLA_972_FMPC_M1B	10

LOCALE	CODICE	DESCRIZIONE COMPONENTE	FINITURA	Q.TA
CABINA VIP	MD299_I01_VG01	ARMADIO SX	OKUME' GREZZO	1

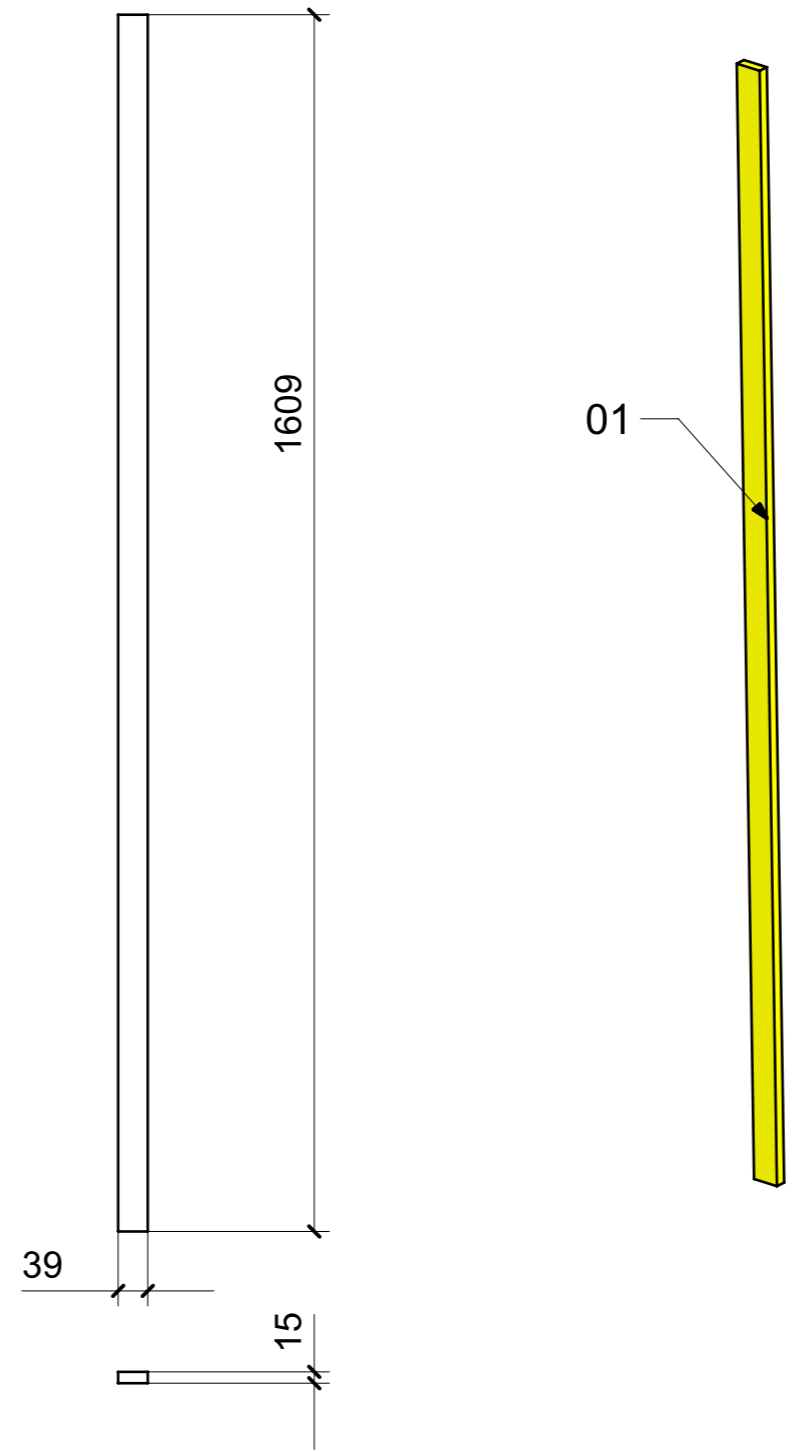

LOCALE	CODICE	DESCRIZIONE COMPONENTE	FINITURA	Q.TA
CABINA VIP	MD299_I01_VI01	PENSILE SX	OKUME' GREZZO	1

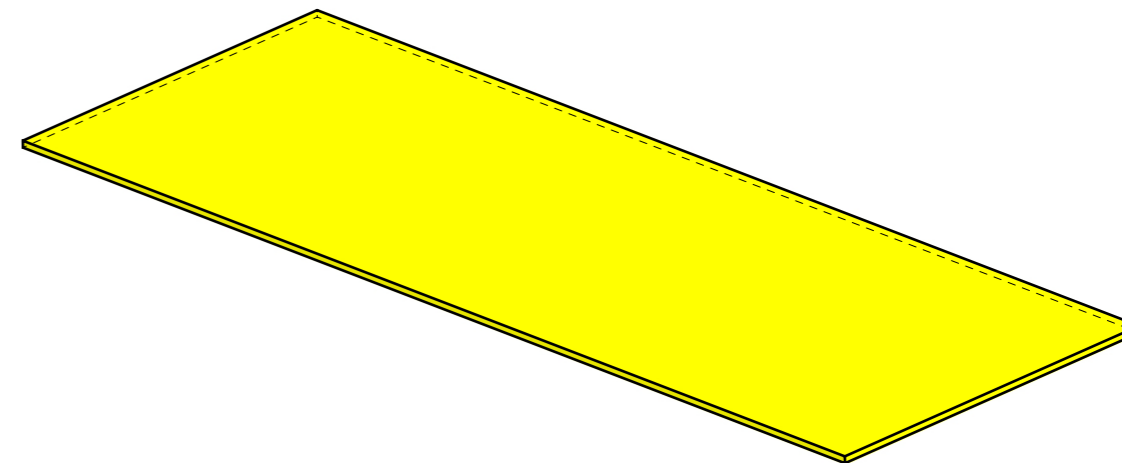
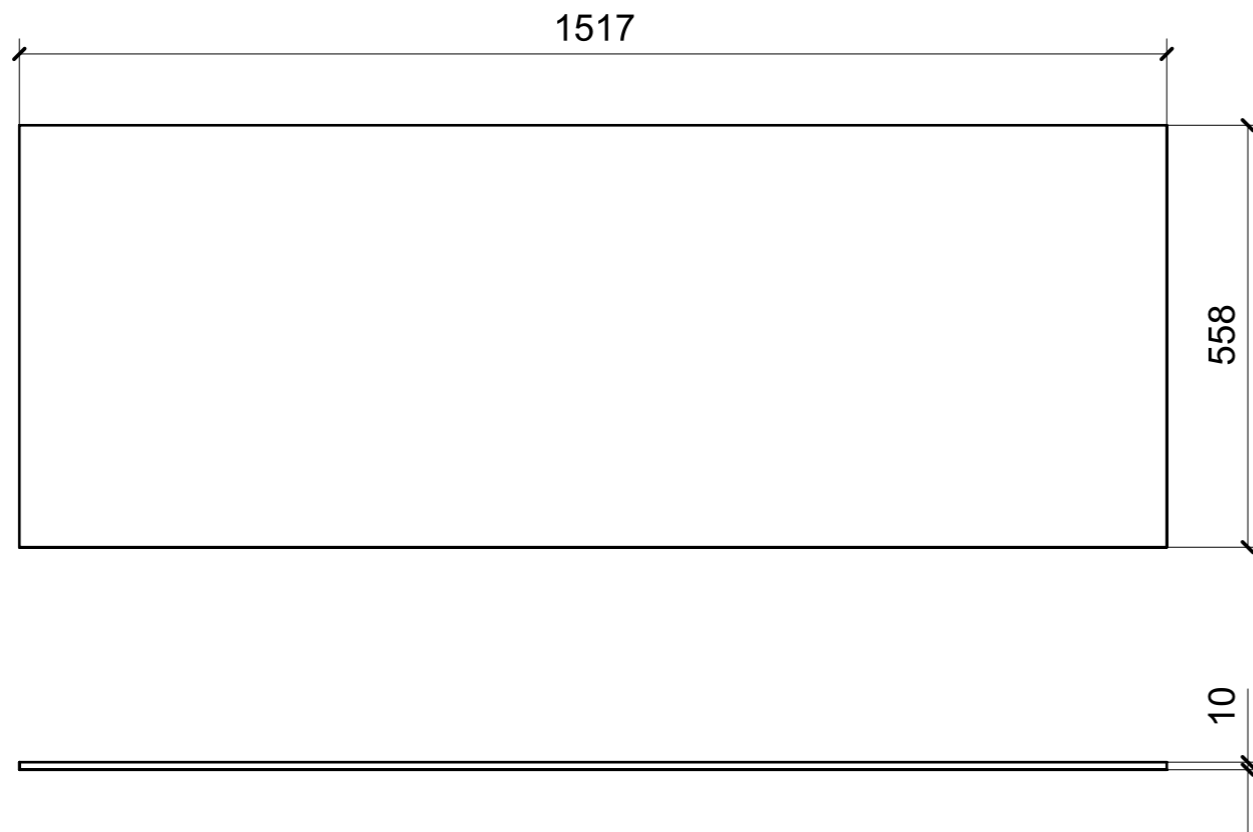

LOCALE	CODICE	DESCRIZIONE COMPONENTE	FINITURA	Q.TA
CABINA VIP	MD299_I01_VL01	PENSILE DX	OKUME' GREZZO	1

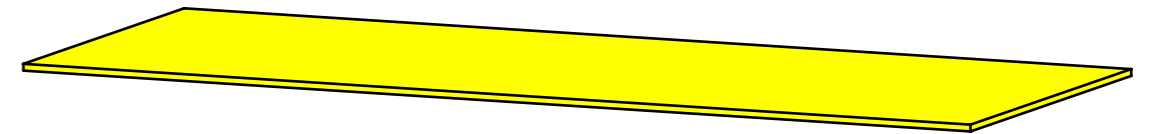
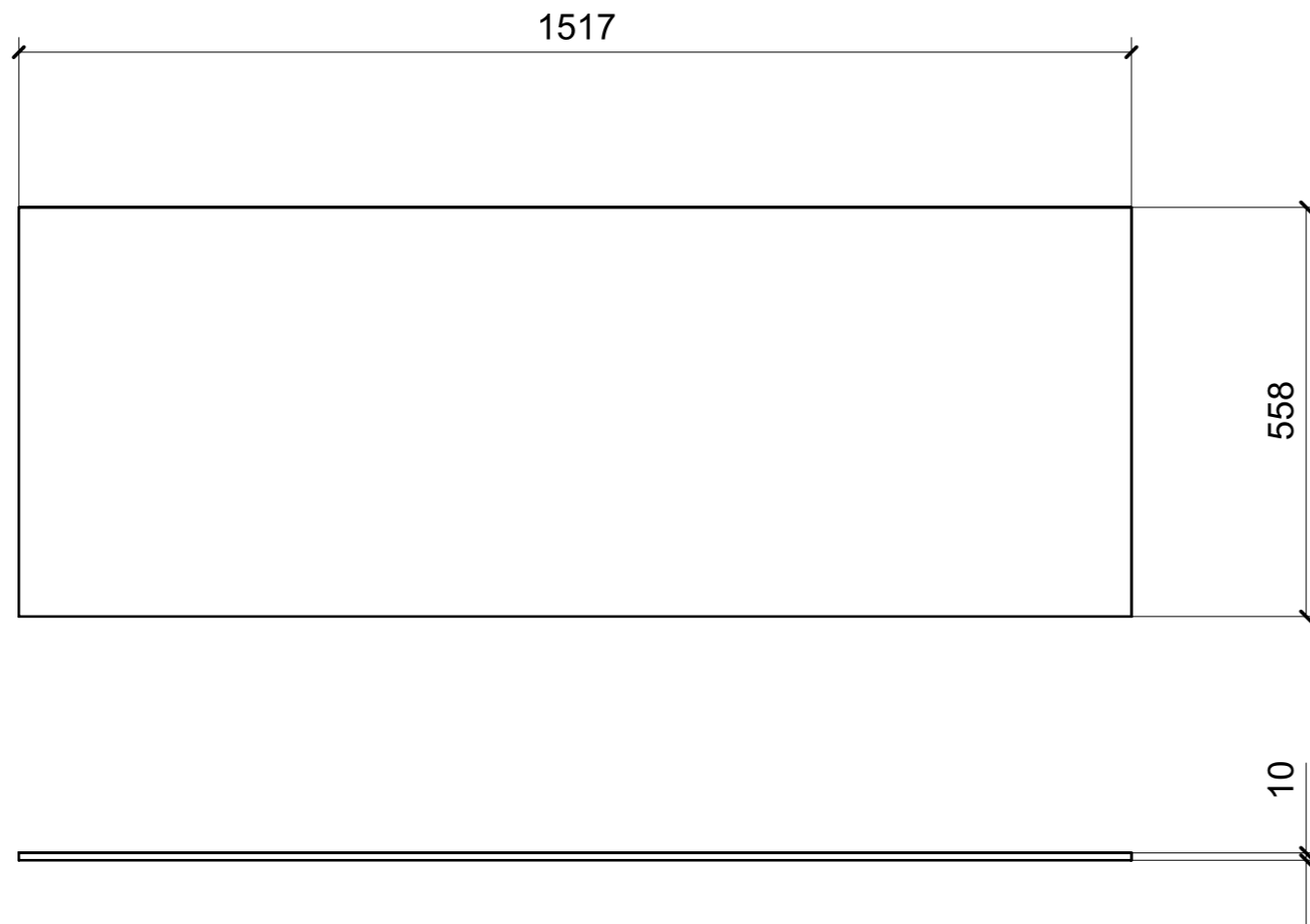

LOCALE	CODICE	DESCRIZIONE COMPONENTE	FINITURA	Q.TA
CABINA VIP	MD299_I01_VM01	RIV. MURATA SX POPPA	OKUME' GREZZO	1

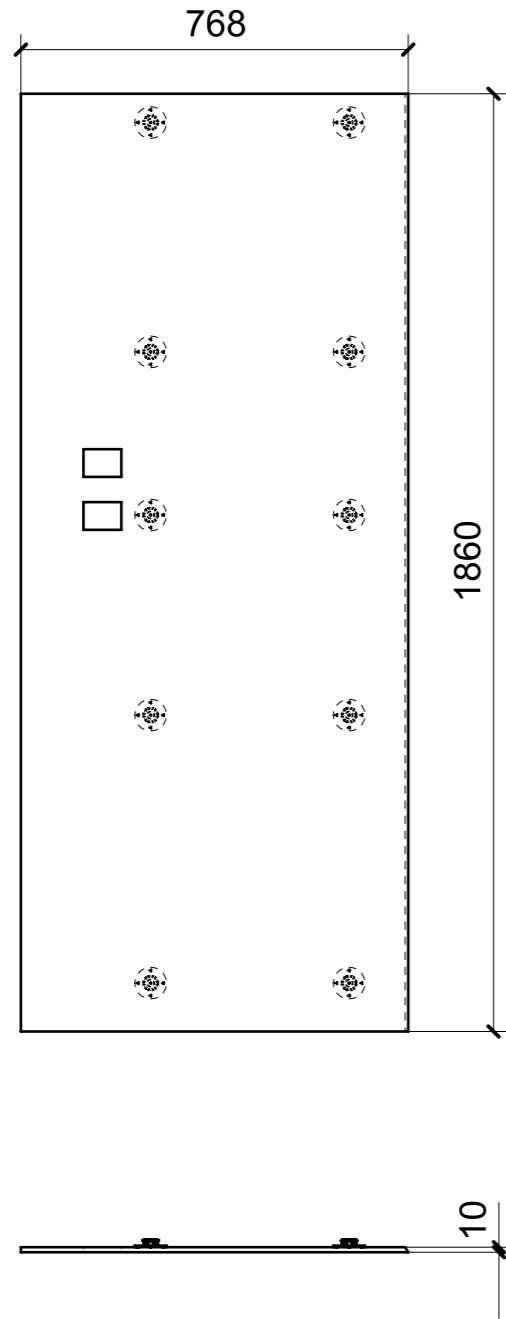

01

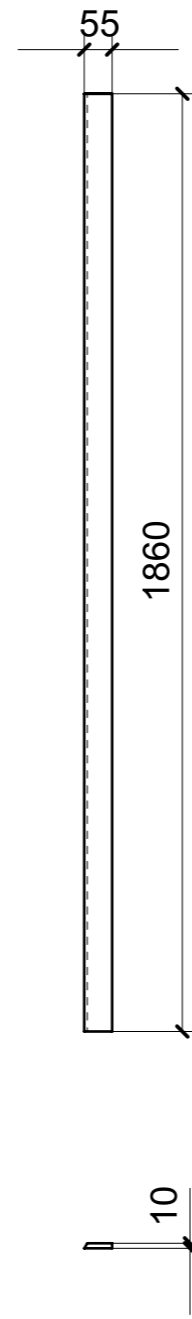

02

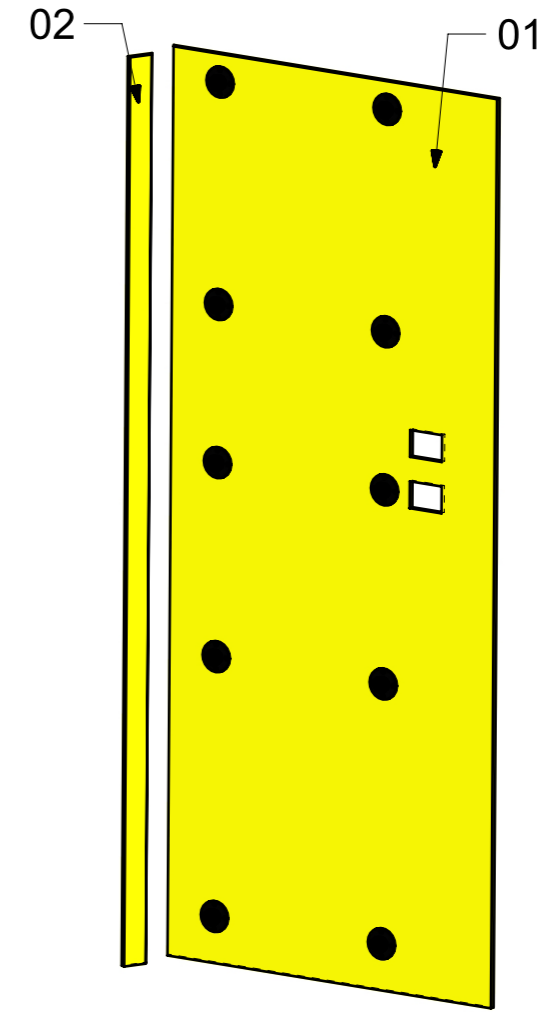

FERRAMENTA	QTY
FITLOCK M_MASCHERPA_3MM_6020202101	10

LOCALE	CODICE	DESCRIZIONE COMPONENTE	FINITURA	Q.TA
CABINA VIP	MD299_I01_VO01	RIVESTIMENTO _STD VAR1 SENZA TV	OKUME' GREZZO	1

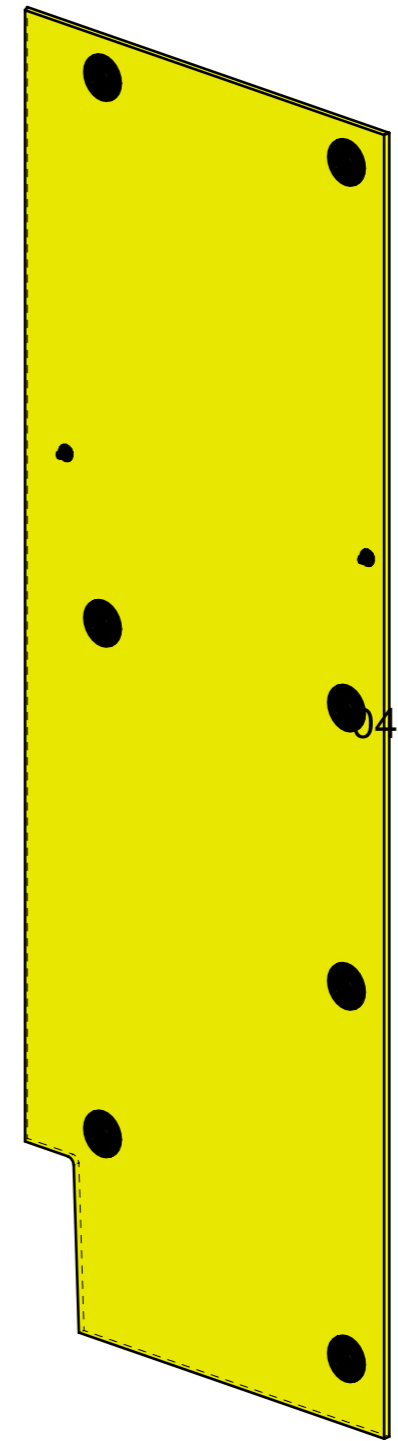
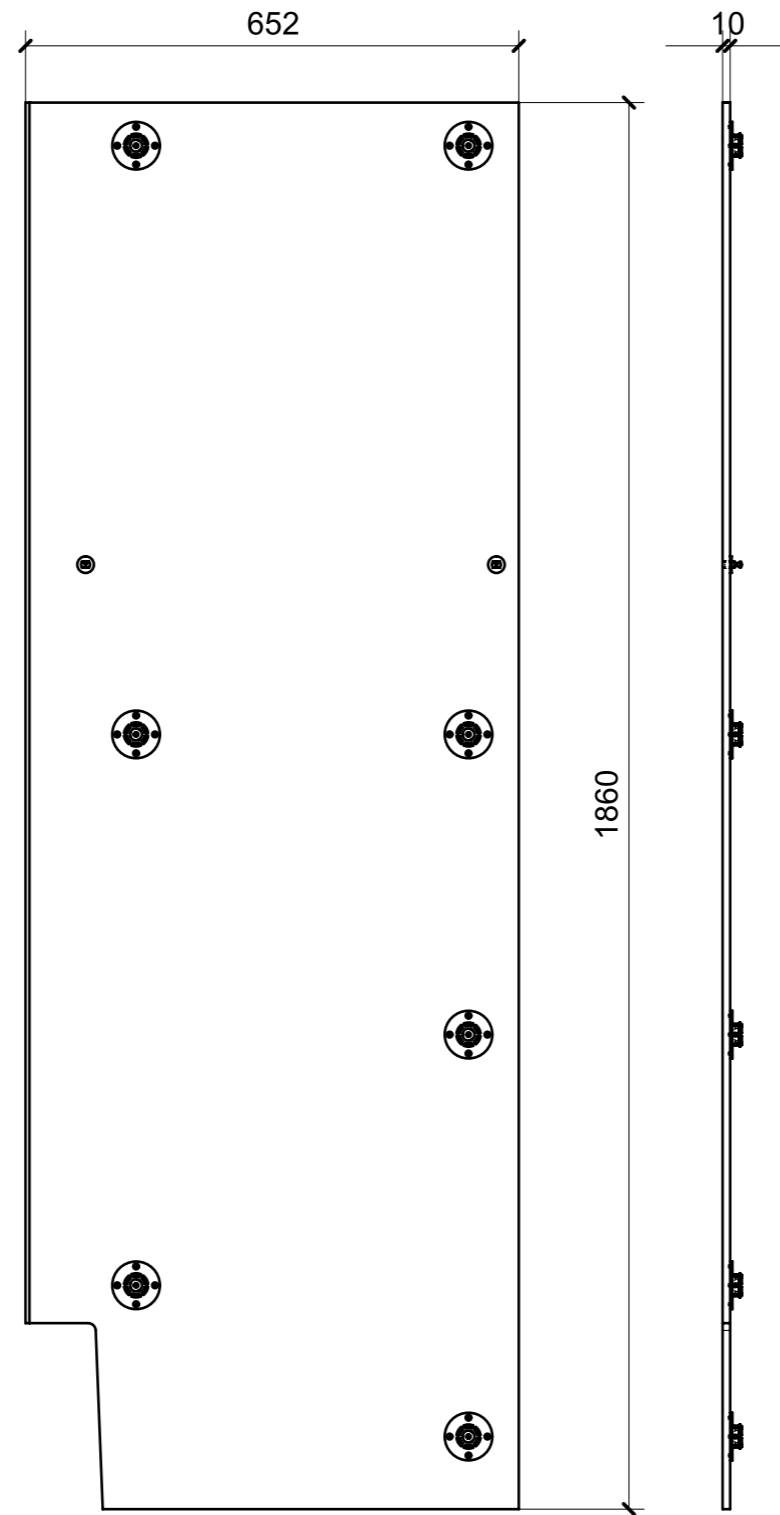

FERRAMENTA	QTY
FITLOCK M_MASCHERPA_3MM_6020202101	7
MS INCASSO_ITALVIPLA_972_FMPC_M1B	2

LOCALE	CODICE	DESCRIZIONE COMPONENTE	FINITURA	Q.TA
CABINA VIP	MD299_I01_VP01	RIVESTIMENTO STD VAR 2 CON TV	OKUME' GREZZO	1

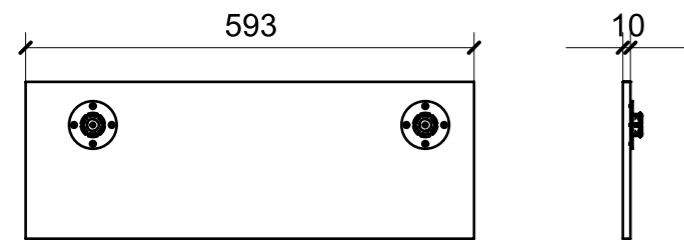

01

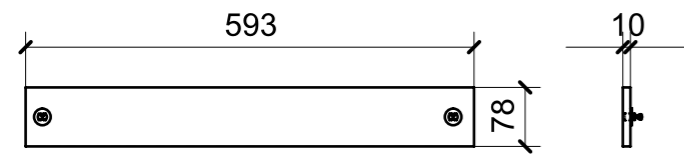

02

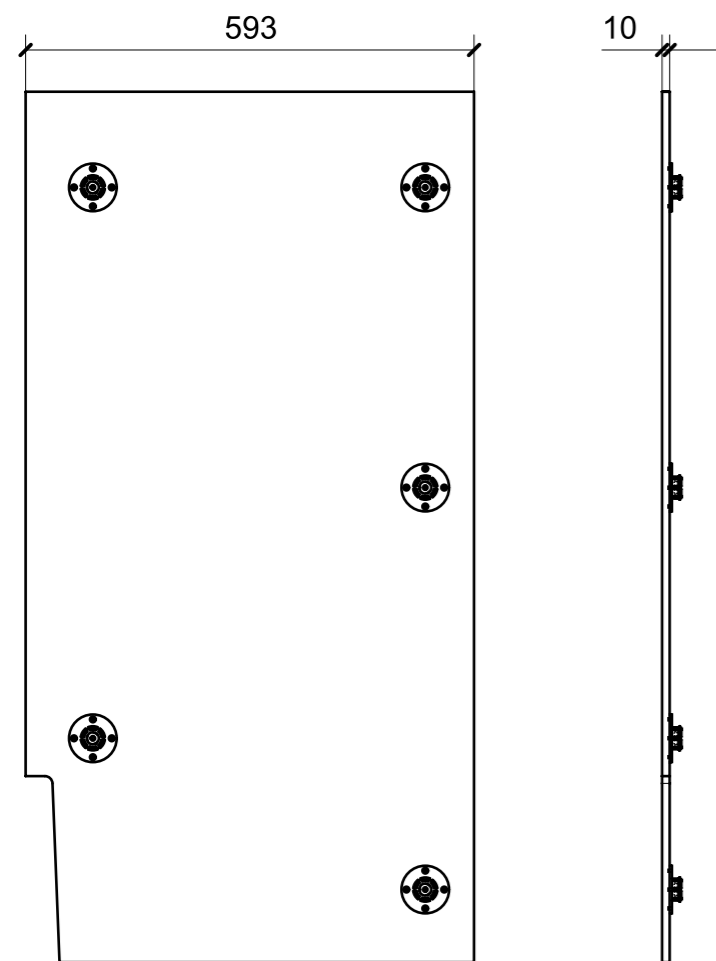

03

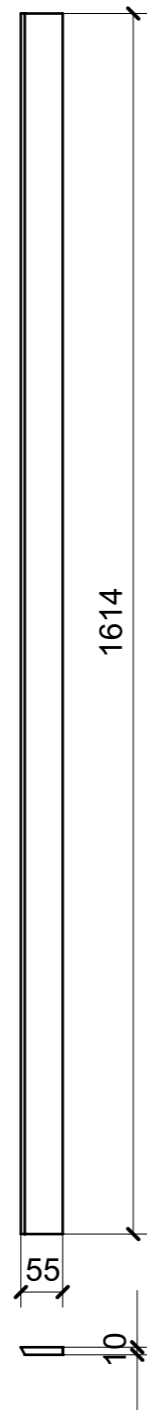

04

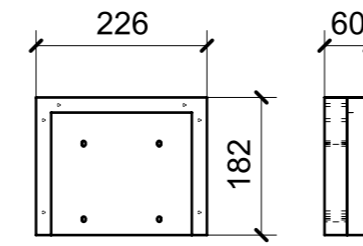

05

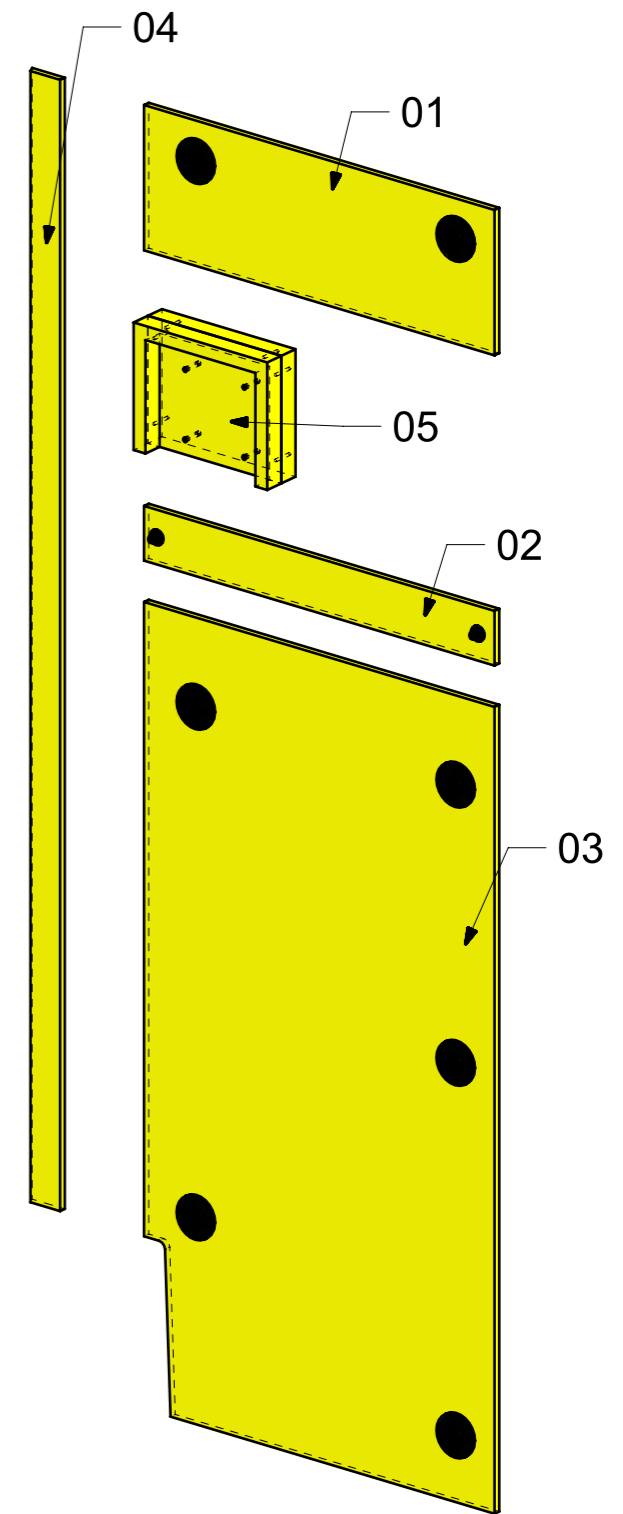

FERRAMENTA	QTY
MS INCASSO_ITALVIPLA_972_FMPC_M1B	2
FITLOCK M_MASCHERPA_3MM_6020202101	7

LOCALE	CODICE	DESCRIZIONE COMPONENTE	FINITURA	Q.TA
CABINA VIP	MD299_I01_VQ01	CIELINO	OKUME' GREZZO	1

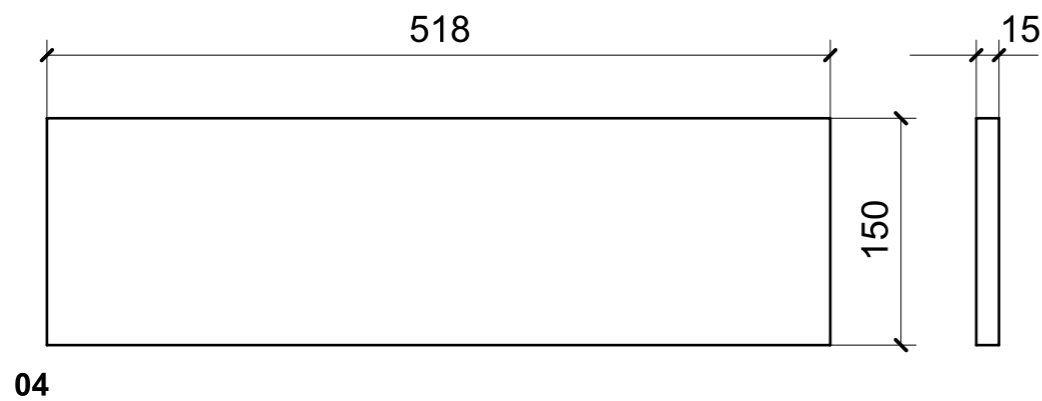
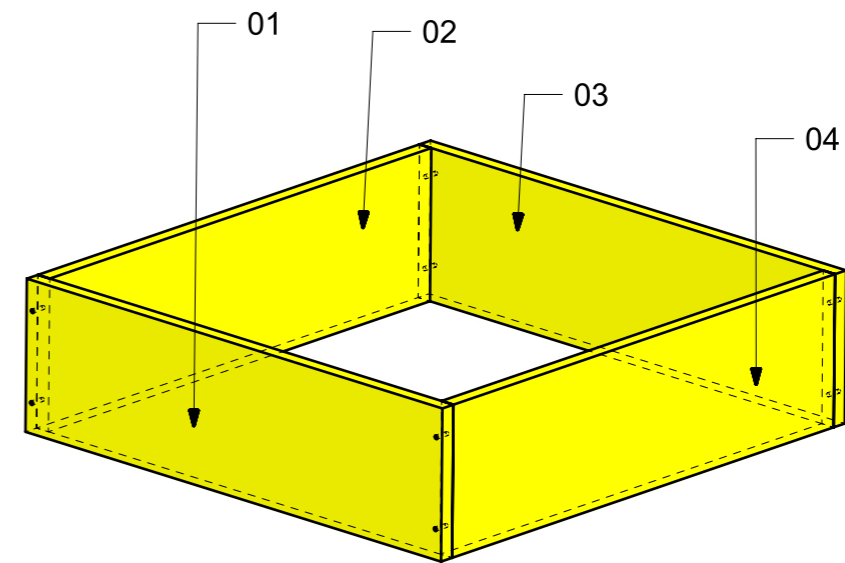
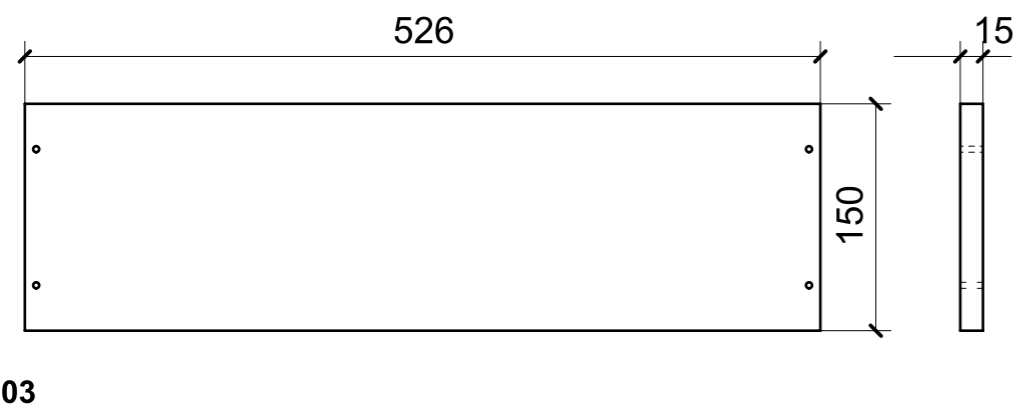
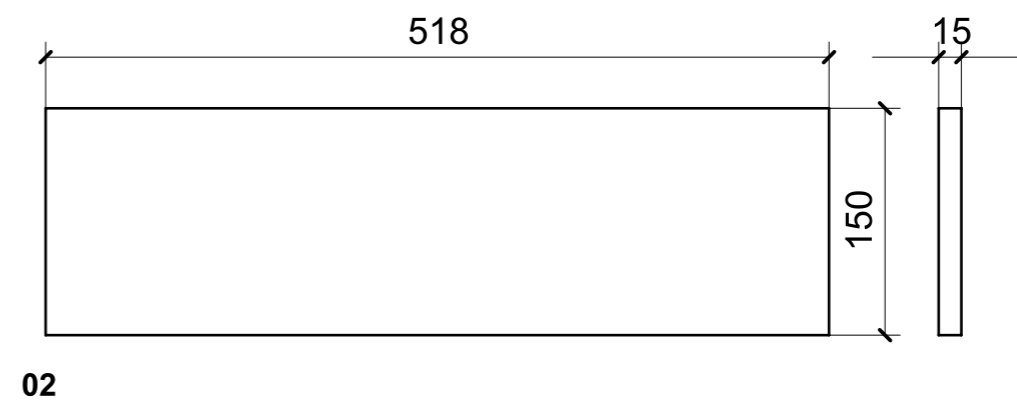
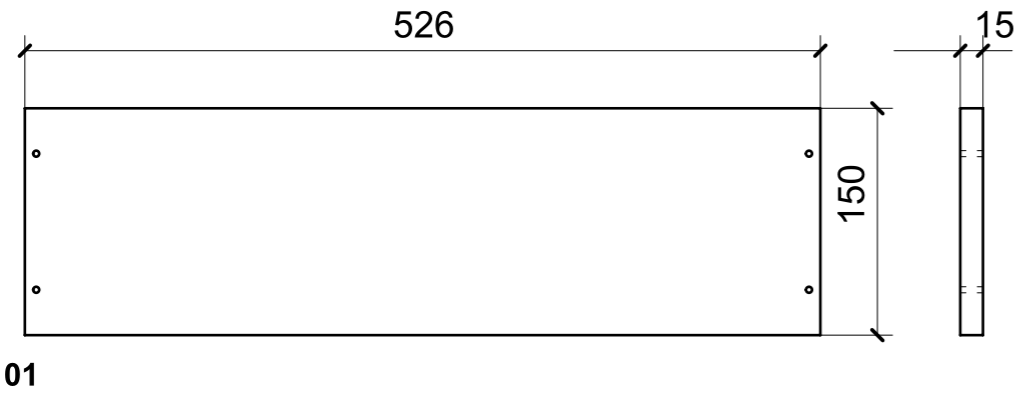

LOCALE	CODICE	DESCRIZIONE COMPONENTE	FINITURA	Q.TA
CABINA VIP	MD299_I01_VS01	RIV.PARETE DX POPPA	OKUME' GREZZO	1

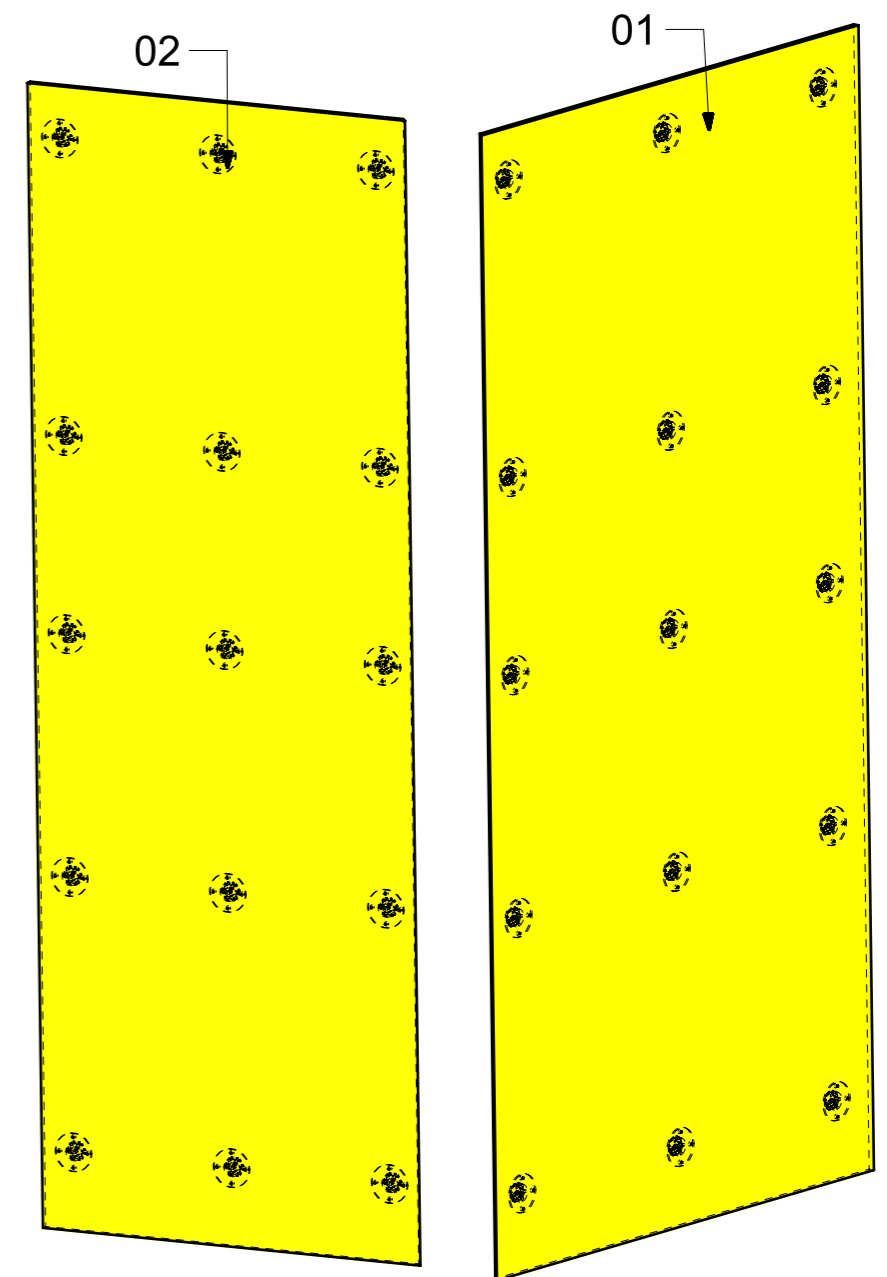
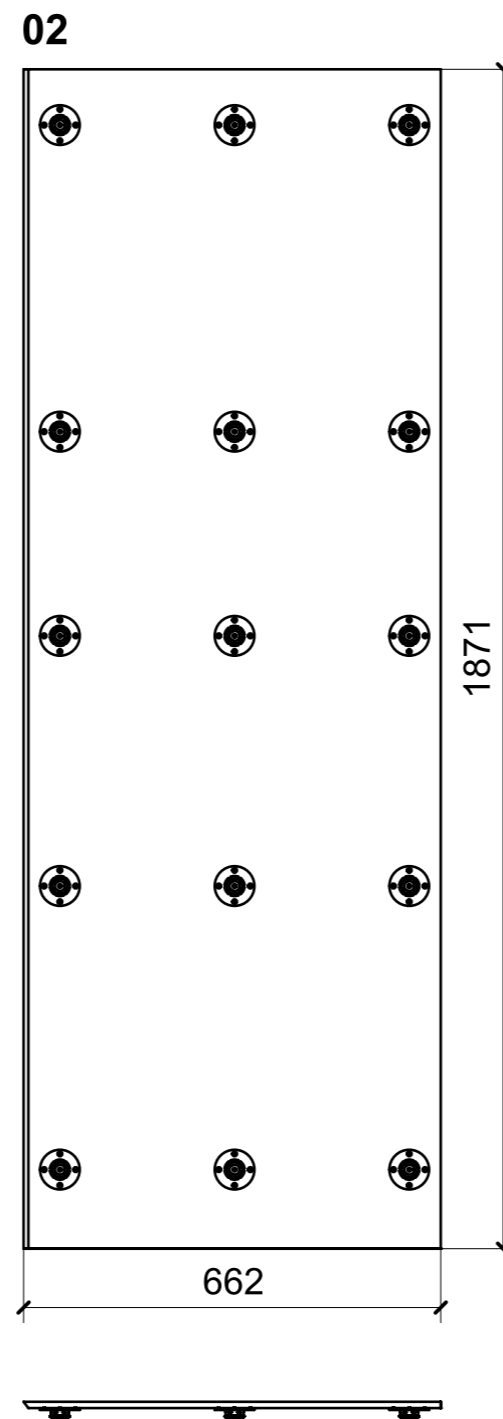
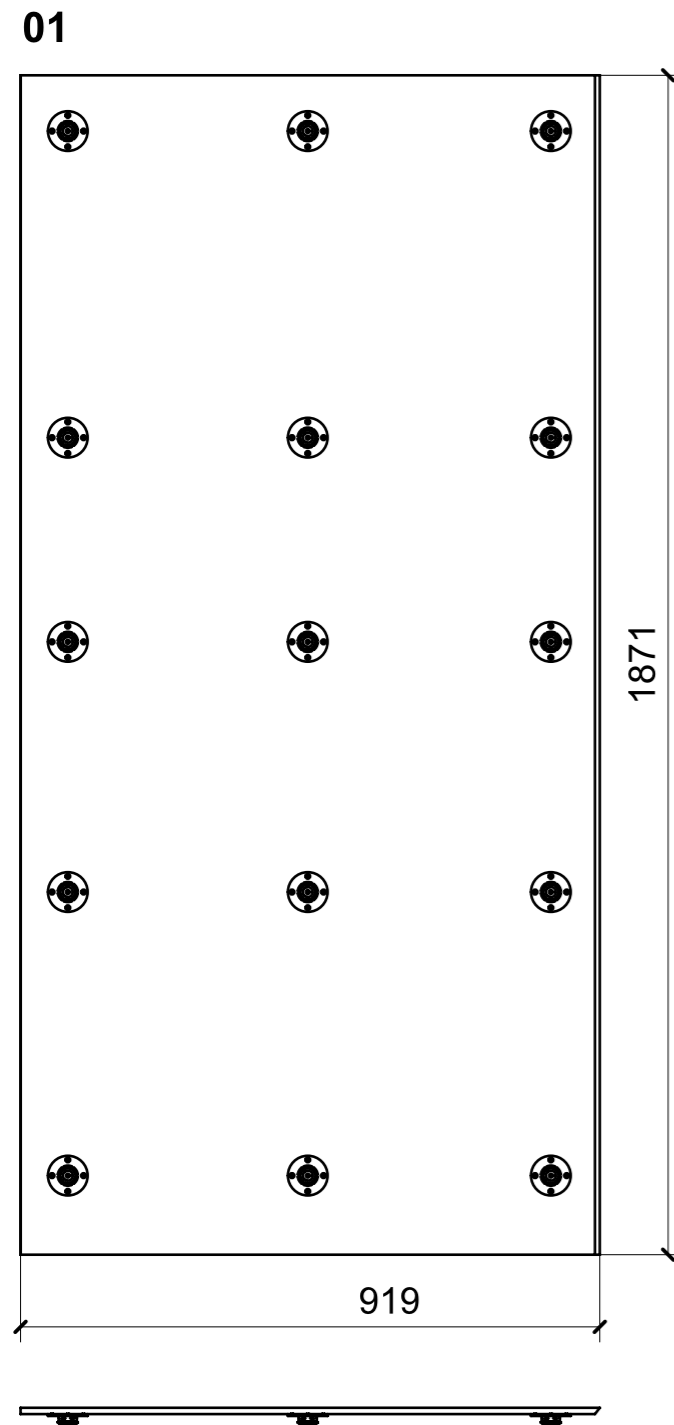

FERRAMENTA	QTY
FITLOCK M_MASCHERPA_3MM_6020202101	30

LOCALE	CODICE	DESCRIZIONE COMPONENTE	FINITURA	Q.TA
CABINA VIP	MD299_I01_VV01	CUSCINO E TESTALETTO	OKUME' GREZZO	1

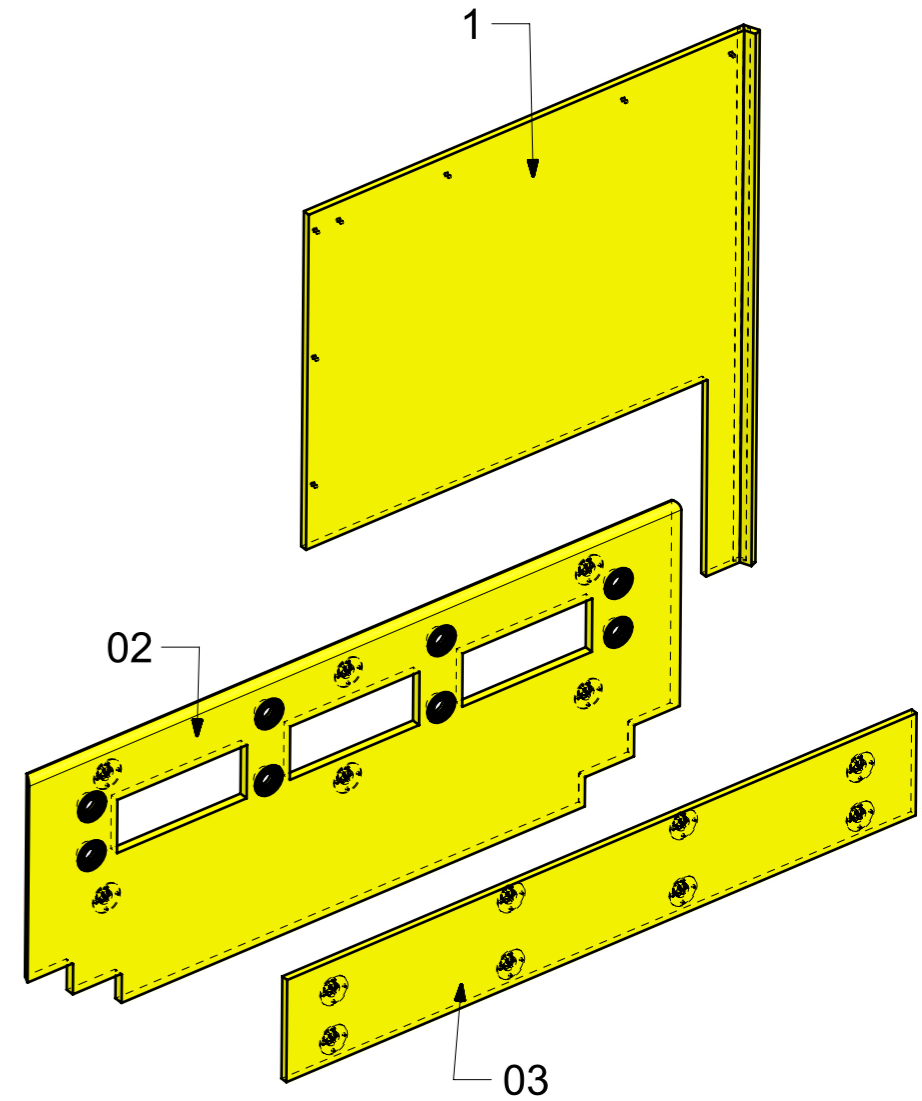
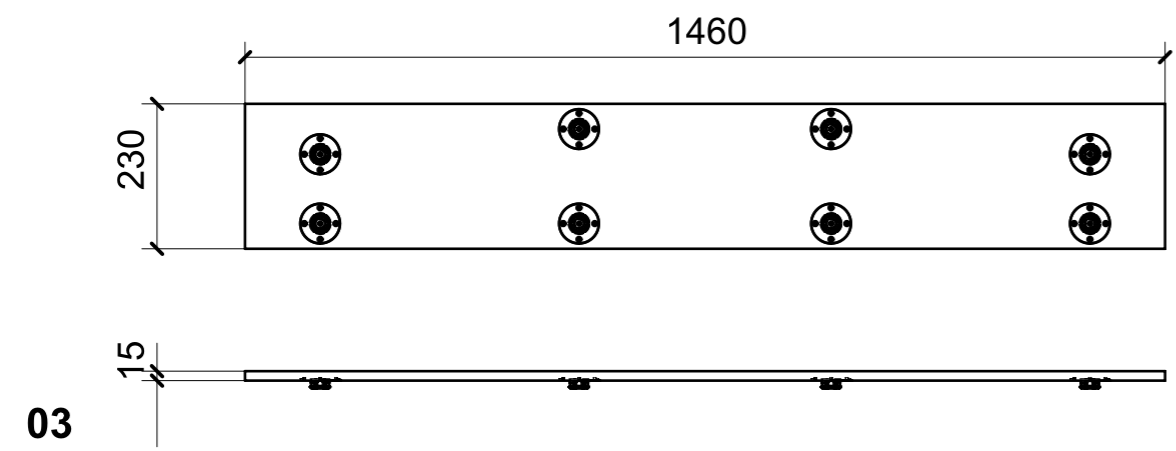
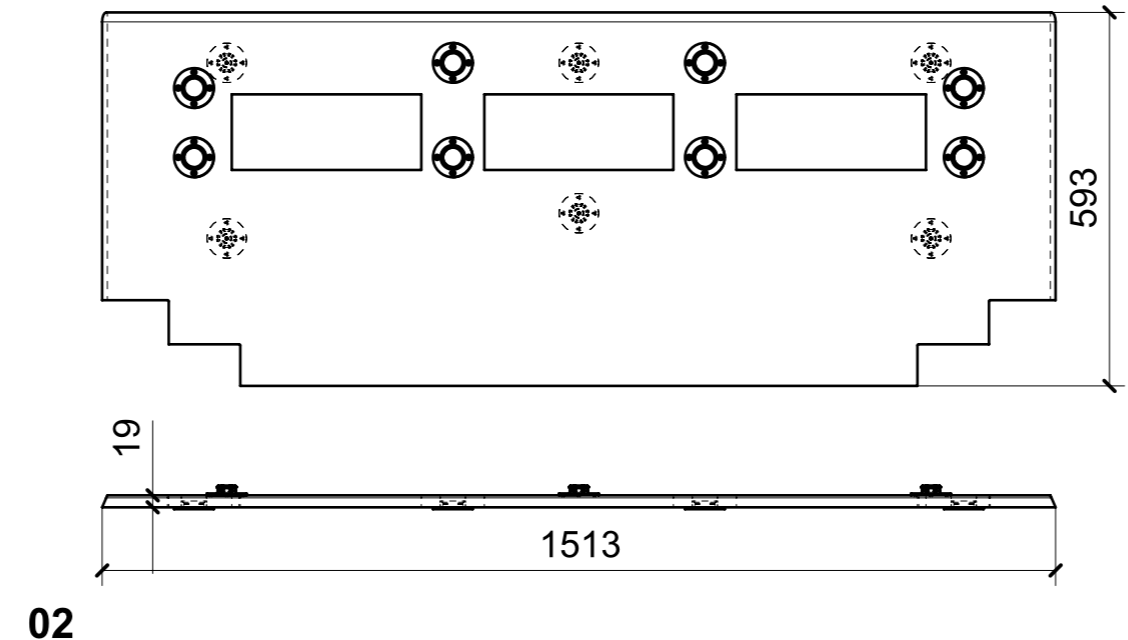
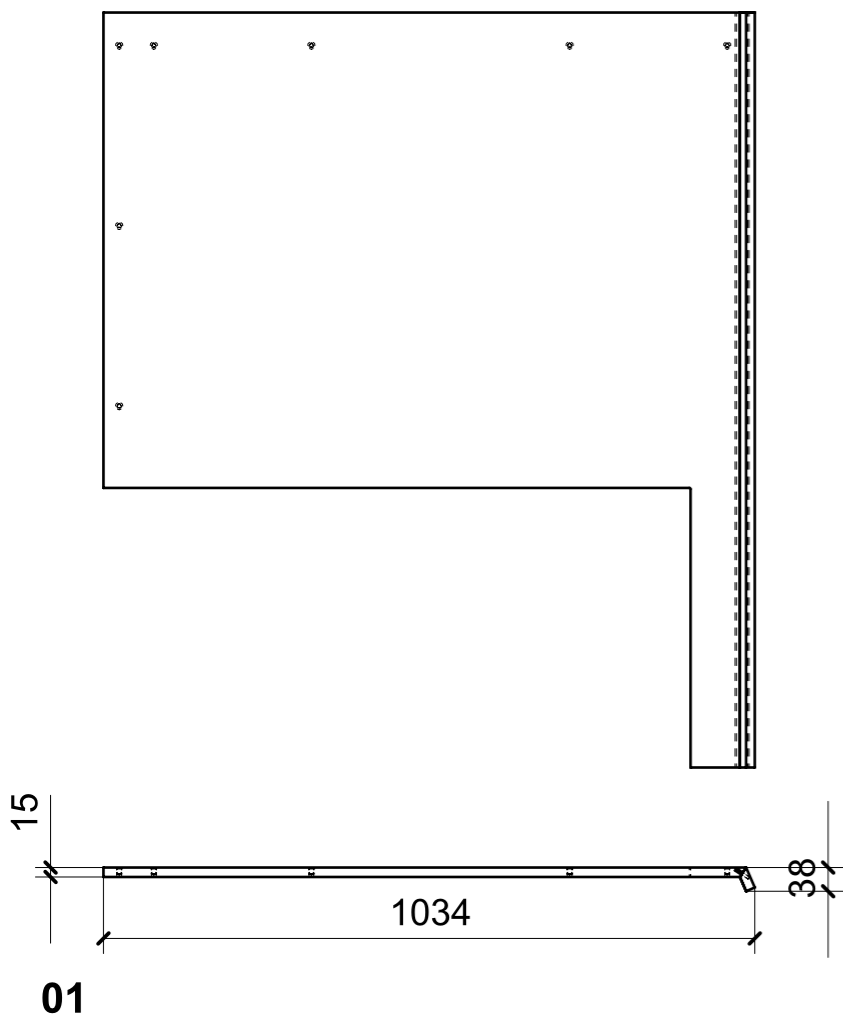

FERRAMENTA	QTY
BUSSOLA 6MA X 10 FORO DIAM.8	7
FITLOCK M_MASCHERPA_3MM_6020202101	14
FITLOCK F_MASCHERPA_6020101102	8

LOCALE	CODICE	DESCRIZIONE COMPONENTE	FINITURA	Q.TA
CABINA VIP	MD299_I01_VY01	CORNICE OBLO DX	OKUME' GREZZO	1

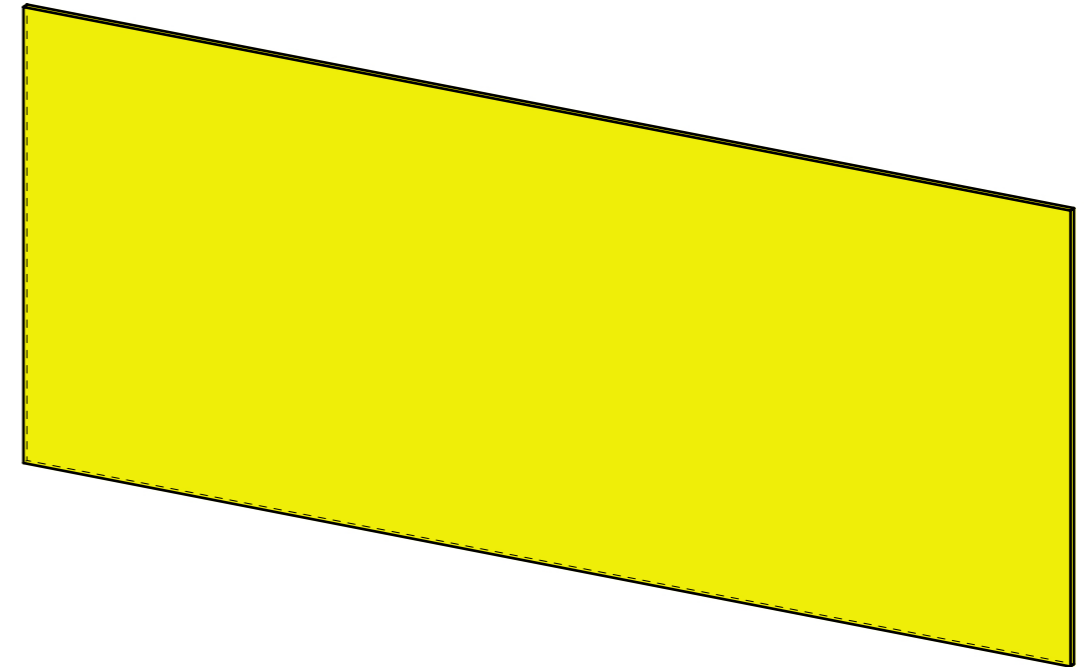
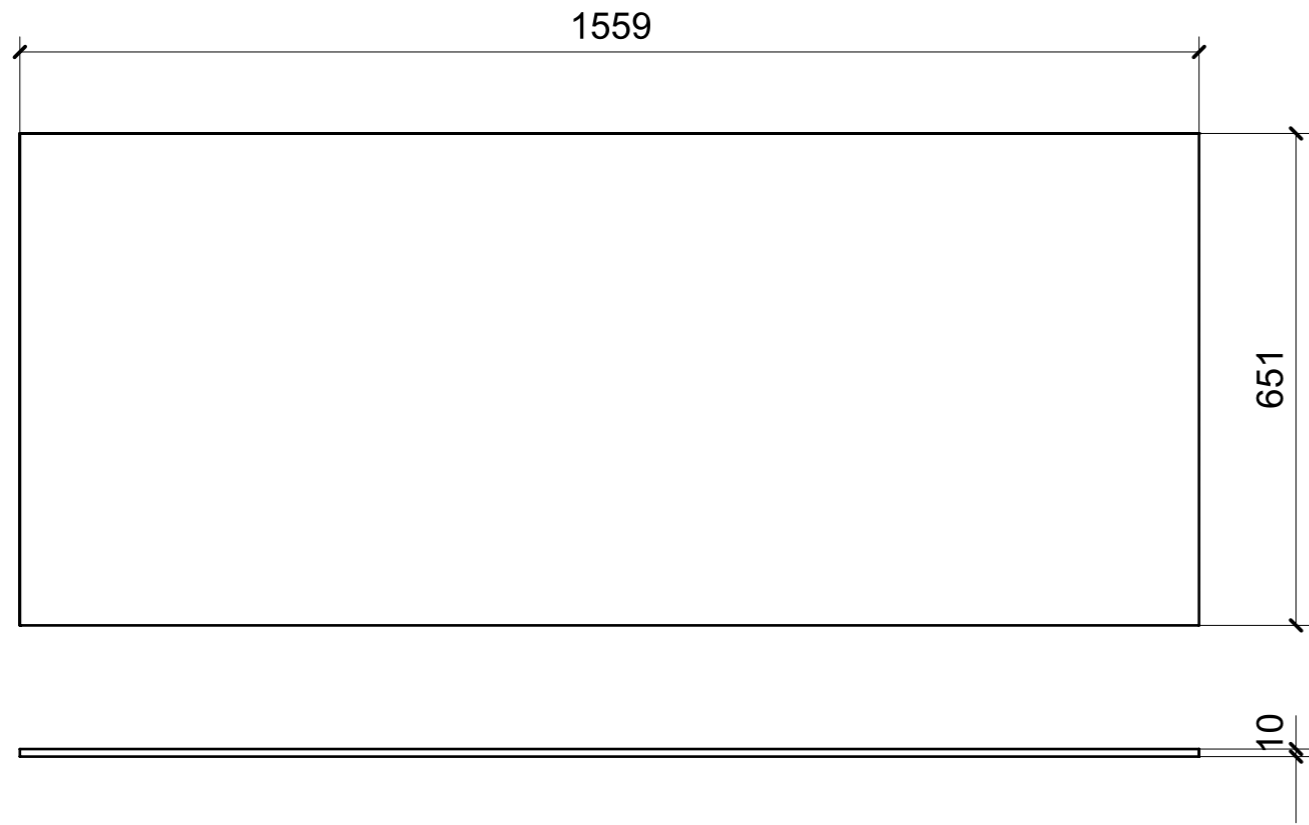

LOCALE	CODICE	DESCRIZIONE COMPONENTE	FINITURA	Q.TA
CABINA VIP	MD299_I01_VZ01	CORNICE OBLO SX	OKUME' GREZZO	1

