

LOCALE	CODICE	DESCRIZIONE COMPONENTE	FINITURA	GR.
CABINA ARMATORE	MD299_I01_AC01	PONTE AC MURATA SX	OKUME' GREZZO	16

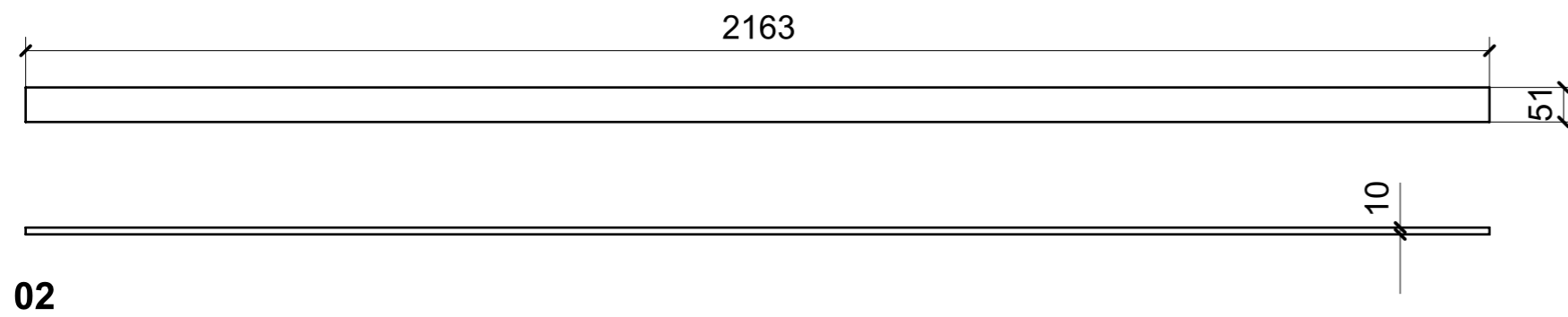

LOCALE	CODICE	DESCRIZIONE COMPONENTE	FINITURA	Q.TA
CABINA ARMATORE	MD299_I01_AE01	RIVESTIMENTO PARETE TV	OKUME' GREZZO	1

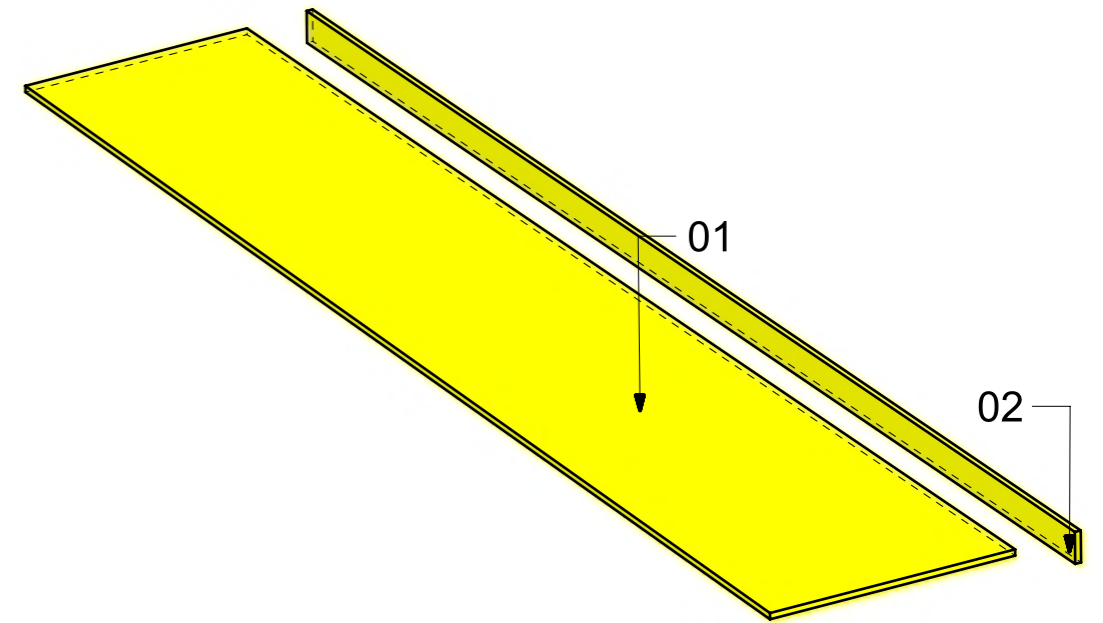
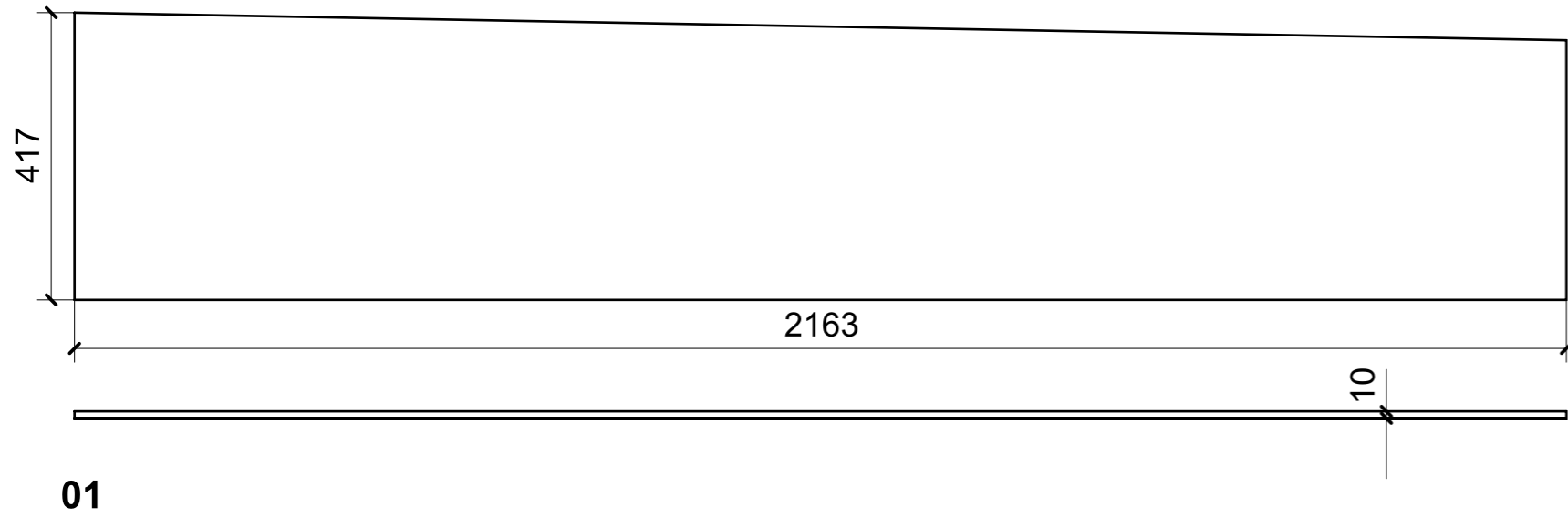
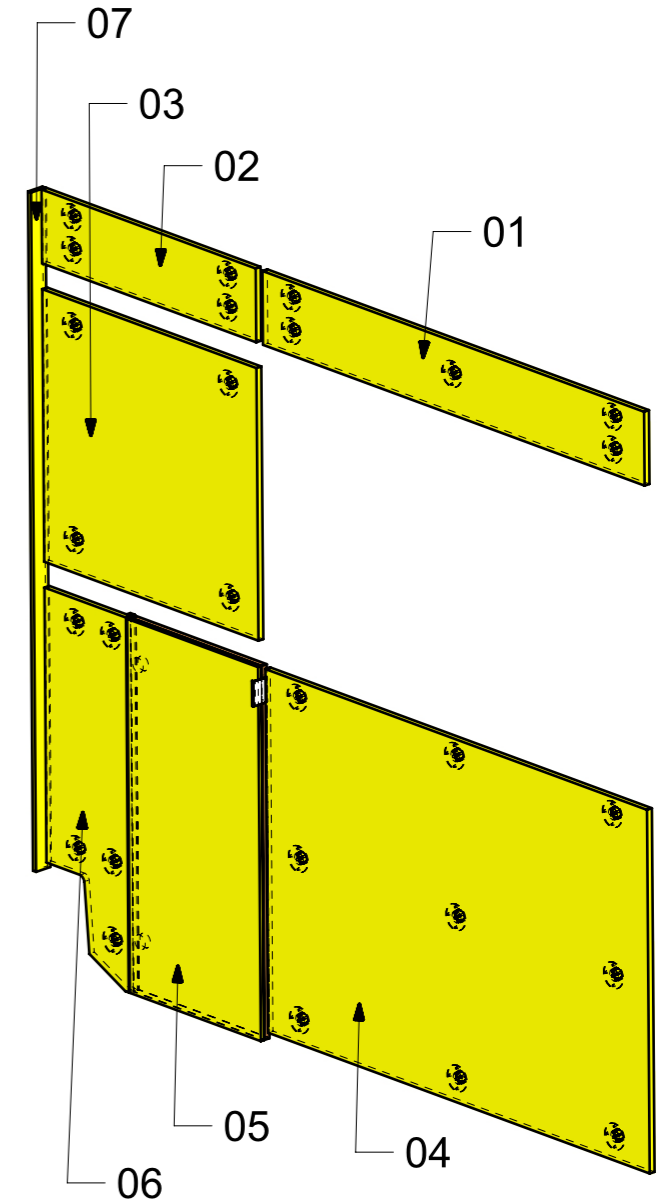
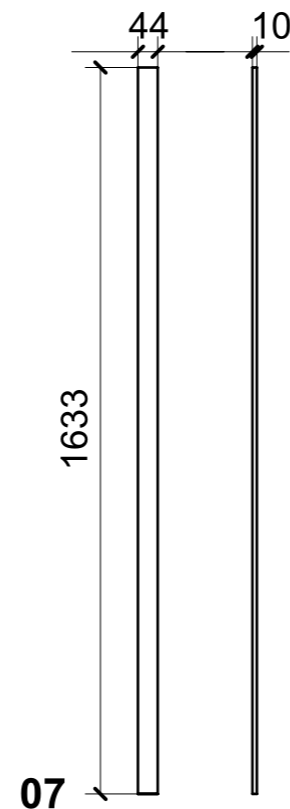
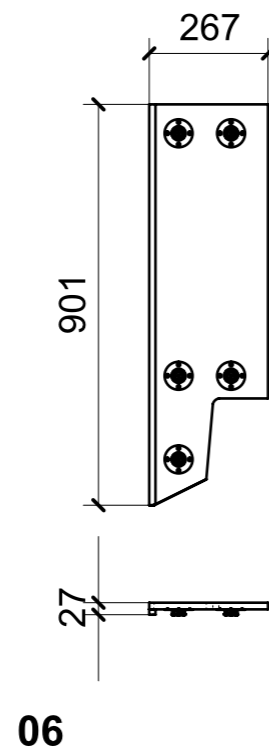
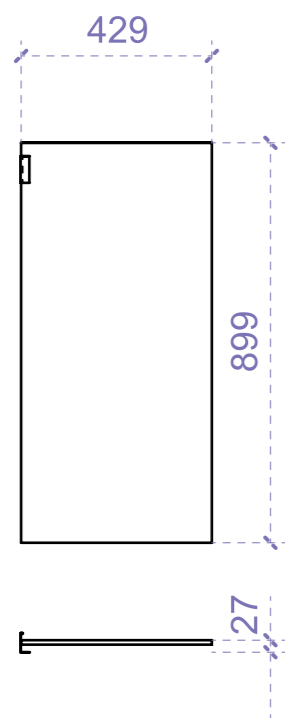
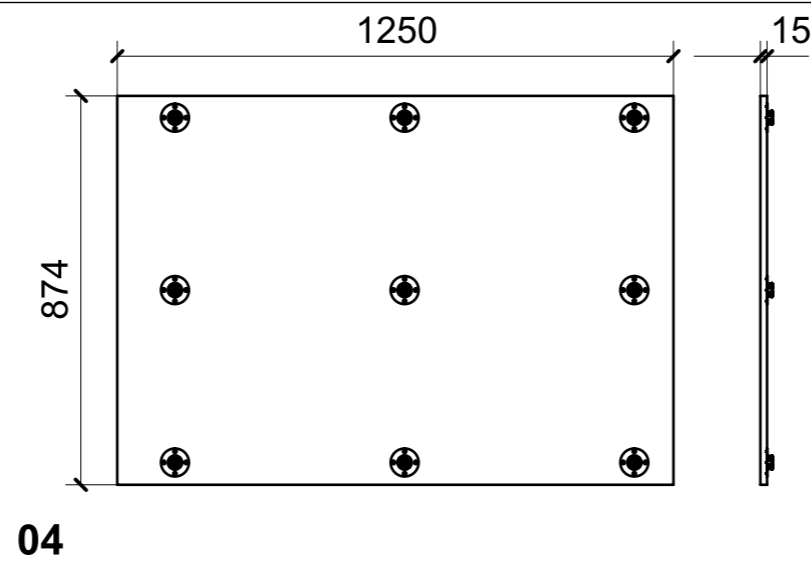
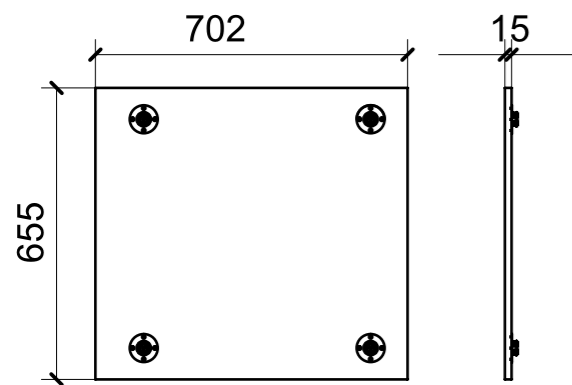
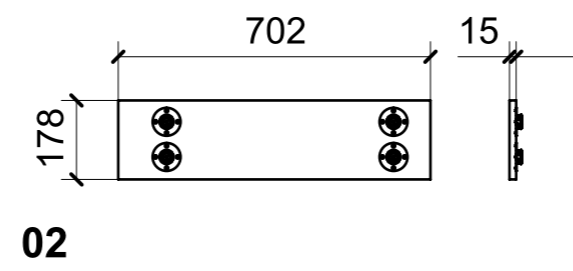
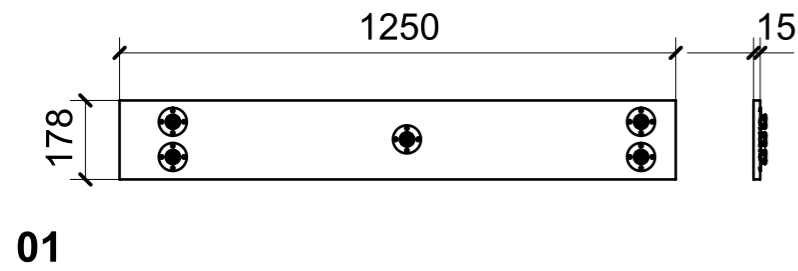

FERRAMENTA	QTY
MANIGLIA ALLUMINIO BIANCA_FBC BORGHI_3620C	1
FITLOCK M_MASCHERPA_3MM_6020202101	27

LOCALE	CODICE	DESCRIZIONE COMPONENTE	FINITURA	Q.TA
CABINA ARMATORE	MD299_I01_AF01	STRUTTURA RIV. BAGNO OSPITI DX	OKUME' GREZZO	1

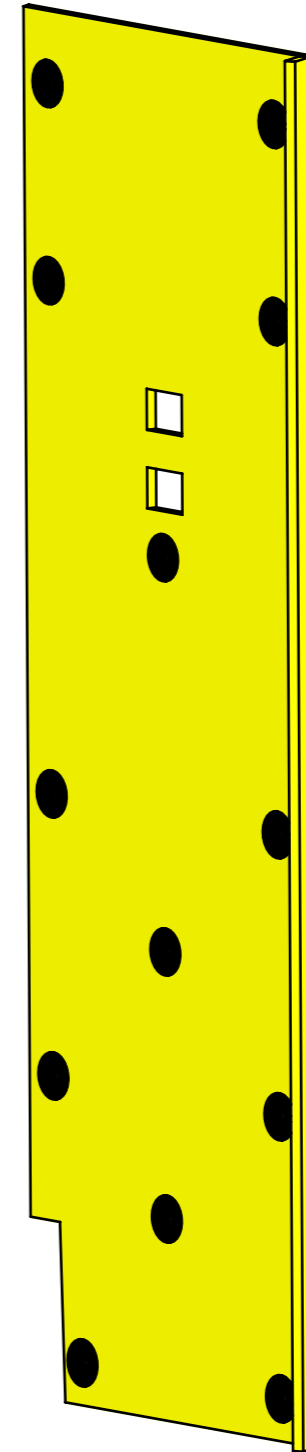
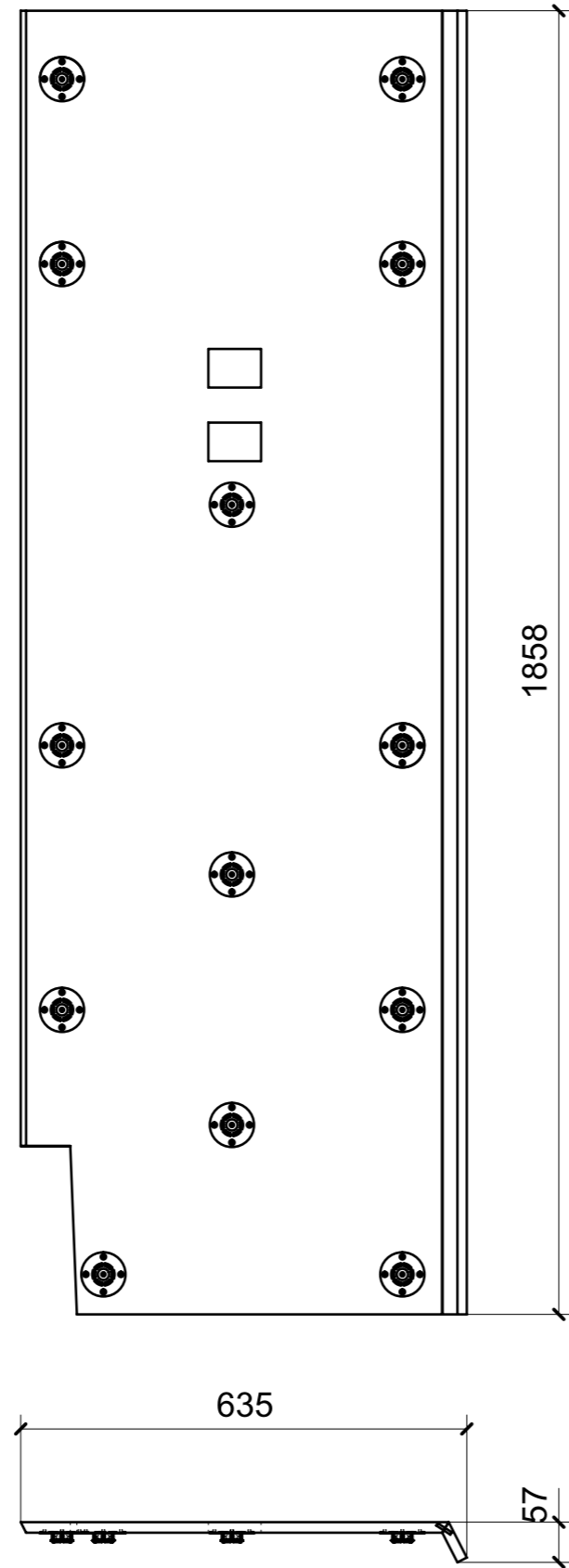

FERRAMENTA	QTY
FITLOCK M_MASCHERPA_3MM_6020202101	13

LOCALE	CODICE	DESCRIZIONE COMPONENTE	FINITURA	Q.TA
CABINA ARMATORE	MD299_I01_AI01	PONTE AC MURATA DX	OKUME' GREZZO	1

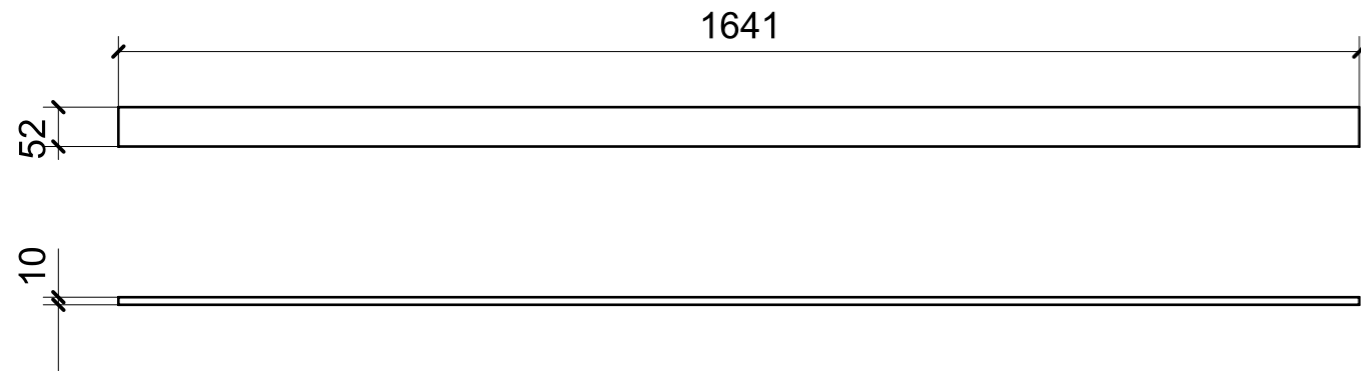

01

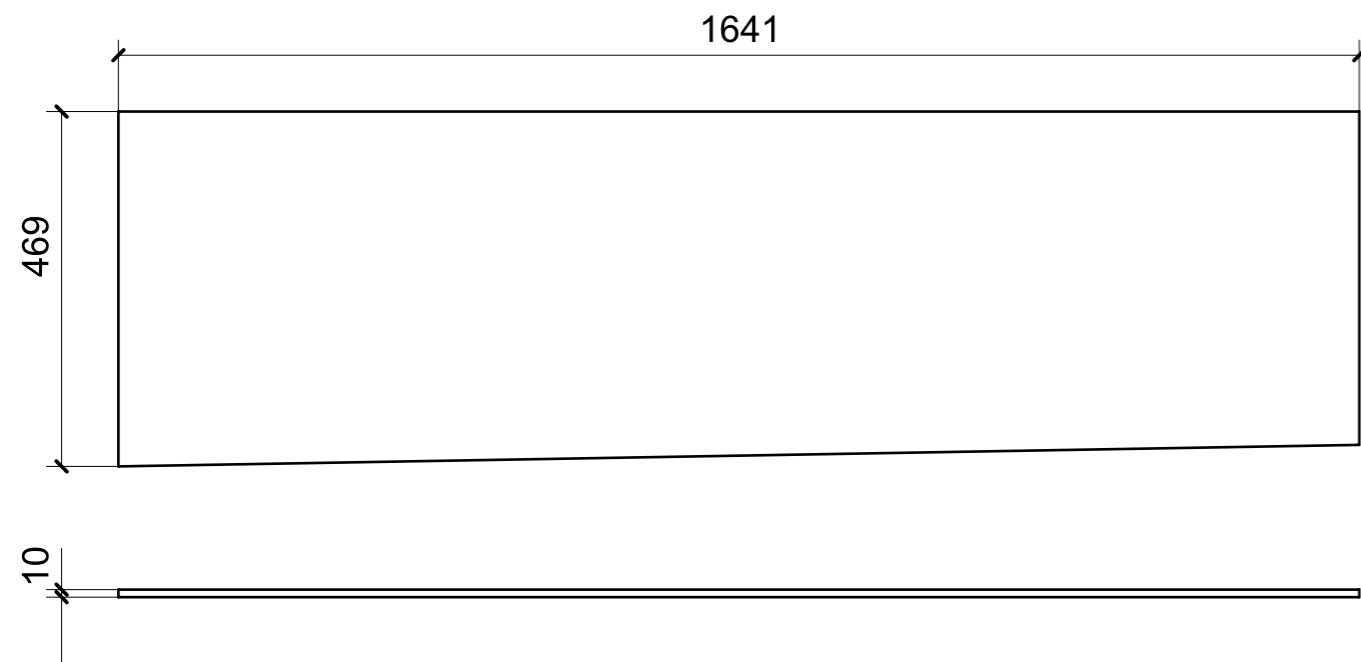
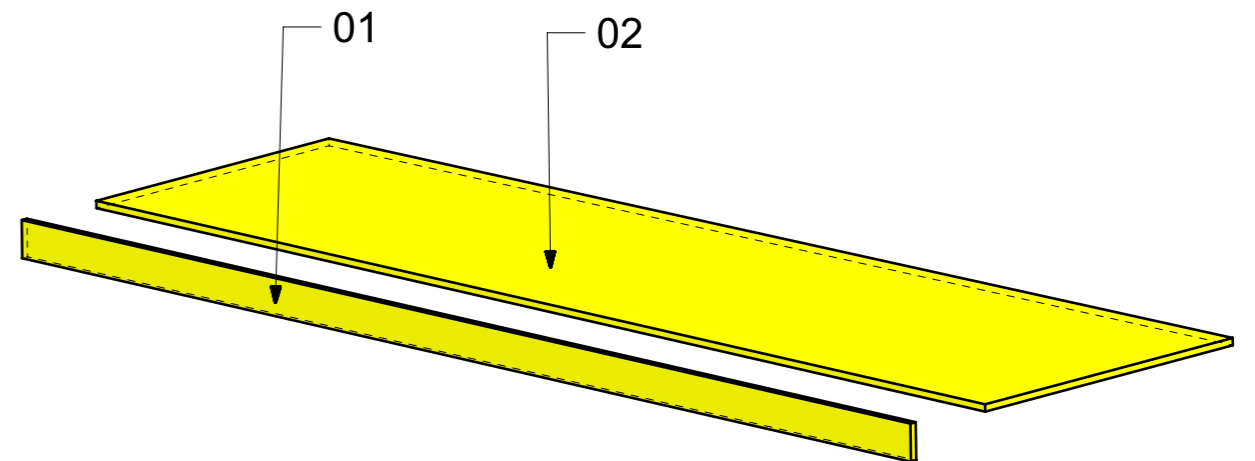

02

LOCALE	CODICE	DESCRIZIONE COMPONENTE	FINITURA	GR.
CABINA ARMATORE	MD320_I01_AJ01	RIV. COLONNA SX VAR 1	OKUME' GREZZO	9

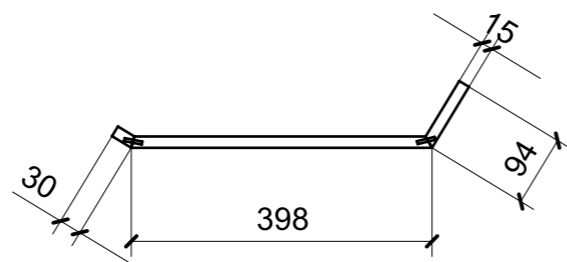
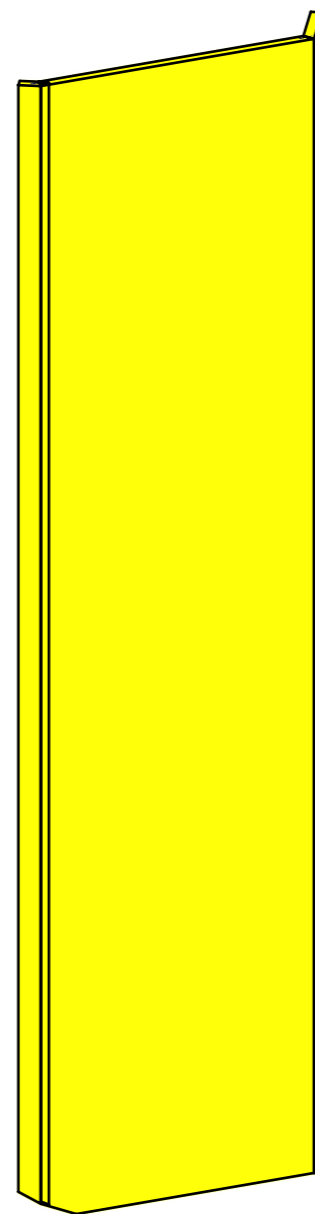
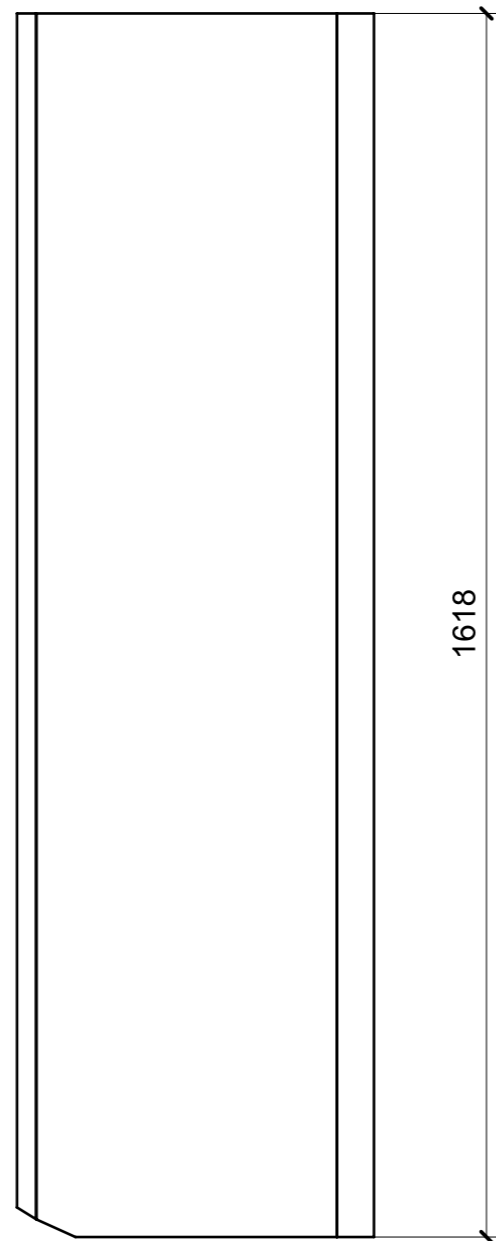

LOCALE	CODICE	DESCRIZIONE COMPONENTE	FINITURA	Q.TA
CABINA ARMATORE	MD299_I01_AM01	CORNICE OBLO SX	OKUME' GREZZO	1

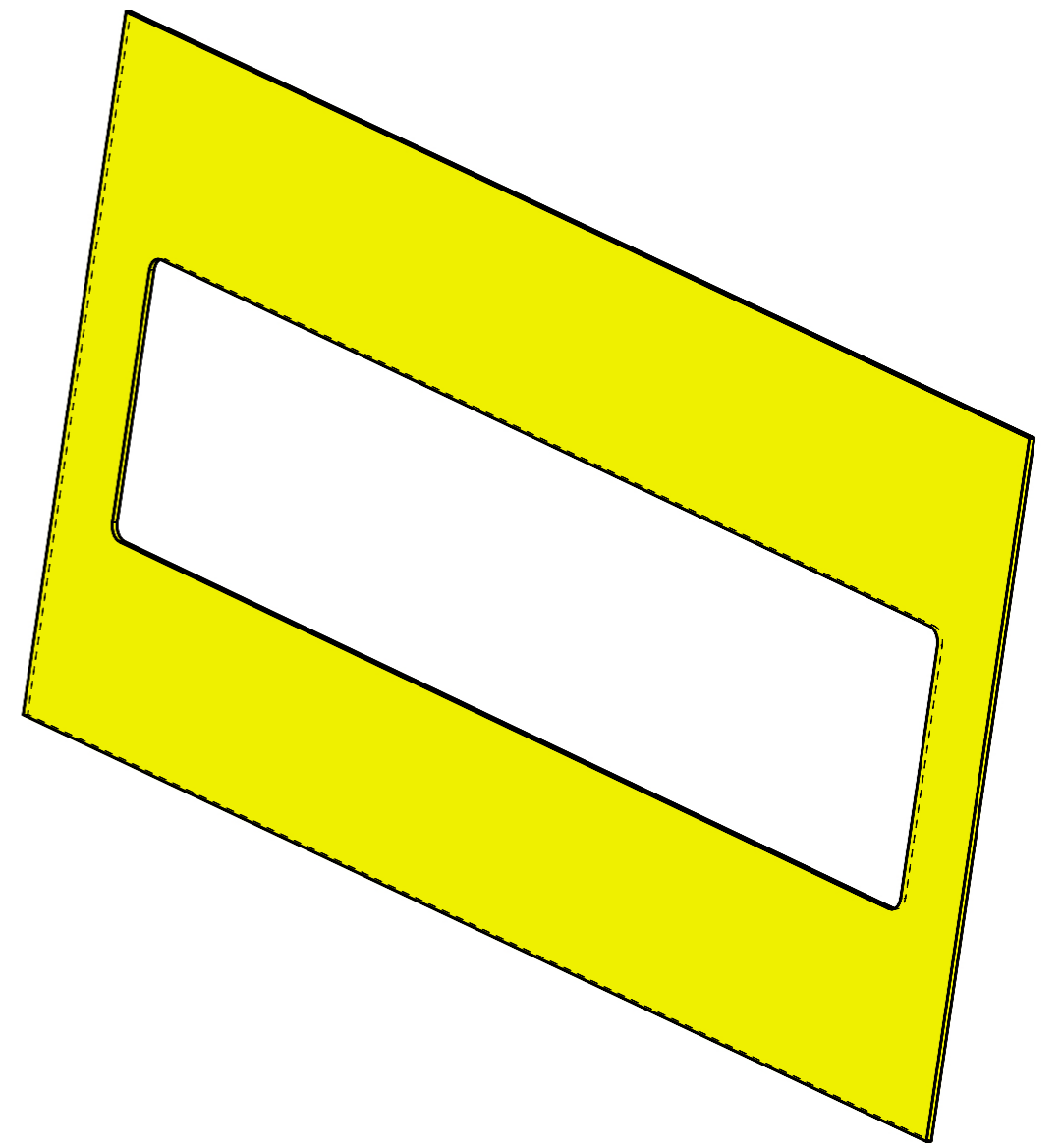
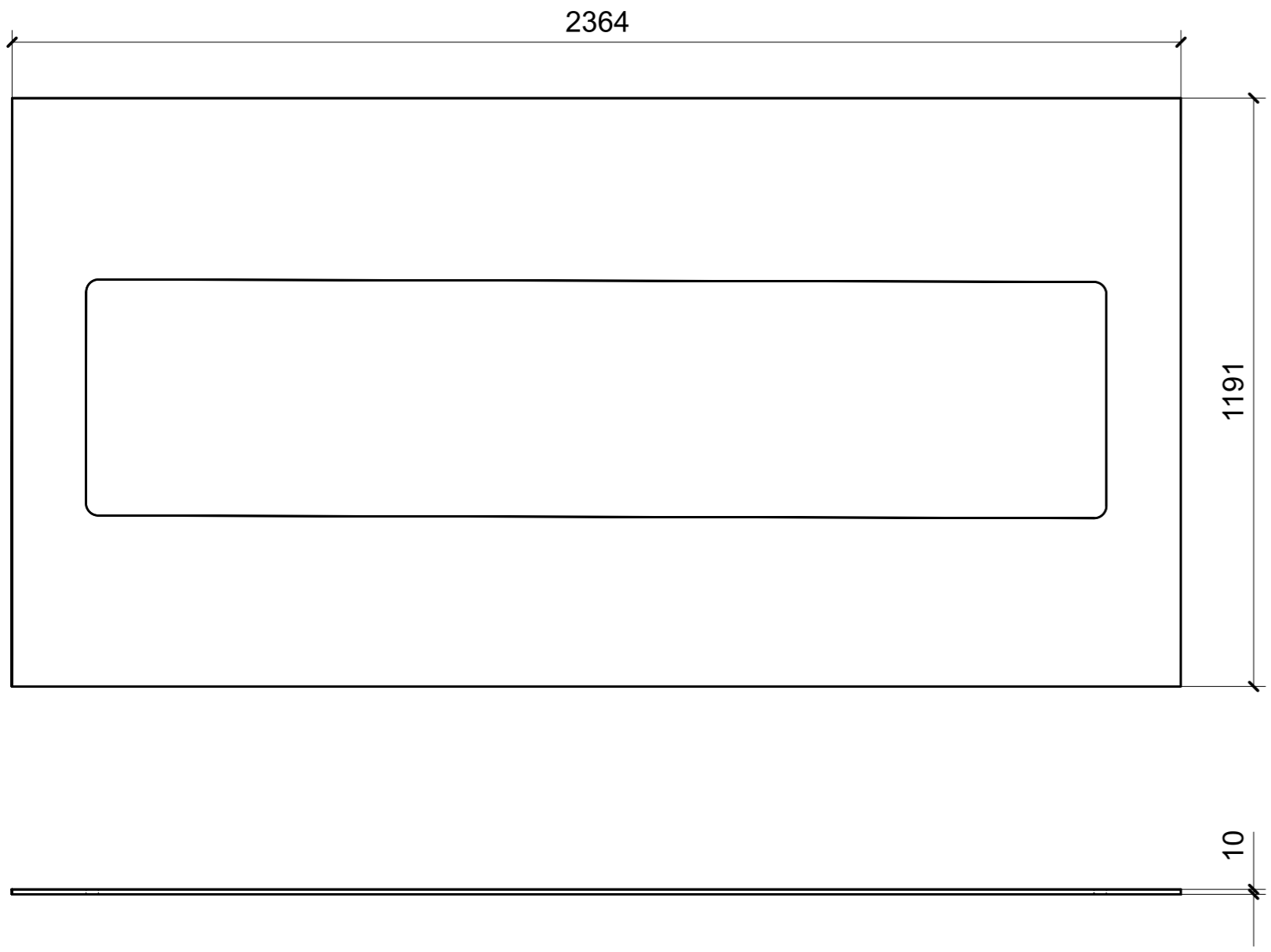

LOCALE	CODICE	DESCRIZIONE COMPONENTE	FINITURA	Q.TA
CABINA ARMATORE	MD299_I01_AN01	CORNICE OBLO DX	OKUME' GREZZO	1

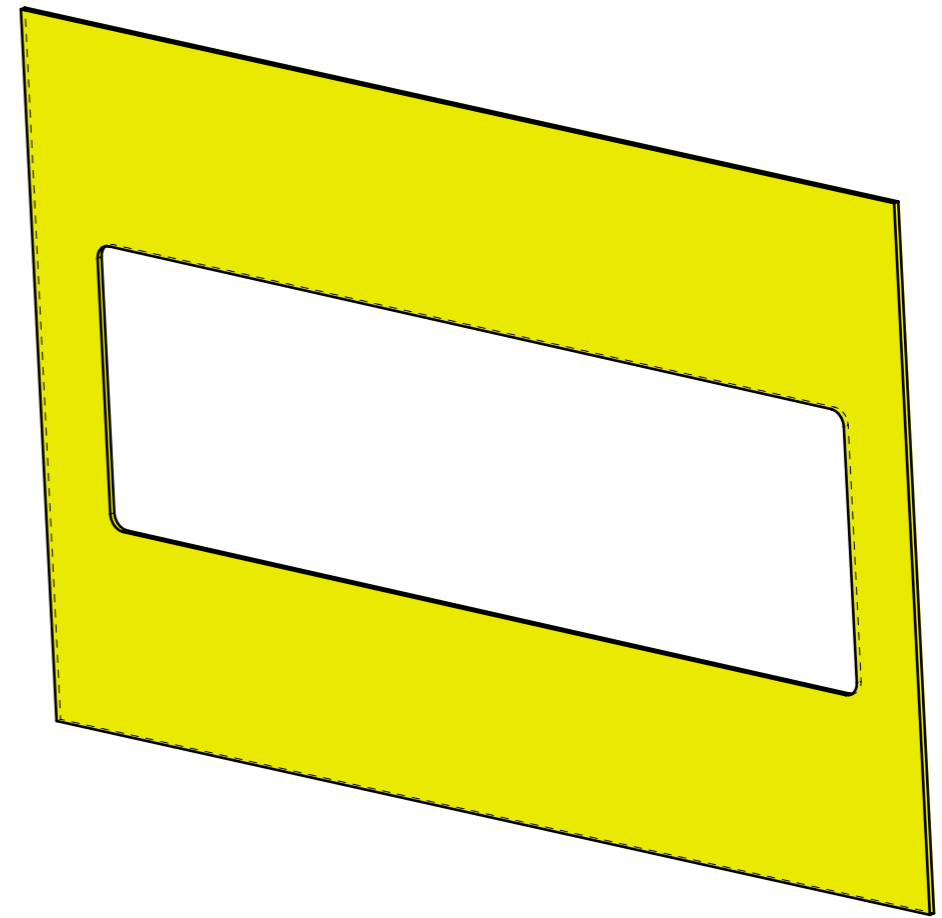
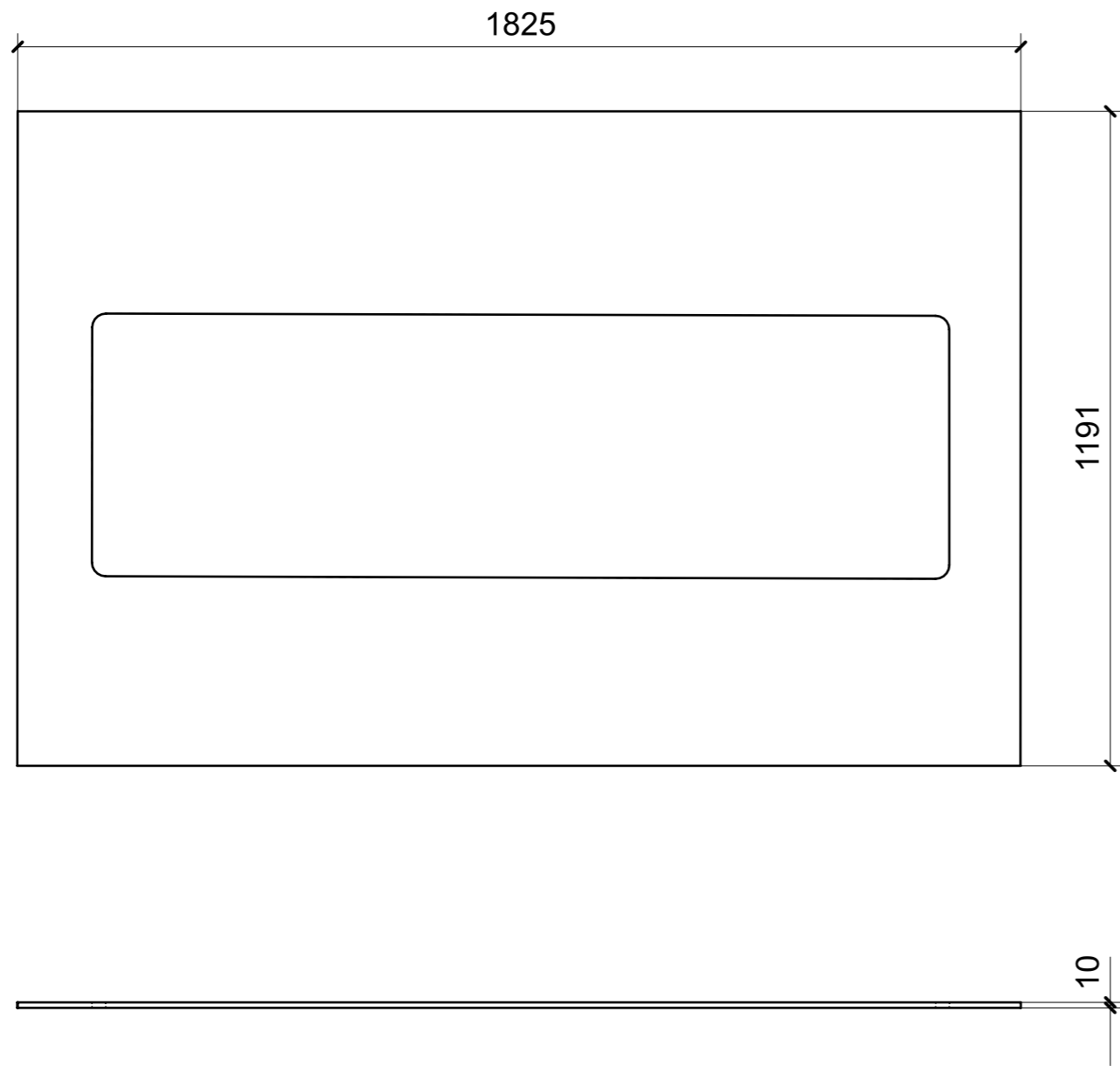

LOCALE	CODICE	DESCRIZIONE COMPONENTE	FINITURA	GR.
CABINA ARMATORE	MD299_I01_A001	STRUTTURA TESTALETTO	OKUME' GREZZO	16

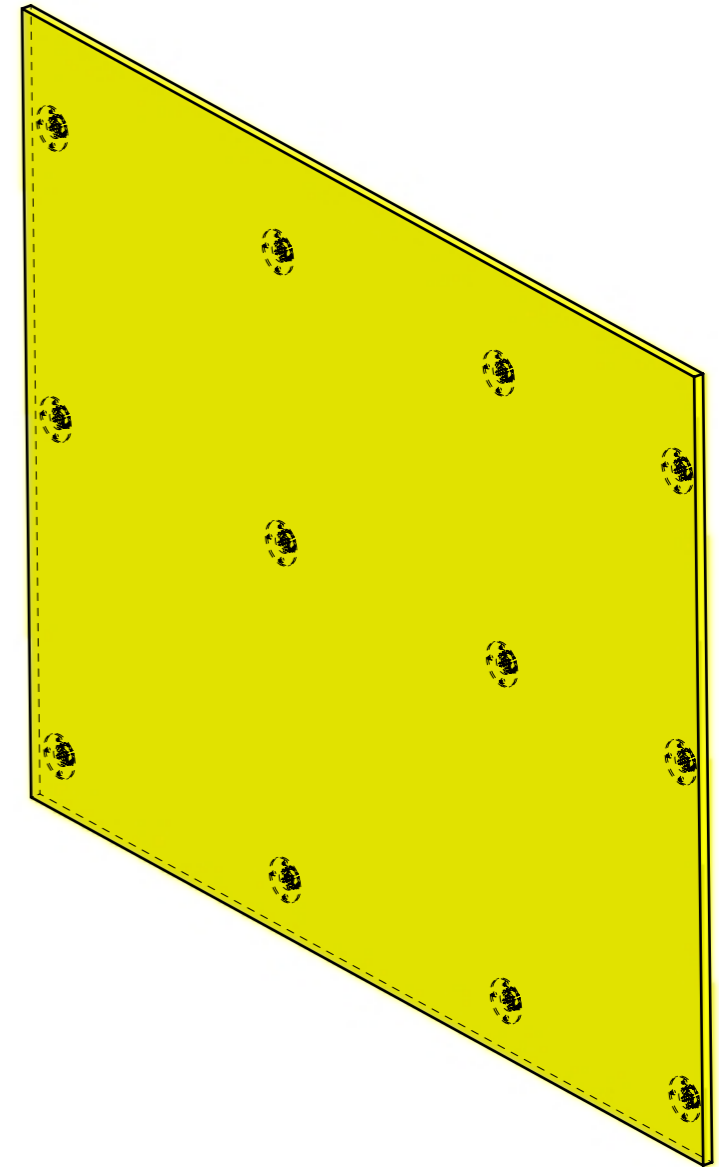
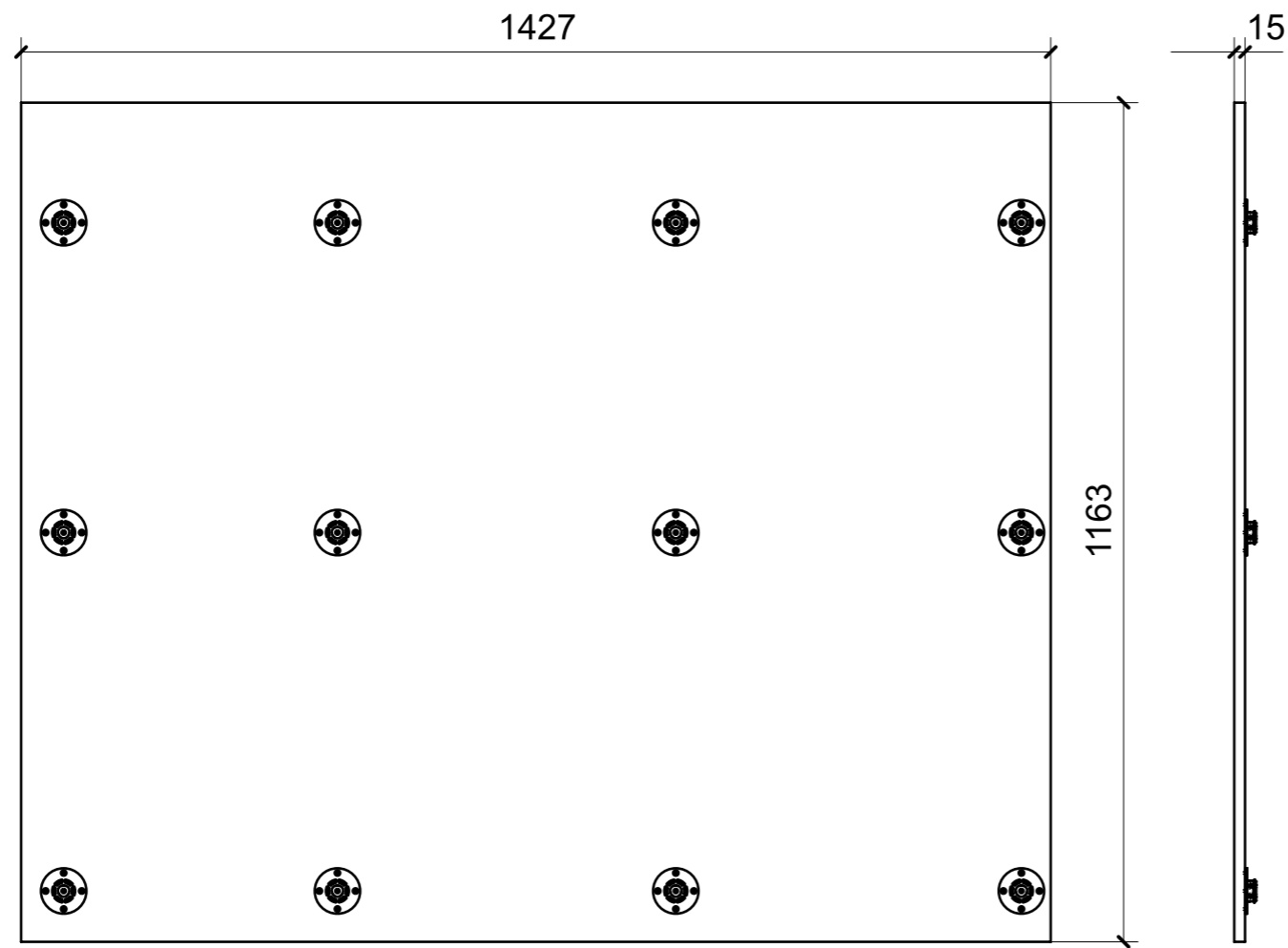

FERRAMENTA	QTY
FITLOCK M_MASCHERPA_3MM_6020202101	12

LOCALE	CODICE	DESCRIZIONE COMPONENTE	FINITURA	GR
CABINA ARMATORE	MD299_I01_AP01	LETTO_STD VAR.1	OKUME' GREZZO	12

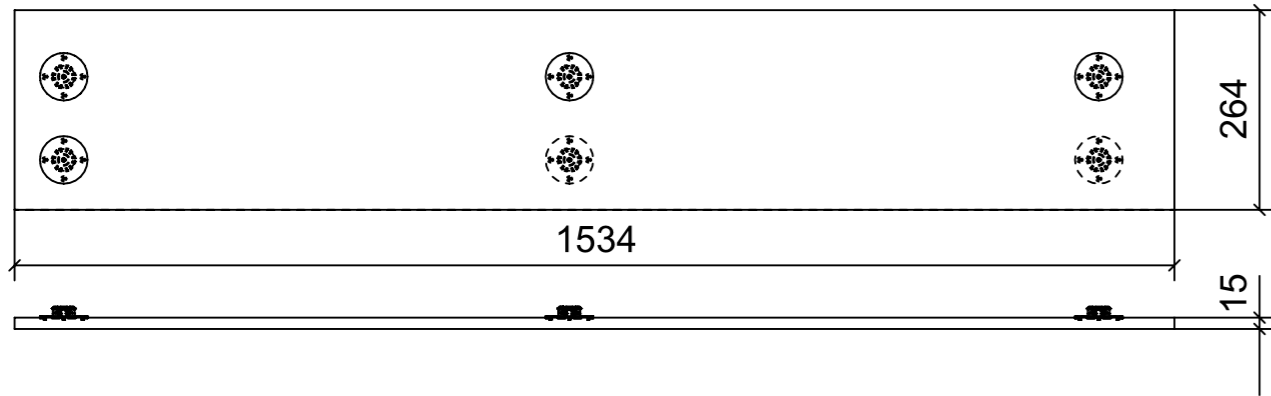

01

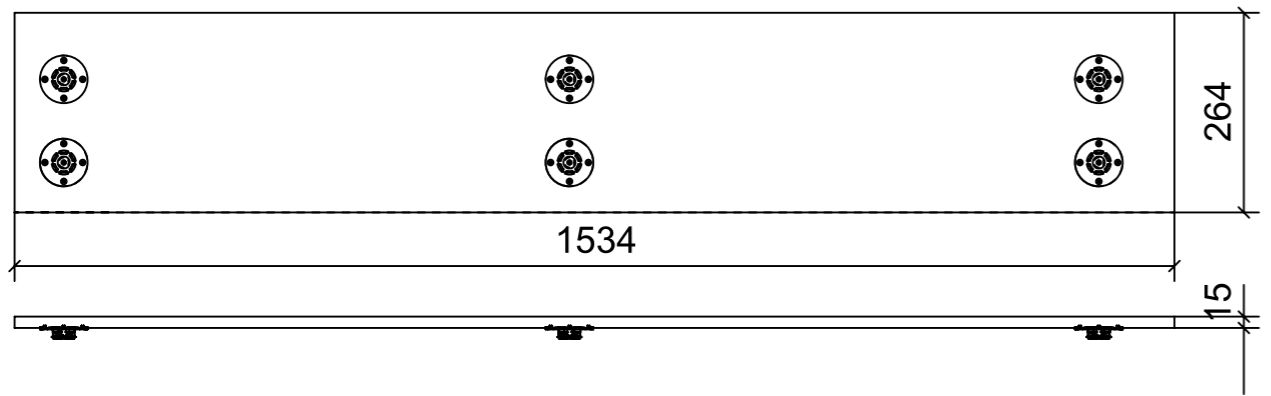

02

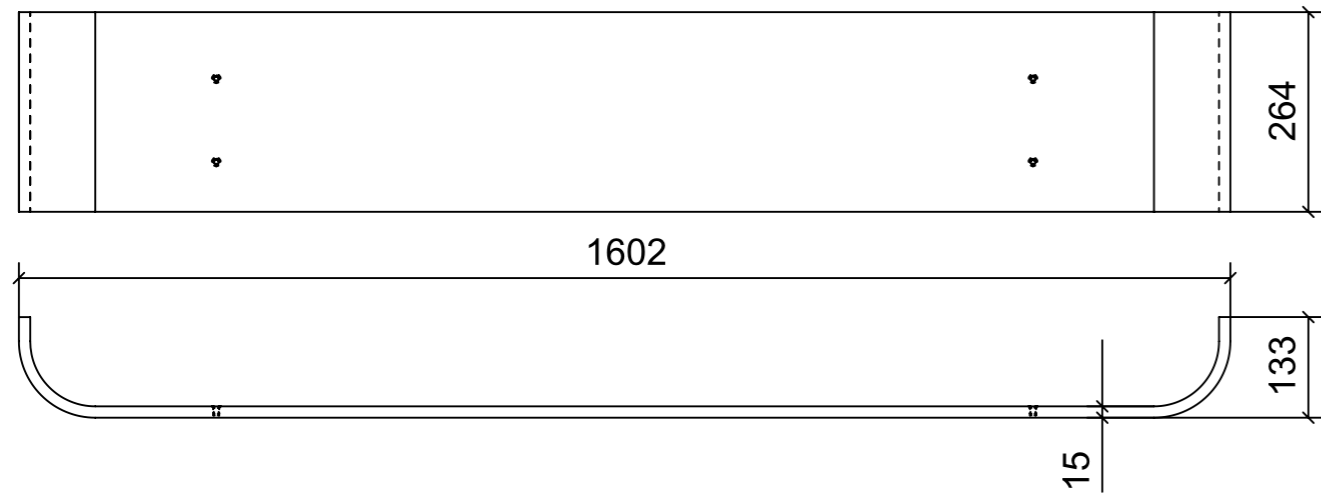

03

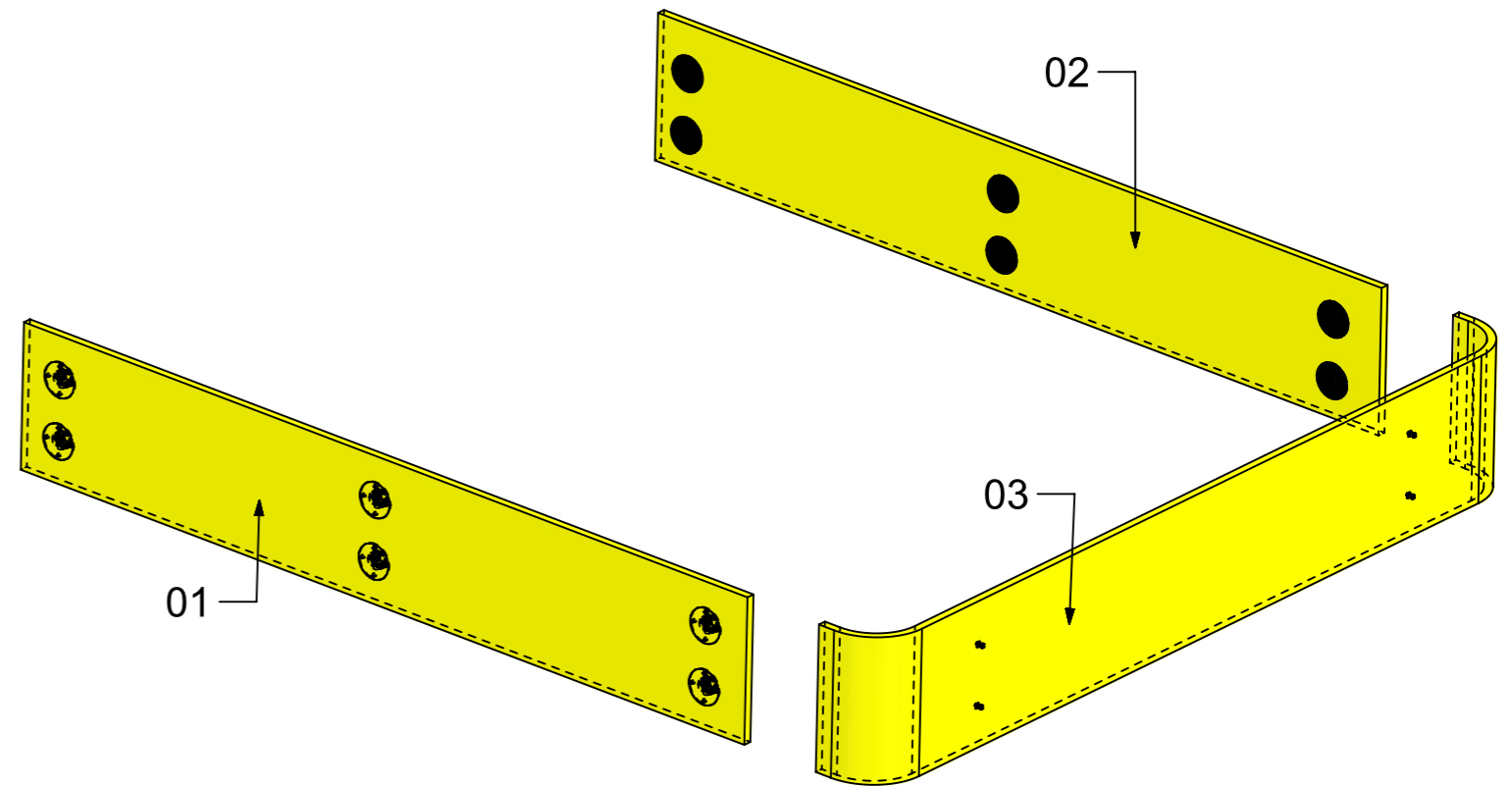

FERRAMENTA	QTY
BUSSOLA 6MA X 10 FORO DIAM.8	4
FITLOCK M_MASCHERPA_3MM_6020202101	12

LOCALE	CODICE	DESCRIZIONE COMPONENTE	FINITURA	GR.
CABINA ARMATORE	MD299_I01_AQ01	COMODINO SX_STD VAR 1	OKUME' GREZZO	16

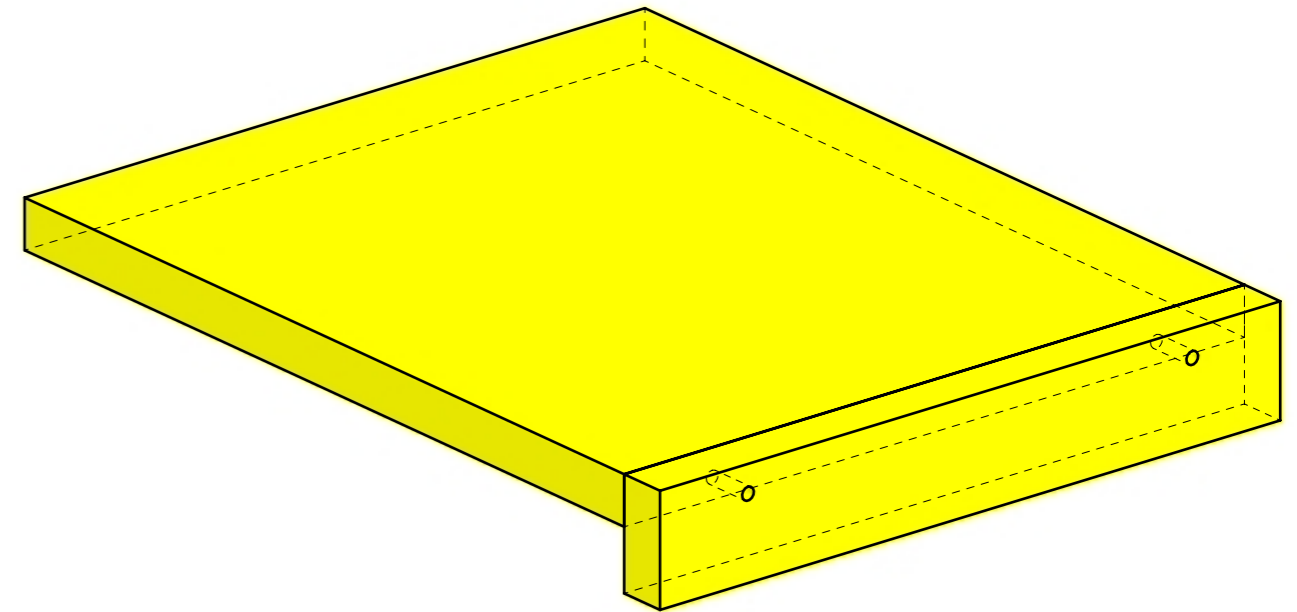
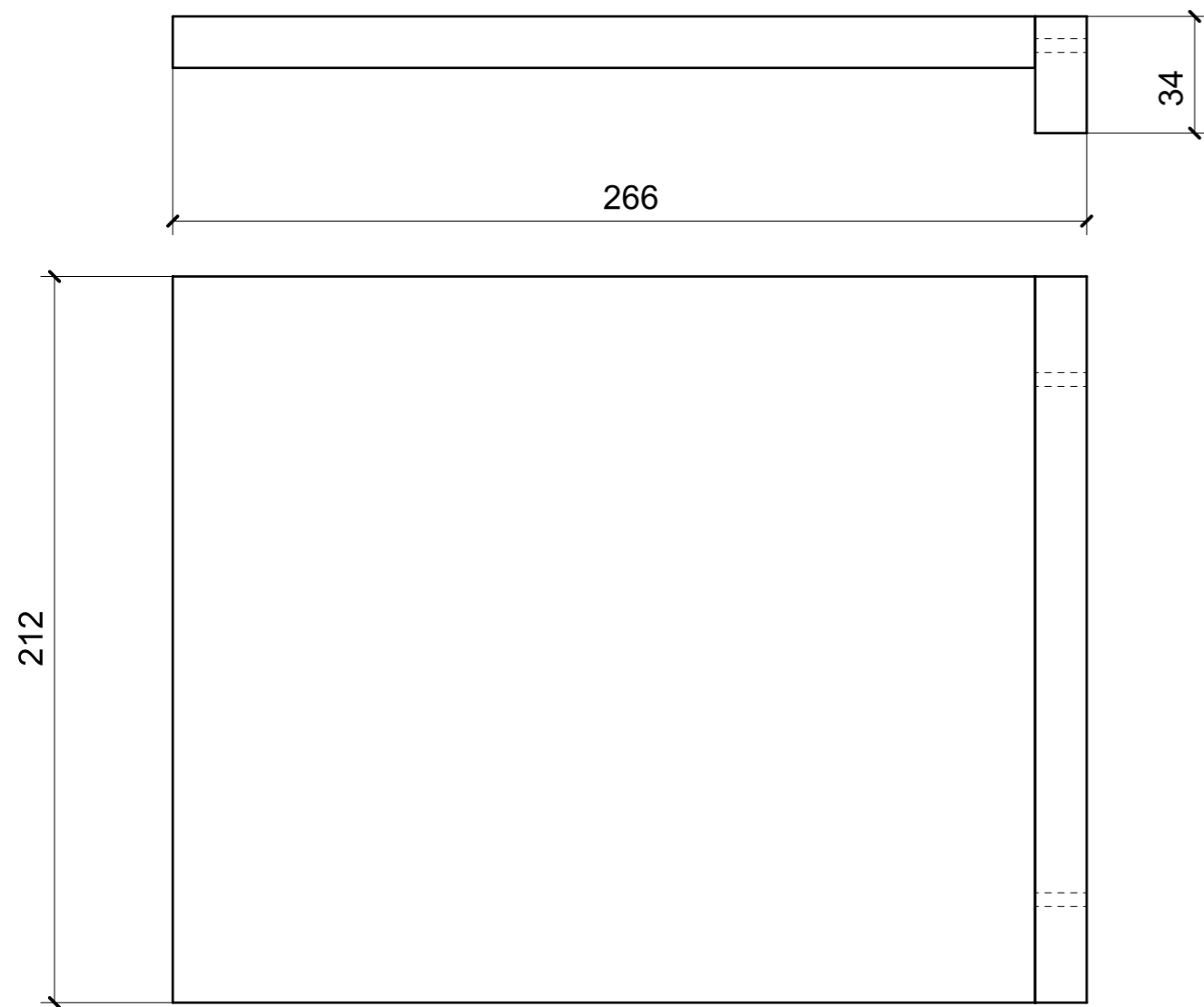

LOCALE	CODICE	DESCRIZIONE COMPONENTE	FINITURA	GR.
CABINA ARMATORE	MD299_I01_AR01	COMODINO DX_STD VAR 1	OKUME' GREZZO	16

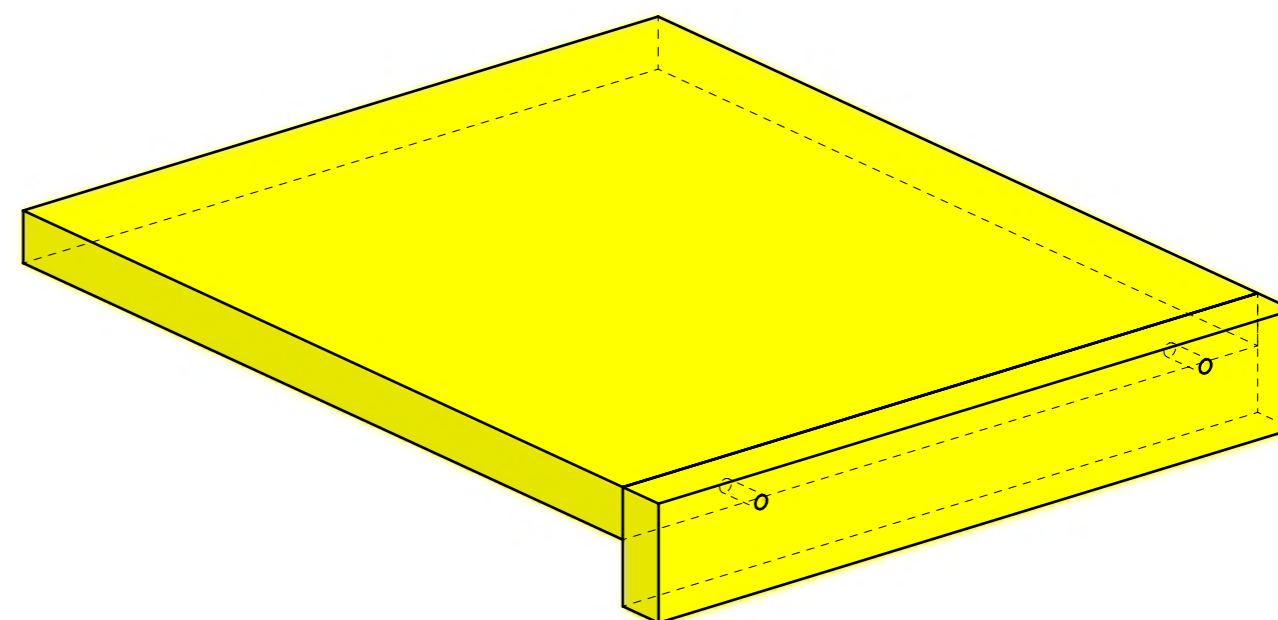
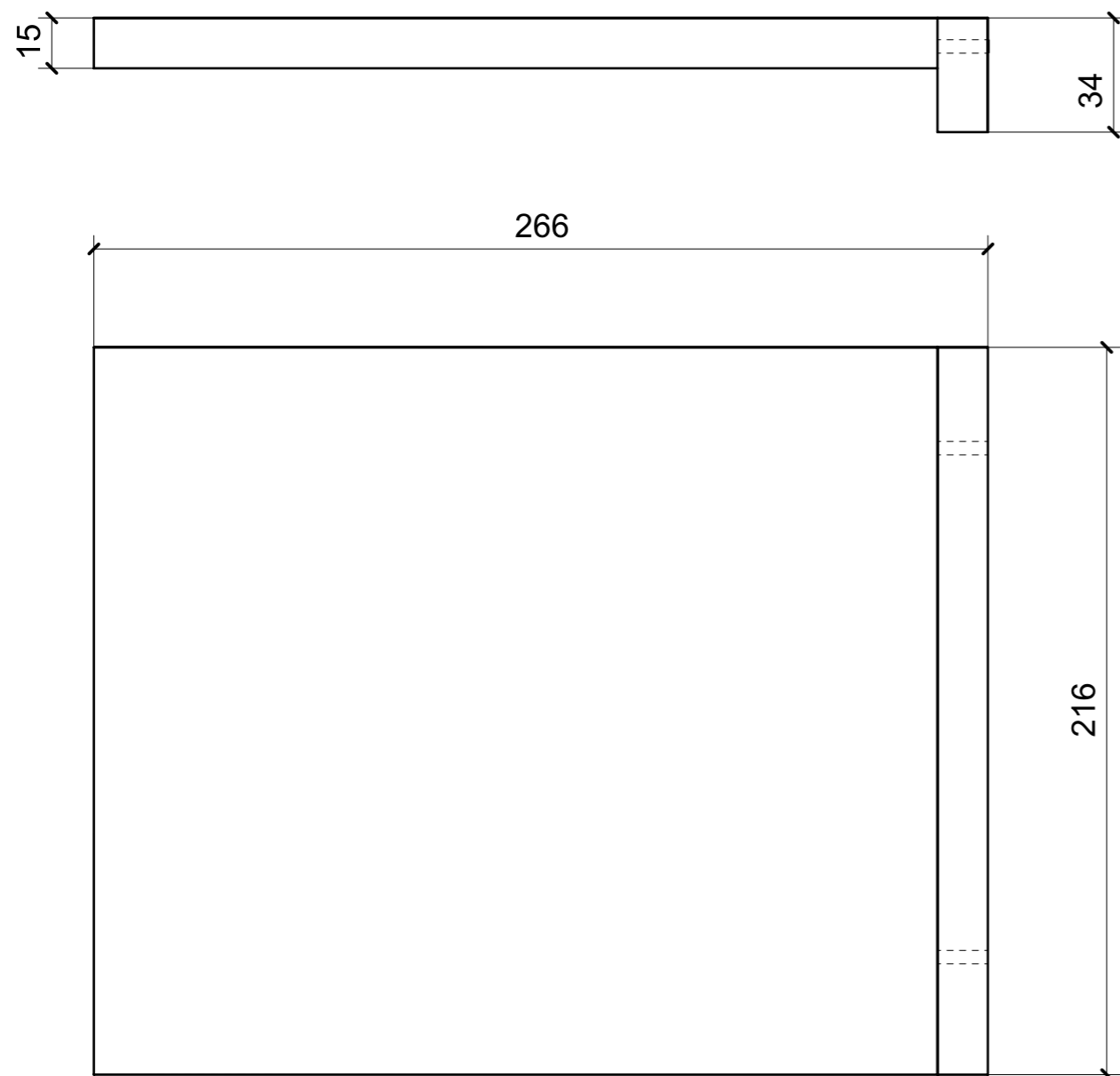

LOCALE	CODICE	DESCRIZIONE COMPONENTE	FINITURA	Q.TA
CABINA ARMATORE	MD299_I01_AS01	CIELINO	OKUME' GREZZO	1

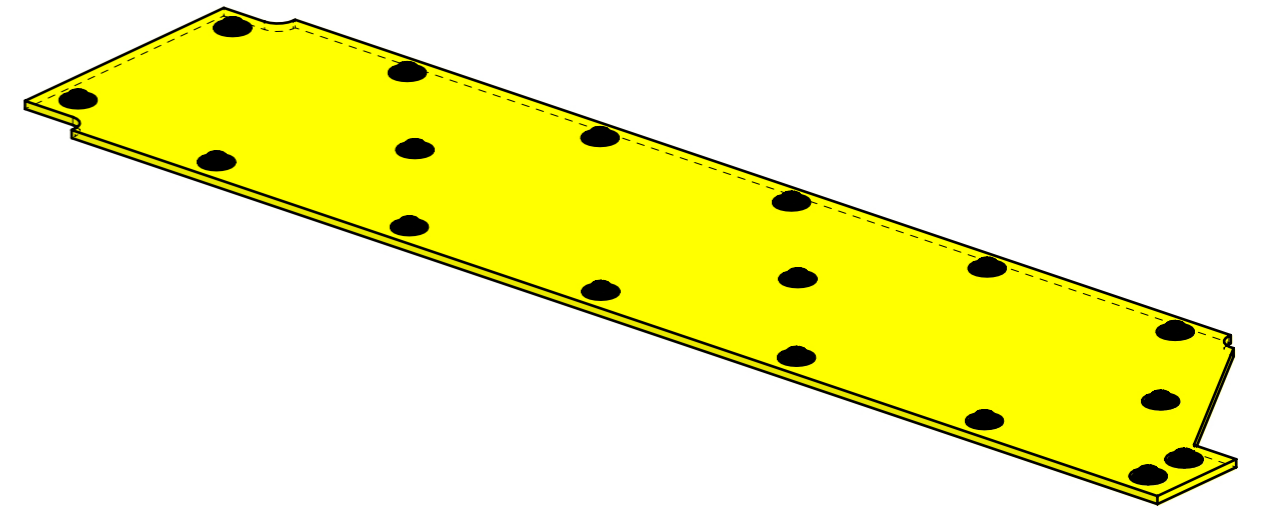
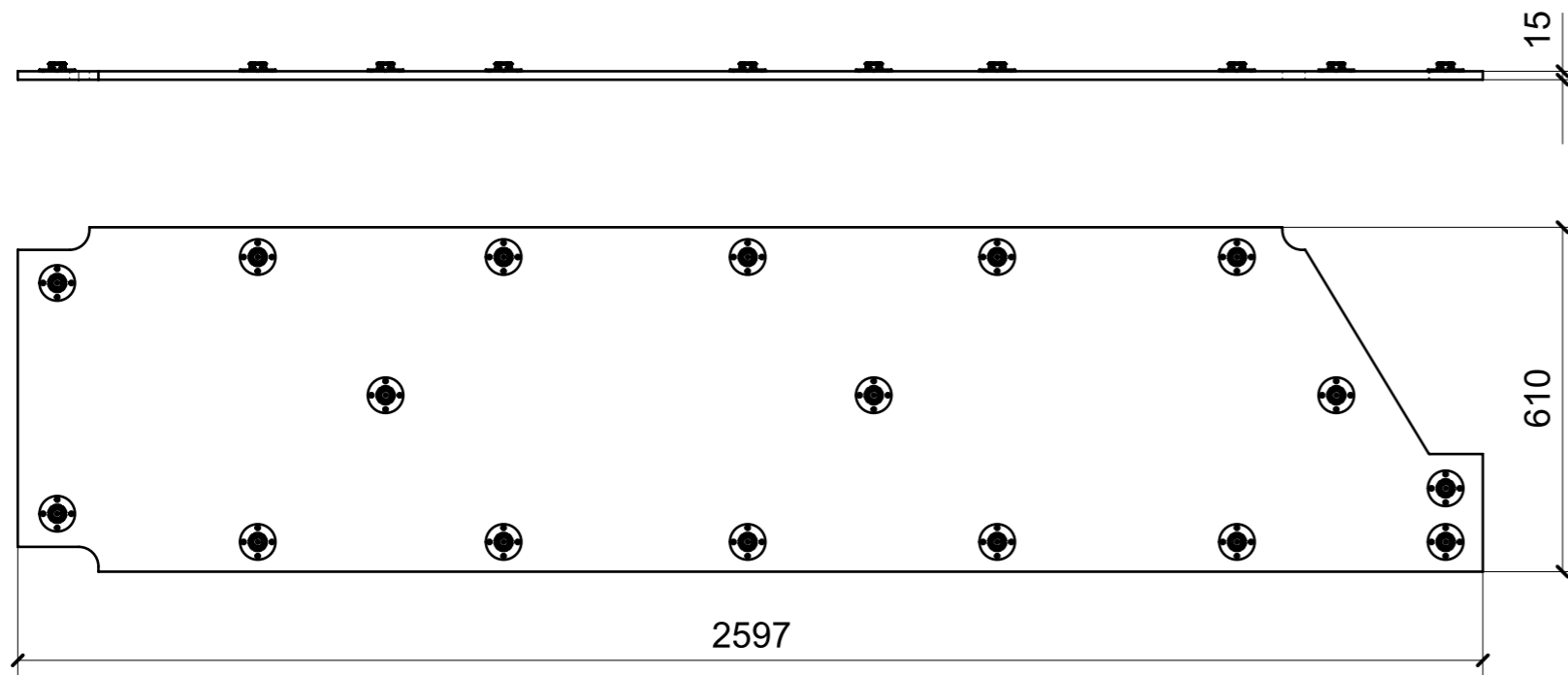

FERRAMENTA	QTY
FITLOCK M_MASCHERPA_3MM_6020202101	17

LOCALE	CODICE	DESCRIZIONE COMPONENTE	FINITURA	Q.TA
CABINA ARMATORE	MD299_I01_AY01	TESTALETTO_STD VAR 1	OKUME' GREZZO	1

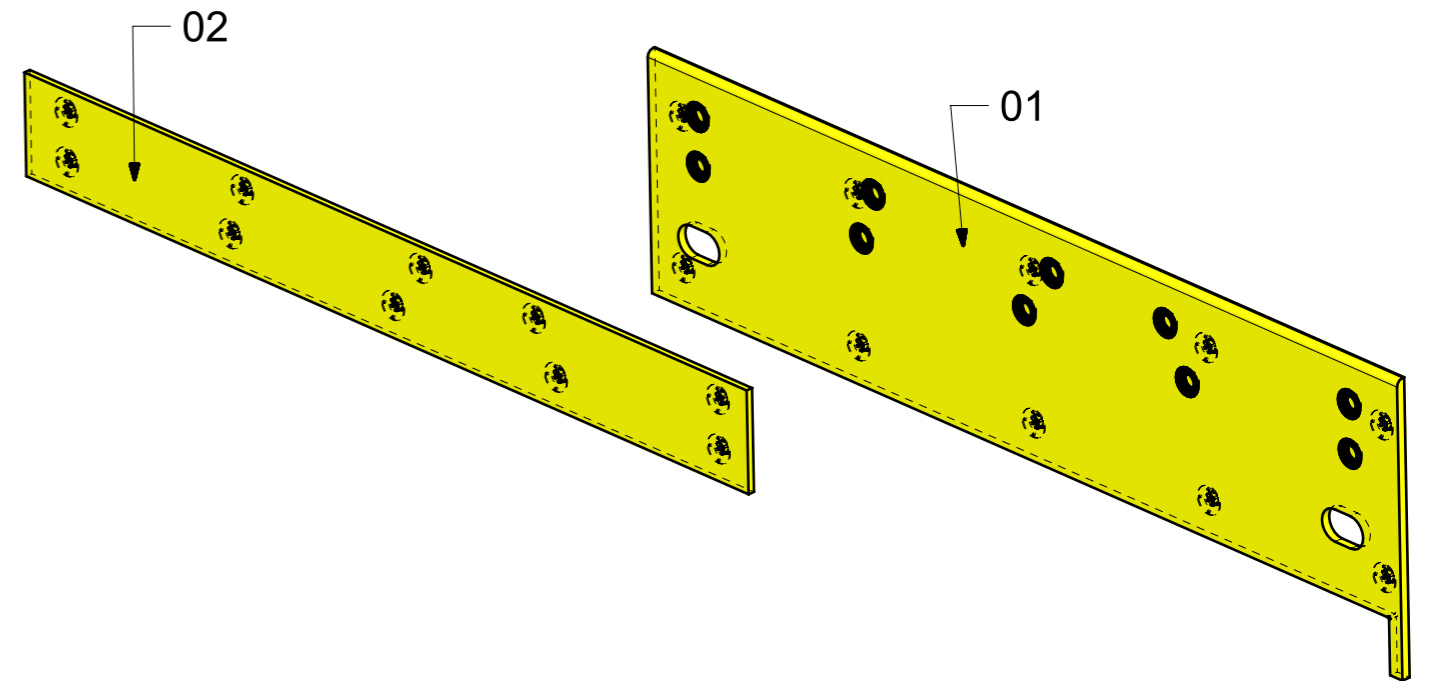
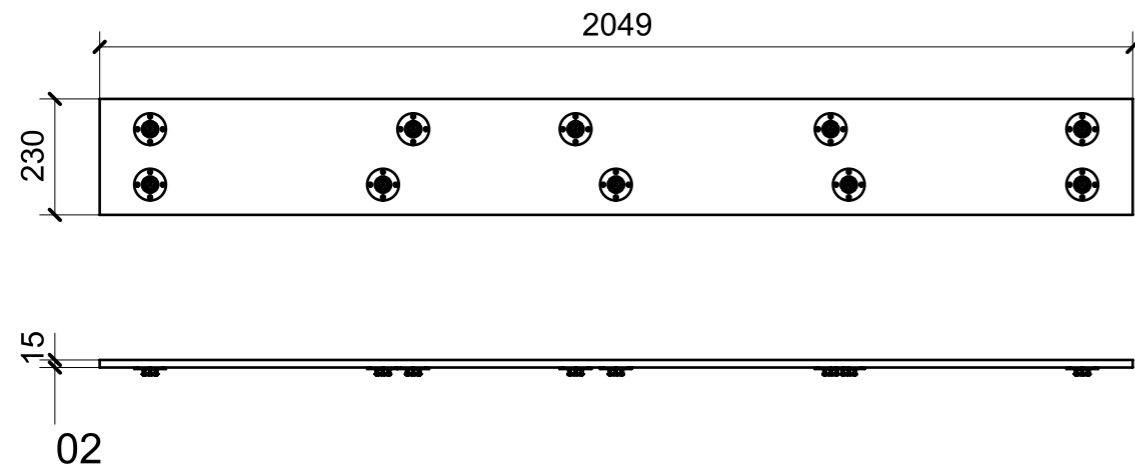
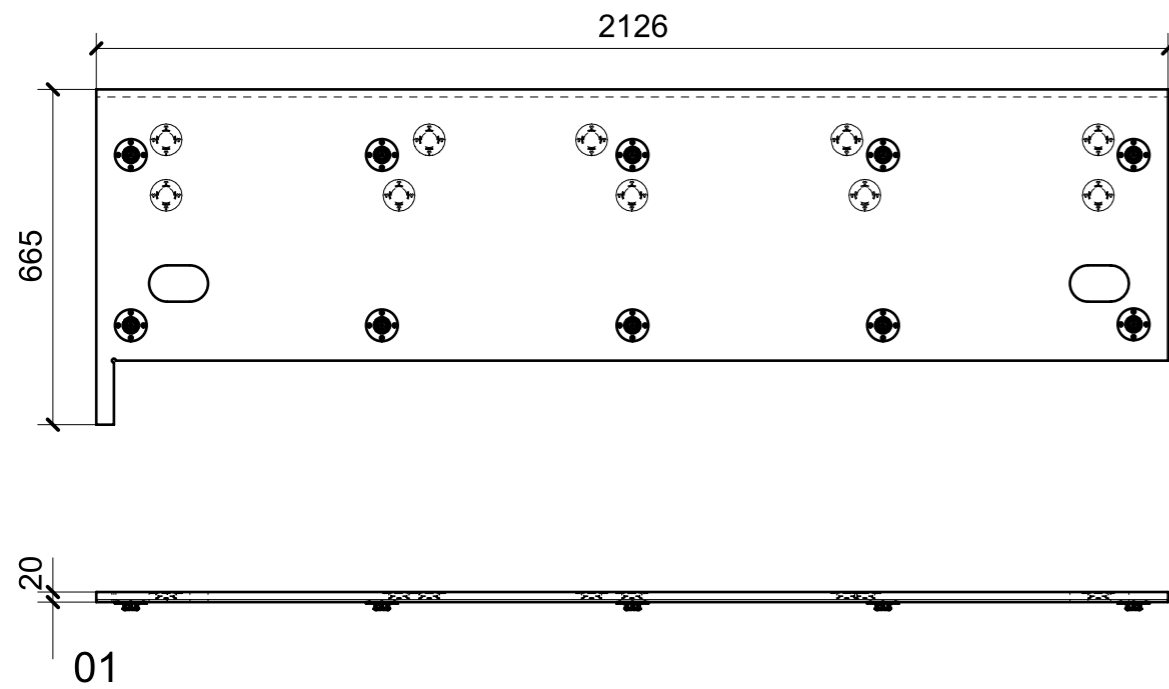

FERRAMENTA	QTY
FITLOCK F_MASCHERPA_6020101102	10
FITLOCK M_MASCHERPA_3MM_6020202101	20

LOCALE	CODICE	DESCRIZIONE COMPONENTE	FINITURA	Q.TA
CABINA ARMATORE	MD299_I01_AZ01	TESTALETTO_STD VAR 2	OKUME' GREZZO	1

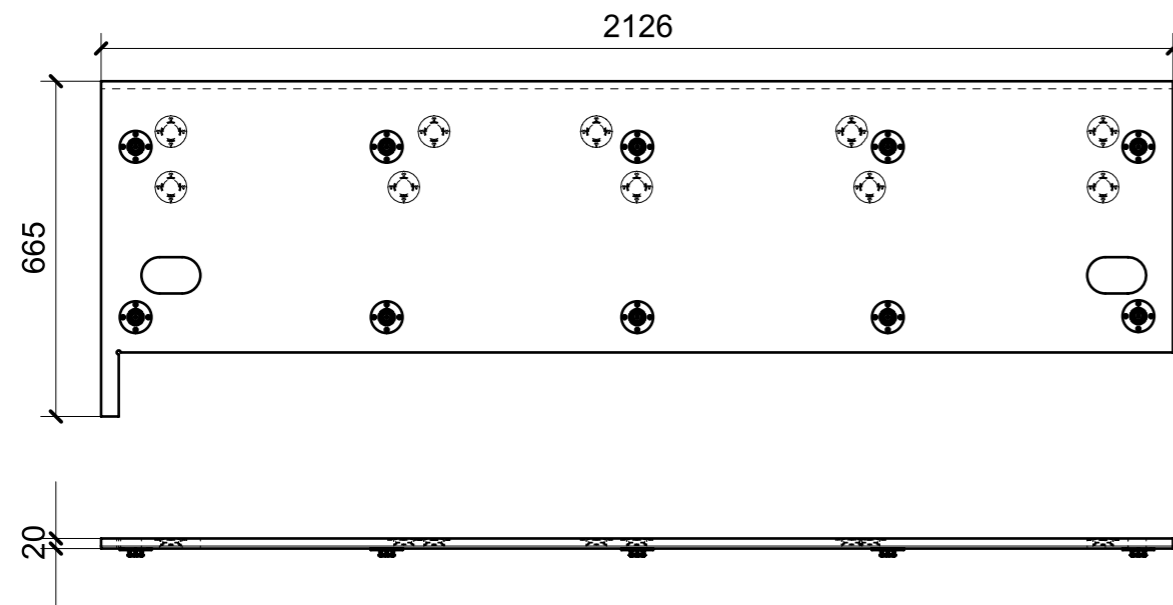

01

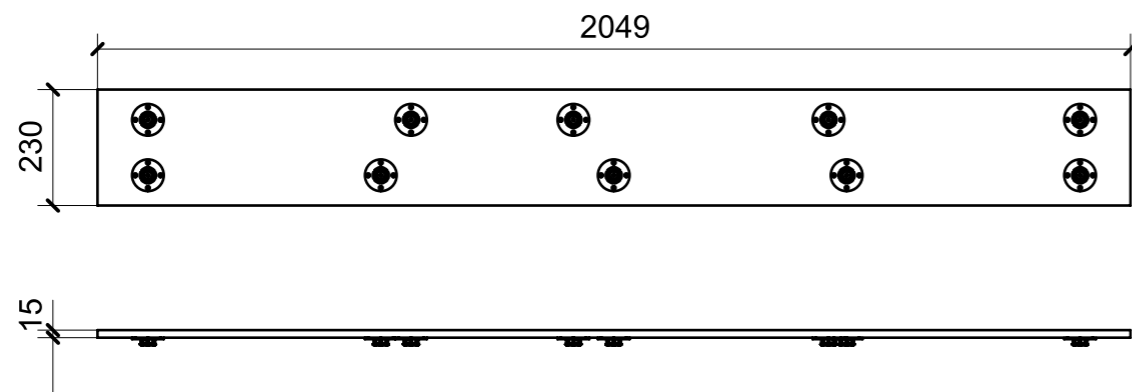

02

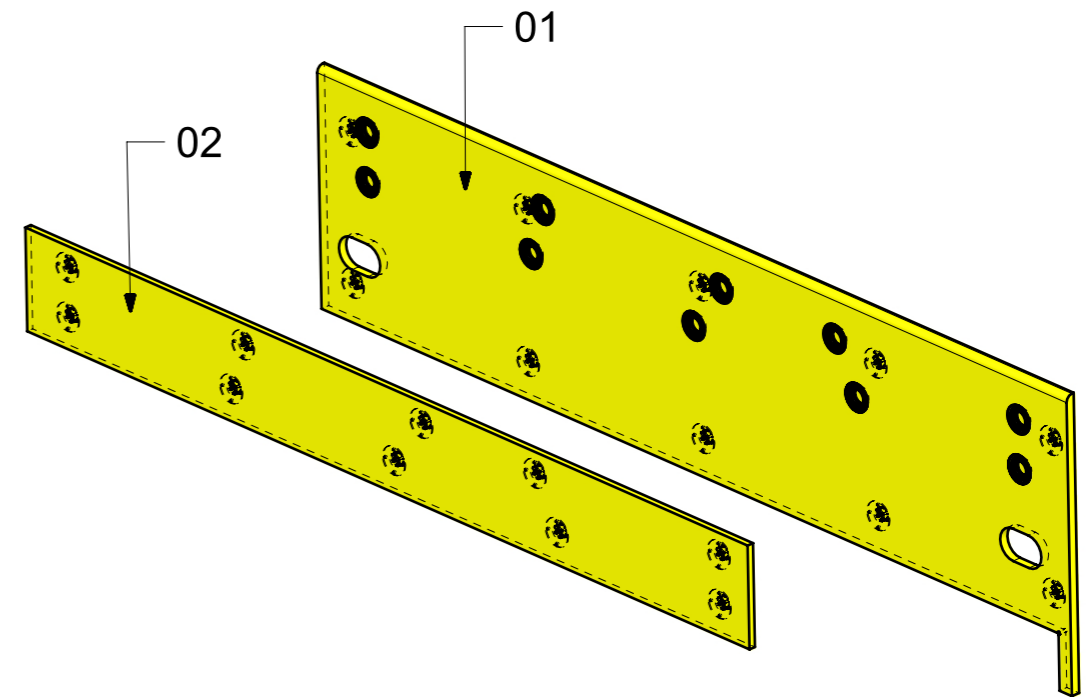

FERRAMENTA	QTY
FITLOCK F_MASCHERPA_6020101102	10
FITLOCK M_MASCHERPA_3MM_6020202101	20

LOCALE	CODICE	DESCRIZIONE COMPONENTE	FINITURA	Q.TA
CABINA ARMATORE	MD299_I01_AAP01	LETTO_STD VAR 2 EXTRASIZE	OKUME' GREZZO	1

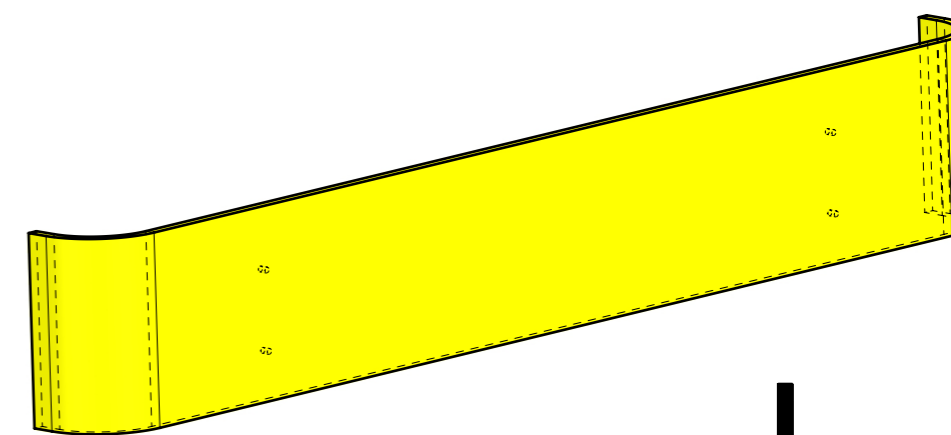
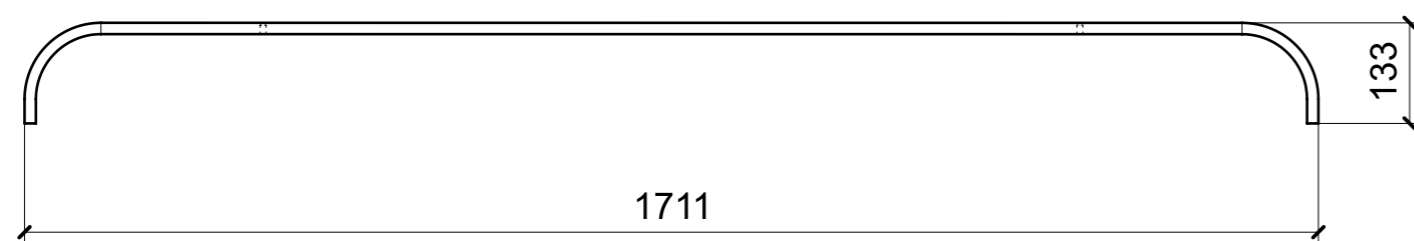
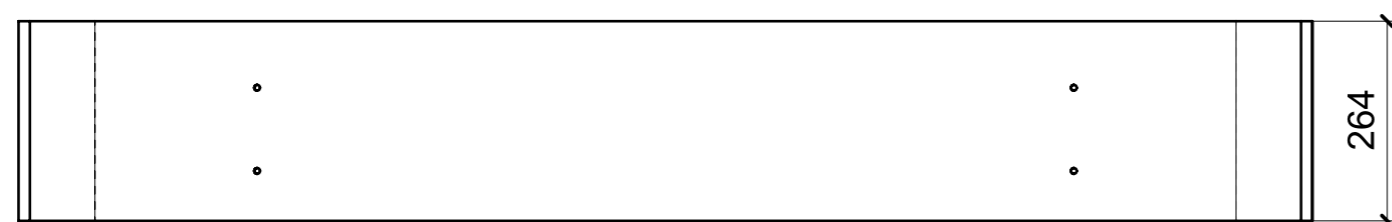

ELEMENTO DA MONTARE  
 con AAP01\_01/04 in MG\_AAP01  
 e spedire con unico imballo

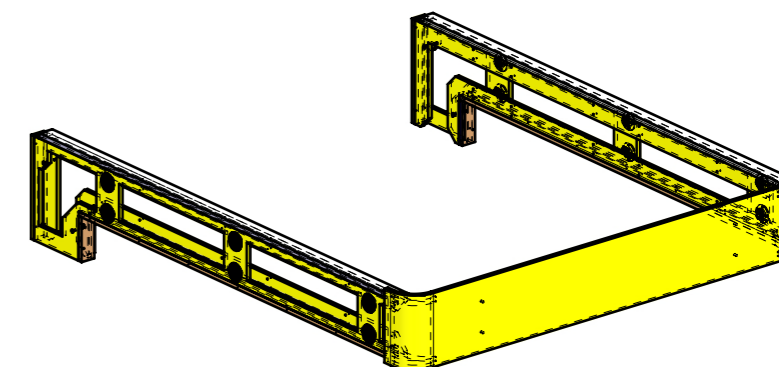

LOCALE	CODICE	DESCRIZIONE COMPONENTE	FINITURA	GR.
CABINA ARMATORE	MD299_I01_AAQ01	COMODINO SX_STD VAR 2	OKUME' GREZZO	16

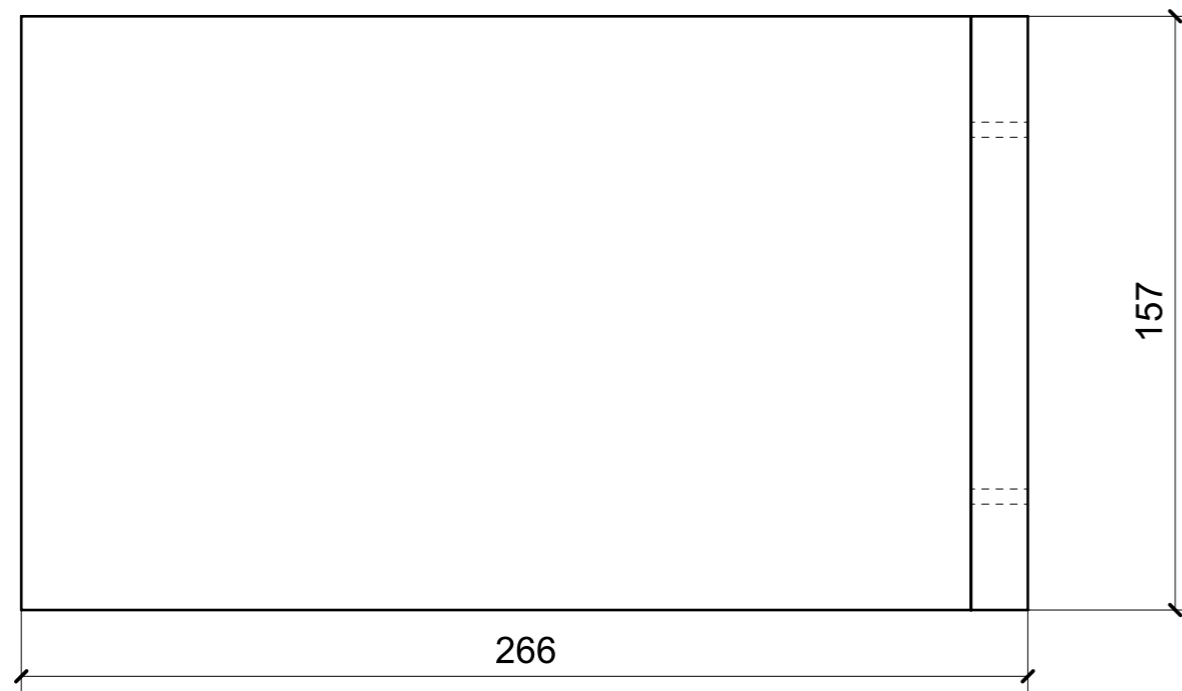
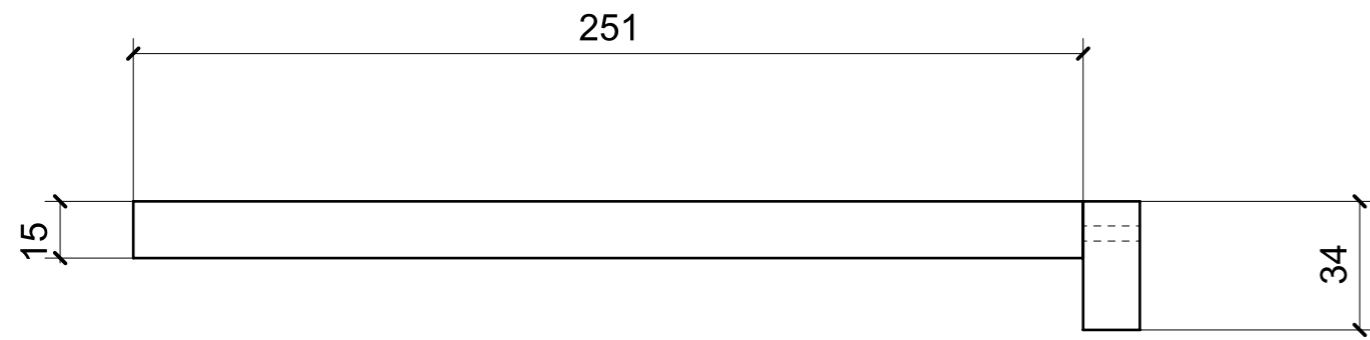

01

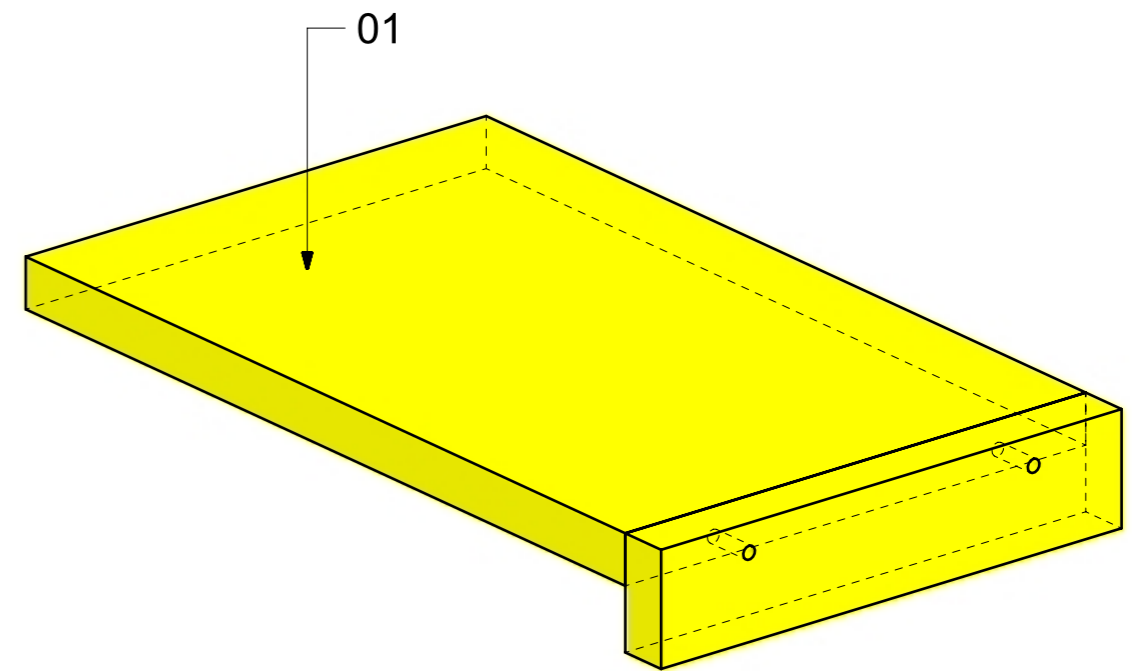

LOCALE	CODICE	DESCRIZIONE COMPONENTE	FINITURA	GR.
CABINA ARMATORE	MD299_I01_AAR01	COMODINO DX_STD VAR 2	OKUME' GREZZO	16

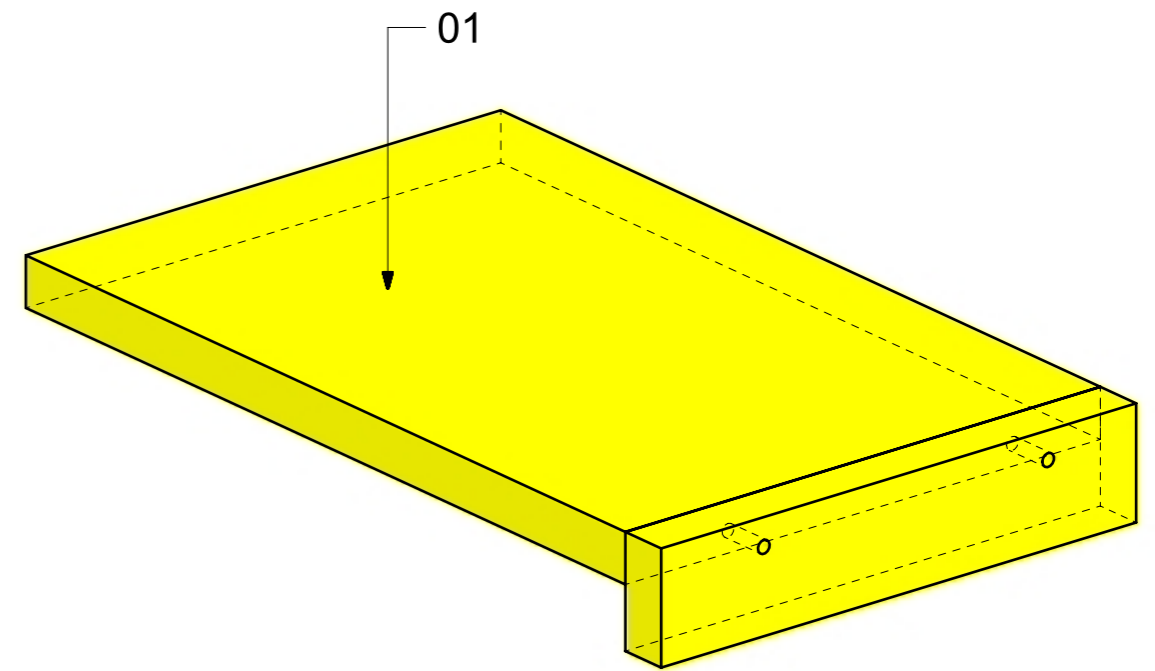
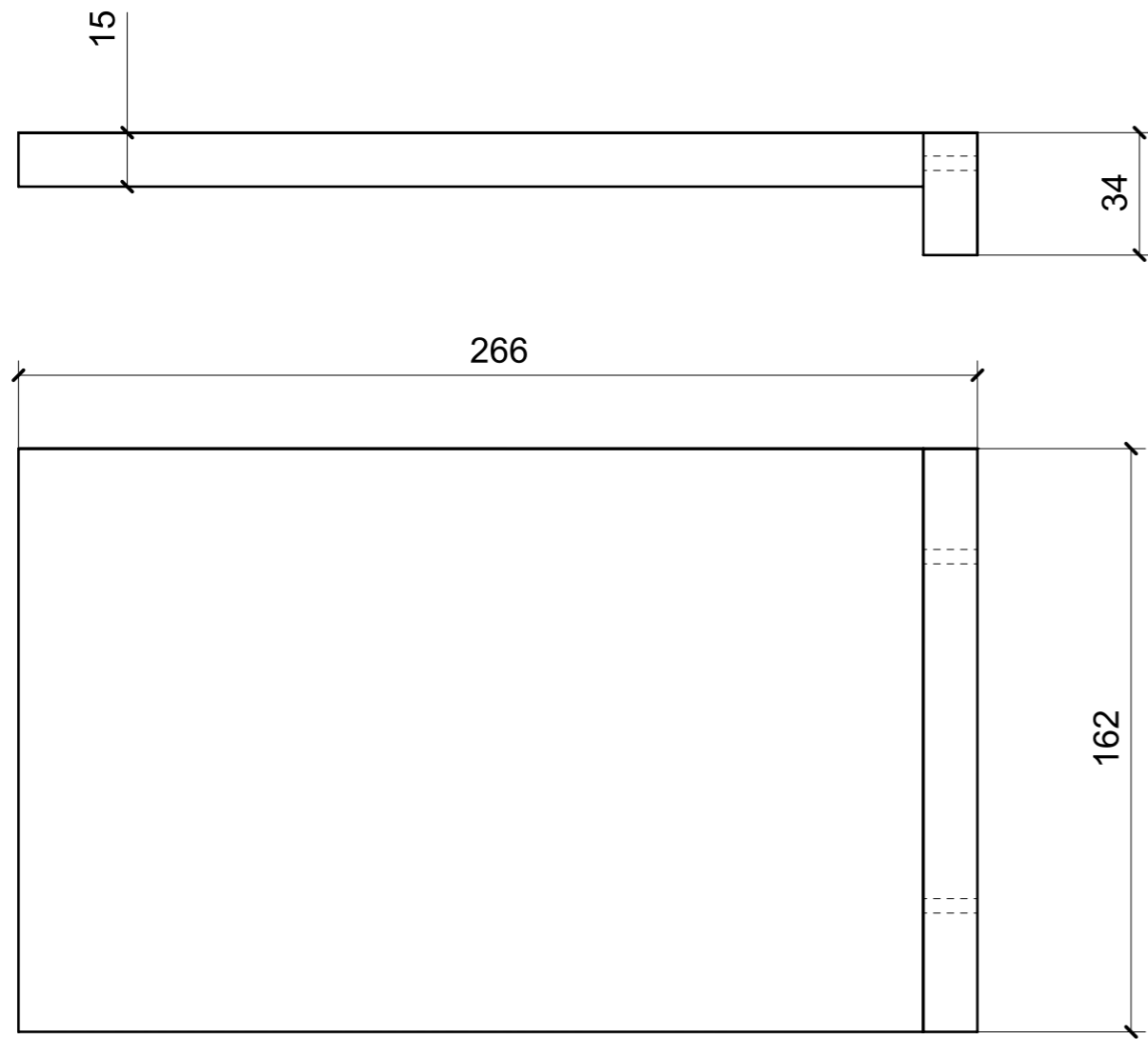

01