

LOCALE	CODICE	DESCRIZIONE COMPONENTE	FINITURA	GR.
CUCINA	MD320_MG_KC01	BASE CUCINA POPPA	LAMINATO SMART 0180-2 JUNGLE	3

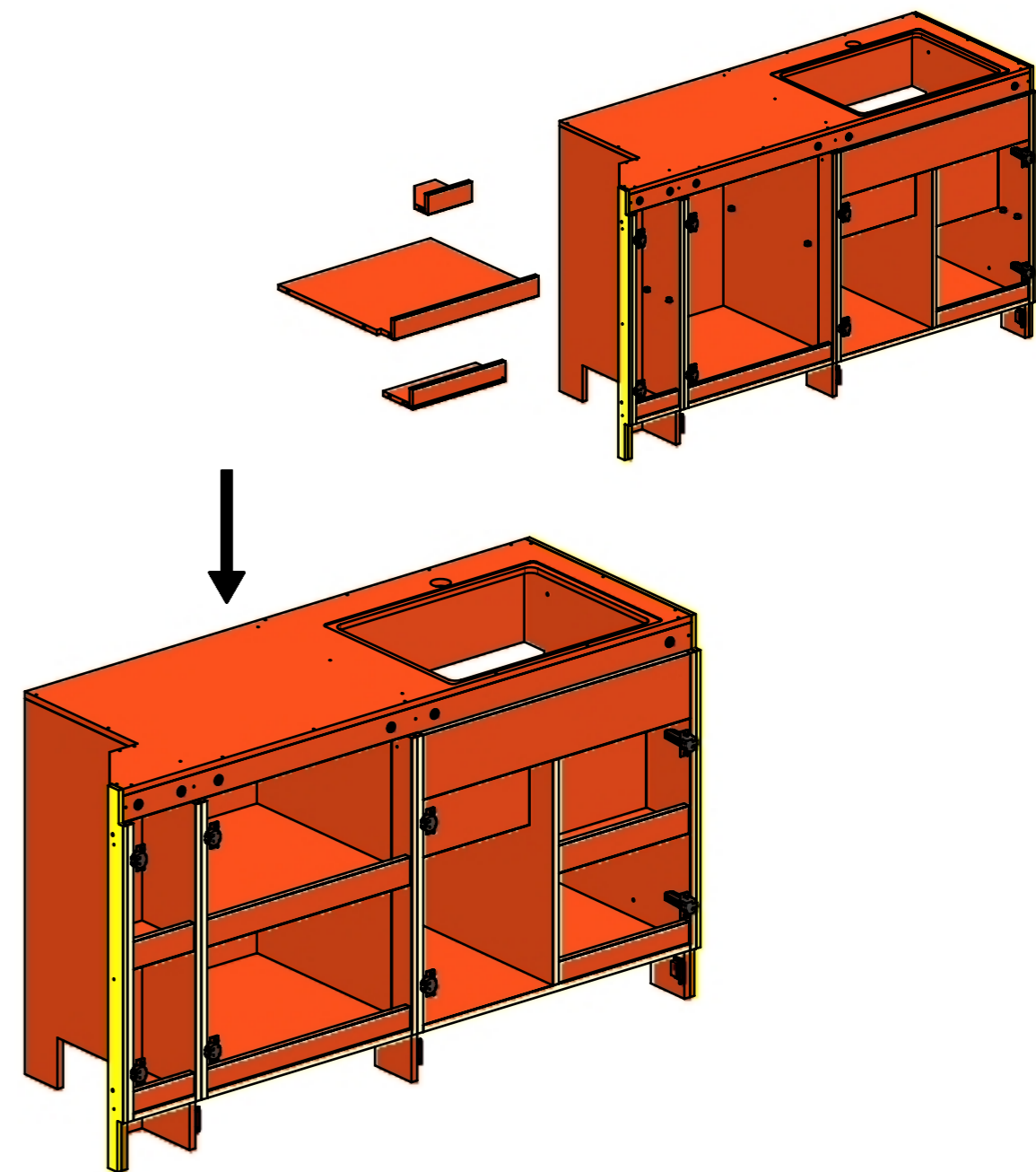

BASE_3-NERA_HAFELE_342.22.067-BLUM_175H3130.STP	8
BUSSOLA 5MA ANKOR BORGHI	16
CERNIERA 94°_PIANA-NERA_HAFELE_342.46.604-BLUM_71B9550.STP	8
CHIUSURA A SPINTA_TECHNOPARTNER_SOU C3-203	14
FM INCASSO_ITALVIPLA_973_FMPC_F1A	6
GIUNTO REGGIRIPIANO CON BORDO ANTISGANCIO_FBC BORGHI_1033XXB060902	16
PERNO LISCIO PER SPALLA_FBC BORGHI_1033PXX050531	16
VITE 4MAX8 ANKOR BORGHI	16

LOCALE	CODICE	DESCRIZIONE COMPONENTE	FINITURA	GR.
CUCINA	MD320_MG_KD01	PENSILE CUCINA POPPA		3

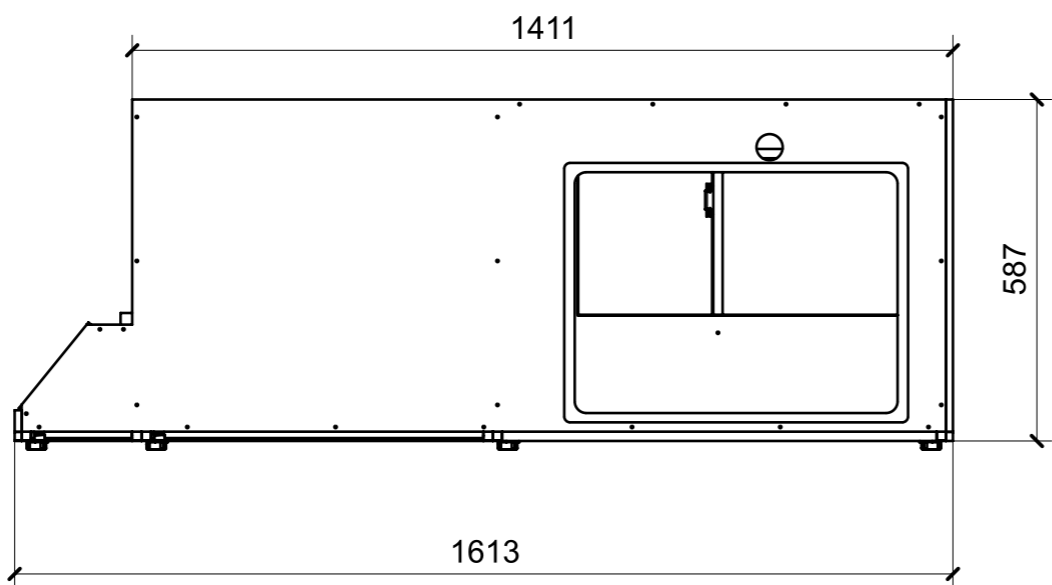
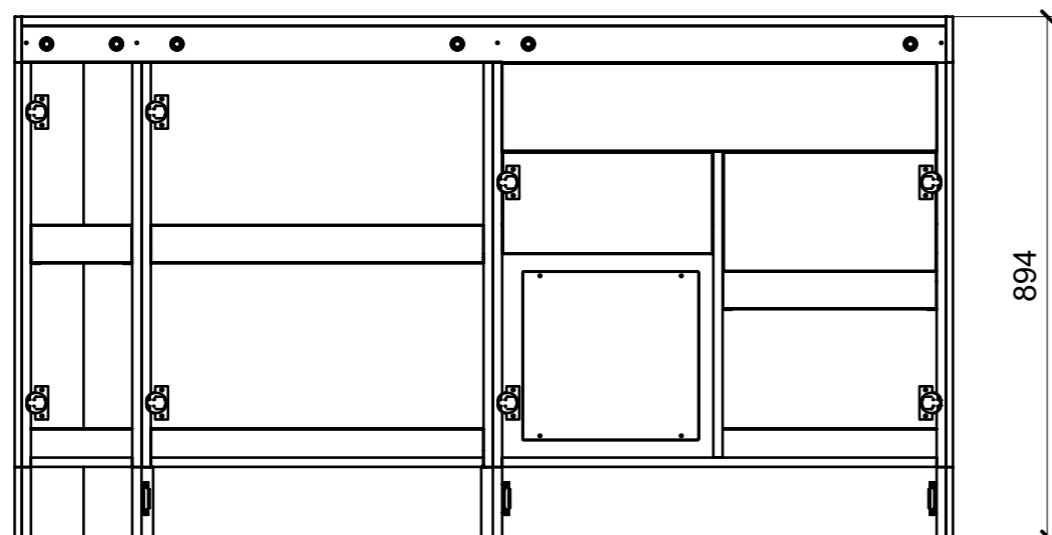
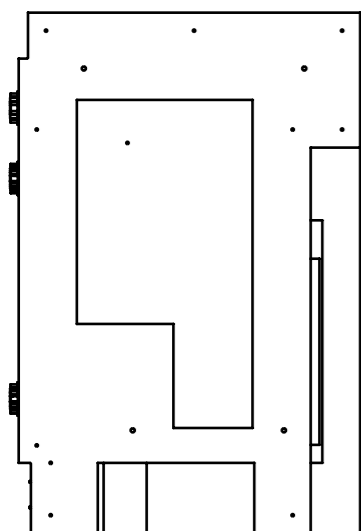
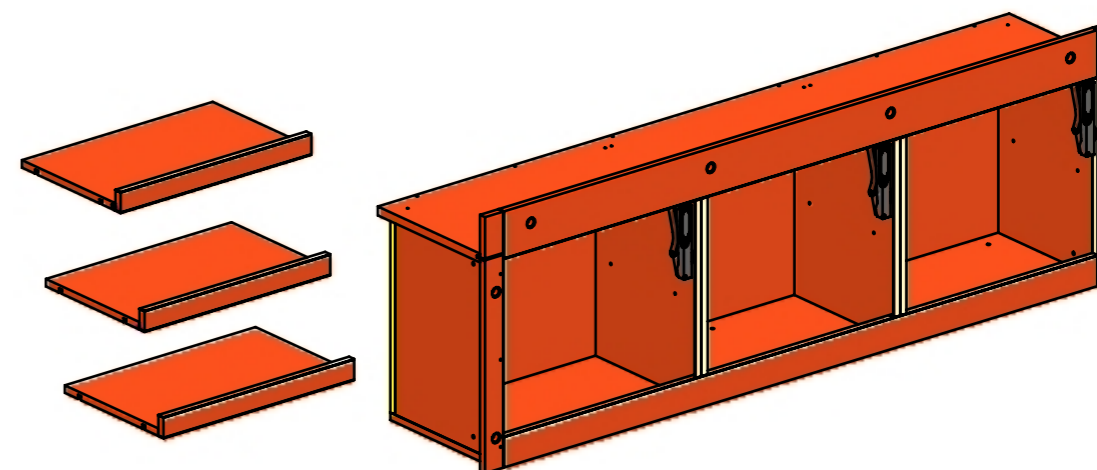
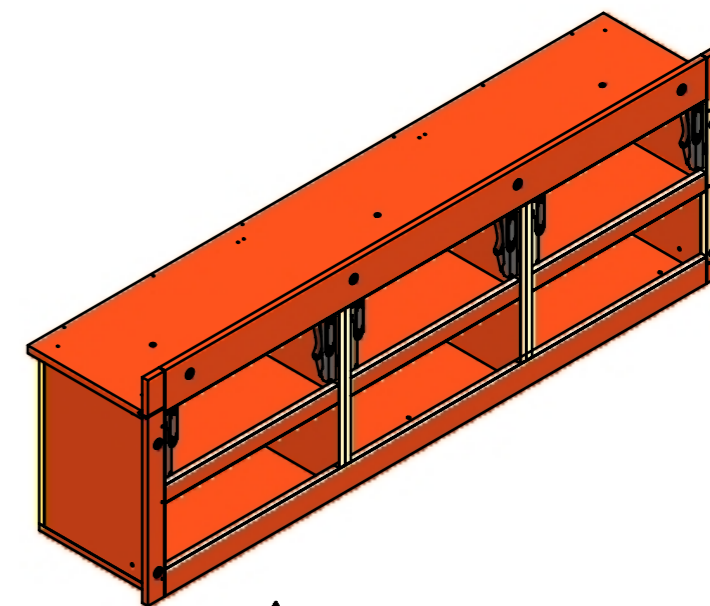
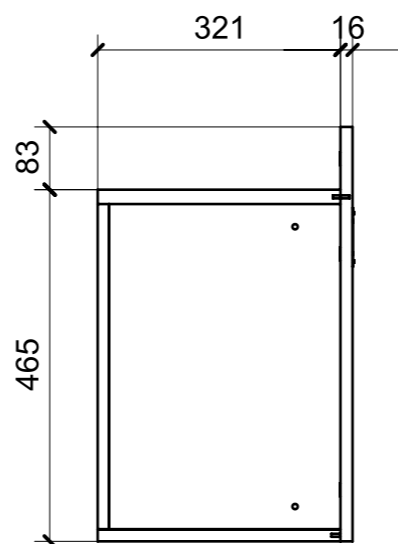
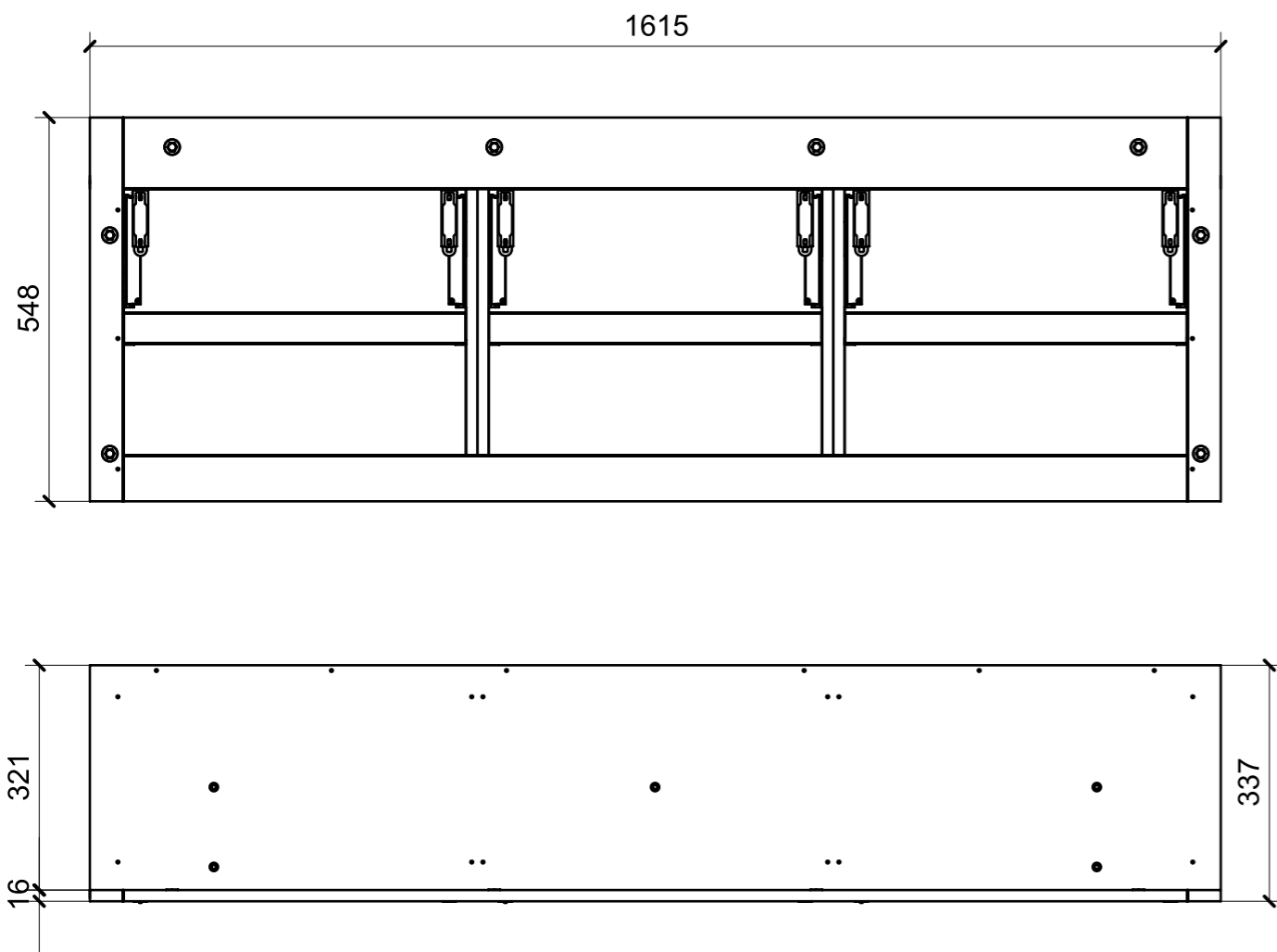

FERRAMENTA	QTY
BUSSOLA 6MA X 10 FORO DIAM.8	5
CP BRACCIO PER ANTA A RIBALTA _HAFELE FREE SPACE 1.11_372_27_301	3
FM INCASSO _ITALVIPLA_973_FMPC_F1A	8
GIUNTO REGGIRIPIANO CON BORDO ANTISGANCIO _FBC BORGHI_1033XXB060902	12
PERNO LISCIO PER SPALLA _FBC BORGHI_1033PXX050531	12

LOCALE	CODICE	DESCRIZIONE COMPONENTE	FINITURA	GR.
CUCINA	MD320_MG_KFF01	FORNO 60_Var 1		2

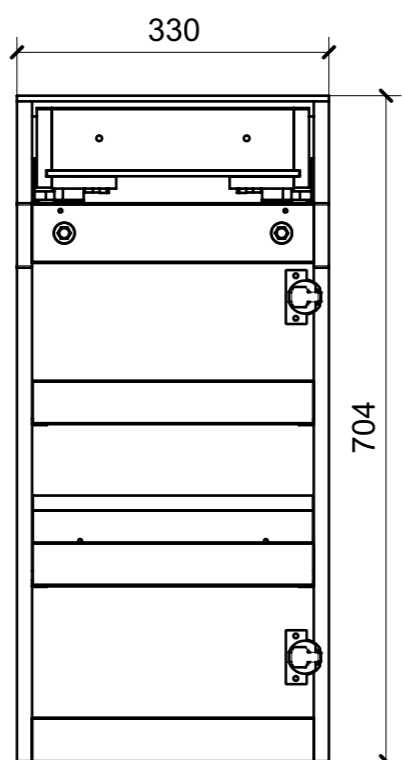
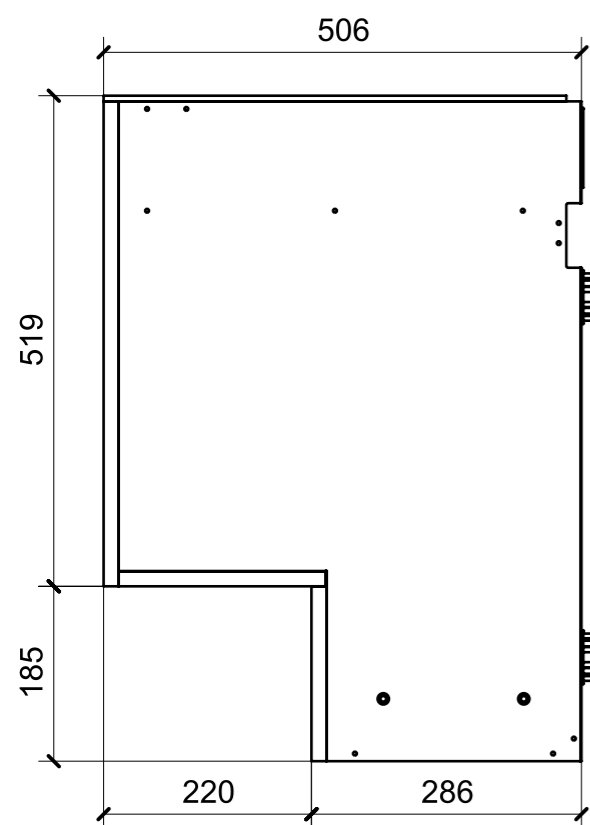
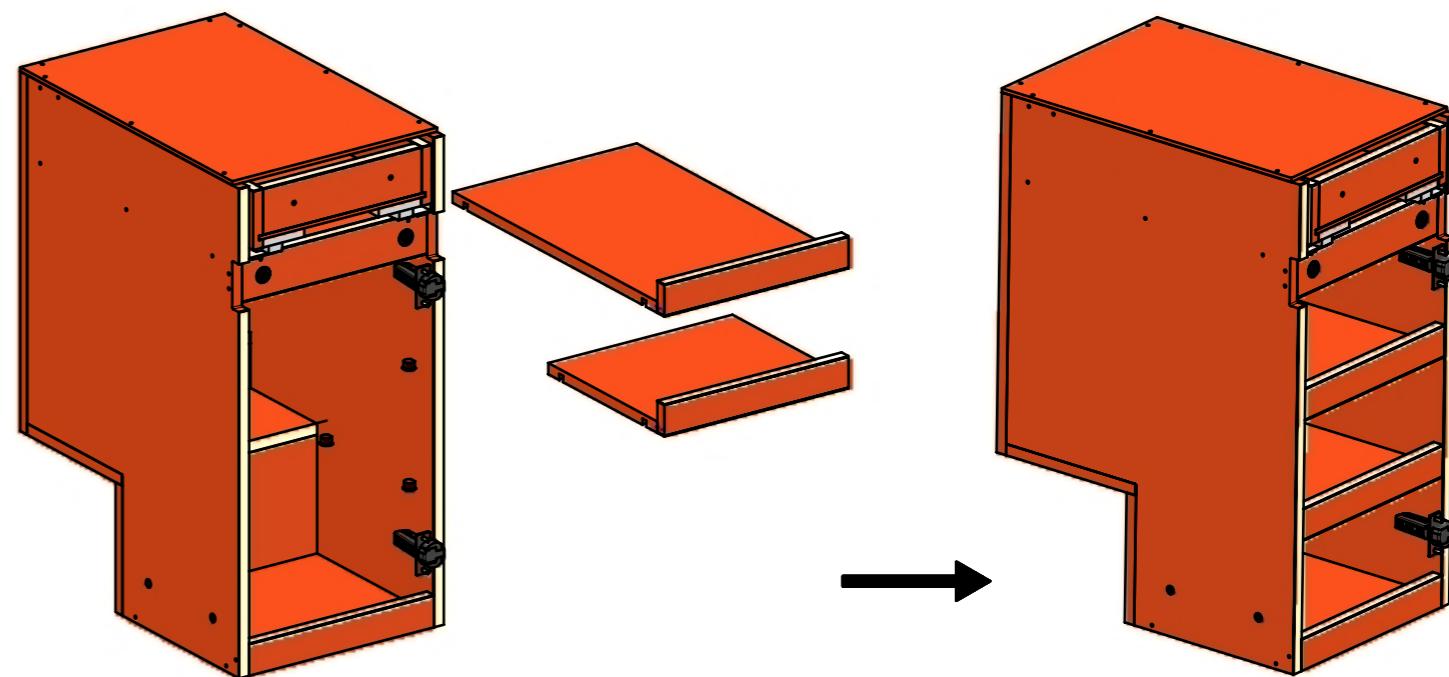
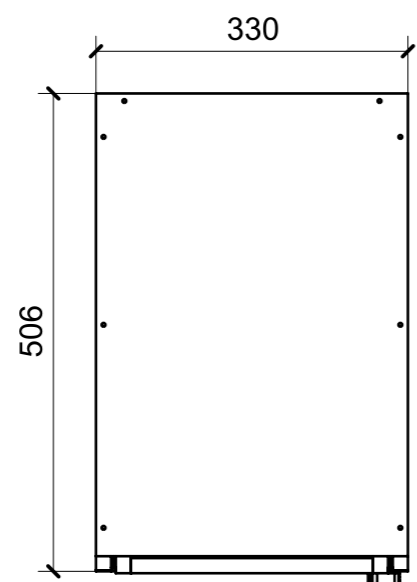

FERRAMENTA	QTY
BASE_3-NERA_HAFELE_342.22.067-BLUM_175H3130.STP	2
BUSSOLA 5MA ANKOR BORGHI	4
BUSSOLA 6MA X 10 FORO DIAM.8	2
CALAMITA SEALED MAGNETIC_TECNOPARTNER_MC-JM50-BL	2
CERNIERA 94°_PIANA-NERA_HAFELE_342.46.604-BLUM_71B9550.STP	2
FM INCASSO_ITALVIPLA_973_FMPC_F1A	2
GIUNTO REGGIRIPIANO CON BORDO ANTISGANCIO_FBC BORGHI_1033XXB060902	8
GUIDA DYNAPRO ADJUSTAMENT ADAPTER L_FBC_F134141746 4D	2
GUIDA DYNAPRO ADJUSTAMENT ADAPTER R_FBC_F134141746 4D	2
GUIDA DYNAPRO FRONT LOCKING DEVICE L_FBC_F134108955 4D	2
GUIDA DYNAPRO FRONT LOCKING DEVICE R_FBC_F134108955 4D	2
GUIDA DYNAPRO SOFTCLOSE L250 L_FBC_F130107790 4D	1
GUIDA DYNAPRO SOFTCLOSE L250 R_FBC_F130107790 4D	1
GUIDA DYNAPRO SOFTCLOSE L400 L_FBC_F130107808 4D	1
GUIDA DYNAPRO SOFTCLOSE L400 R_FBC_F130107808 4D	1
PERNO LISCIO PER SPALLA_FBC BORGHI_1033PXX050531	8
PLACCHETTA COUNTER STEEL_TECNOPARTNER_MC-JM49	2
VITE 4MAX8 ANKOR BORGHI	4

LOCALE	CODICE	DESCRIZIONE COMPONENTE	FINITURA	GR.
CUCINA	MD320_MG_KFF02	FORNO 60_Var 1		2

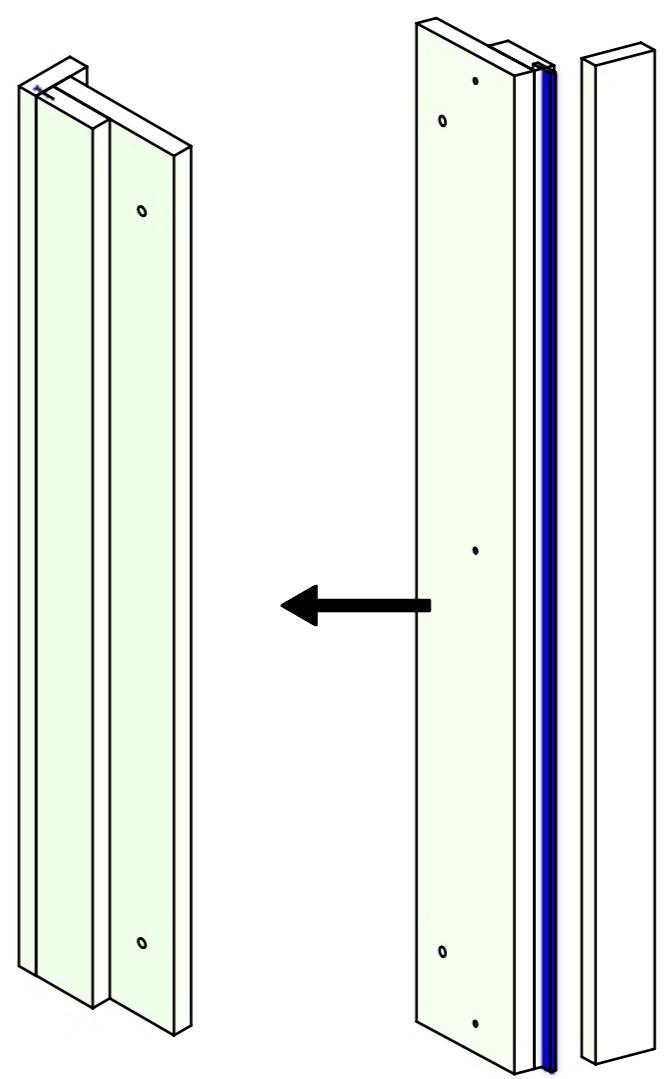
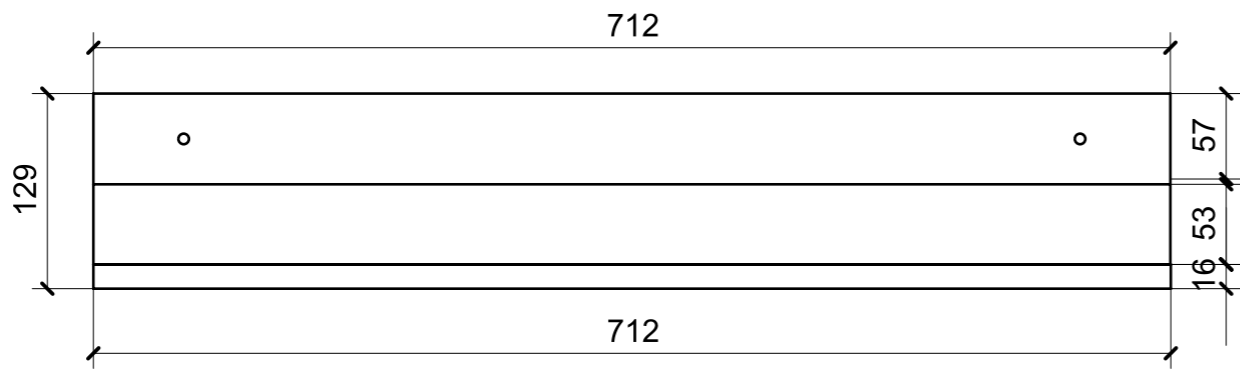
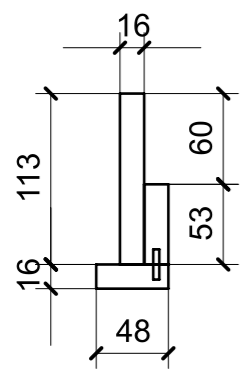

LOCALE	CODICE	DESCRIZIONE COMPONENTE	FINITURA	GR.
CUCINA	MD320_MG_KKF01	FORNO 90_Var 2		2

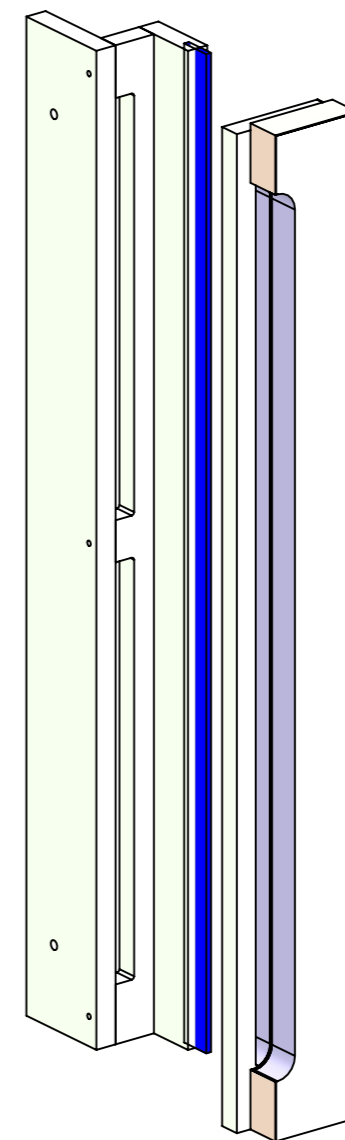
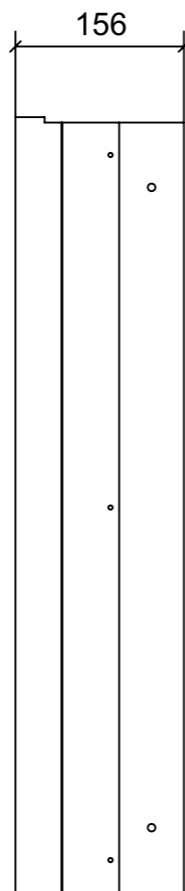
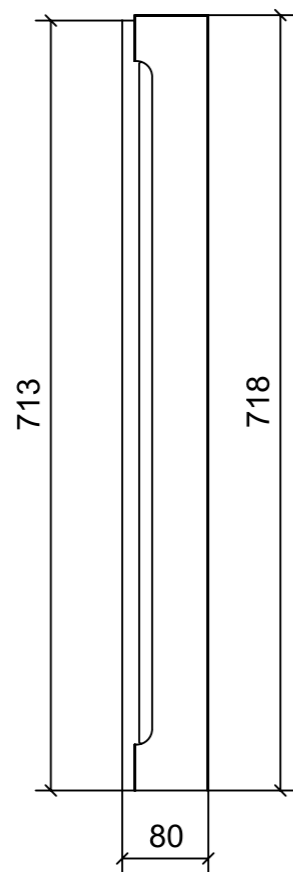
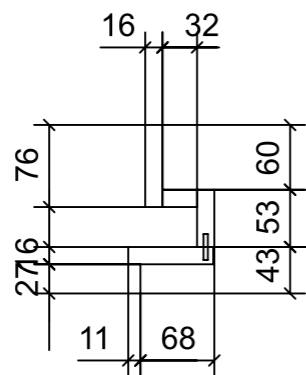

LOCALE	CODICE	DESCRIZIONE COMPONENTE	FINITURA	GR.
CUCINA	MD320_MG_KG01	PENSILE CUCINA PRUA versione 60-90		3

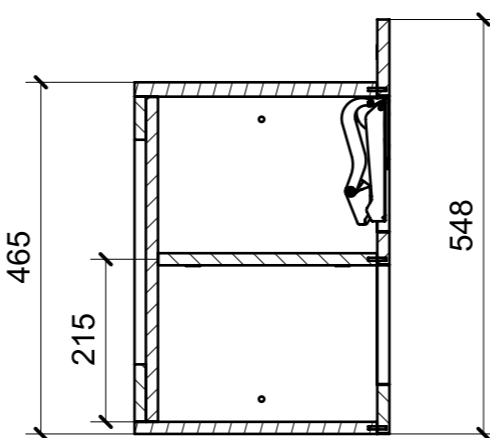
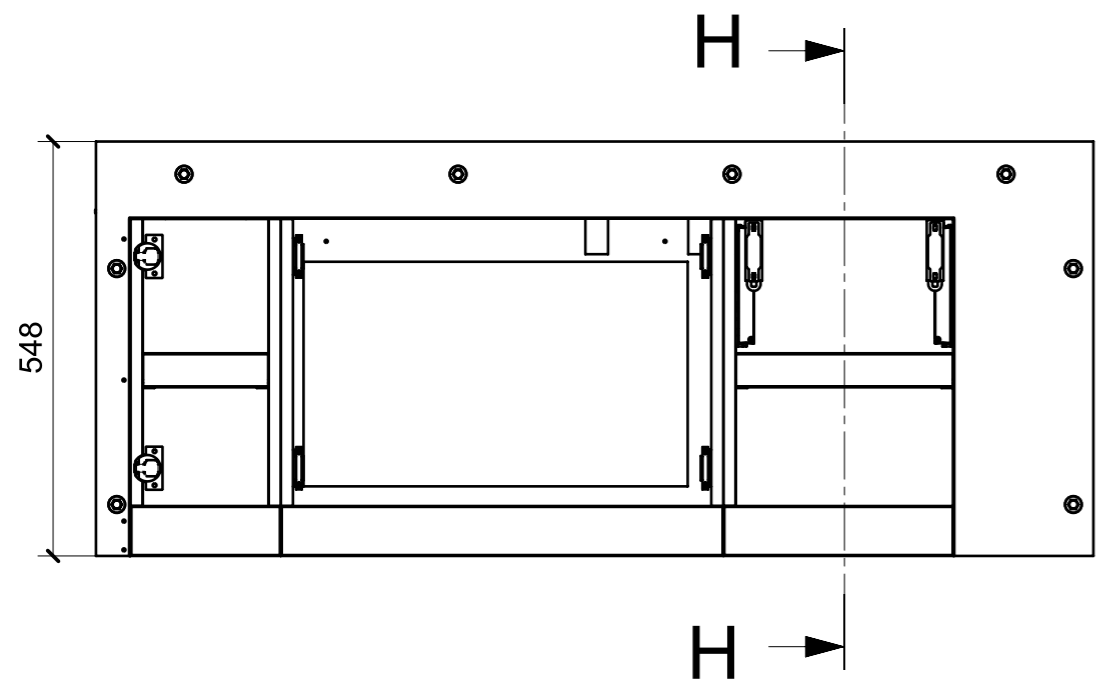
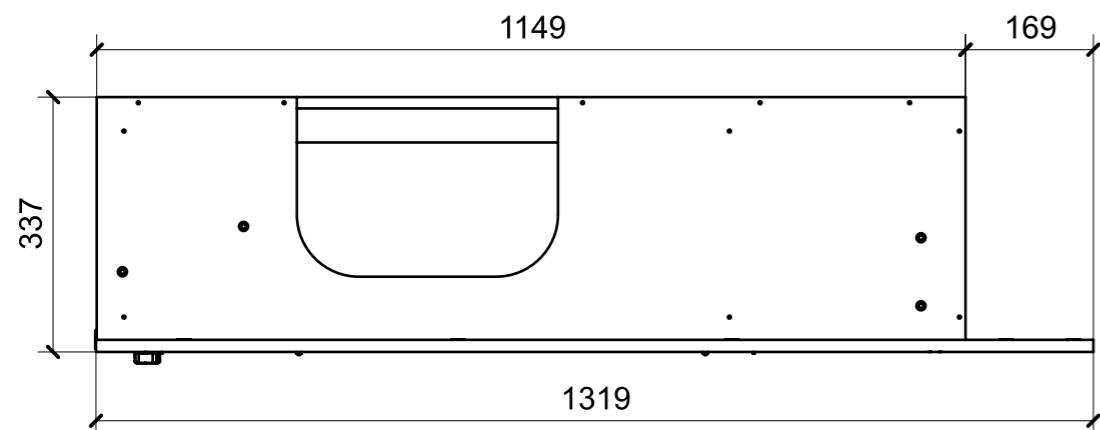

SECTION H-H

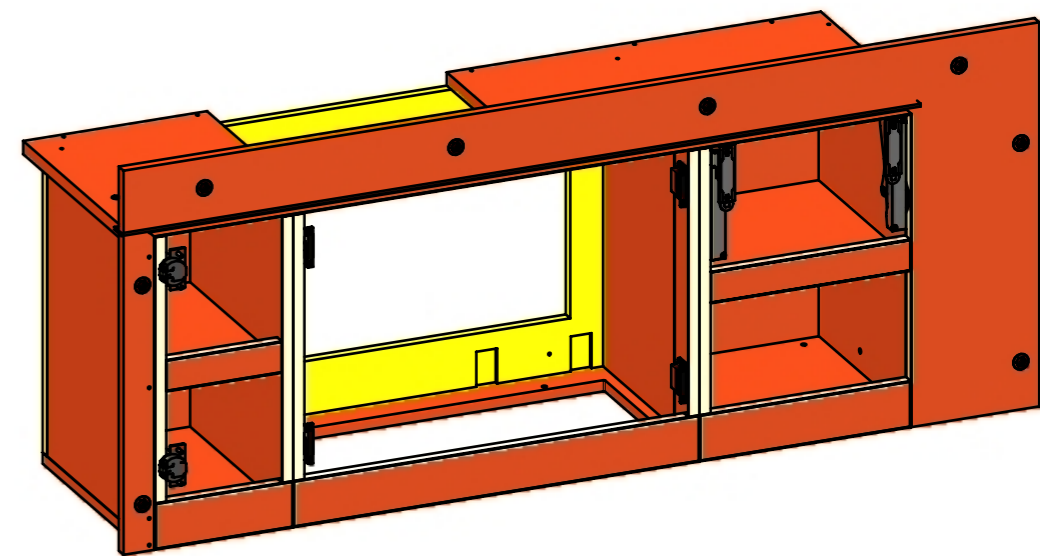
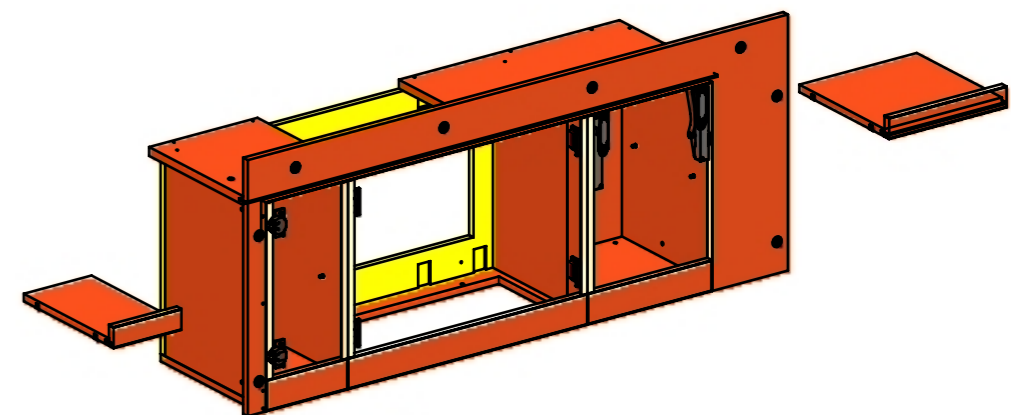

FERRAMENTA	QTY
BASE_0-NERA_HAFELE_342.22.065-BLUM_175H3100.STP	2
BUSSOLA 5MA ANKOR BORGHI X BASE 0	4
BUSSOLA 6MA X 10 FORO DIAM.8	4
CERNIERA 94°_PIANA-NERA_HAFELE_342.46.604-BLUM_71B9550.STP	2
CHIUSURA A SPINTA_TECHNOPARTNER_SOU C3-203	4
CP BRACCIO PER ANTA A RIBALTA_HAFELE FREE SPACE 1.11_372_27_301	1
FM INCASSO_ITALVIPLA_973_FMPC_F1A	8
GIUNTO REGGIRIPIANO CON BORDO ANTISGANCIO_FBC BORGHI_1033XXB060902	8
PERNO LISCIO PER SPALLA_FBC BORGHI_1033PXX050531	8
VITE 4MAX8 ANKOR BORGHI X BASE 0	4

LOCALE	CODICE	DESCRIZIONE COMPONENTE	FINITURA	GR.
CUCINA	MD320_MG_KKA01/02	FAGGIO E GOMMA STANDARD		2

**MF\_KKA01**

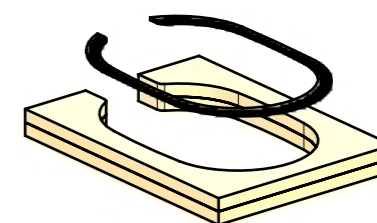
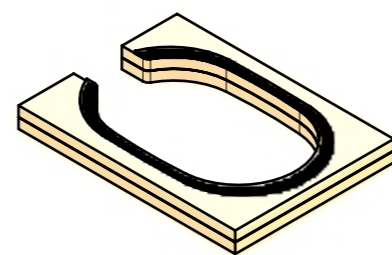
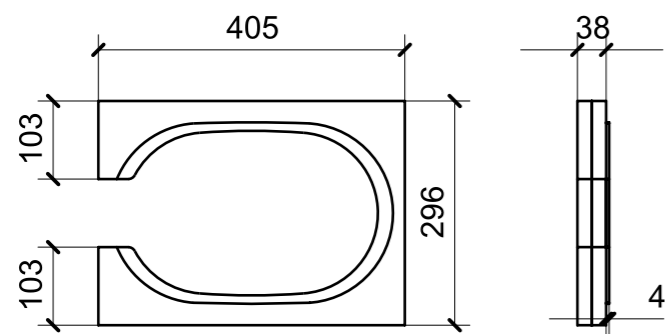

**MF\_KKA02**

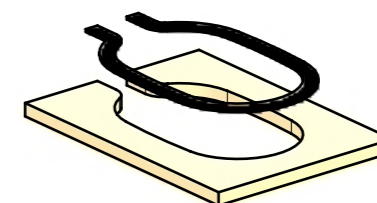
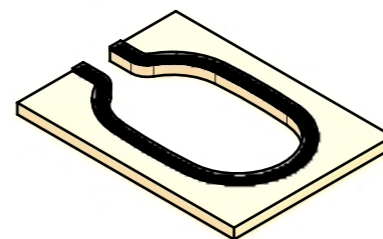
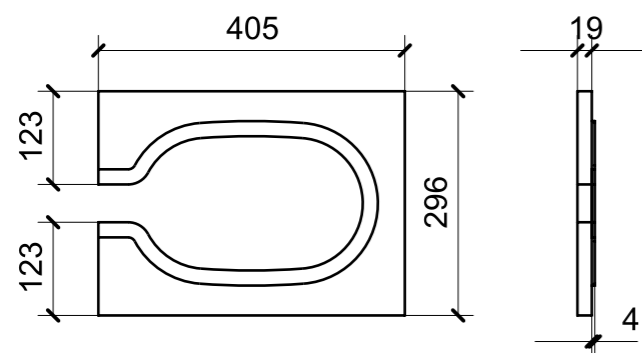

LOCALE	CODICE	DESCRIZIONE COMPONENTE	FINITURA	GR.
CUCINA	MD320_MG_KL01	MOBILE PORTABICCHIERI		3

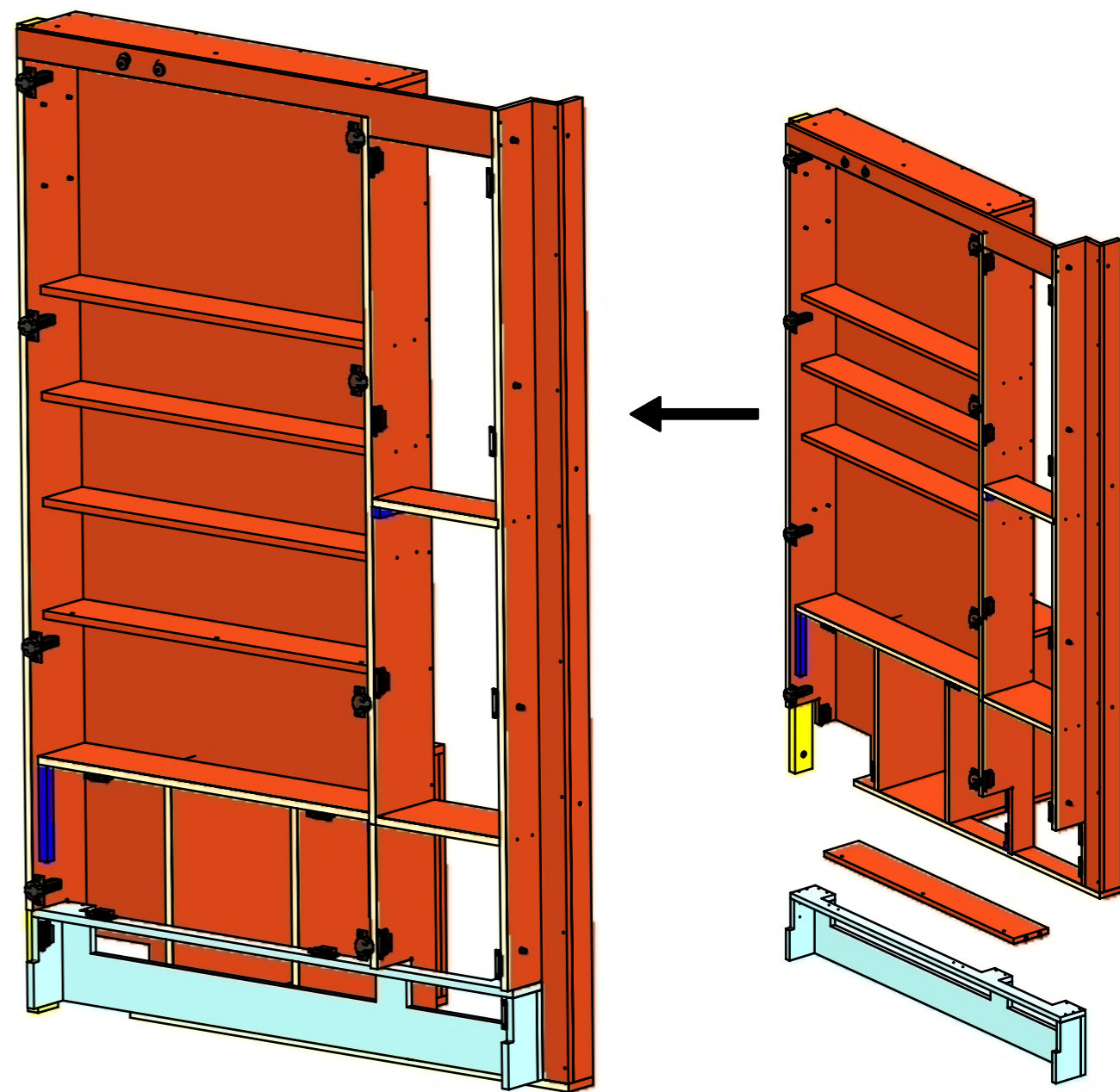
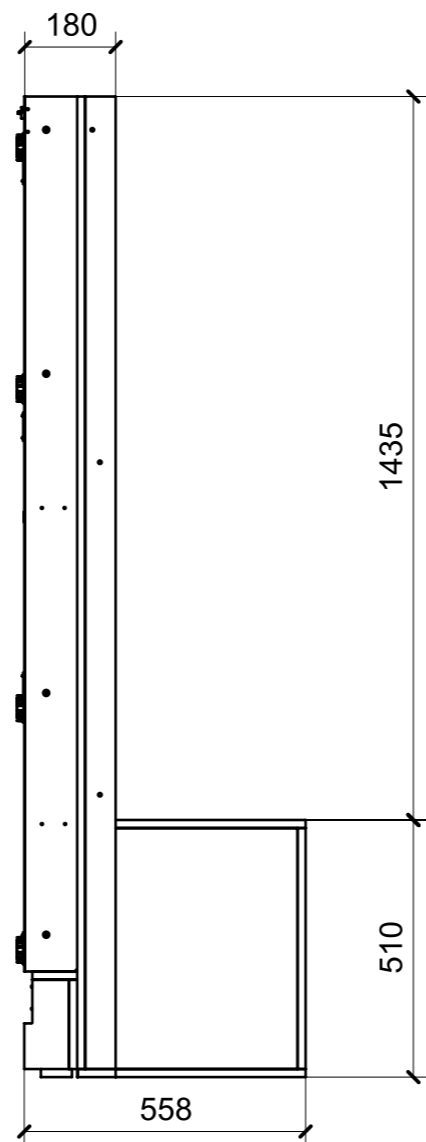
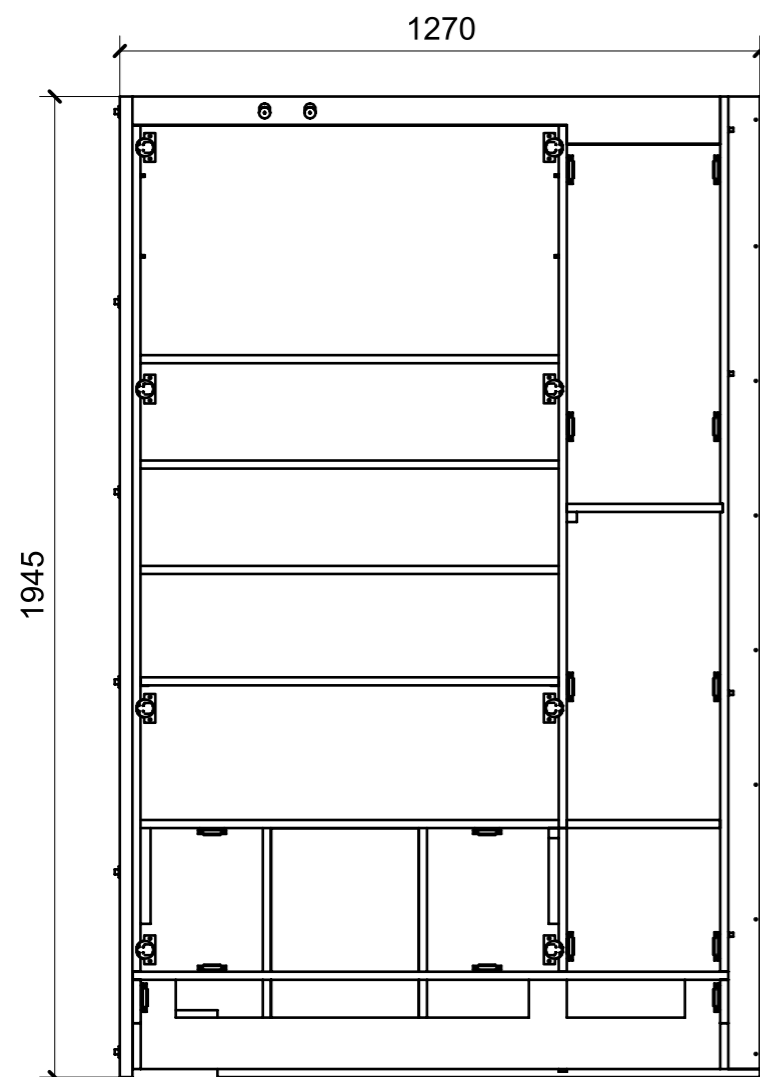
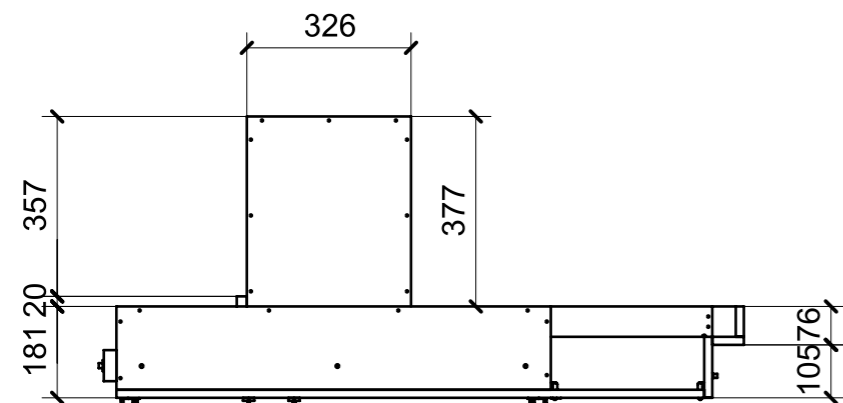

FERRAMENTA	QTY
BASE_3-NERA_HAFELE_342.22.067-BLUM_175H3130.STP	8
BUSSOLA 5MA ANKOR BORGHI	16
BUSSOLA 5MA ANKOR BORGHI X CERNIERA PIANA	16
BUSSOLA 6MA X 10 FORO DIAM.8	12
CERNIERA 94°_PIANA-NERA_HAFELE_342.46.604-BLUM_71B9550.STP	8
CHIUSURA A SPINTA_TECHNOPARTNER_SOU C3-203	24
FM INCASSO_ITALVIPLA_973_FMPC_F1A	6
GIUNTO REGGIRIPIANO CON BORDO ANTISGANCIO_FBC BORGHI_1033XXB060902	4
MAGNETE FORZA MAGNETICA1-5 10KG_HAFELE_246.87.112	4
MS INCASSO_ITALVIPLA_972_FMPC_M1B	6
PERNO LISCIO PER SPALLA_FBC BORGHI_1033PXX050531	13
VITE 4MAX8 ANKOR BORGHI	16
VITE 6MA X 25 TESTA BOMBATA NERA BHCS 10.9 ISO 7380	3
VITE 6MA X 30 TESTA SVASATA	5

LOCALE	CODICE	DESCRIZIONE COMPONENTE	FINITURA	GR.
CUCINA	MD320_MG_KL02-03	MOBILE PORTABICCHIERI		3

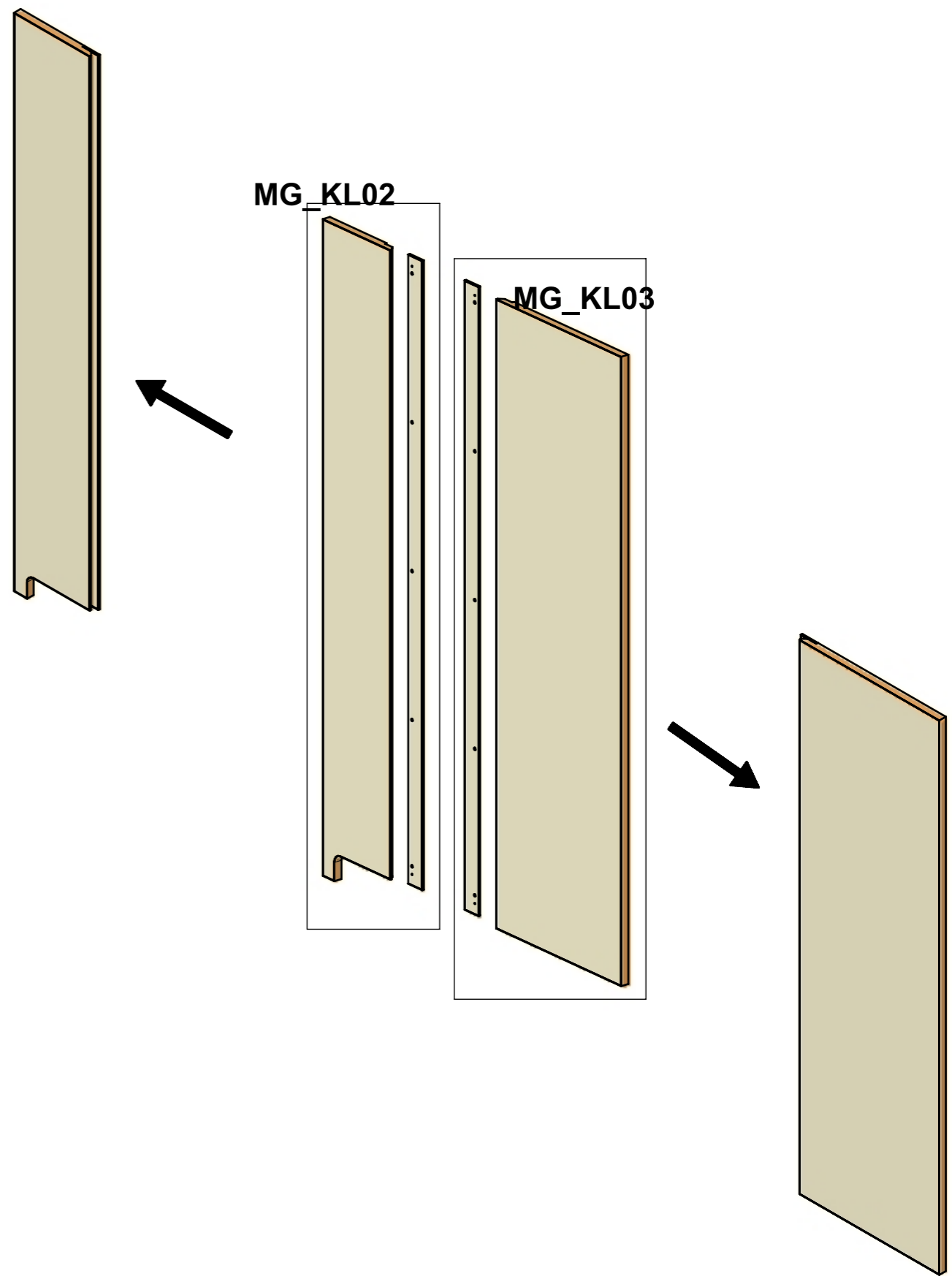
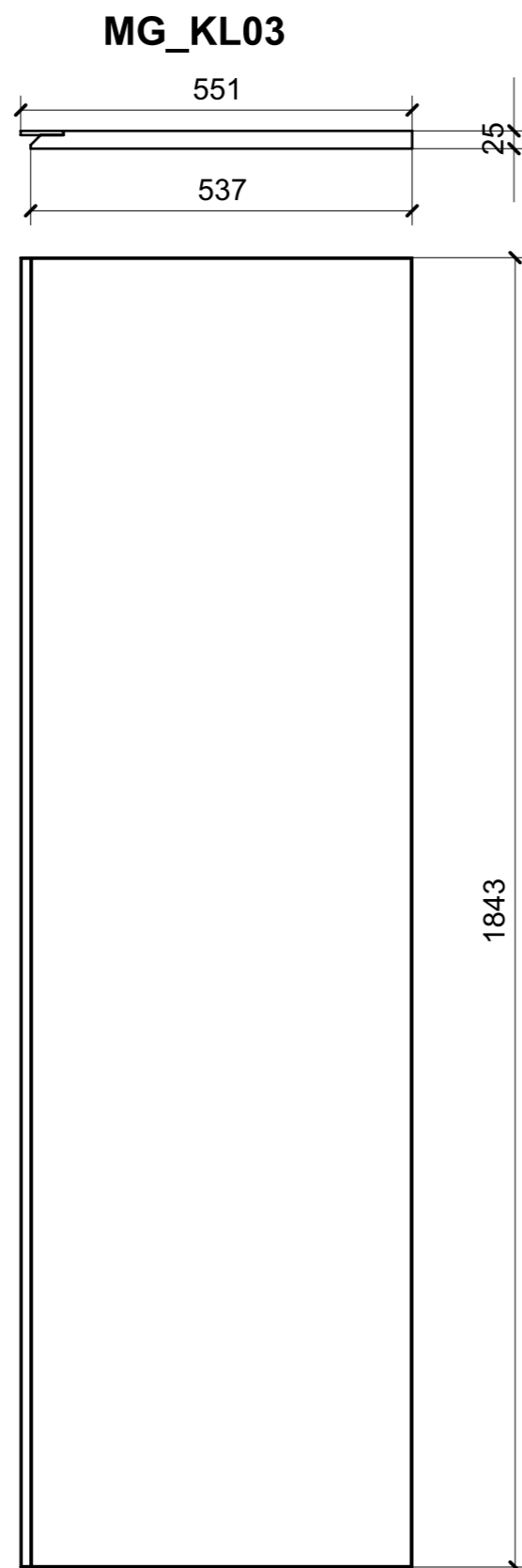
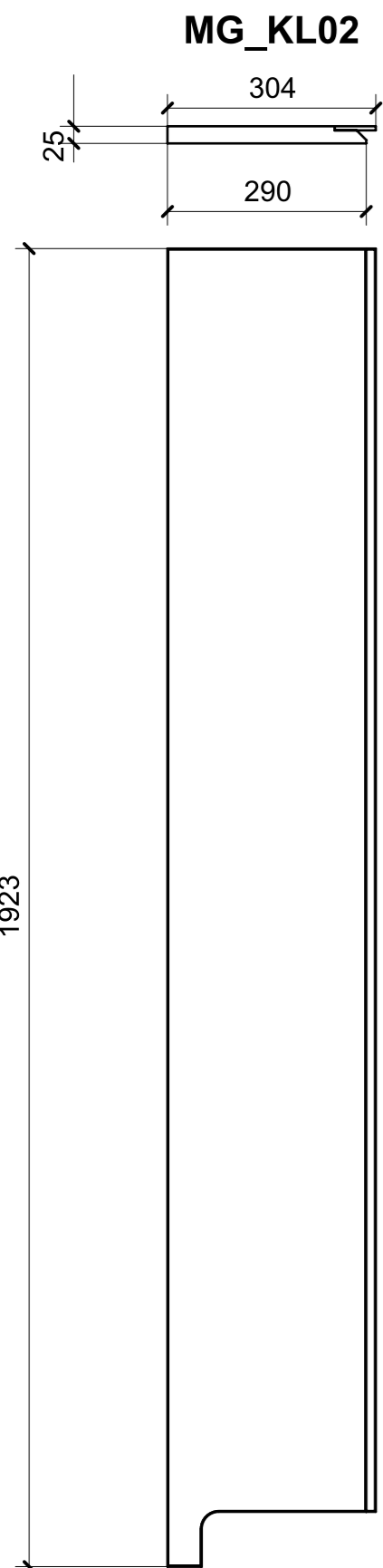

LOCALE	CODICE	DESCRIZIONE COMPONENTE	FINITURA	GR.
CUCINA	MD320_MG_KN01	PLENUM MOBILE BICCHIERI		PTP

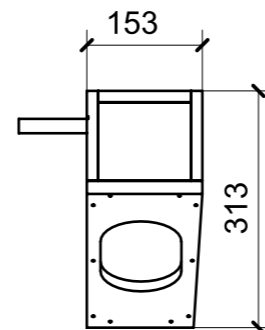
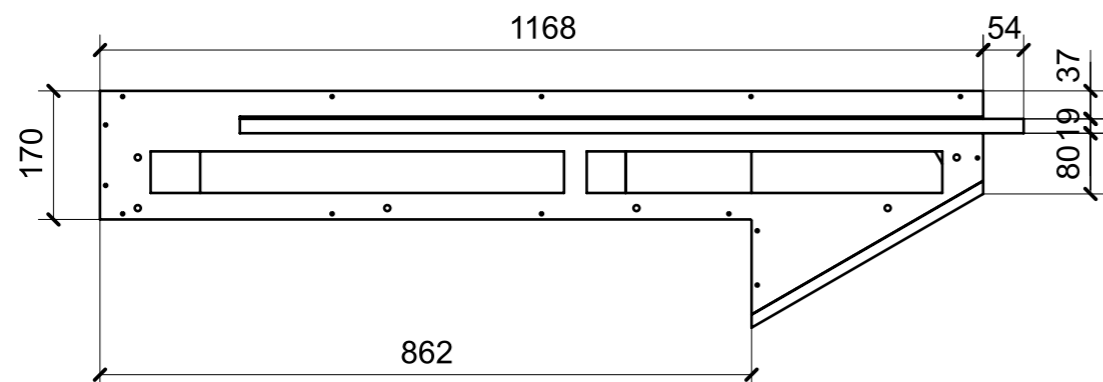
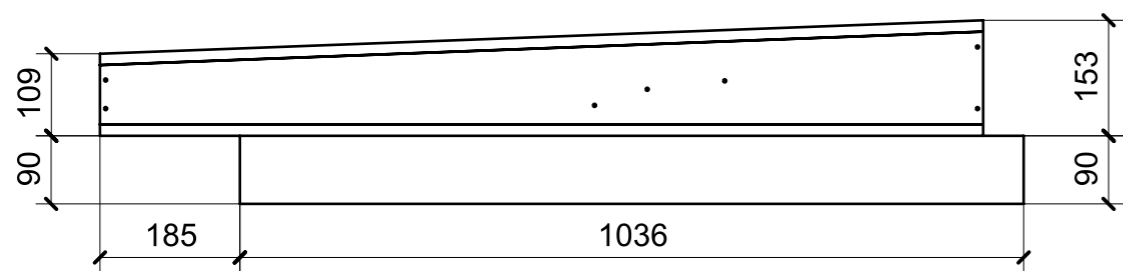
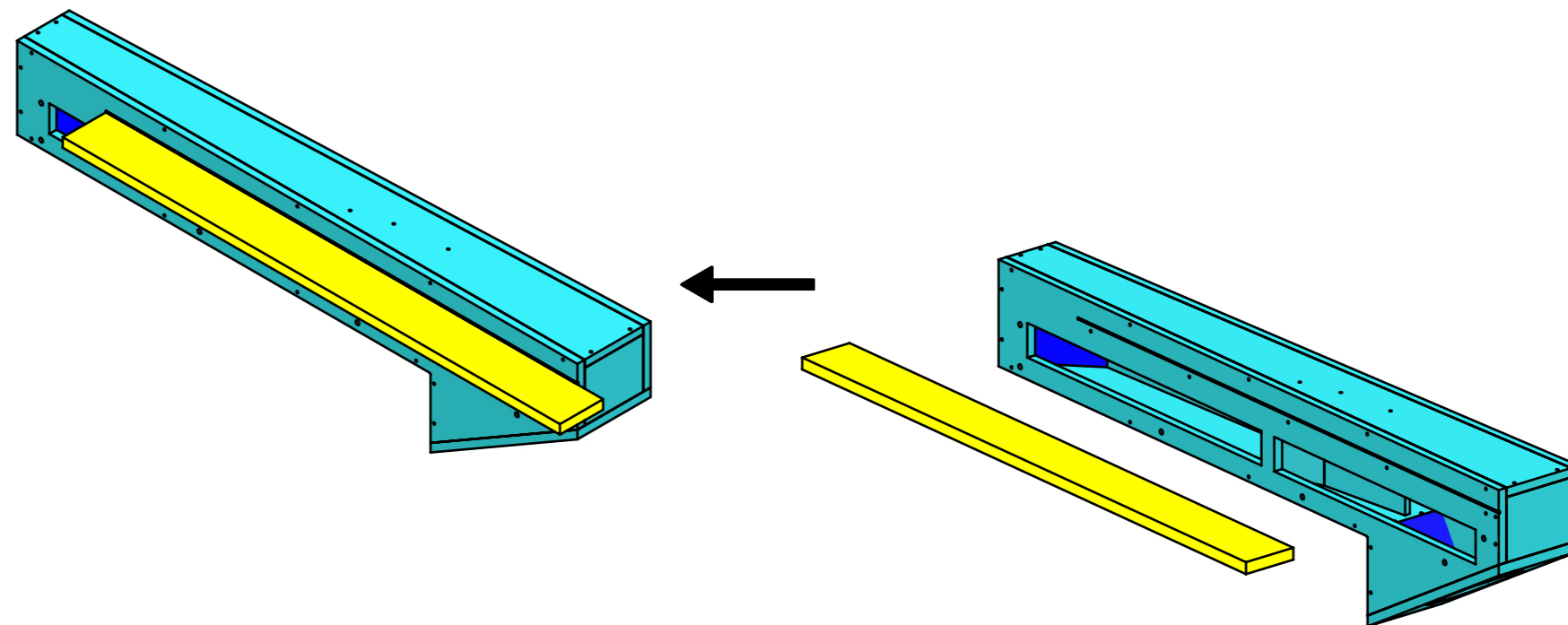

FERRAMENTA	QTY
BUSSOLA 6MA X 10 FORO DIAM.8	3

LOCALE	CODICE	DESCRIZIONE COMPONENTE	FINITURA	GR.
CUCINA	MD320_MG_KO01/02	CASSA FRIGO AGGIUNTIVO		2

### MG\_KO01

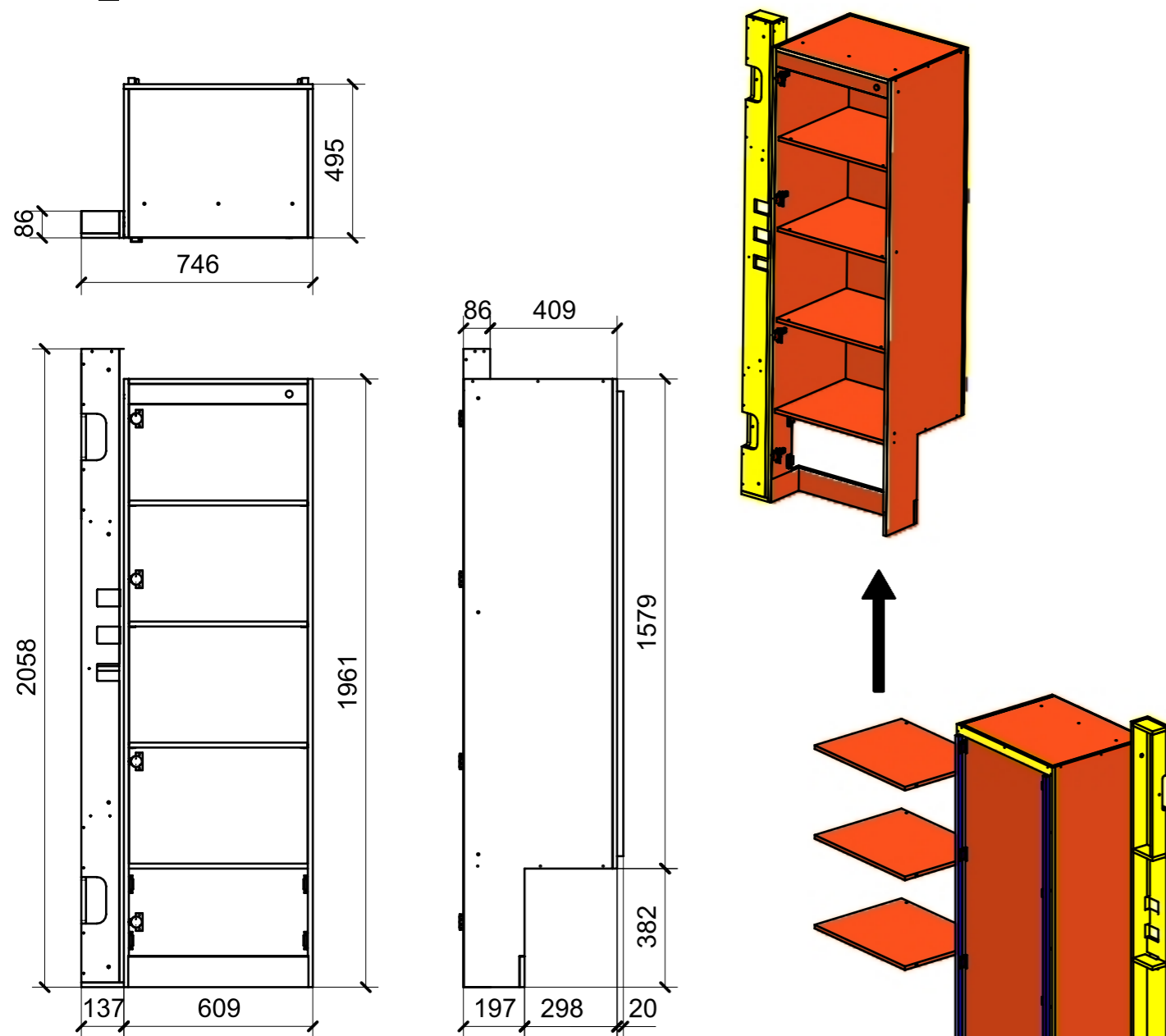

FERRAMENTA	QTY
PERNO LISCIO PER SPALLA_ FBC BORGHI_1033PXX050531	12
GIUNTO REGGIRIPIANO CON BORDO ANTISGANCIO_FBC BORGHI_1033XXB060902	12
VITE 6MA X 25 TESTA BOMBATA	2
CERNIERA 95°_COLLO PIENO-NERA_HAFELE_342.46.606-BLUM_71B9750.STP	4
VITE 6MA X 25 TESTA BOMBATA NERA BHCS 10.9 ISO 7380	3
BASE_0-NERA_HAFELE_342.22.065-BLUM_175H3100.STP	4
VITE 4MAX8 ANKOR BORGHI X BASE 0	8
BUSSOLA 5MA ANKOR BORGHI X BASE 0	8
BUSSOLA 6MA X 10 FORO DIAM.8	8
CHIUSURA A SPINTA_TECHNOPARTNER_SOU C3-203	12
GIUNTO REGGIRIPIANO_HAFELE_262.36.510	12
MAGNETE FORZA MAGNETICA1-5 10KG_HAFELE_246.87.112	1

### MG\_KO02

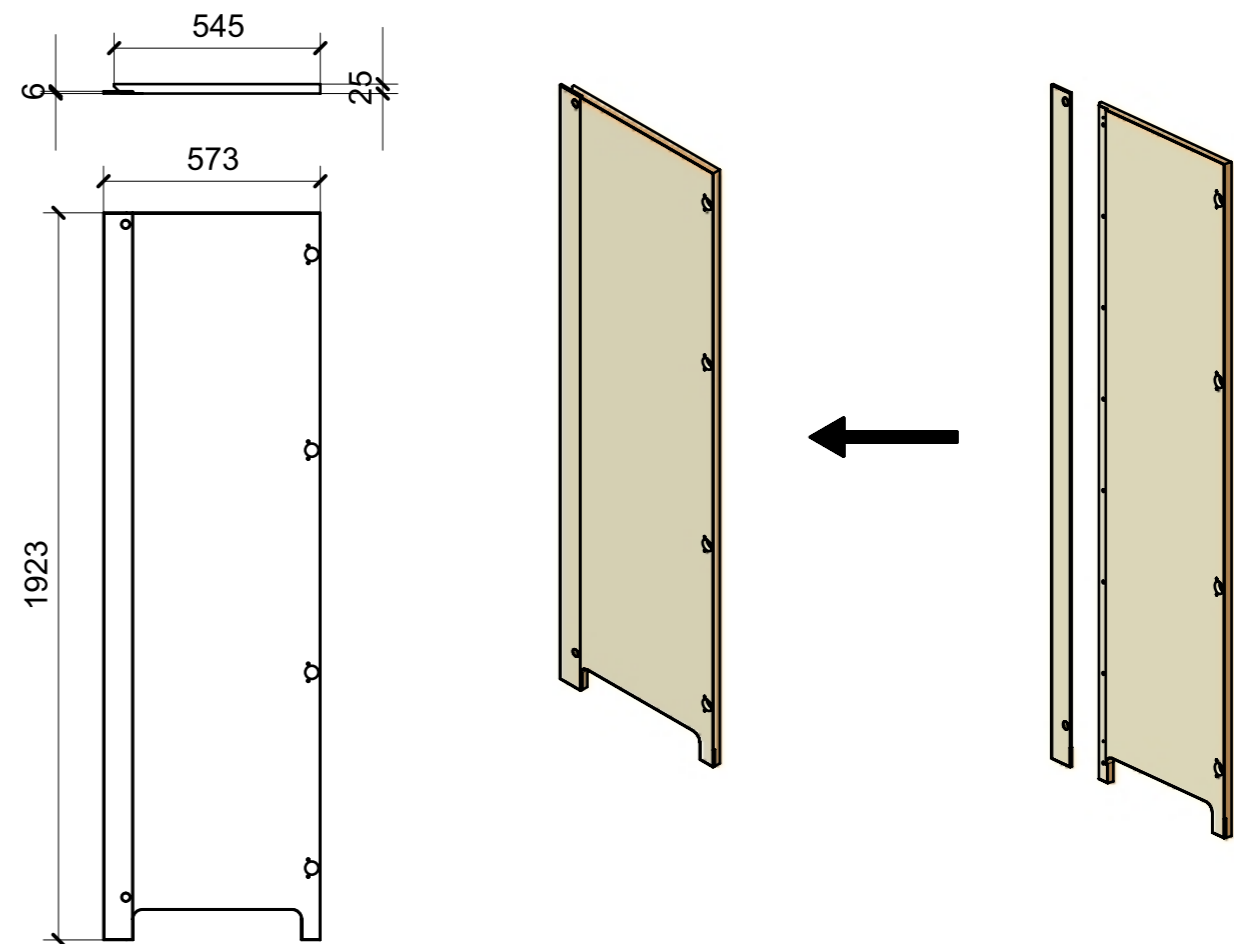

FERRAMENTA	QTY
MAGNETE FORZA MAGNETICA1-5 10KG_HAFELE_246.87.112	2
BUSSOLA 5MA ANKOR BORGHI X CERNIERA COLLO PIENO	8

LOCALE	CODICE	DESCRIZIONE COMPONENTE	FINITURA	GR.
CUCINA	MD320_MG_KP01	CASSA RICIRCOLO ARIA FRIGO AGGIUNTO		PTP

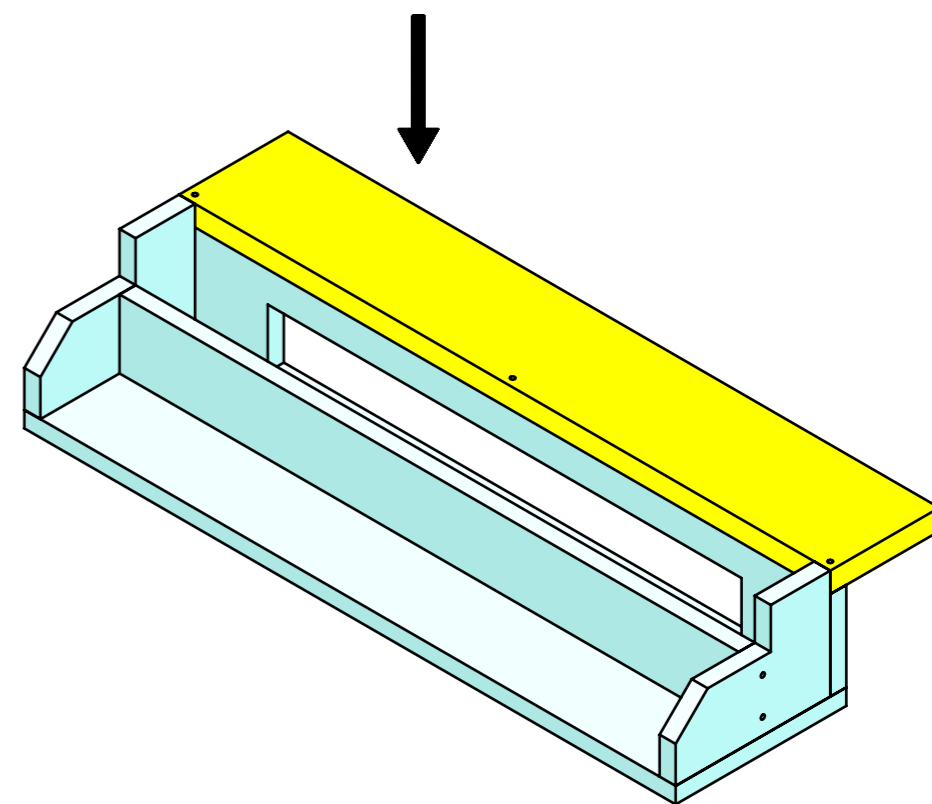
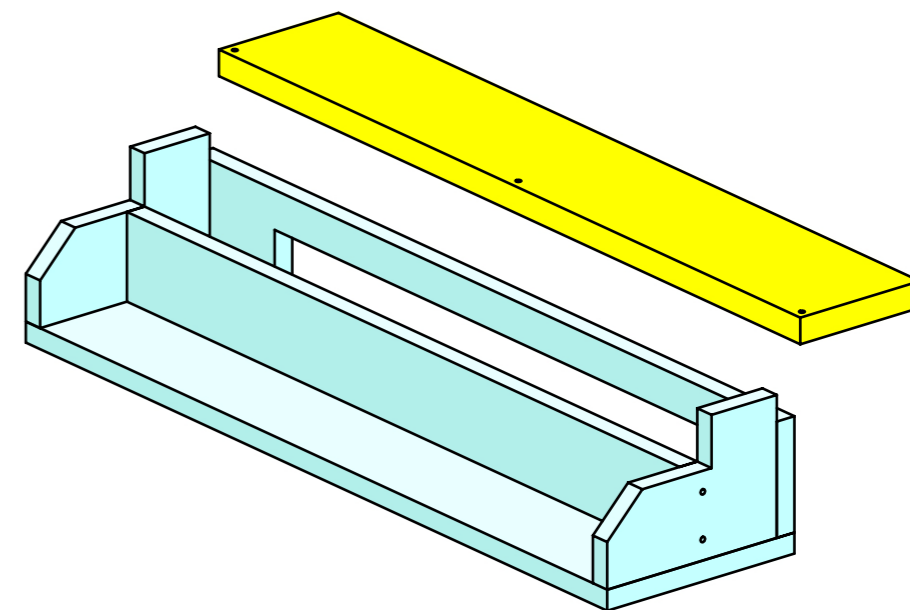
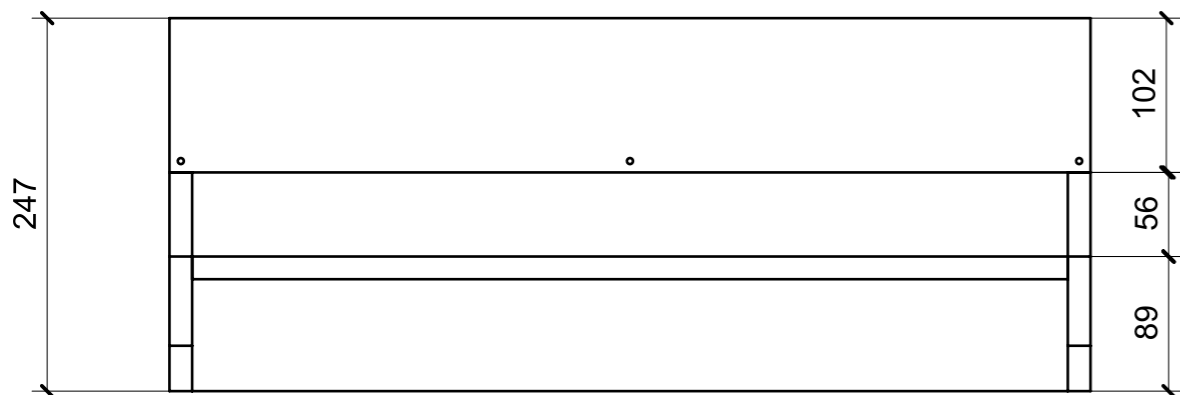
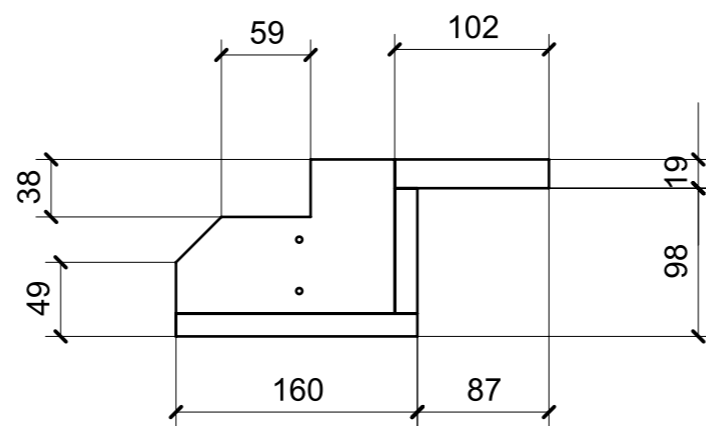
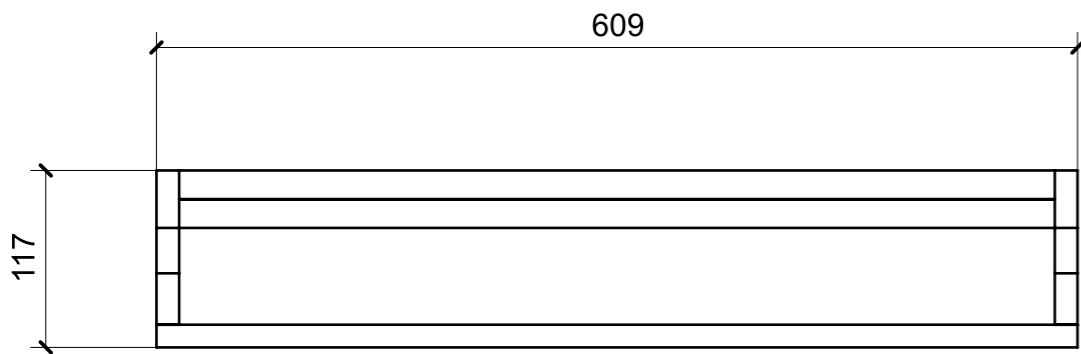

FERRAMENTA	QTY
BUSSOLA 6MA X 10 FORO DIAM.8	3