

LOCALE	CODICE	DESCRIZIONE COMPONENTE	FINITURA	GR.
CABINA VIP	MD320_MG_VB01	COMODINO PRUA		2

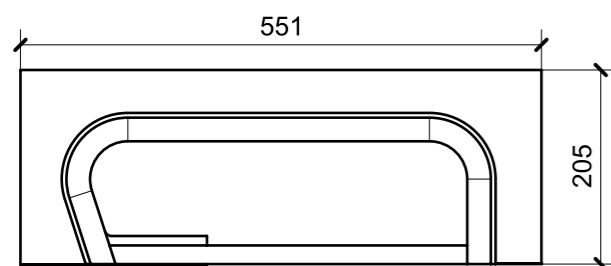

SECTION M-M

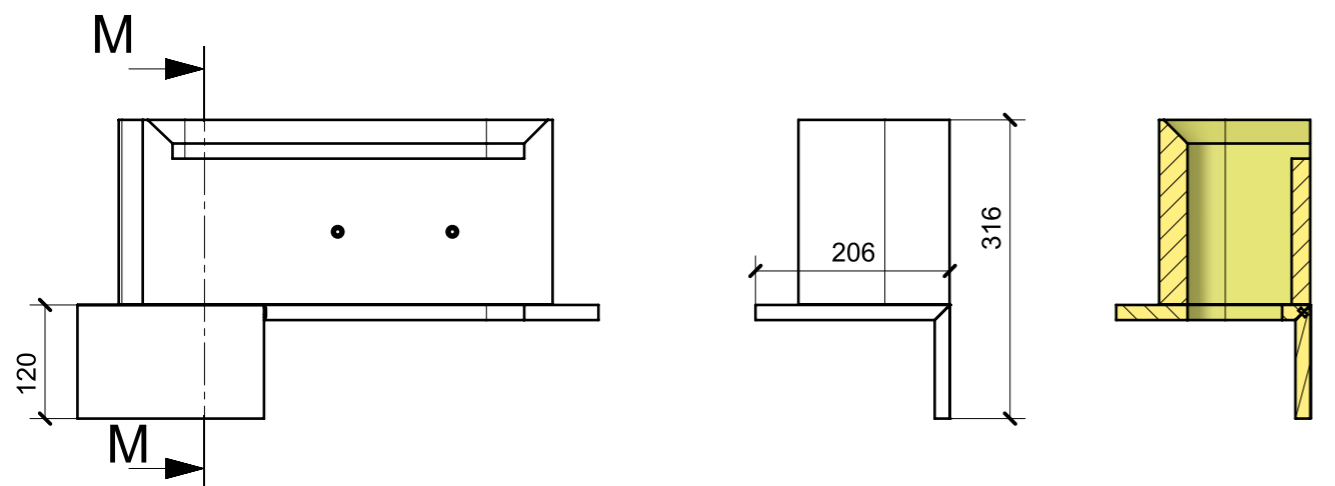
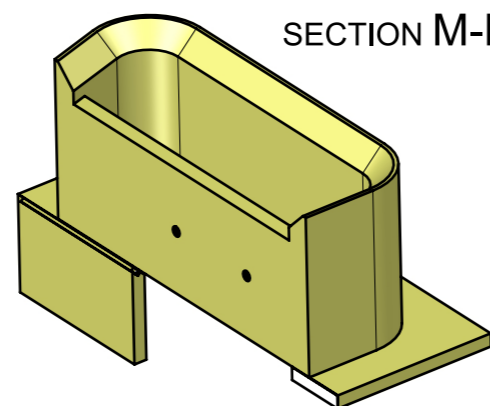

MG_VB01

FERRAMENTA	QTY
BUSSOLA 6MA X 10 FORO DIAM.8	2

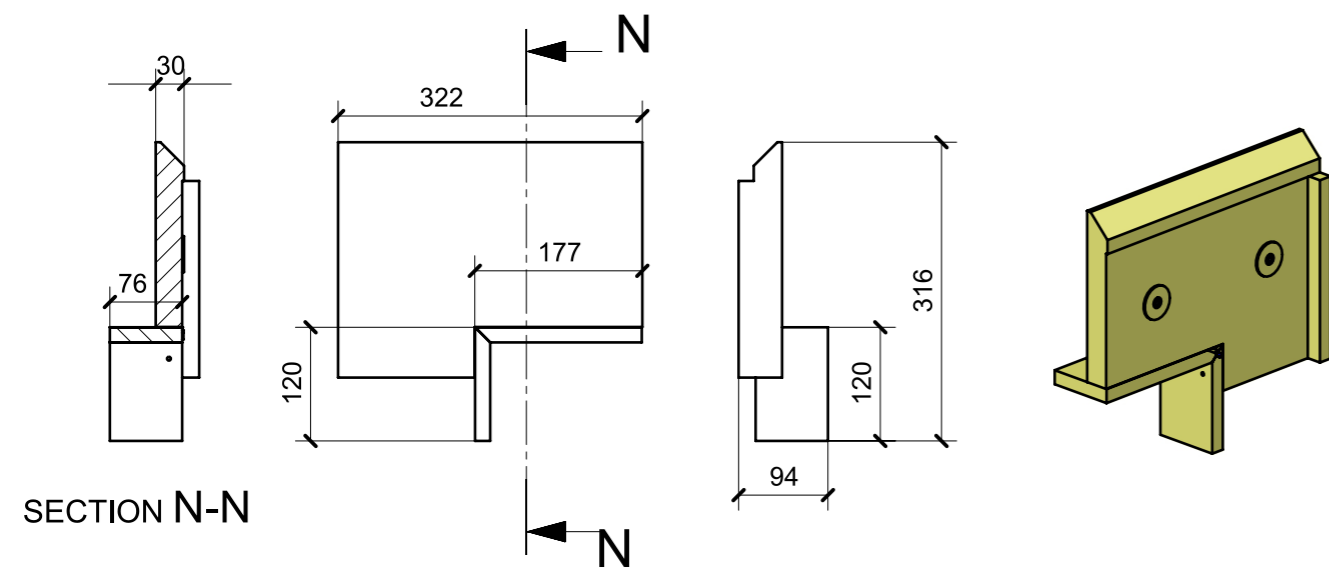
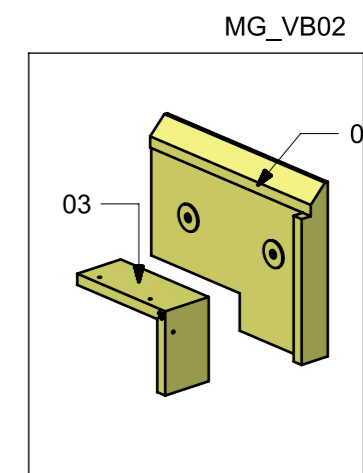
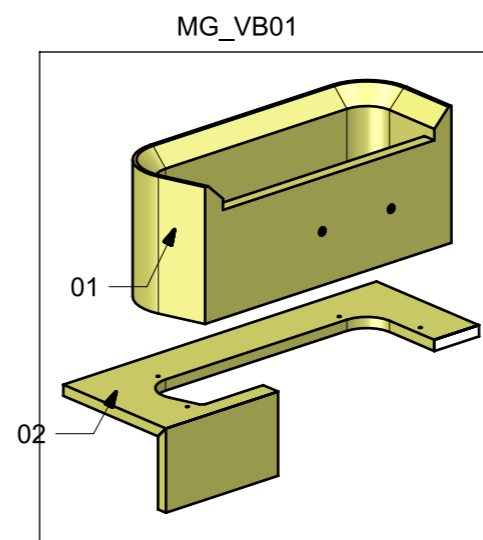

SECTION N-N

MG_VB02

FERRAMENTA	QTY
BUSSOLA 6MA X 10 FORO DIAM.8	2

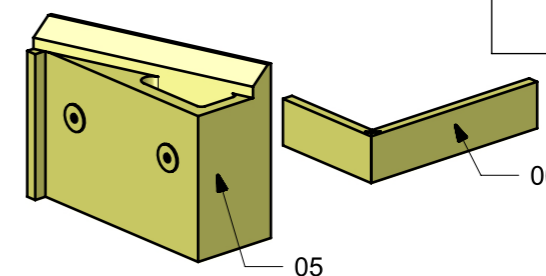

LOCALE	CODICE	DESCRIZIONE COMPONENTE	FINITURA	GR.
CABINA VIP	MD320_MG_VC01	STRUTTURA LETTO	OKUME' GREZZO/LAMINATO SMART 0180-2 JUNGLE	2

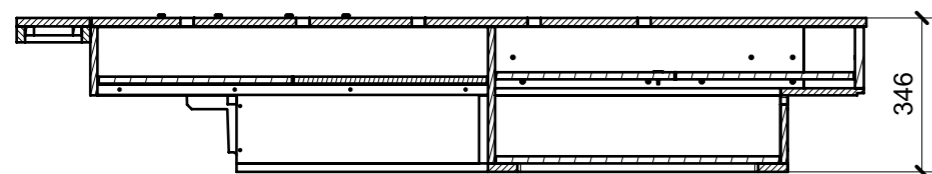

SECTION L-L

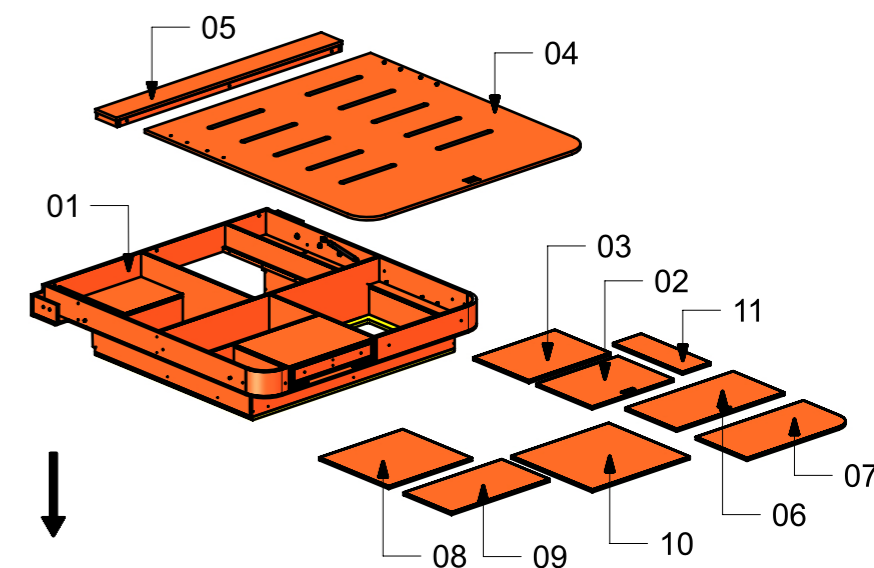
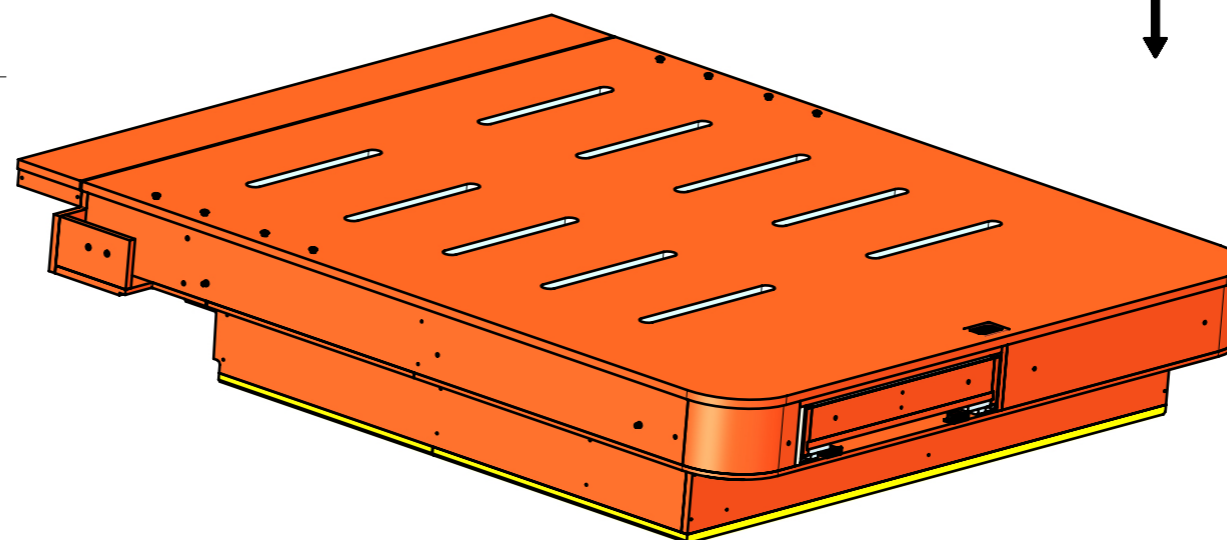
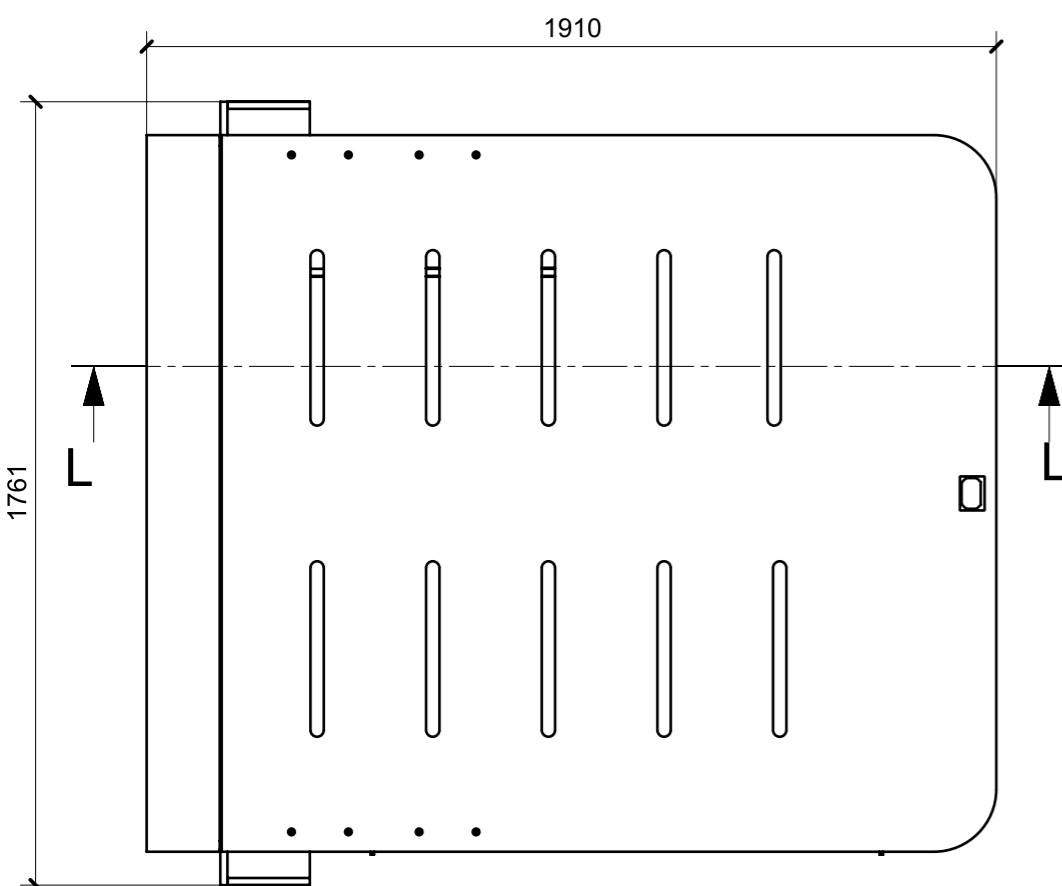

FERRAMENTA	QTY
ALZAPAGLIOLI_FORESTI_164.B BRUNITON	2
BORCHIA PASSO 6MA_FBC	8
BUSSOLA 6MA X 10 FORO DIAM.8	9
BUSSOLA 8MA X 14_FBC	8
BUSSOLA RAPIDA_FBC BORGHI_00280877	4
CALAMITA SEALED MAGNETIC_TECNOPARTNER_MC-JM50-BL	2
CP TRAPEZI NERI STABILUS TZ 530 BTZ T2.A0_FBC_99999049	1
GUIDA DYNAPRO ADJUSTMENT ADAPTER L_FBC_F134141746 4D	1
GUIDA DYNAPRO ADJUSTMENT ADAPTER R_FBC_F134141746 4D	1
GUIDA DYNAPRO FRONT LOCKING DEVICE L_FBC_F134108955 4D	1
GUIDA DYNAPRO FRONT LOCKING DEVICE R_FBC_F134108955 4D	1
GUIDA DYNAPRO SOFTCLOSE L400 L_FBC_F130107808 4D	1
GUIDA DYNAPRO SOFTCLOSE L400 R_FBC_F130107808 4D	1
MANIGLIETTA ALZA LETTO_FORESTI_ART.76A.C	1
PISTONE A GAS STABILUS_456306_600NW-L385_FBC	1
PISTONE A GAS STABILUS_456306_600NW-L385_FBC_99999049	1
PLACCHETTA COUNTER STEEL_TECNOPARTNER_MC-JM49	2
RANELLA SP.2 MM DIAM.24 FORO 8_FBC	8
REGGIRIPIANO PERNO RAPIDO X CR. CO-RING_FBC BORGHI_00073653	12
SEEGER PER MECC. LETTO_00407908	2
TBL 6MAX15_FBC	8
TBL 8MA X 20_FBC	8
VITE 6MA X 25 TESTA BOMBATA NERA BHCS 10.9 ISO 7380	3

LOCALE	CODICE	DESCRIZIONE COMPONENTE	FINITURA	GR.
CABINA VIP	MD320_MG_VD01	COMODINO POPPA	LACCATO BRONZO SPAZZOLATO	2

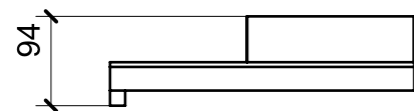
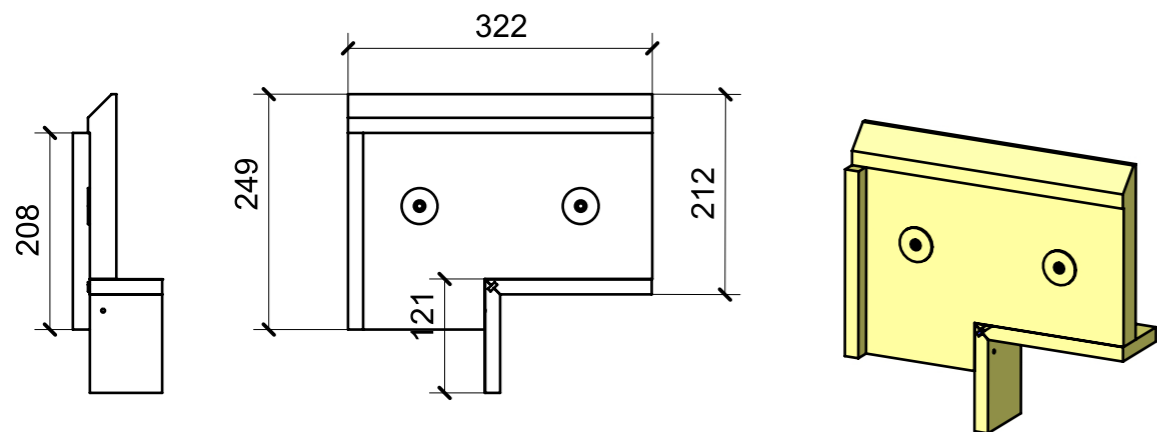

MG_VD02

FERRAMENTA	QTY
BUSSOLA 6MA X 10 FORO DIAM.8	2

MG_VD01

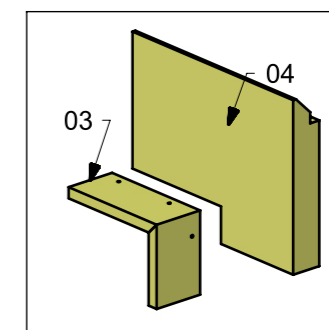
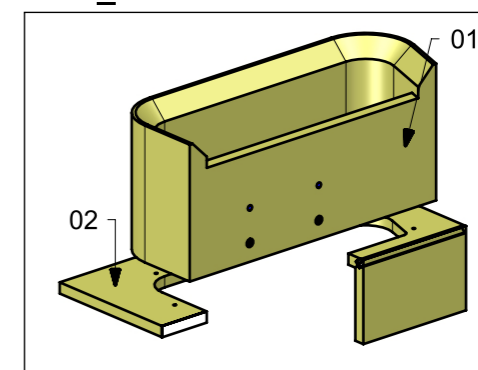

MG_VD02

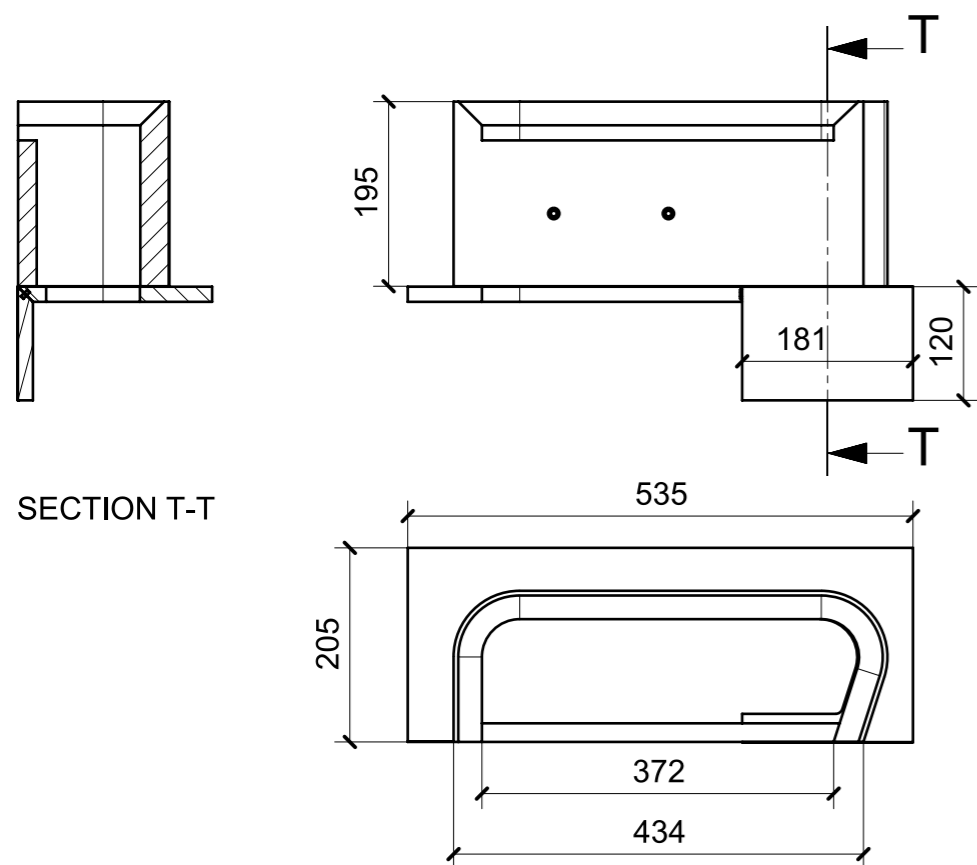

MG_VD01

FERRAMENTA	QTY
BUSSOLA 6MA X 10 FORO DIAM.8	2

LOCALE	CODICE	DESCRIZIONE COMPONENTE	FINITURA	GR.
CABINA VIP DX	MD320_MG_VI01	ARMADIO		2

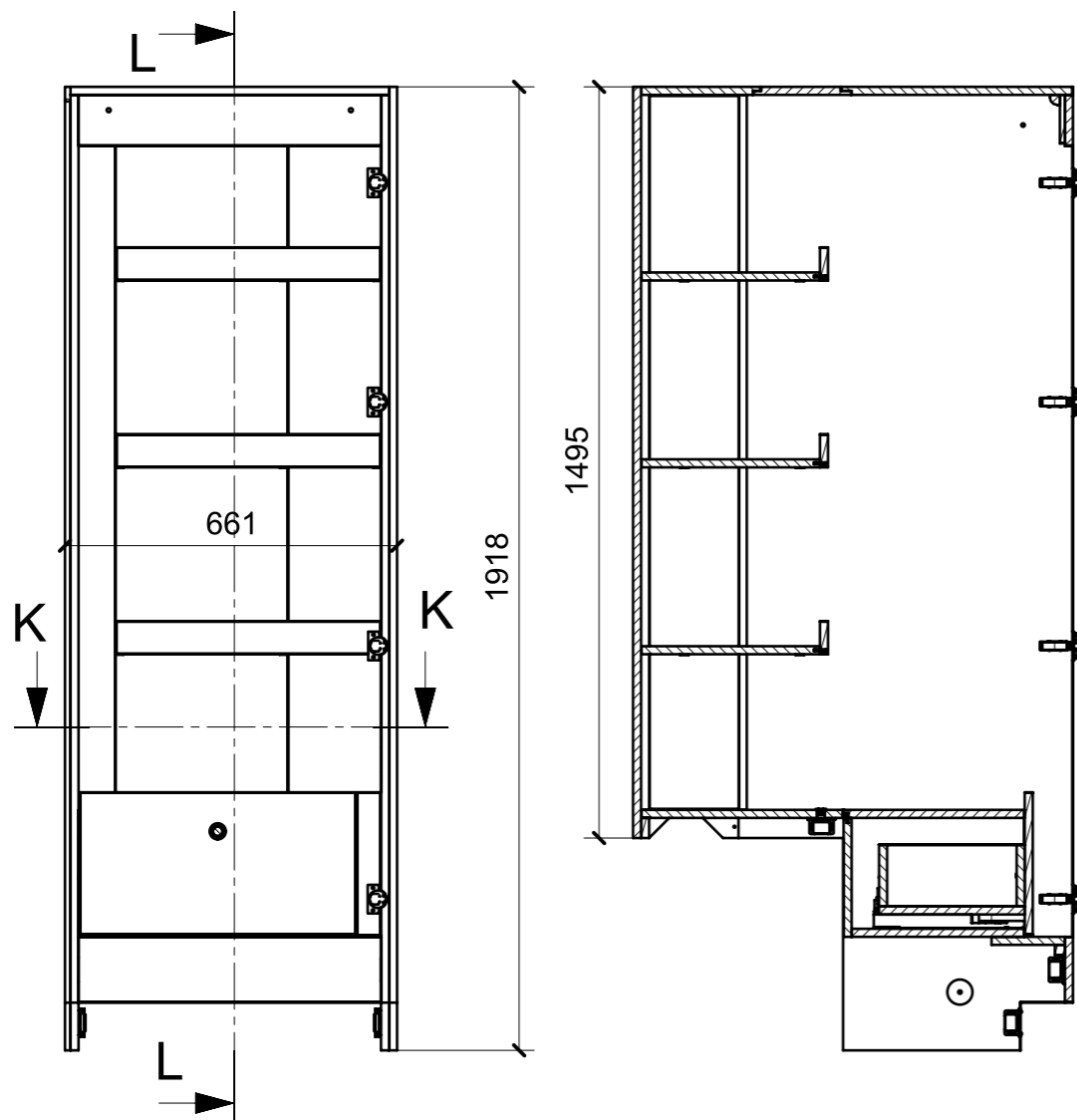

SECTION L-L

SECTION K-K

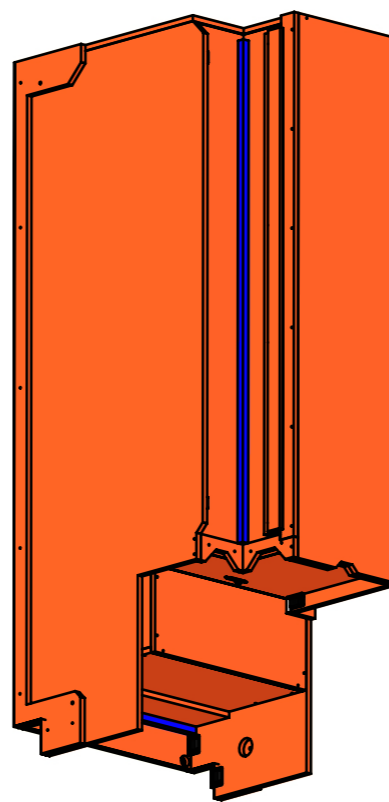
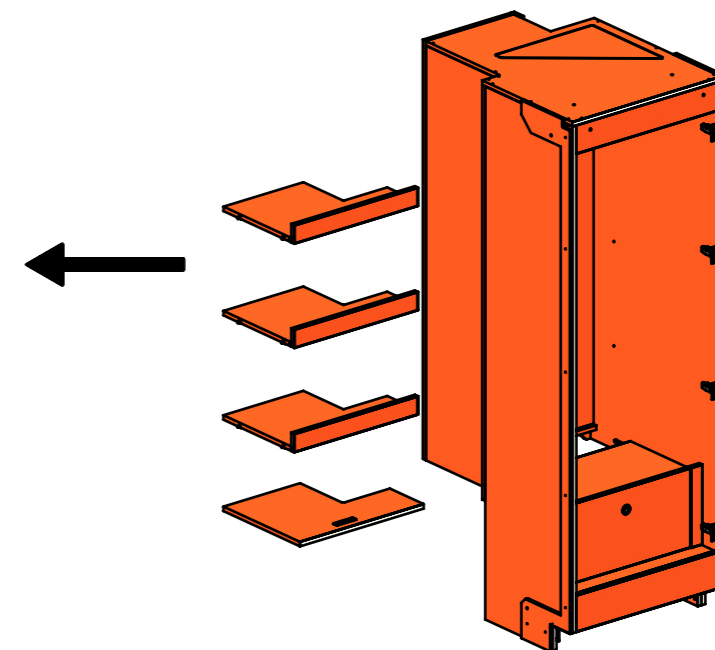
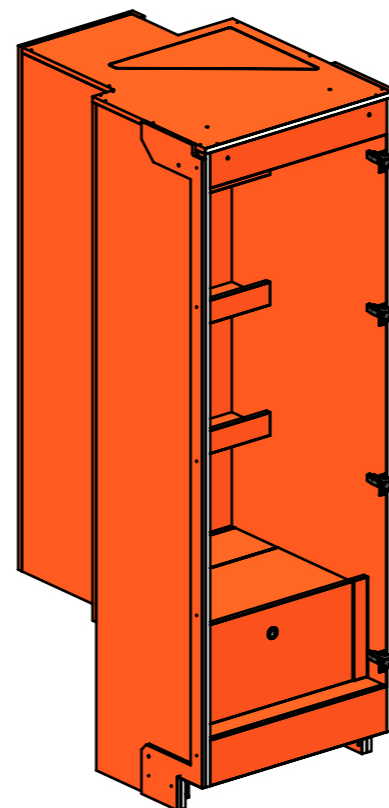

FERRAMENTA	QTY
GUIDA DYNAPRO FRONT LOCKING DEVICE L_FBC_F134108955 4D	1
GUIDA DYNAPRO SOFTCLOSE L300 L_FBC_F130107796 4D	1
GUIDA DYNAPRO ADJUSTMENT ADAPTER L_FBC_F134141746 4D	1
GUIDA DYNAPRO FRONT LOCKING DEVICE R_FBC_F134108955 4D	1
GUIDA DYNAPRO SOFTCLOSE L300 R_FBC_F130107796 4D	1
GUIDA DYNAPRO ADJUSTMENT ADAPTER R_FBC_F134141746 4D	1
KIT LED PER ARMADIO MD320 VI01-VVI01 MM 600_	1
PERNO LISCIO PER SPALLA_FBC BORGHI_1033PXX050531	24
GIUNTO REGGIRIPIANO CON BORDO ANTISGANCIO_FBC BORGHI_1033XXB060902	24
COPERTURA BRACCIO CERNIERA NERO-HAFELE_342.94.602-BLUM_70.1503.STP	4
CERNIERA 94°_PIANA-NERA_HAFELE_342.46.604-BLUM_71B9550.STP	4
BUSSOLA 5MA ANKOR BORGHI X CERNIERA PIANA	8
PUSH TO CLOSE_SOUTHCO-MP-05-312-55 NERA_TECHNOPARTNER	1
VITE 4MA X 12 TESTA SVASATA ESAGONALE NERA_FBC	2
KEEPER PUSH TO CLOSE_SOUTCHO-J-M1-519-4_TECHNOPARTNER	1
VITE 6MA X 25 TESTA BOMBATA NERA BHCS 10.9 ISO 7380	12
VITE 4MAX8 ANKOR BORGHI X BASE 0	8
ALZAPAGLIOLI_FORESTI_164.B BRUNITON	1
BASE_0-NERA_HAFELE_342.22.065-BLUM_175H3100.STP	4
BUSSOLA 6MA X 10 FORO DIAM.8	10
CHIUSURA A SPINTA_TECHNOPARTNER_SOU C3-203	8
MAGNETE FORZA MAGNETICA1-5 10KG_HAFELE_246.87.112	2

LOCALE	CODICE	DESCRIZIONE COMPONENTE	FINITURA	GR.
CABINA VIP	MD320_MG_VL01	PLENUM ARMADIO		2

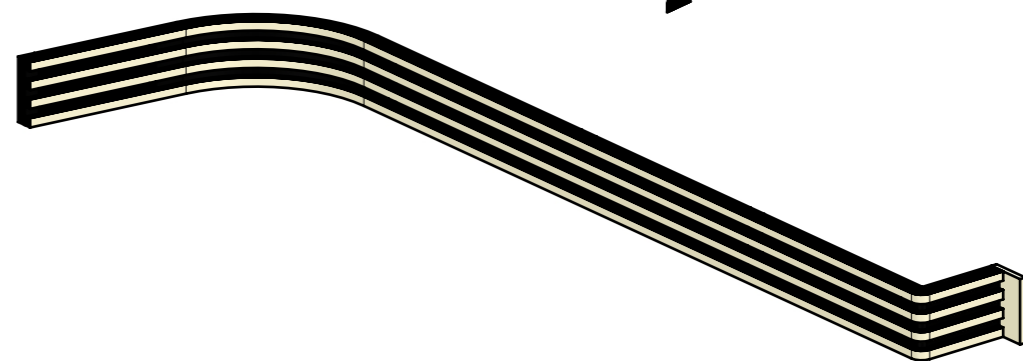
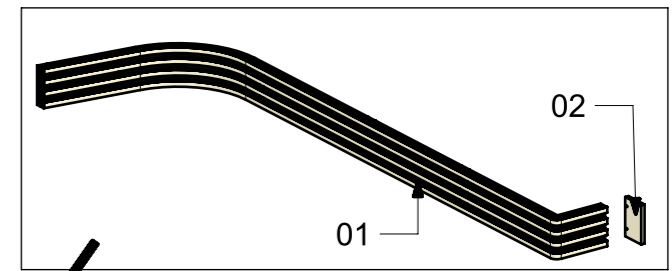
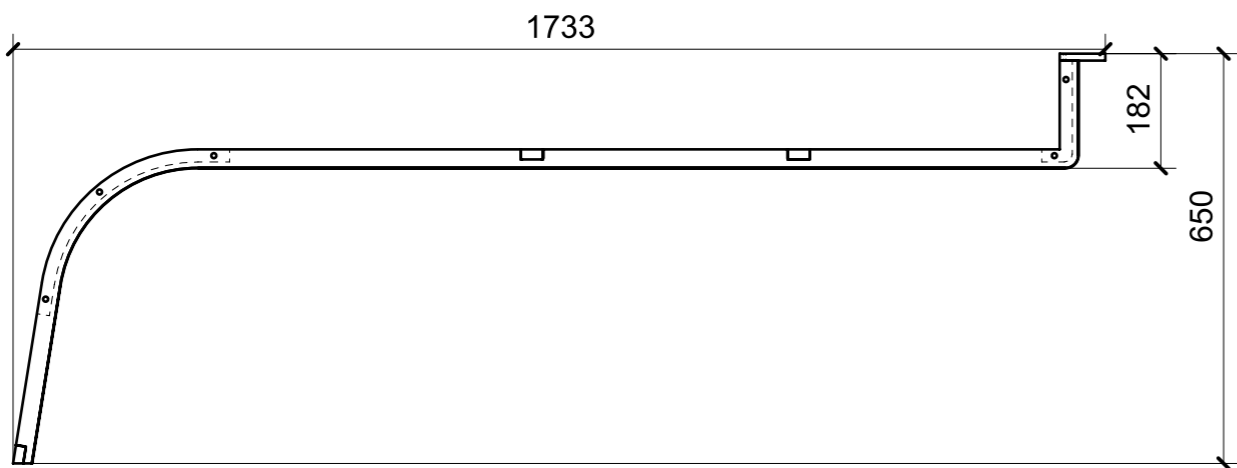
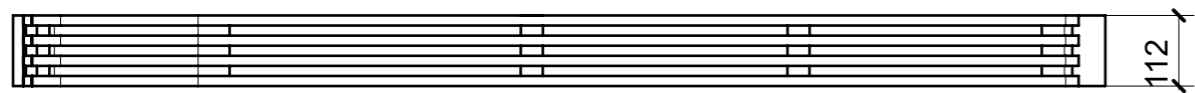

MG_VL01

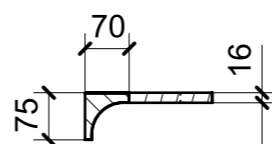
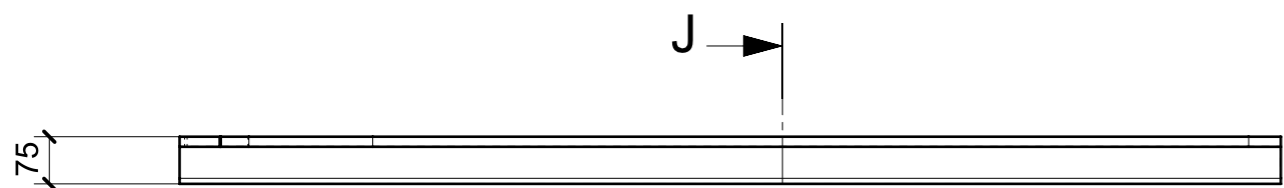

SECTION J-J

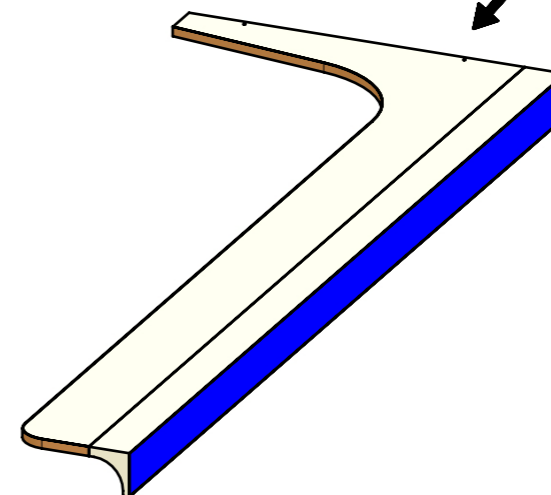
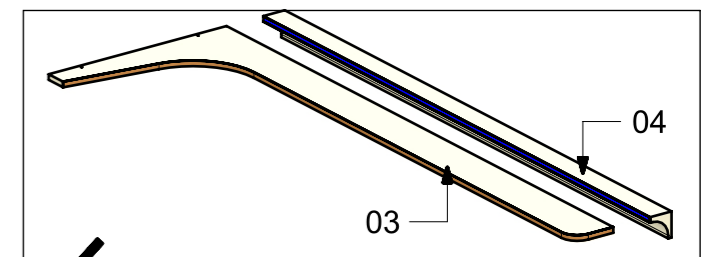
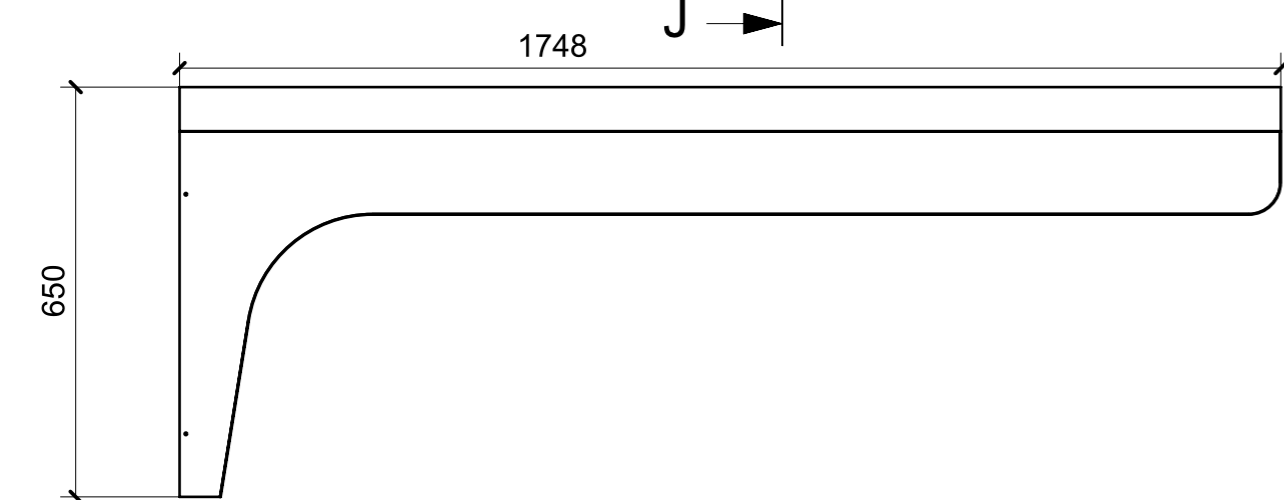

MG_VL02