

LOCALE	CODICE	DESCRIZIONE COMPONENTE	FINITURA	GR.
LOBBY MD	MD320_R02_CCA01	STRUT. LATO SX MOBILE RACK	LASTRA CHIARA	3

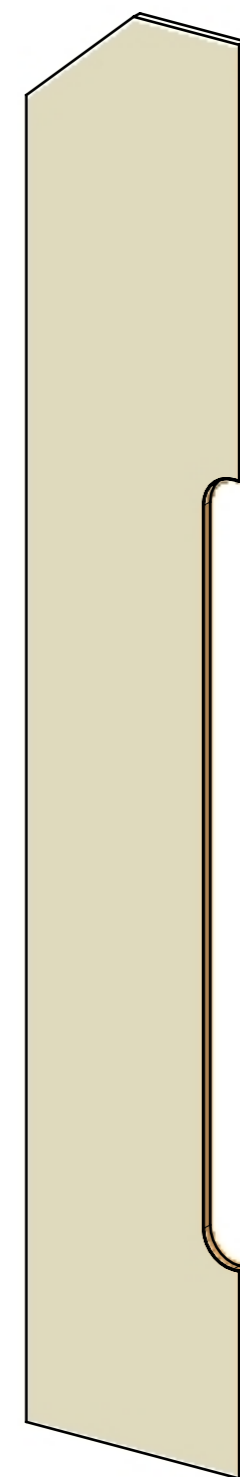
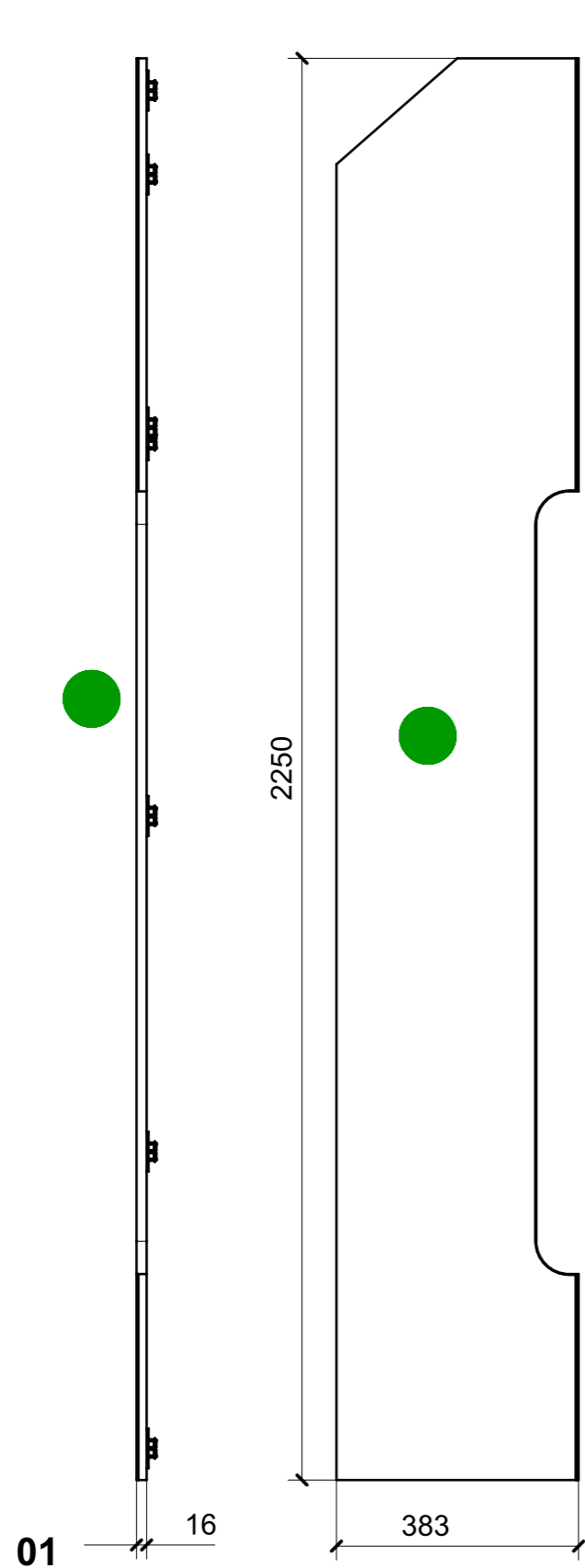

FERRAMENTA	QTY
FITLOCK M_MASCHERPA_3MM_6020202101	10

VERNICIATURA LASTRA/LACCATI:

● = VERNICIARE 1 LATO + FILI RASATI O BORDATI

NESSUN SIMBOLO = VERNICIARE 2 LATI + FILI RASATI O BORDATI

LOCALE	CODICE	DESCRIZIONE COMPONENTE	FINITURA	GR.
LOBBY MD	MD320_R02_CCB01	MOBILE RACK	LASTRA CHIARA	2

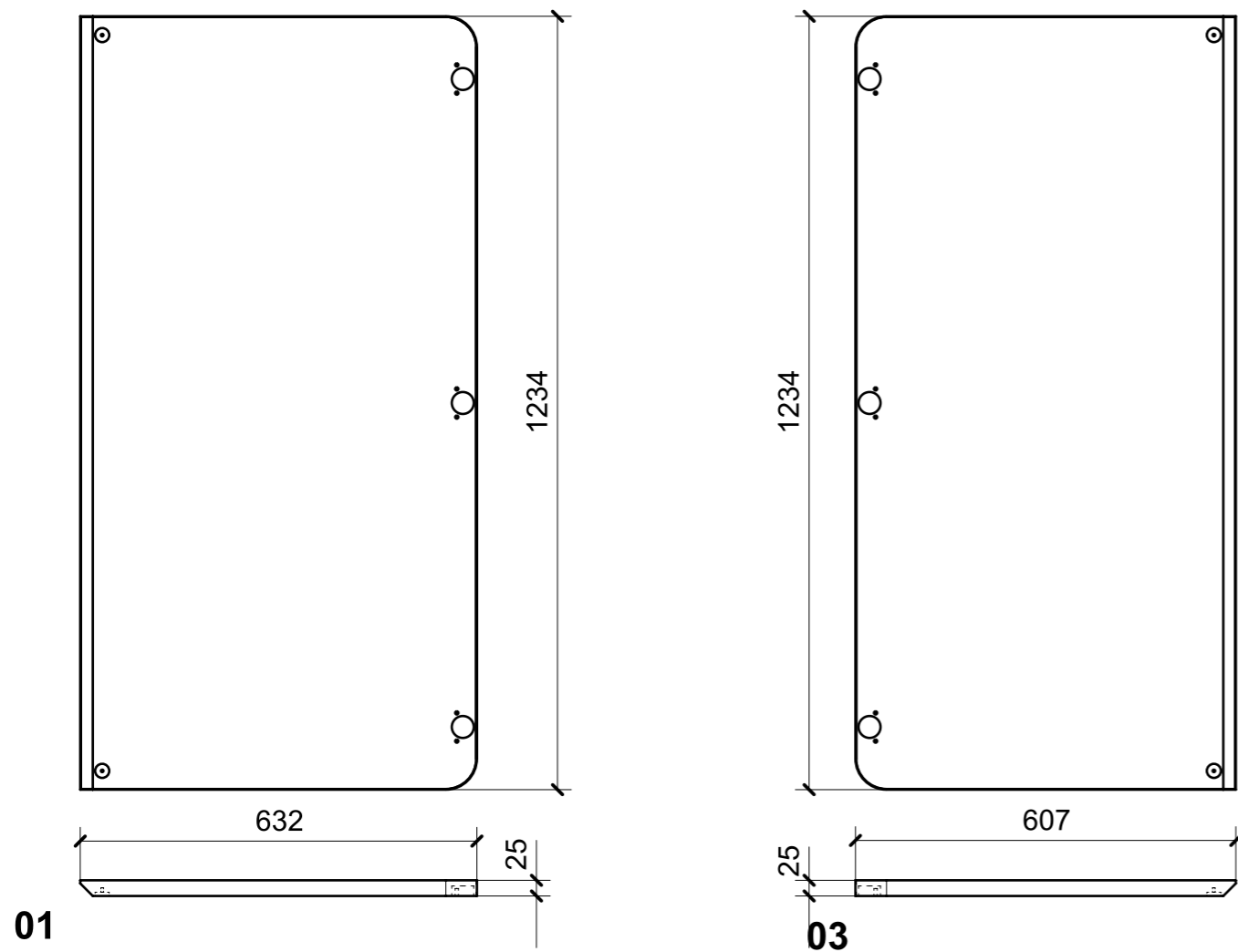

01

03

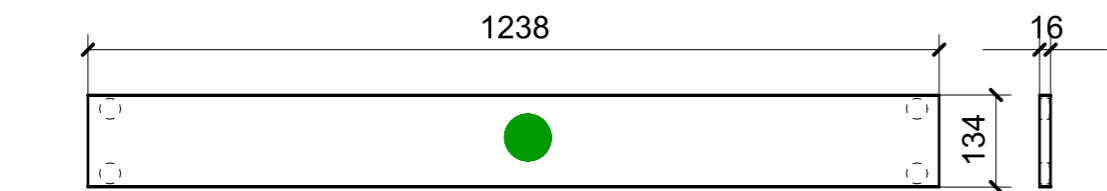
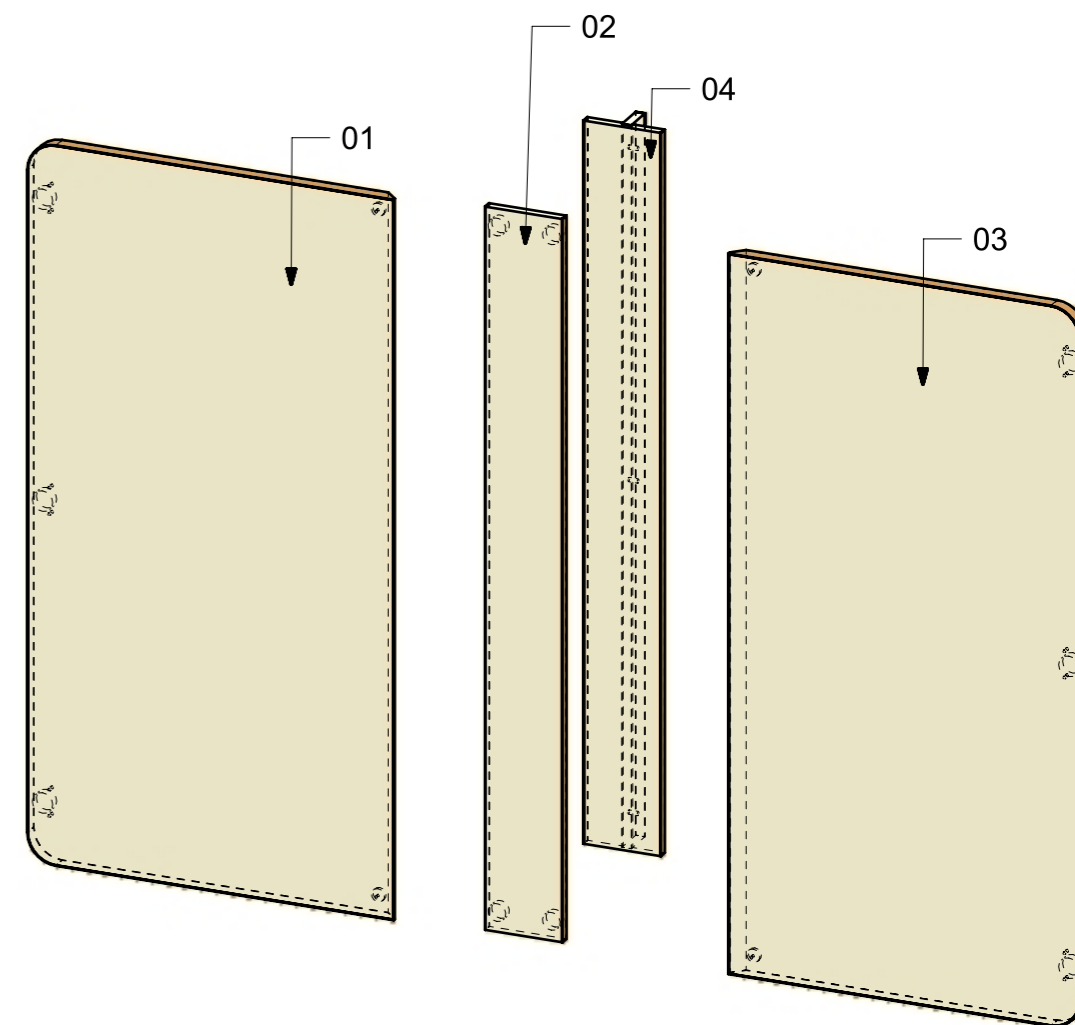

02

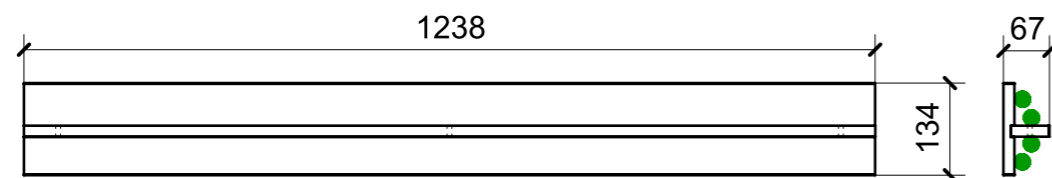

04

FERRAMENTA	QTY
MAGNETE FORZA MAGNETICA1-5 10KG_HAFELE_246.87.112	4
BUSSOLA 5MA ANKOR BORGHIS X CERNIERA COLLO PIENO	12

VERNICIATURA LASTRA/LACCATI:

● = VERNICIARE 1 LATO + FILI RASATI O BORDATI

NESSUN SIMBOLO = VERNICIARE 2 LATI + FILI RASATI O BORDATI

LOCALE	CODICE	DESCRIZIONE COMPONENTE	FINITURA	GR.
LOBBY MD	MD320_R02_CCC01	ZOCCOLO MOBILE RACK	LASTRA CHIARA	PTP

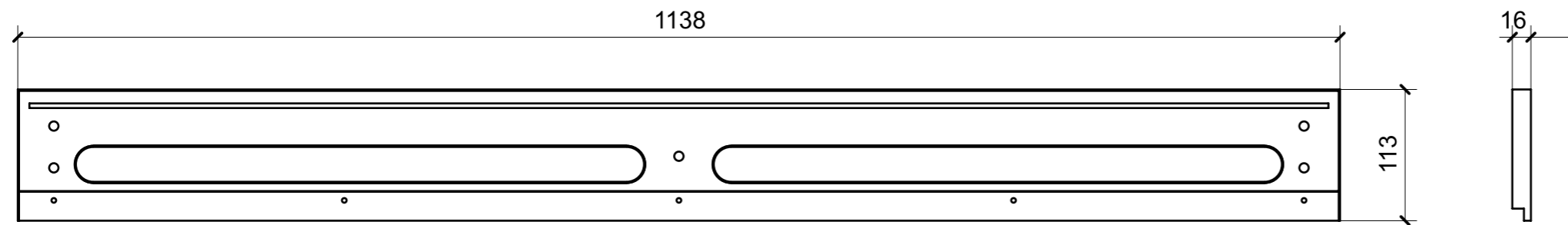

01

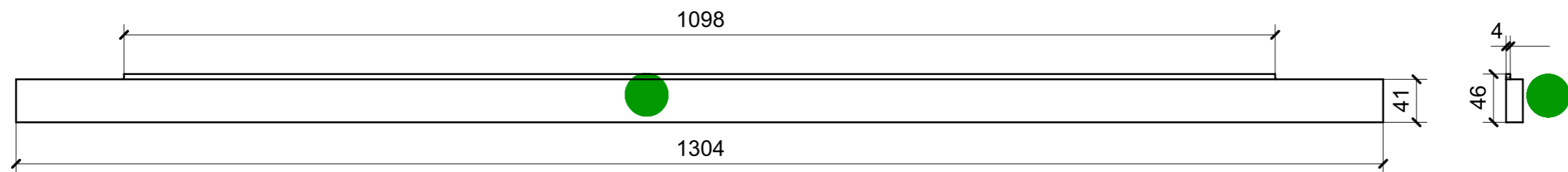

03

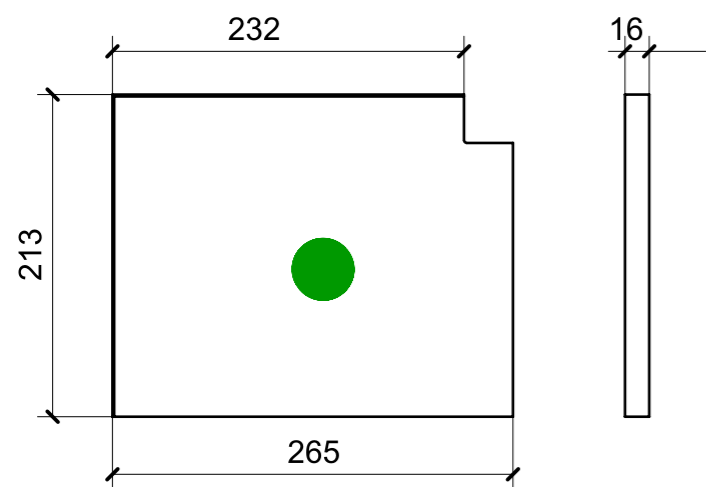

02

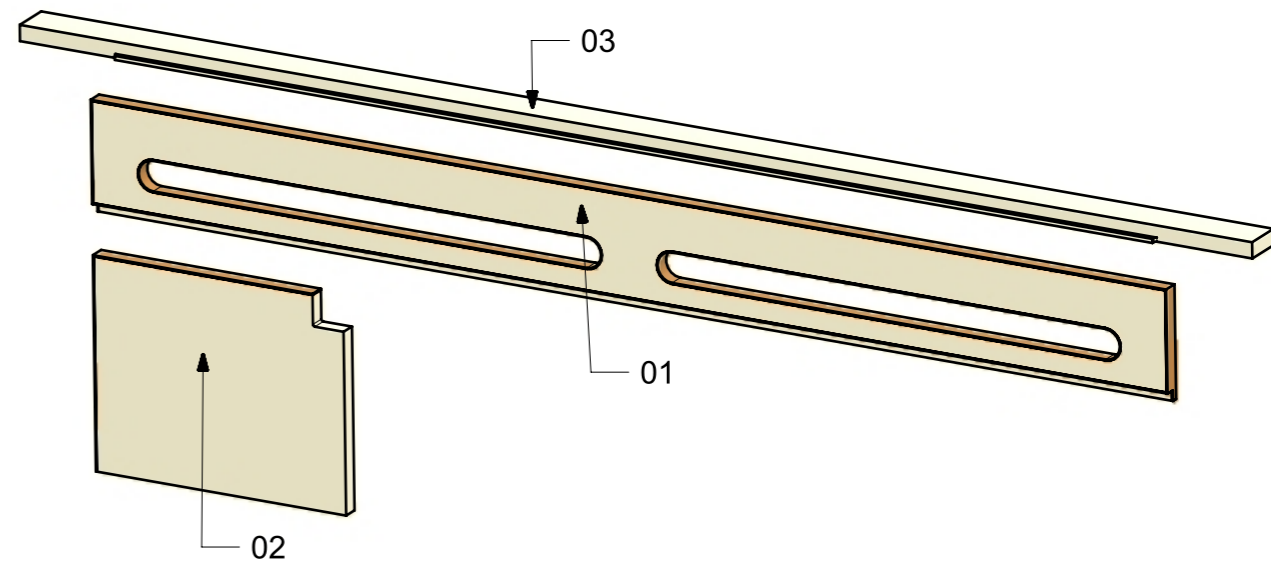

VERNICIATURA LASTRA/LACCATI:

● = VERNICIARE 1 LATO + FILI RASATI O BORDATI

NESSUN SIMBOLO = VERNICIARE 2 LATI + FILI RASATI O BORDATI

LOCALE	CODICE	DESCRIZIONE COMPONENTE	FINITURA	GR.
LOBBY MD	MD320_R02_CCD01	STRUTTURA SUPERIORE MOBILE RACK	LAISTRA CHIARA	2

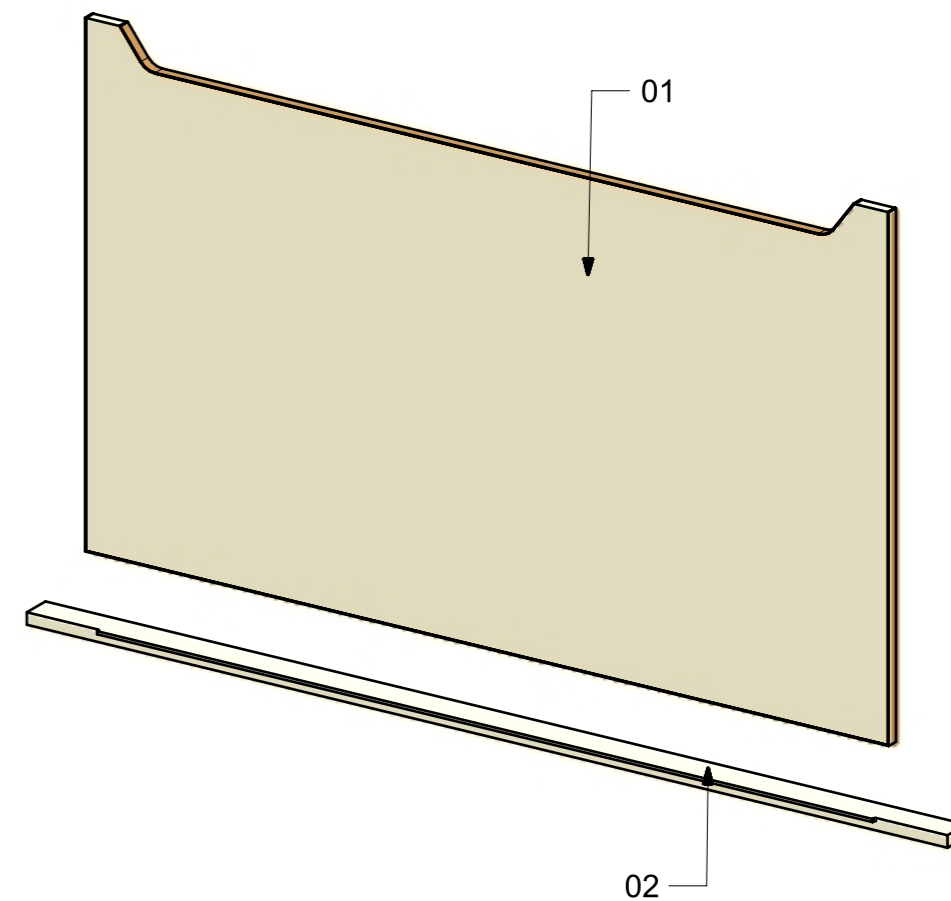
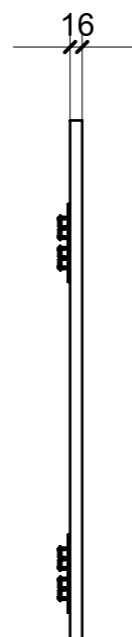
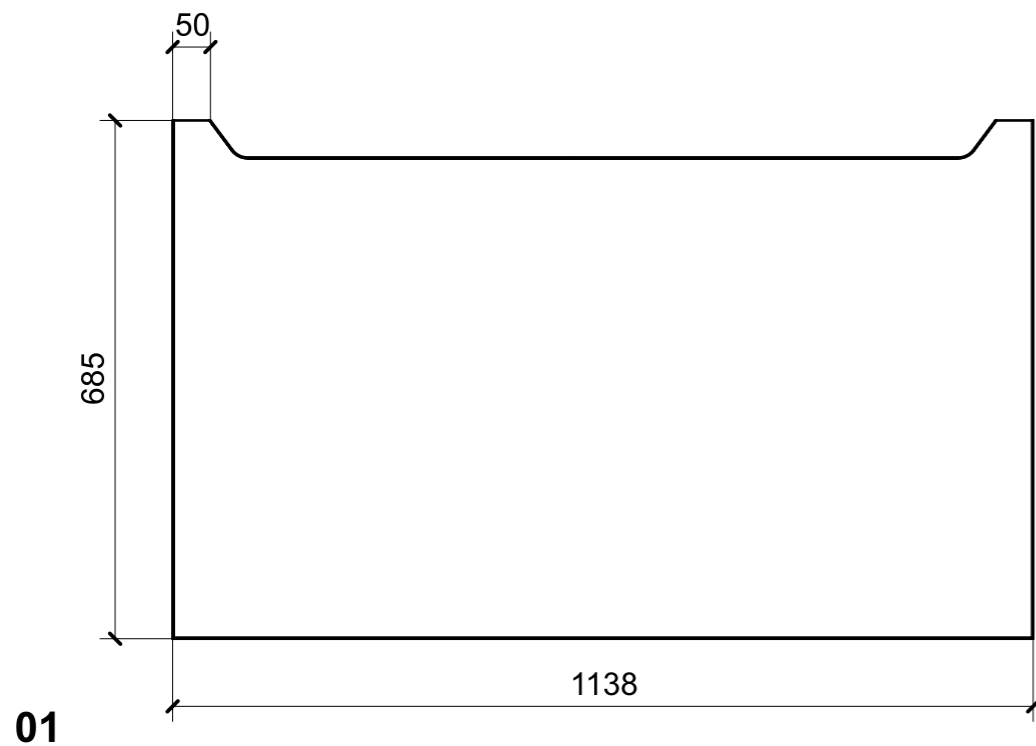

FERRAMENTA	QTY
BUSSOLA 6MA X 10 FORO DIAM.8	5
FITLOCK M_MASCHERPA_3MM_6020202101	6

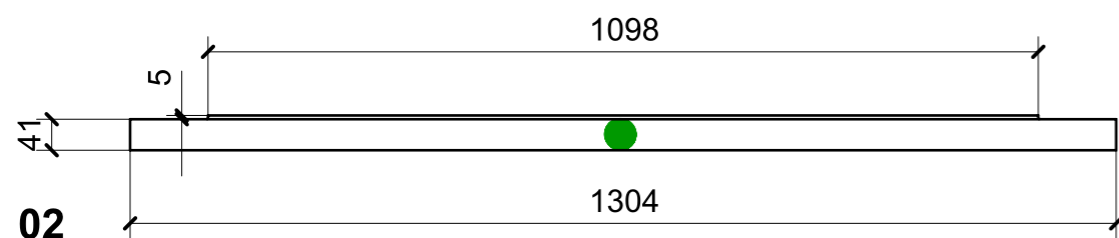

VERNICIATURA LAISTRA/LACCATI:

● = VERNICIARE 1 LATO + FILI RASATI O BORDATI

NESSUN SIMBOLO = VERNICIARE 2 LATI + FILI RASATI O BORDATI

LOCALE	CODICE	DESCRIZIONE COMPONENTE	FINITURA	GR.
LOBBY MD	MD320_R02_CCE01	STRUT. LATO DX MOBILE RACK	LASTRA CHIARA	PTP

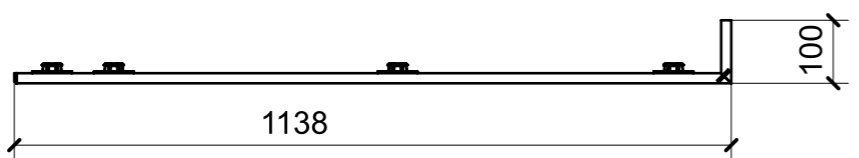
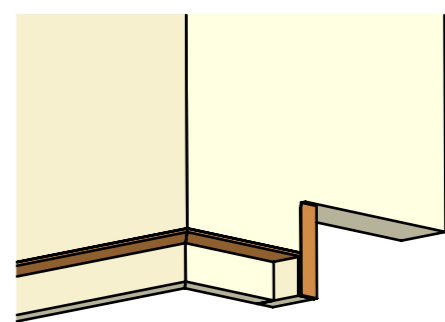
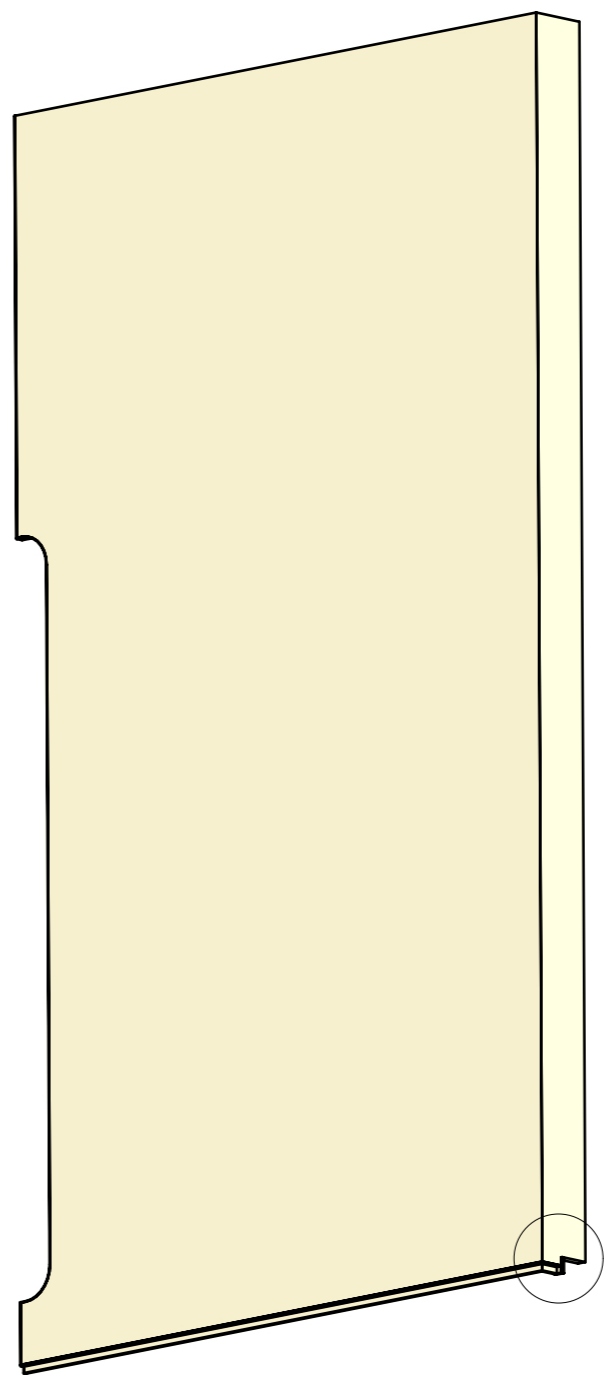
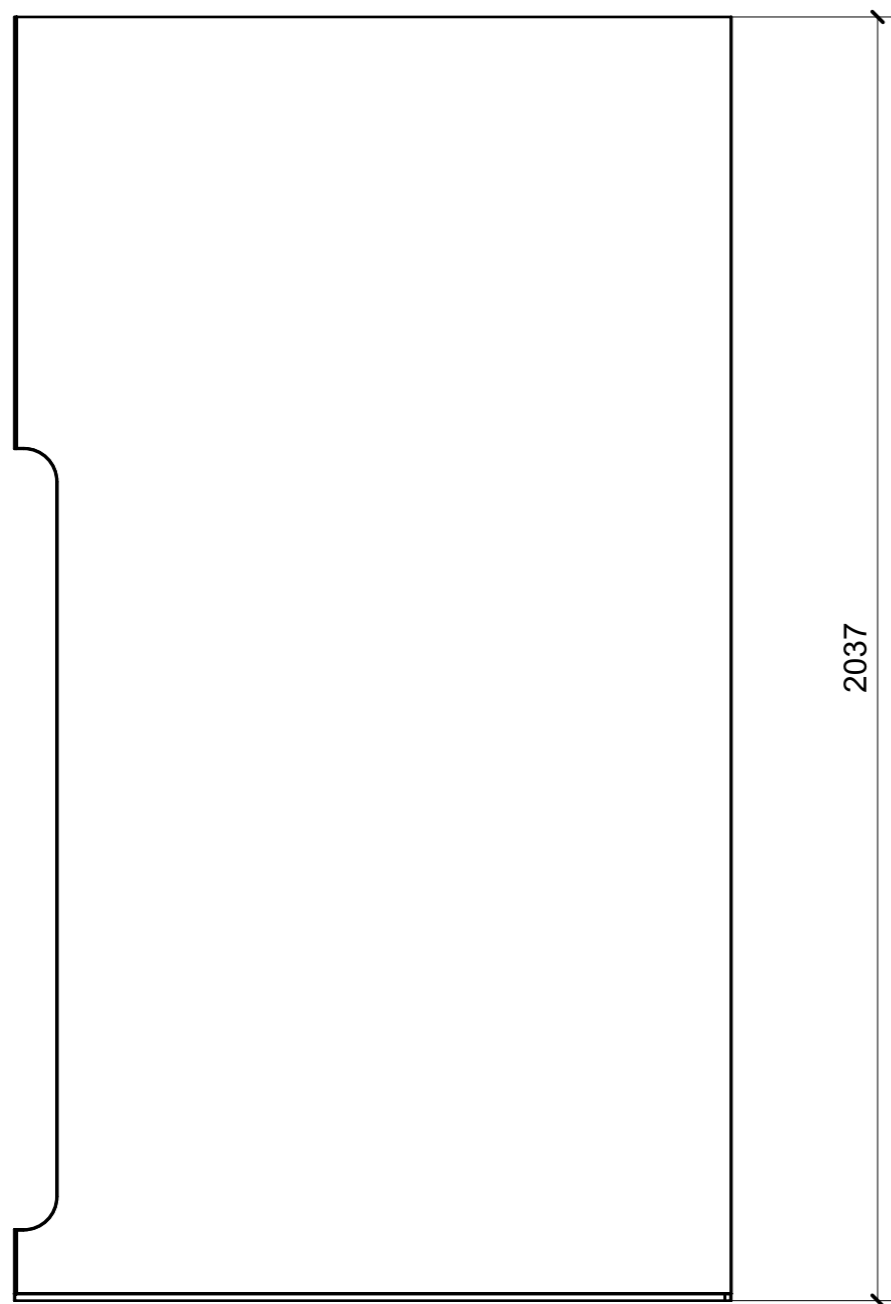

01

FERRAMENTA	QTY
FITLOCK M_MASCHERPA_3MM_6020202101	9

VERNICIATURA LASTRA/LACCATI:

● = VERNICIARE 1 LATO + FILI RASATI O BORDATI

NESSUN SIMBOLO = VERNICIARE 2 LATI + FILI RASATI O BORDATI

LOCALE	CODICE	DESCRIZIONE COMPONENTE	FINITURA	GR.
LOBBY MD	MD320_R01_CCF01	MOBILE AD ANGOLO INGRESSO SALONE	LASTRA SCURA	3

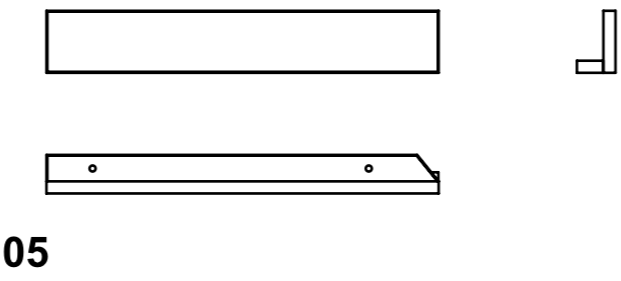
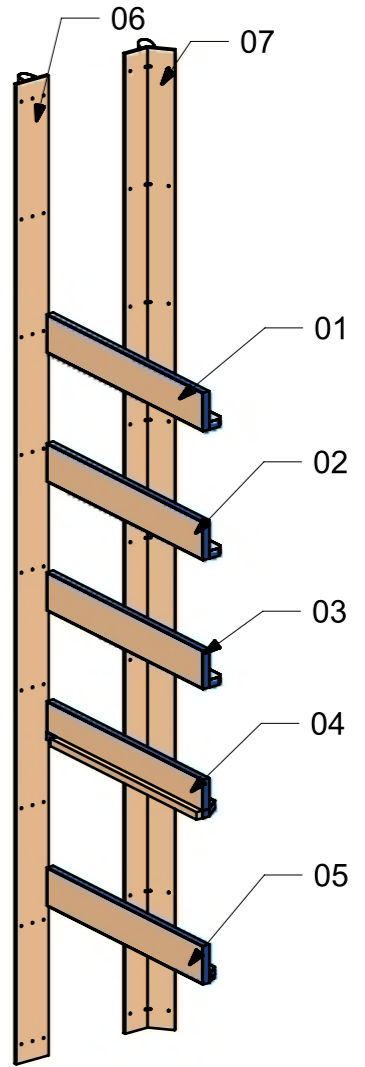
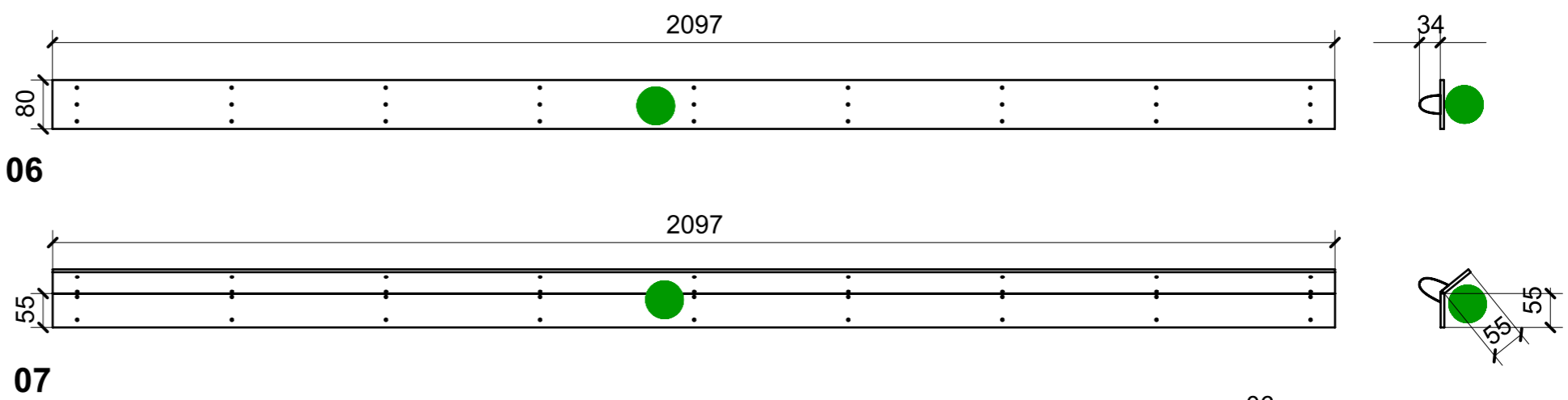
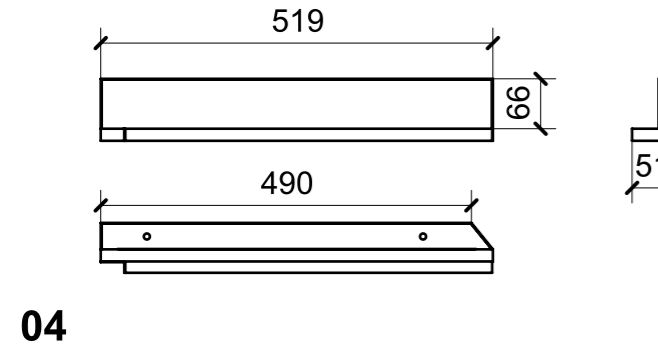
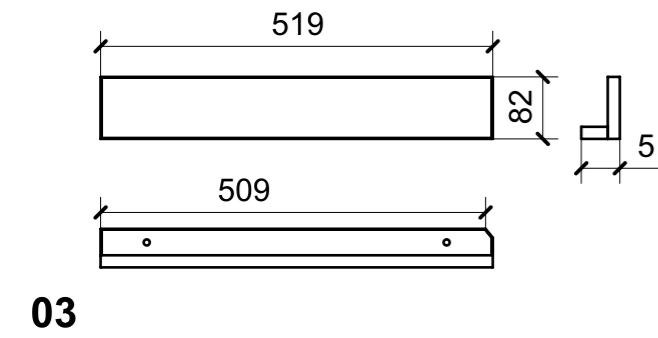
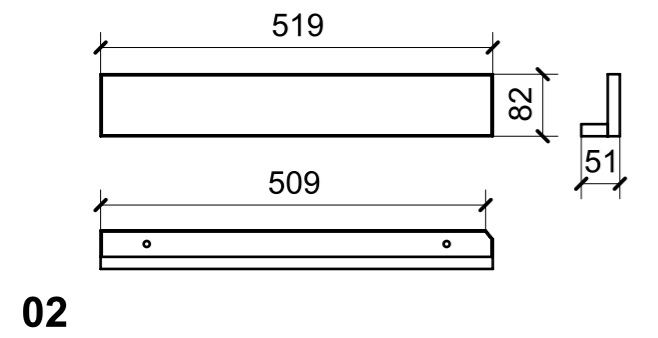
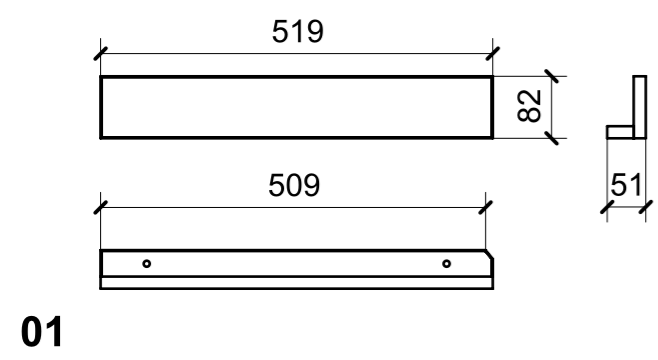

FERRAMENTA	QTY
BUSSOLA 6MA X 10 FORO DIAM.8	10

VERNICIATURA LASTRA/LACCATI:
 ● = VERNICIARE 1 LATO + FILI RASATI O BORDATI NESSUN SIMBOLO = VERNICIARE 2 LATI + FILI RASATI O BORDATI

LOCALE	CODICE	DESCRIZIONE COMPONENTE	FINITURA	GR.
LOBBY MD	MD320_R02_CCF01	MOBILE AD ANGOLO INGRESSO SALONE	LASTRA CHIARA	3

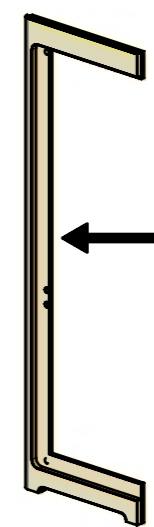
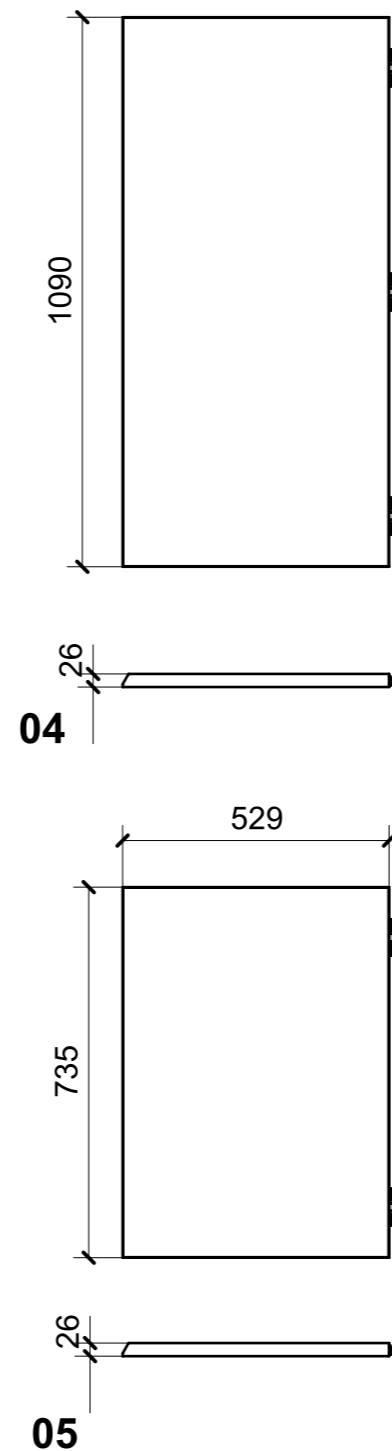
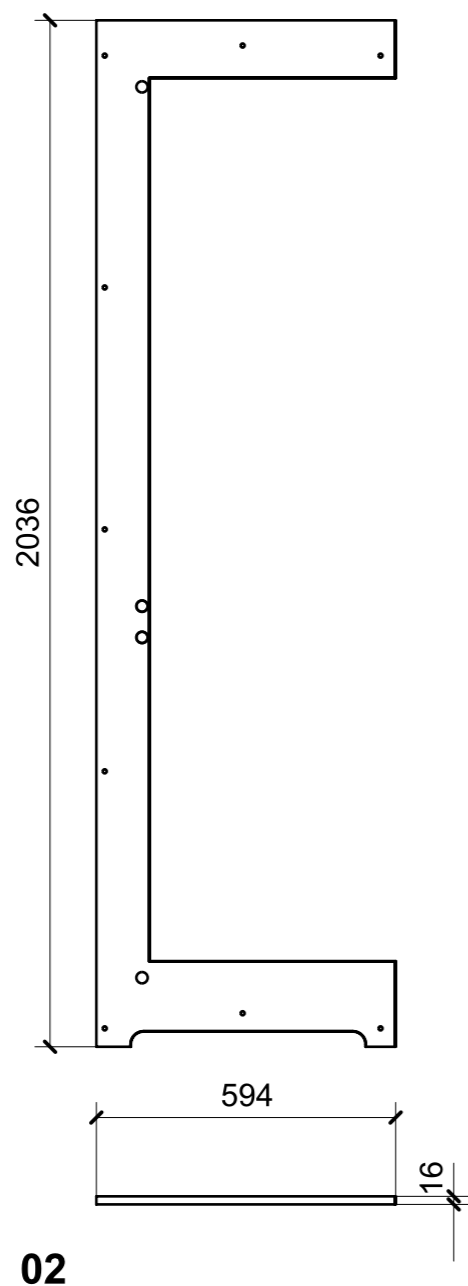
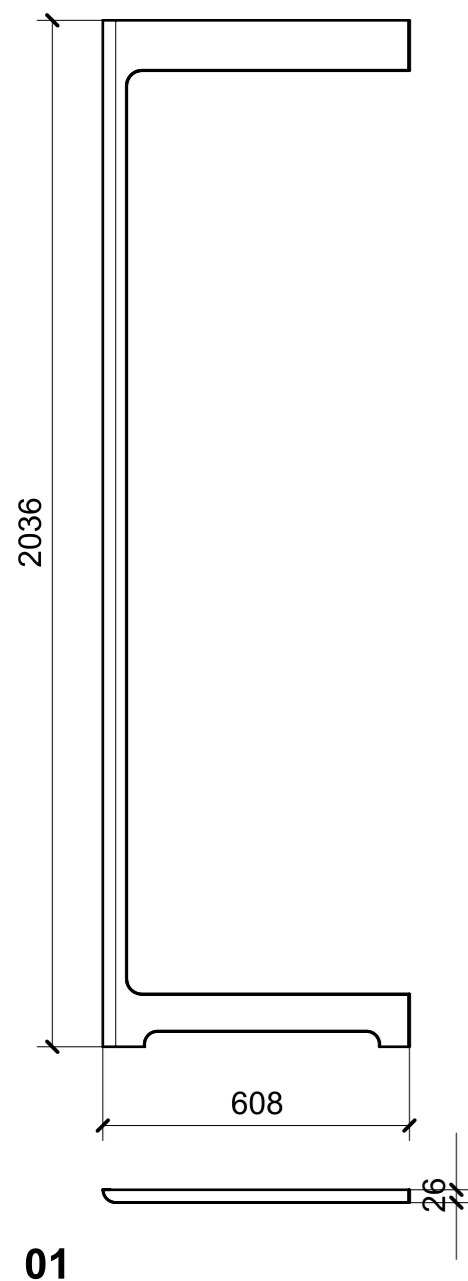

ELEMENTI DA MONTARE
in MG_CCF02
e spedire con unico imballo

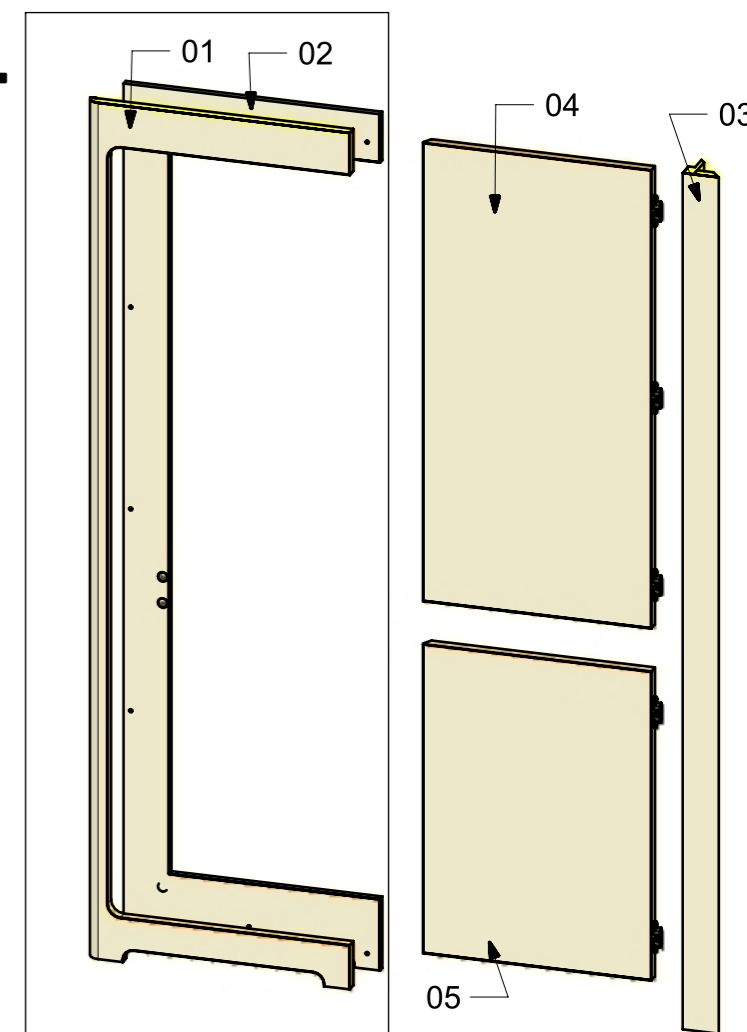

FERRAMENTA	QTY
CERNIERA A SCOMPARSA KUBIKINA-K6100 NO HD_ KOBLENZ	5
BUSSOLA 6MA X 10 FORO DIAM.8	9
MAGNETE FORZA MAGNETICA1-5 10KG_HAFELE_246.87.112	8

VERNICIATURA LASTRA/LACCATI:

● = VERNICIARE 1 LATO + FILI RASATI O BORDATI

NESSUN SIMBOLO = VERNICIARE 2 LATI + FILI RASATI O BORDATI

LOCALE	CODICE	DESCRIZIONE COMPONENTE	FINITURA	GR.
LOBBY MD	MD320_R01_CCH01	GRADINO	LASTRA SCURA	PTP

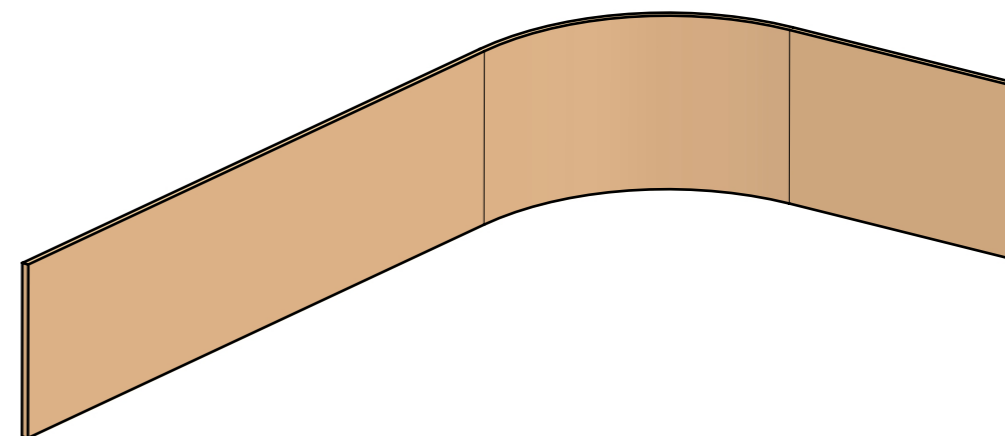
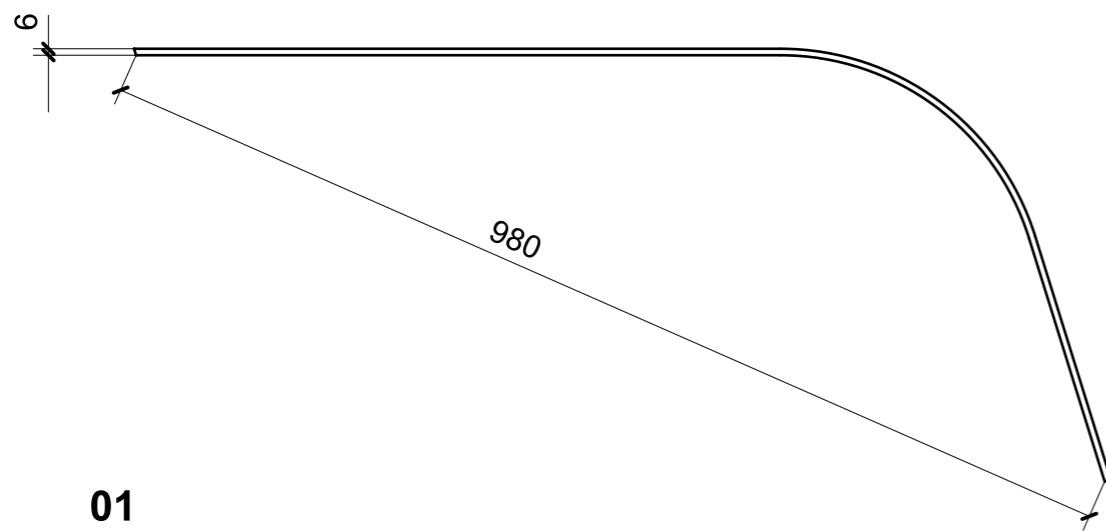

VERNICIATURA LASTRA/LACCATI:

● = VERNICIARE 1 LATO + FILI RASATI O BORDATI

NESSUN SIMBOLO = VERNICIARE 2 LATI + FILI RASATI O BORDATI

LOCALE	CODICE	DESCRIZIONE COMPONENTE	FINITURA	GR.
LOBBY MD	MD320_R02_CCH01	GRADINO	LASTRA CHIARA	PTP

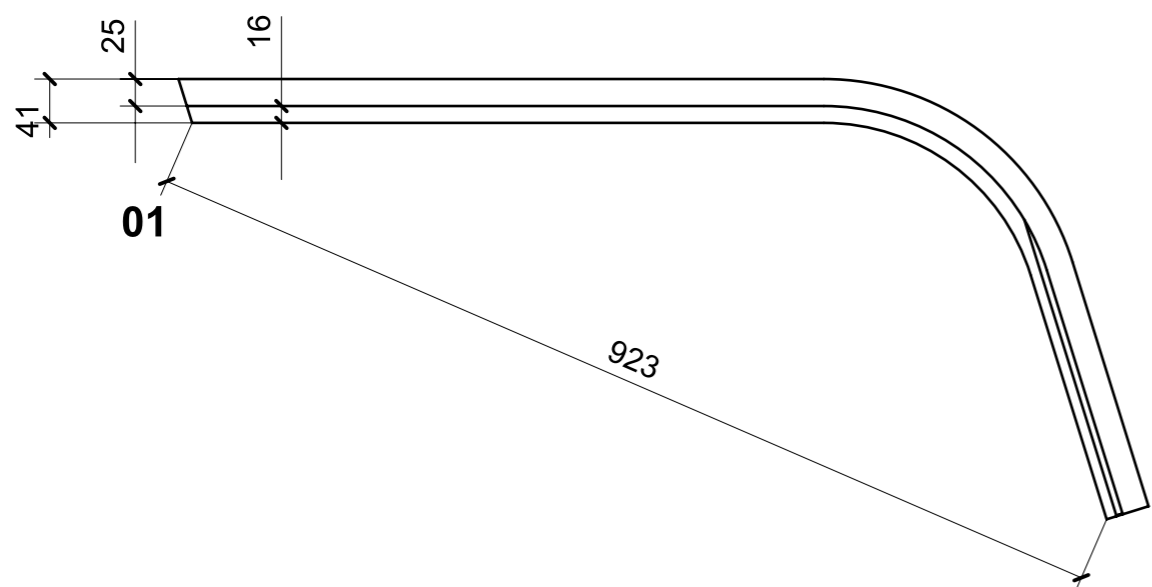
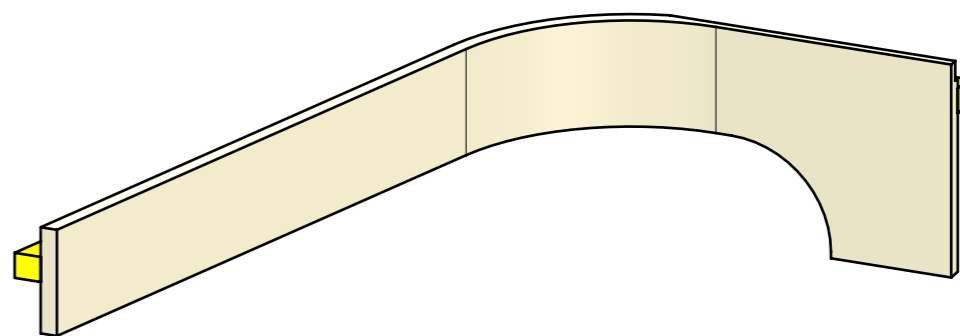
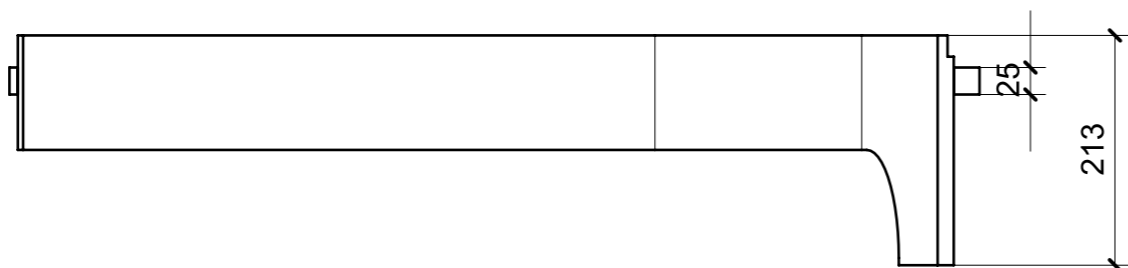

VERNICIATURA LASTRA/LACCATI:

● = VERNICIARE 1 LATO + FILI RASATI O BORDATI

NESSUN SIMBOLO = VERNICIARE 2 LATI + FILI RASATI O BORDATI

LOCALE	CODICE	DESCRIZIONE COMPONENTE	FINITURA	GR.
LOBBY MD	MD320_R02_CCL01	DISCESA SCALE LATO ARMATORE	LASTRA CHIARA	2

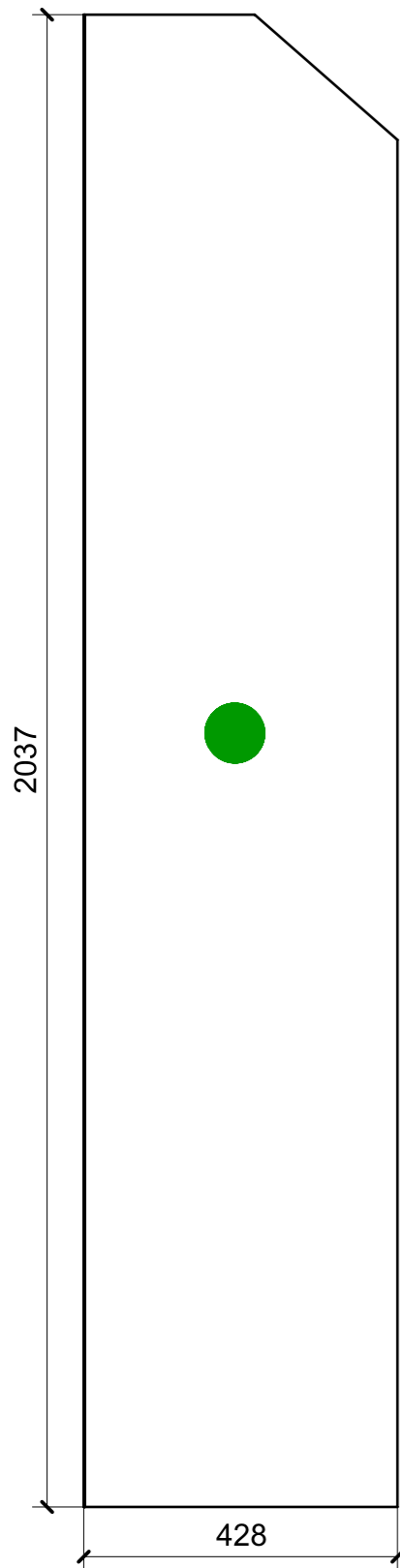

01



02

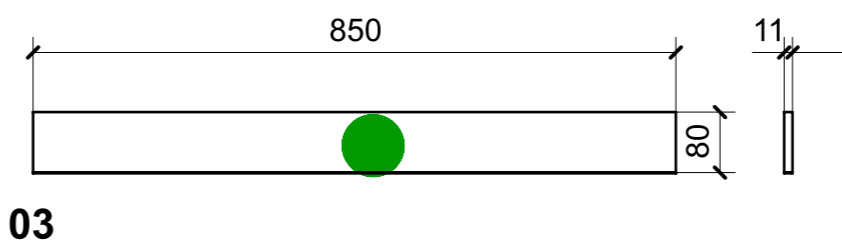
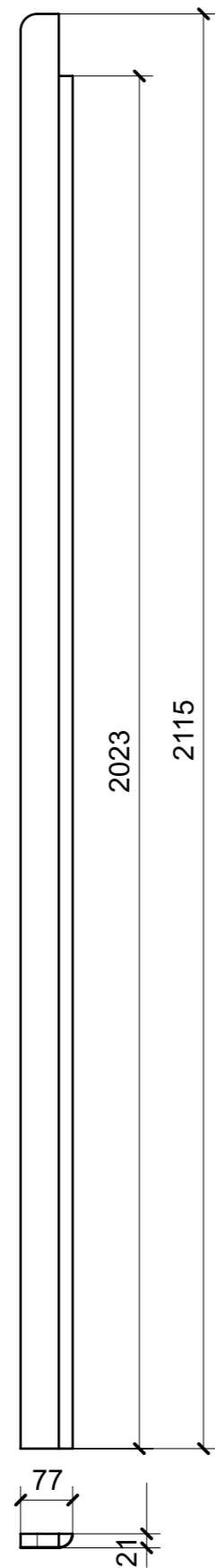

03

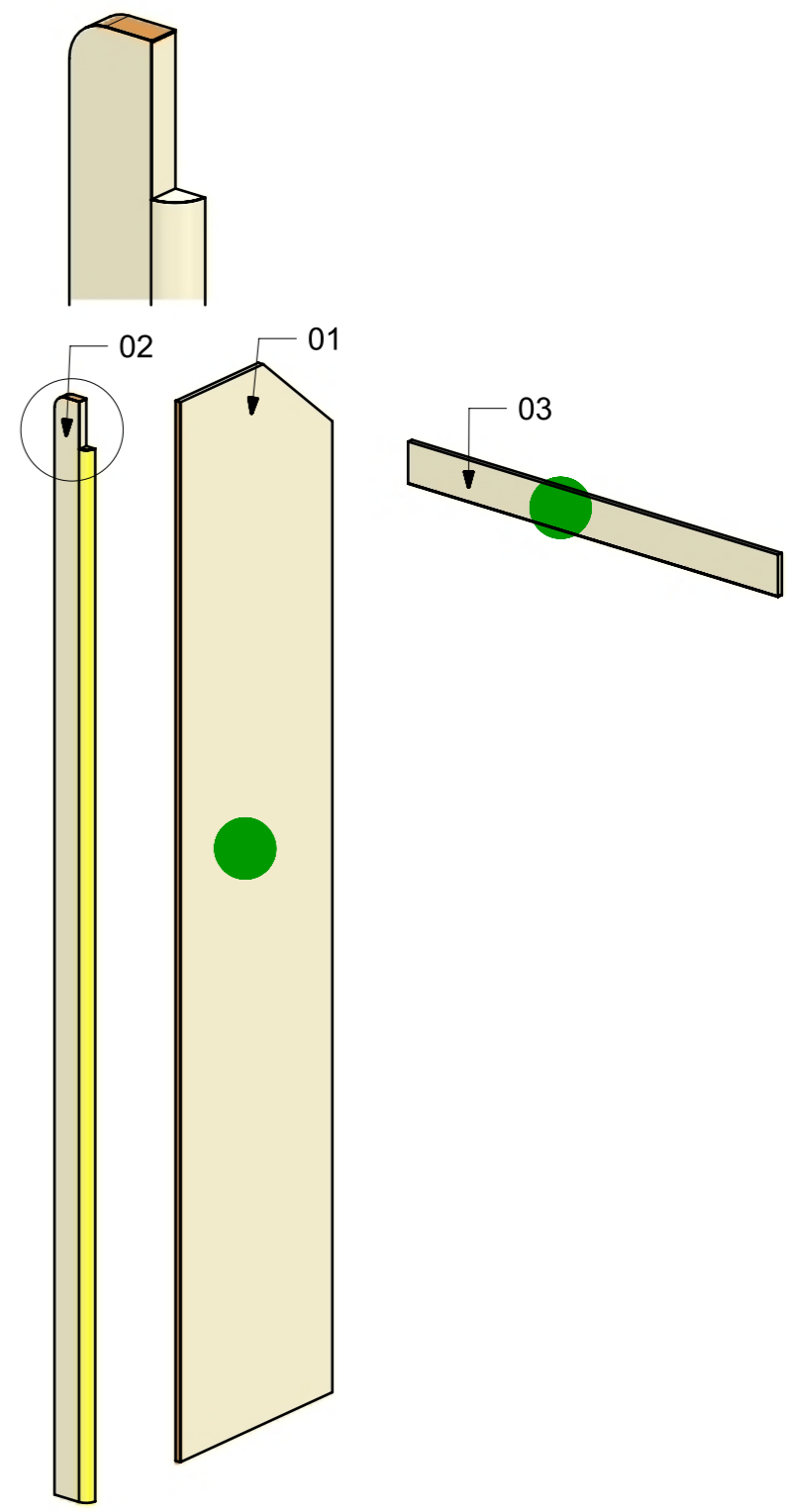

VERNICIATURA LASTRA/LACCATI:

● = VERNICIARE 1 LATO + FILI RASATI O BORDATI

NESSUN SIMBOLO = VERNICIARE 2 LATI + FILI RASATI O BORDATI

LOCALE	CODICE	DESCRIZIONE COMPONENTE	FINITURA	GR.
LOBBY MD	MD320_R02_CCM01	RIV. GRADINO PORTA SCORREVOLE	LASTRA CHIARA	PTP

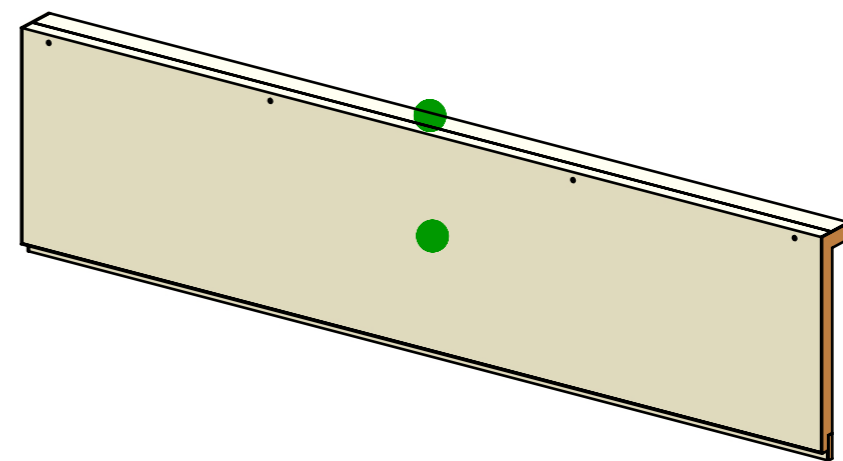
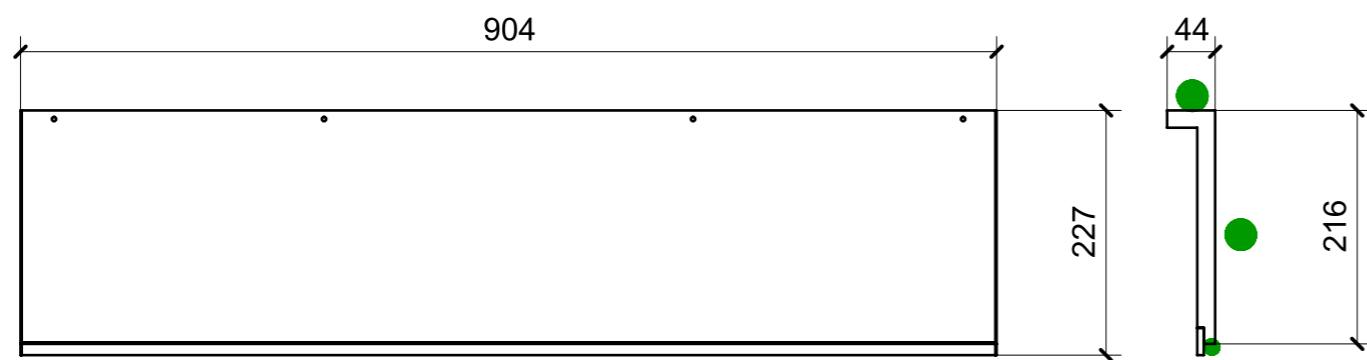

01

VERNICIATURA LASTRA/LACCATI:

● = VERNICIARE 1 LATO + FILI RASATI O BORDATI

NESSUN SIMBOLO = VERNICIARE 2 LATI + FILI RASATI O BORDATI

LOCALE	CODICE	DESCRIZIONE COMPONENTE	FINITURA	GR.
LOBBY MD	MD320_R02_CCN01	STRUTTURA RIV. DI POPPA PORTA SCORREVOLE	LASTRA CHIARA	3

ELEMENTO DA MONTARE
 con X01_CCN01_01 in MF_CCN01
 e spedire con unico imballo

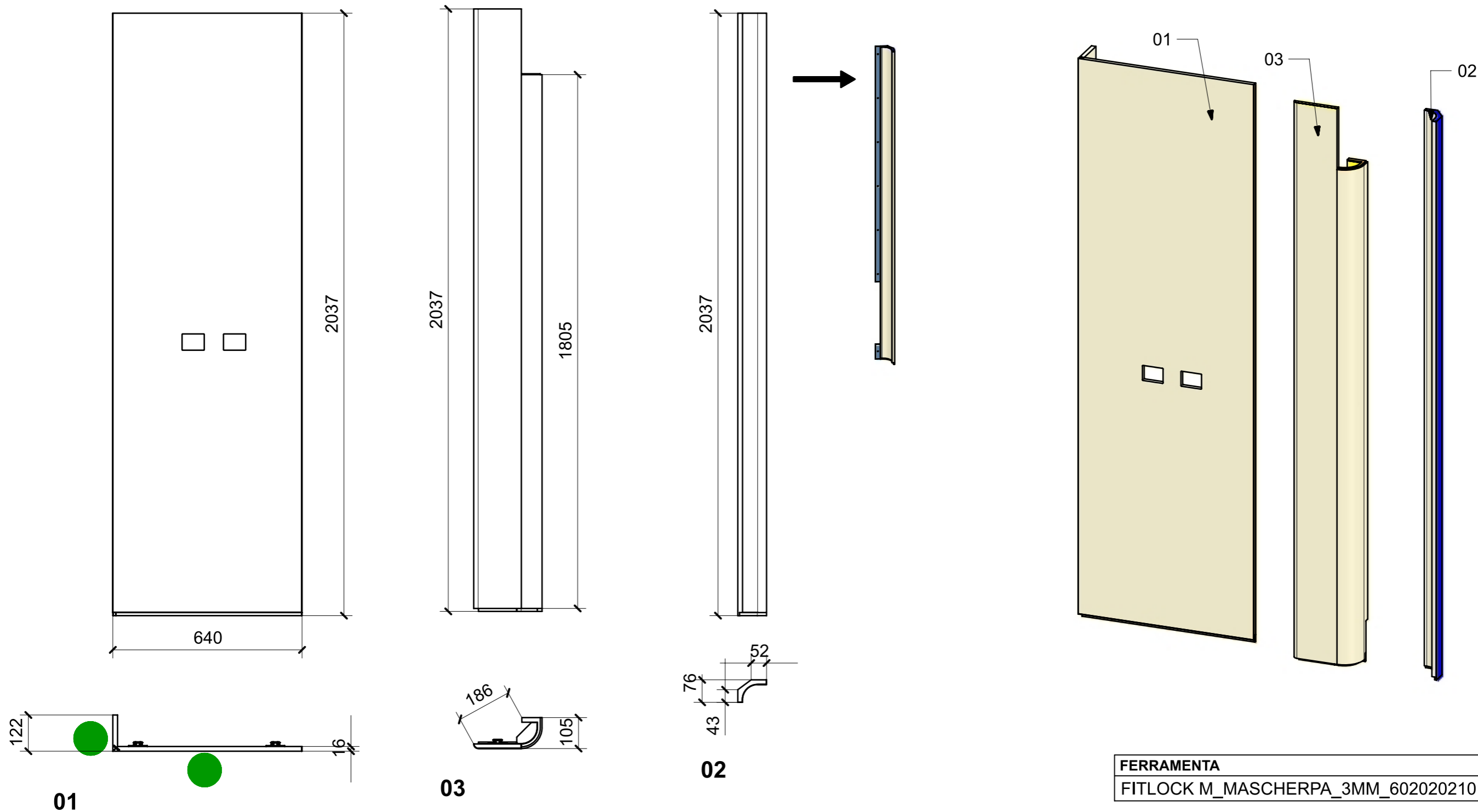

FERRAMENTA	QTY
FITLOCK M_MASCHERPA_3MM_6020202101	9

VERNICIATURA LASTRA/LACCATI:

● = VERNICIARE 1 LATO + FILI RASATI O BORDATI

NESSUN SIMBOLO = VERNICIARE 2 LATI + FILI RASATI O BORDATI

LOCALE	CODICE	DESCRIZIONE COMPONENTE	FINITURA	GR.
LOBBY MD	MD320_R01_CCO01	RIV. PARATIA IMPIANTI DAY TOILET	LASTRA SCURA	PTP

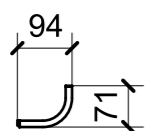
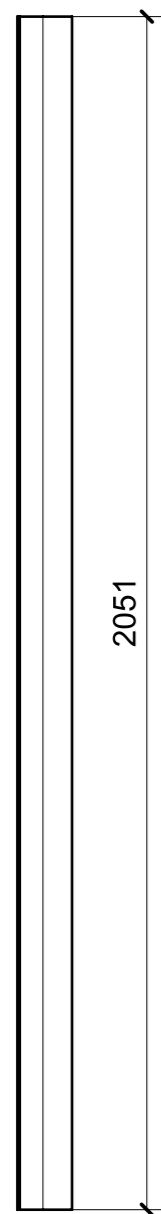

01

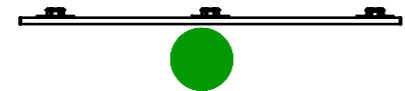
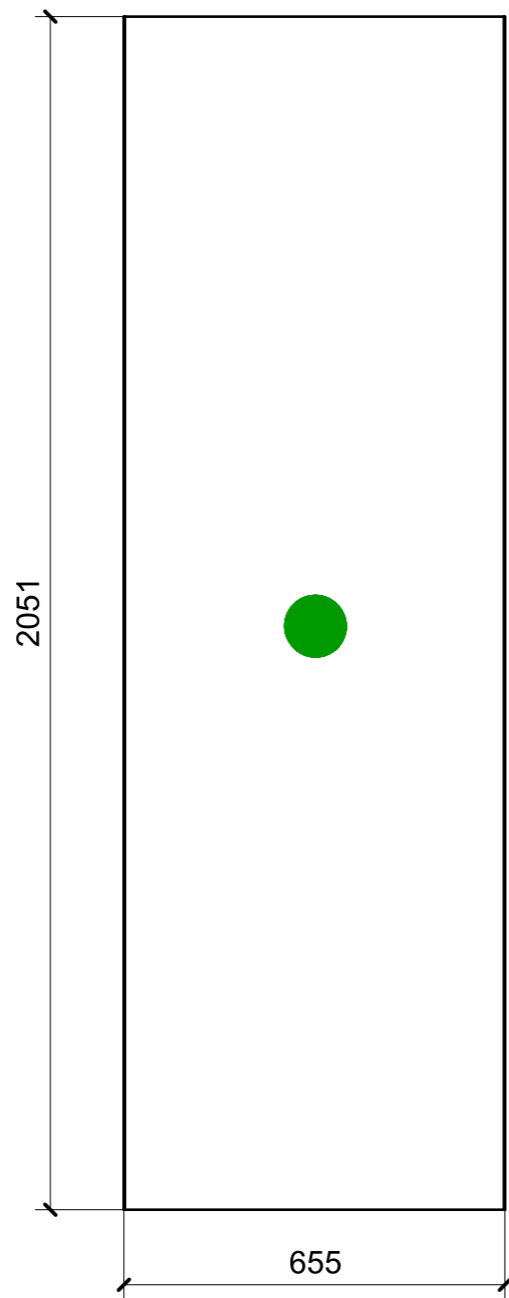

02

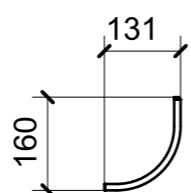
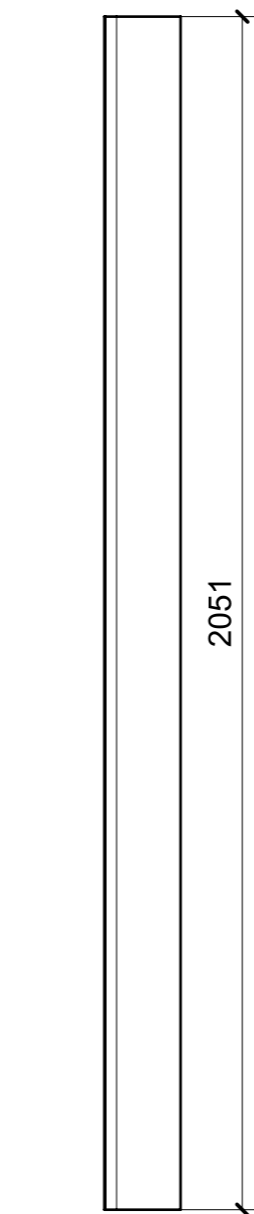

03

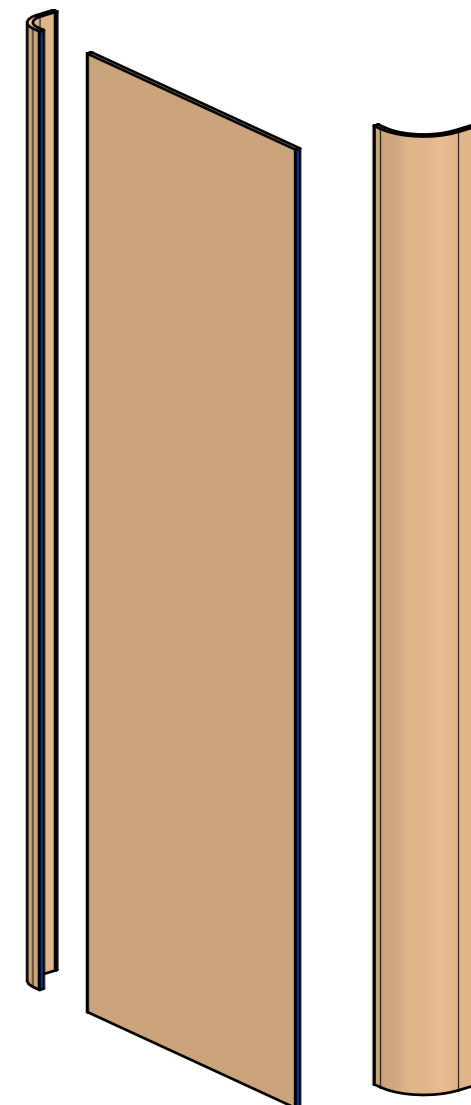

FERRAMENTA	QTY
FITLOCK M_MASCHERPA_3MM_6020202101	11

VERNICIATURA LASTRA/LACCATI:

● = VERNICIARE 1 LATO + FILI RASATI O BORDATI

NESSUN SIMBOLO = VERNICIARE 2 LATI + FILI RASATI O BORDATI