

| LOCALE | CODICE | DESCRIZIONE COMPONENTE | FINITURA | GR |
|---------------|-----------------|--------------------------------|---------------|----|
| CABINA VIP SX | MD320_R02_VVA01 | STRUTTURA MURATA TESTATA LETTO | LASTRA CHIARA | 6 |

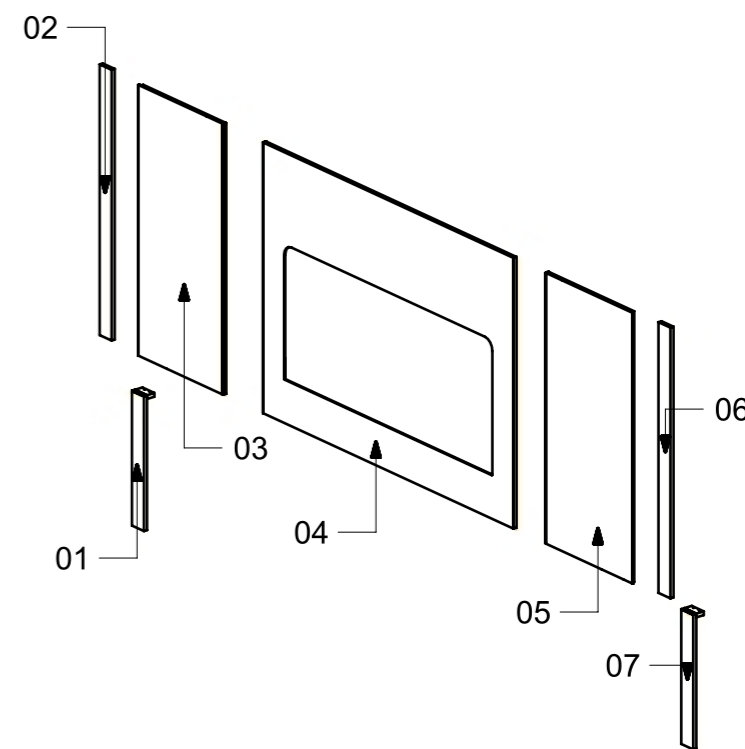
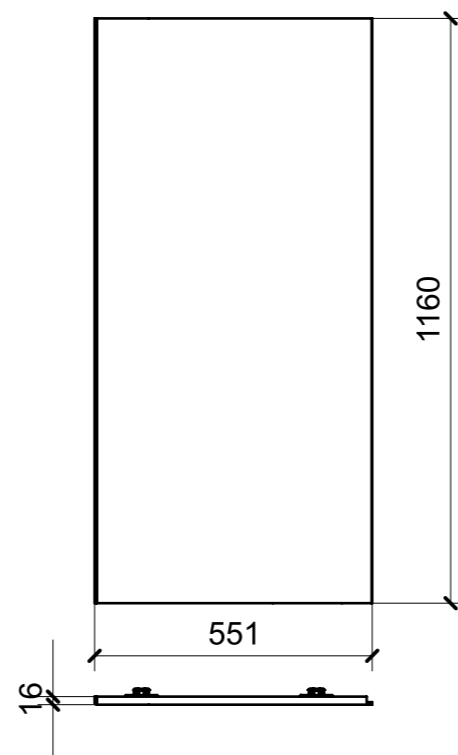
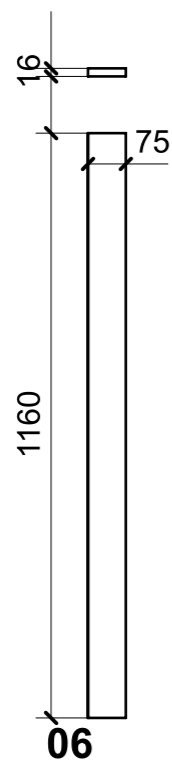
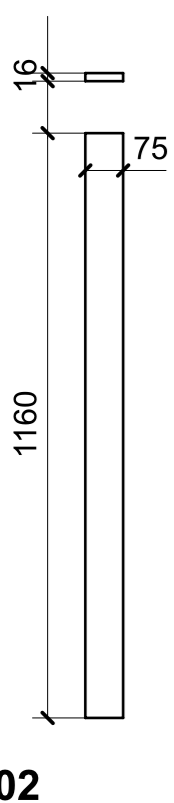
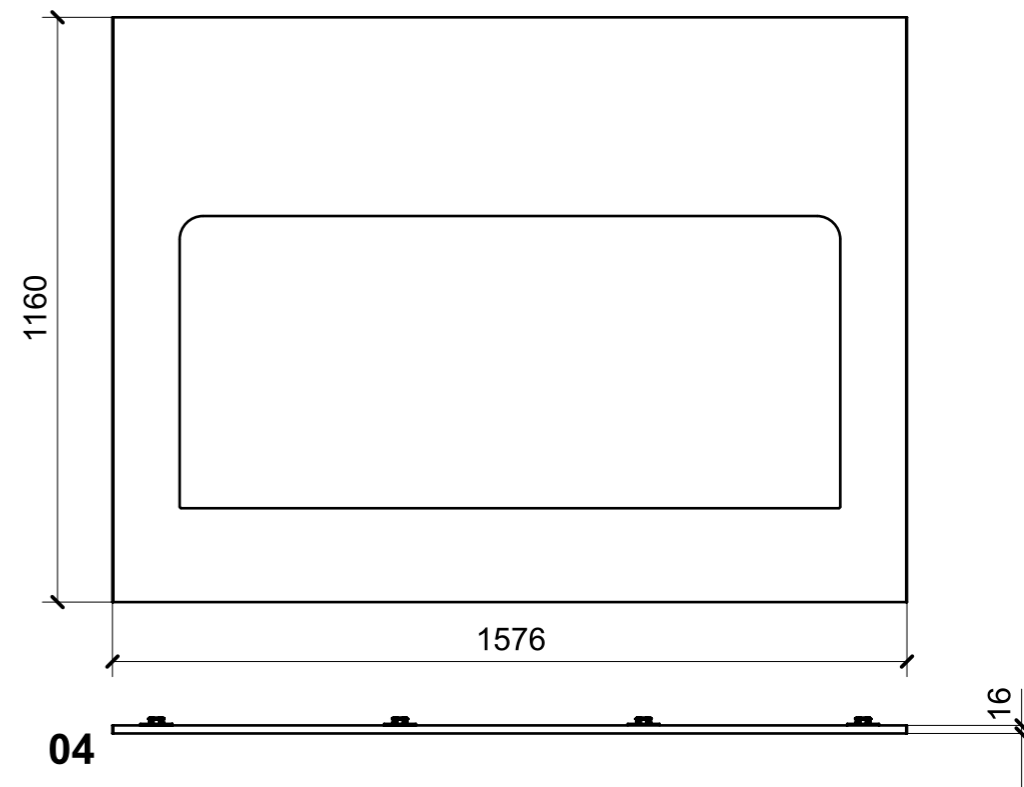
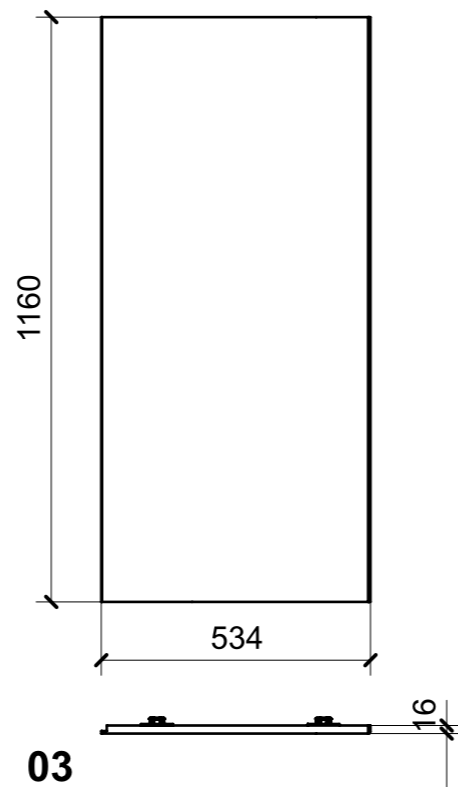
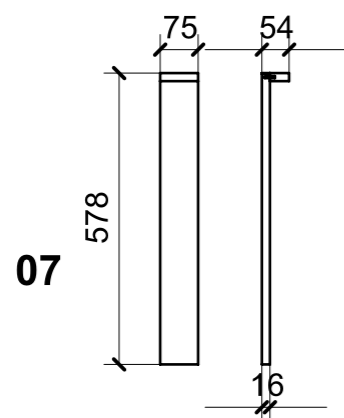
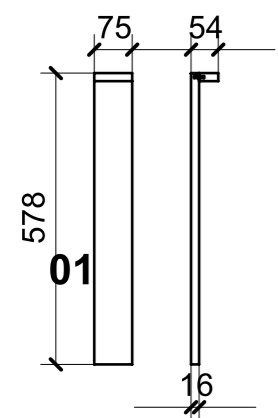

| FERRAMENTA | QTY |
|------------------------------------|-----|
| FITLOCK M_MASCHERPA_3MM_6020202101 | 20 |

VERNICIATURA LASTRA/LACCATI: ● = VERNICIARE 1 LATO + FILI RASATI O BORDATI NESSUN SIMBOLO = VERNICIARE 2 LATI + FILI RASATI O BORDATI

| LOCALE | CODICE | DESCRIZIONE COMPONENTE | FINITURA | Q.TA |
|---------------|-----------------|--------------------------|--------------|------|
| CABINA VIP SX | MD320_R01_VVE01 | RIVESTIMENTI PARETI PRUA | LASTRA SCURA | 3 |

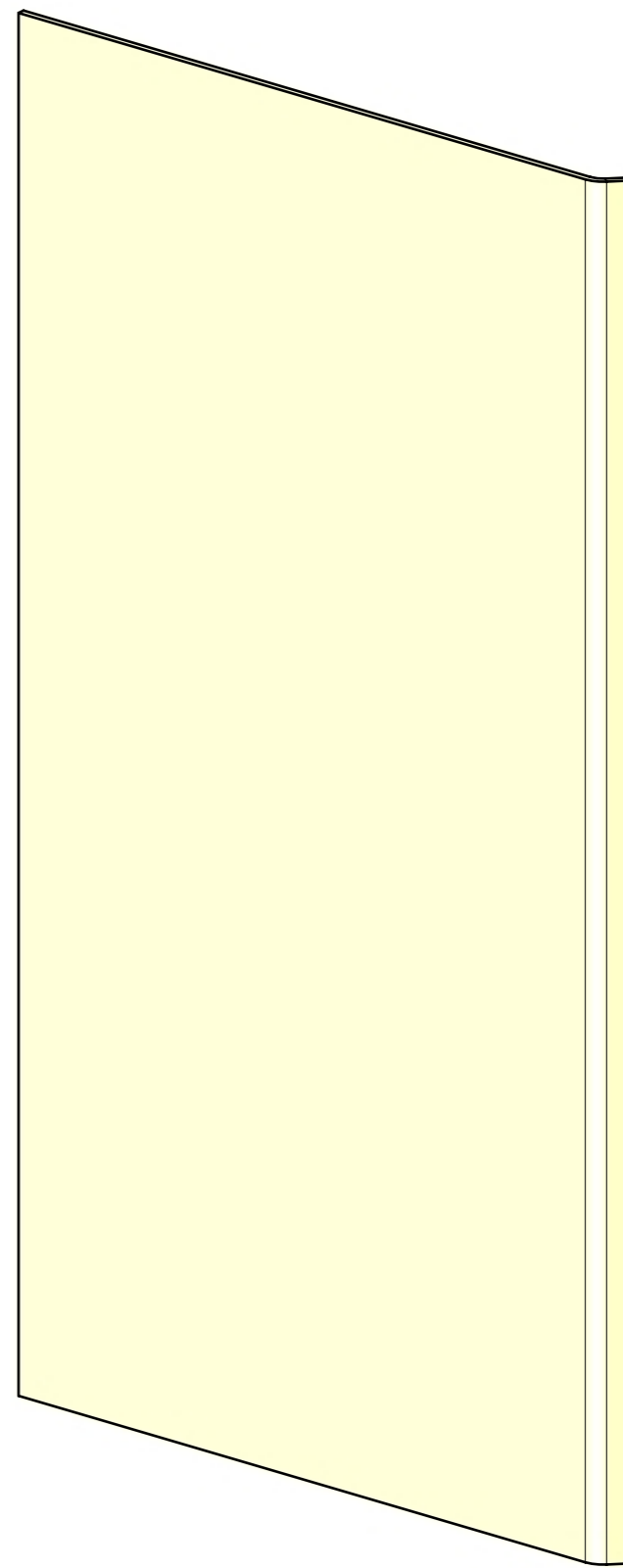
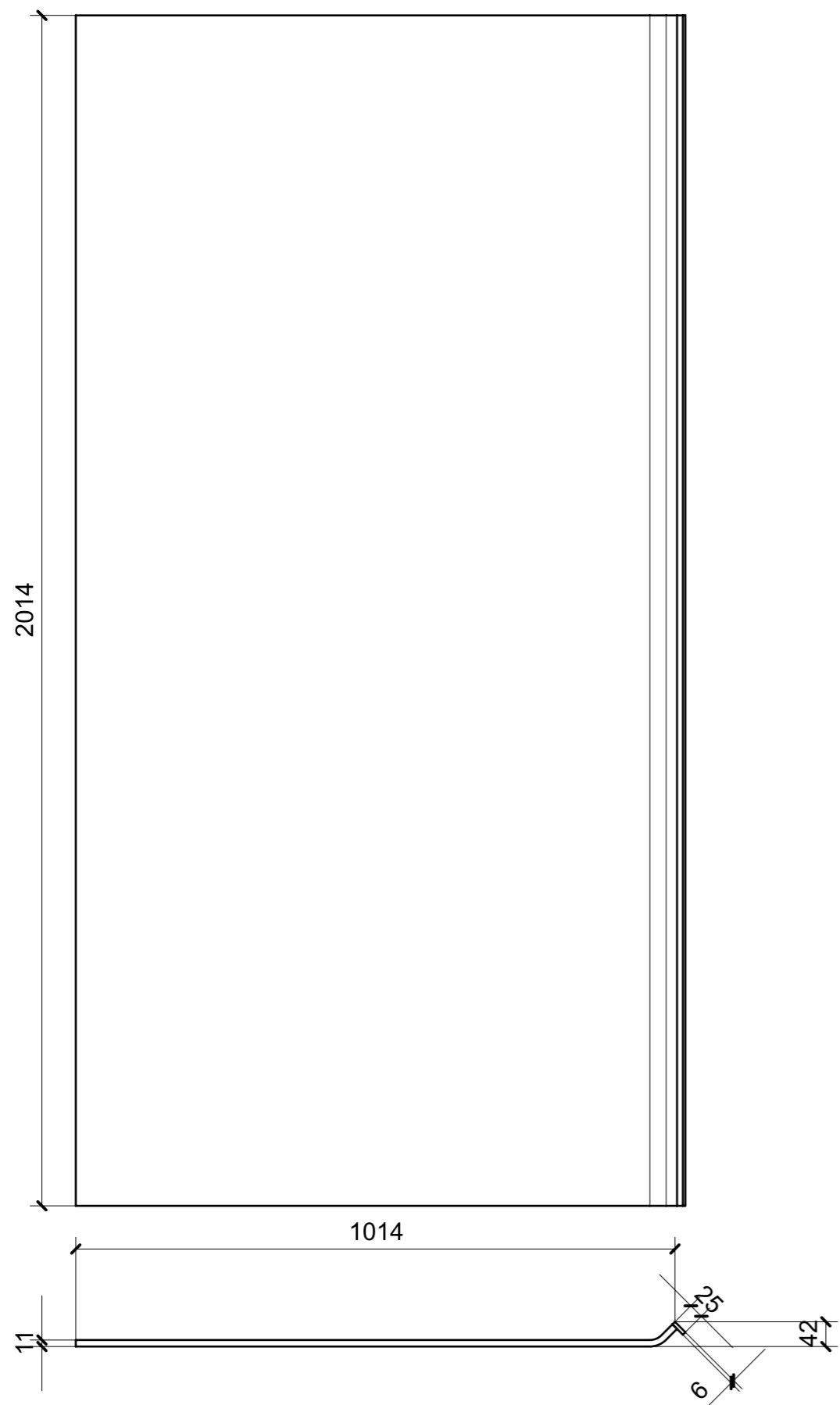

VERNICIATURA LASTRA/LACCATI:

● = VERNICIARE 1 LATO + FILI RASATI O BORDATI

NESSUN SIMBOLO = VERNICIARE 2 LATI + FILI RASATI O BORDATI

| LOCALE | CODICE | DESCRIZIONE COMPONENTE | FINITURA | Q.TA |
|---------------|-----------------|--------------------------|---------------|------|
| CABINA VIP SX | MD320_R02_VVE01 | RIVESTIMENTI PARETI PRUA | LASTRA CHIARA | 3 |

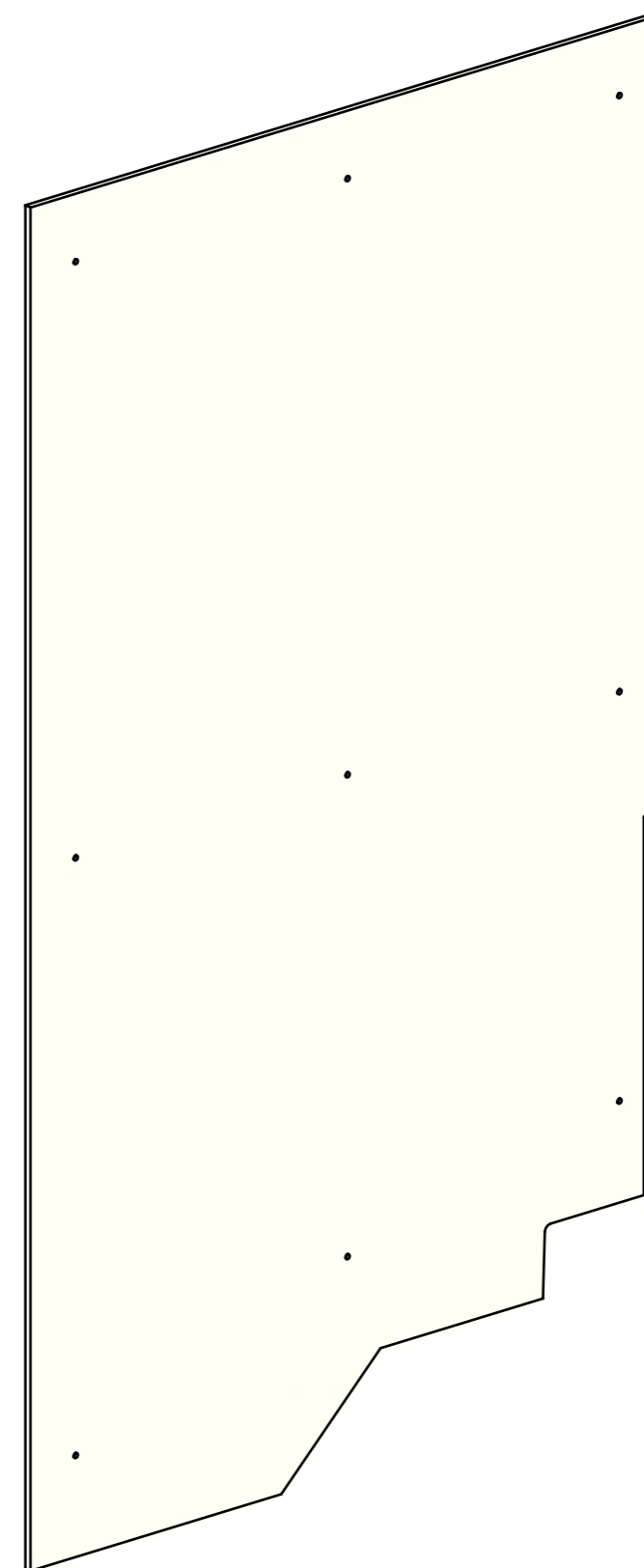
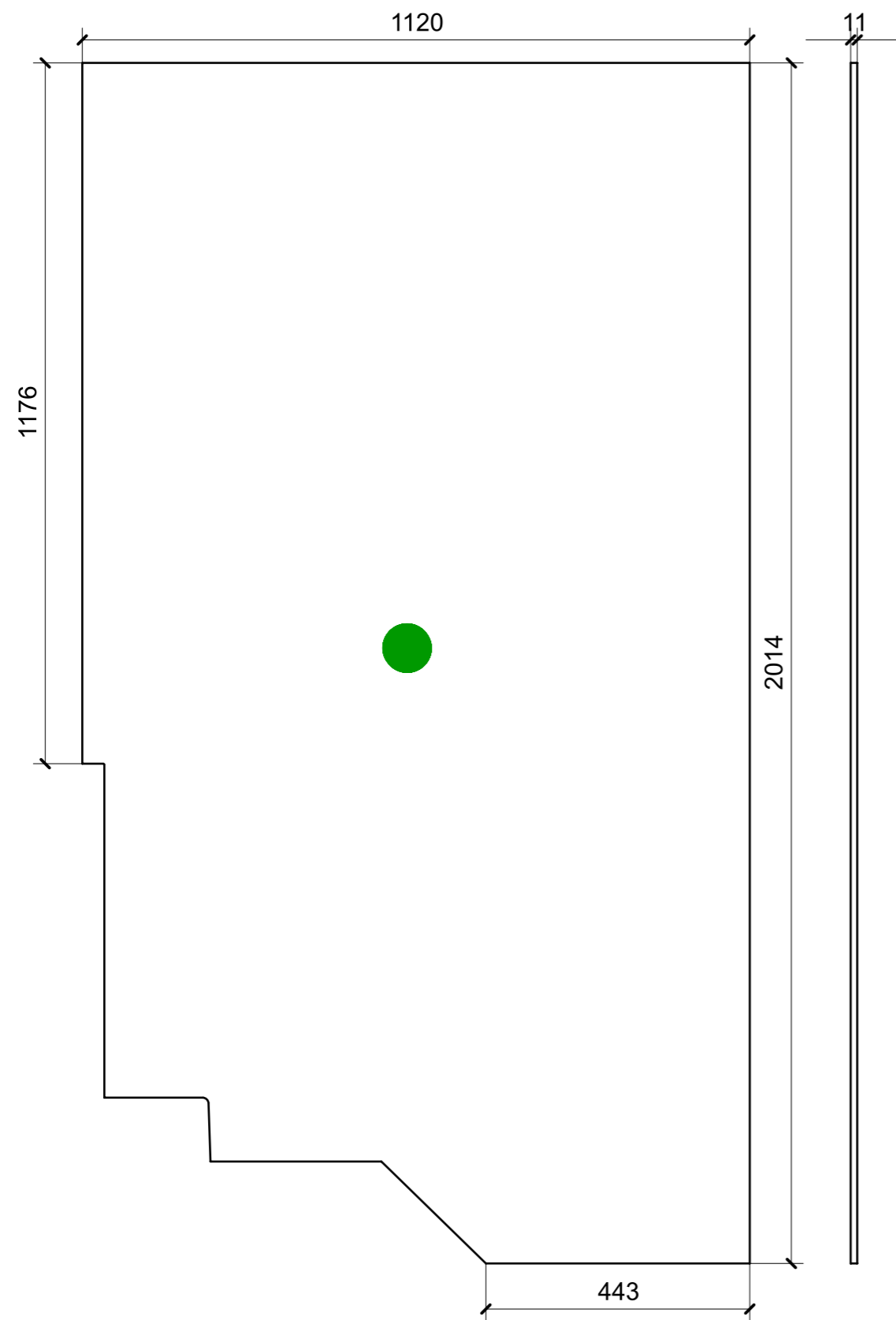

VERNICIATURA LASTRA/LACCATI:

● = VERNICIARE 1 LATO + FILI RASATI O BORDATI

NESSUN SIMBOLO = VERNICIARE 2 LATI + FILI RASATI O BORDATI

| LOCALE | CODICE | DESCRIZIONE COMPONENTE | FINITURA | GR |
|---------------|-----------------|---------------------------|--------------|----|
| CABINA VIP SX | MD320_R01_VVF01 | RIVESTIMENTI PARETI POPPA | LASTRA SCURA | 3 |

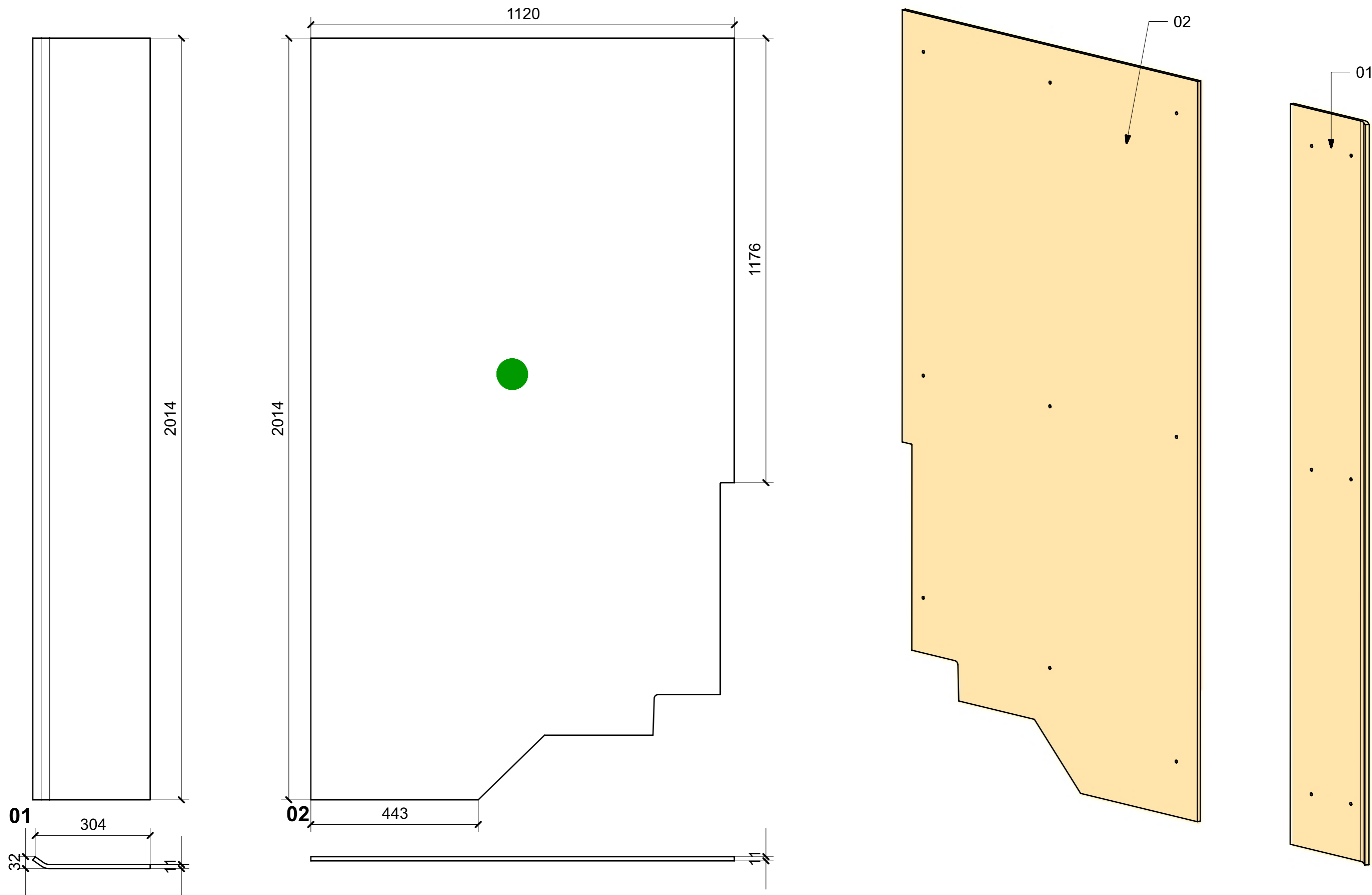

VERNICIATURA LASTRA/LACCATI: ● = VERNICIARE 1 LATO + FILI RASATI O BORDATI NESSUN SIMBOLO = VERNICIARE 2 LATI + FILI RASATI O BORDATI

| LOCALE | CODICE | DESCRIZIONE COMPONENTE | FINITURA | GR |
|---------------|-----------------|---------------------------|---------------|----|
| CABINA VIP SX | MD320_R02_VVF01 | RIVESTIMENTI PARETI POPPA | LASTRA CHIARA | 3 |

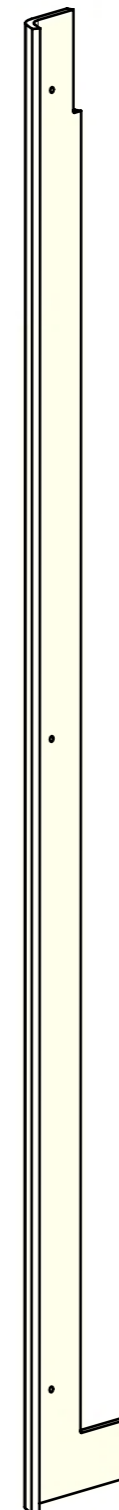
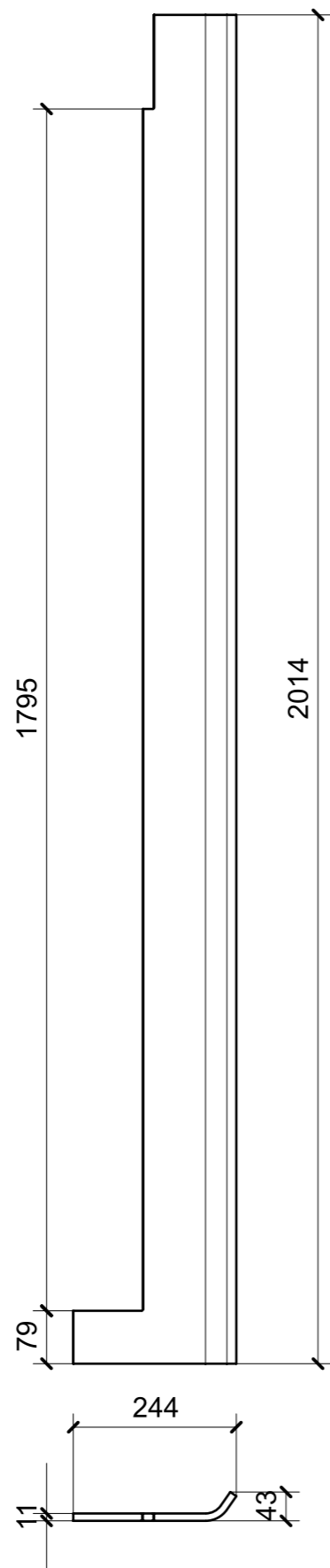

VERNICIATURA LASTRA/LACCATI: ● = VERNICIARE 1 LATO + FILI RASATI O BORDATI

NESSUN SIMBOLO = VERNICIARE 2 LATI + FILI RASATI O BORDATI

| LOCALE | CODICE | DESCRIZIONE COMPONENTE | FINITURA | GR |
|---------------|-----------------|---------------------------------|---------------|----|
| CABINA VIP SX | MD320_R02_VVG01 | RIVESTIMENTI PARETI CENTRO NAVE | LASTRA CHIARA | 3 |

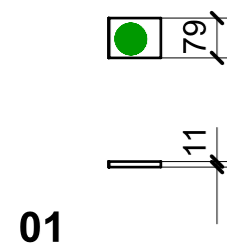
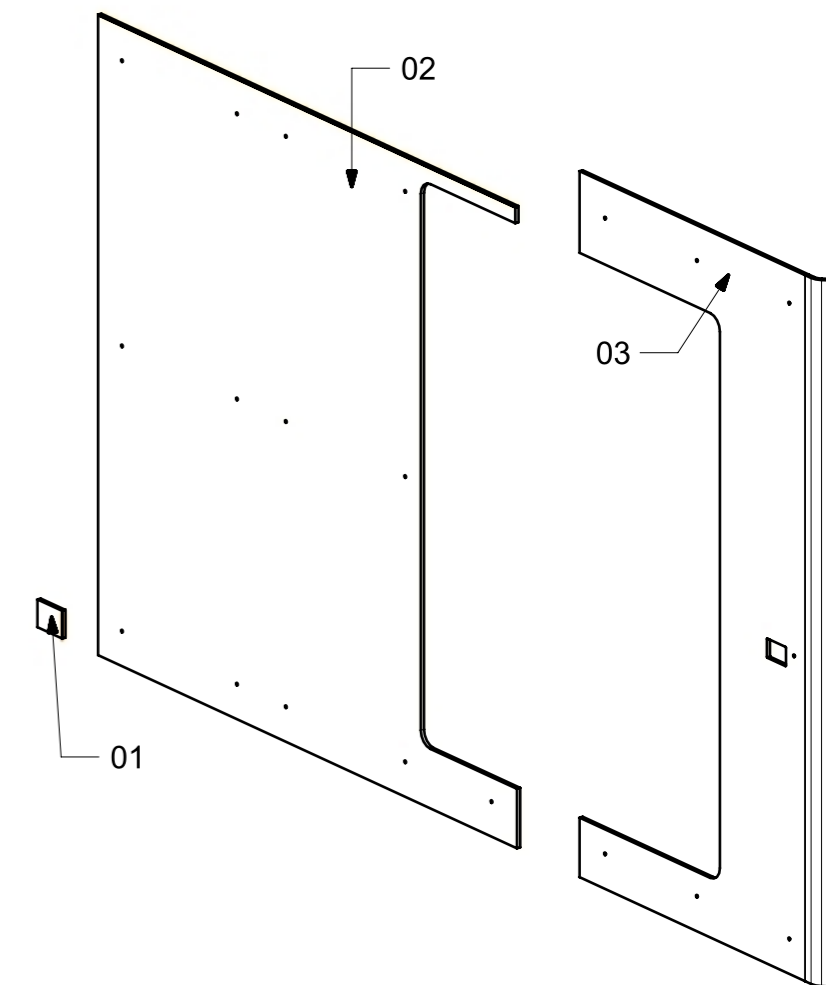
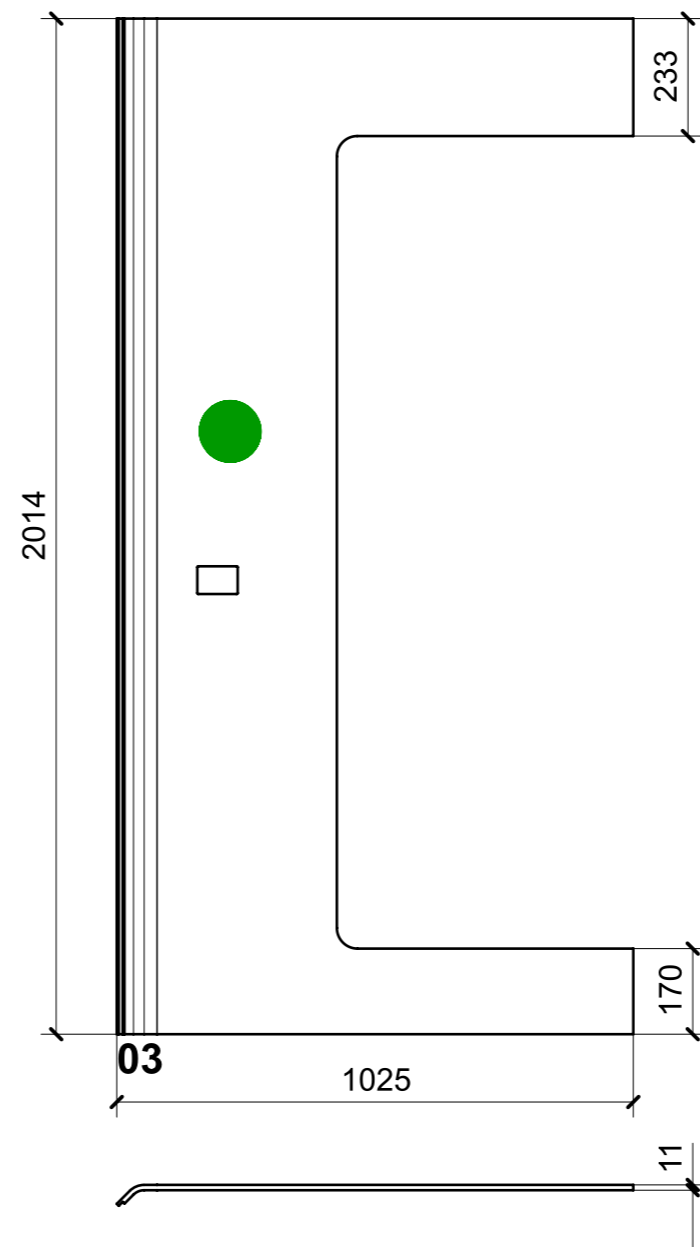
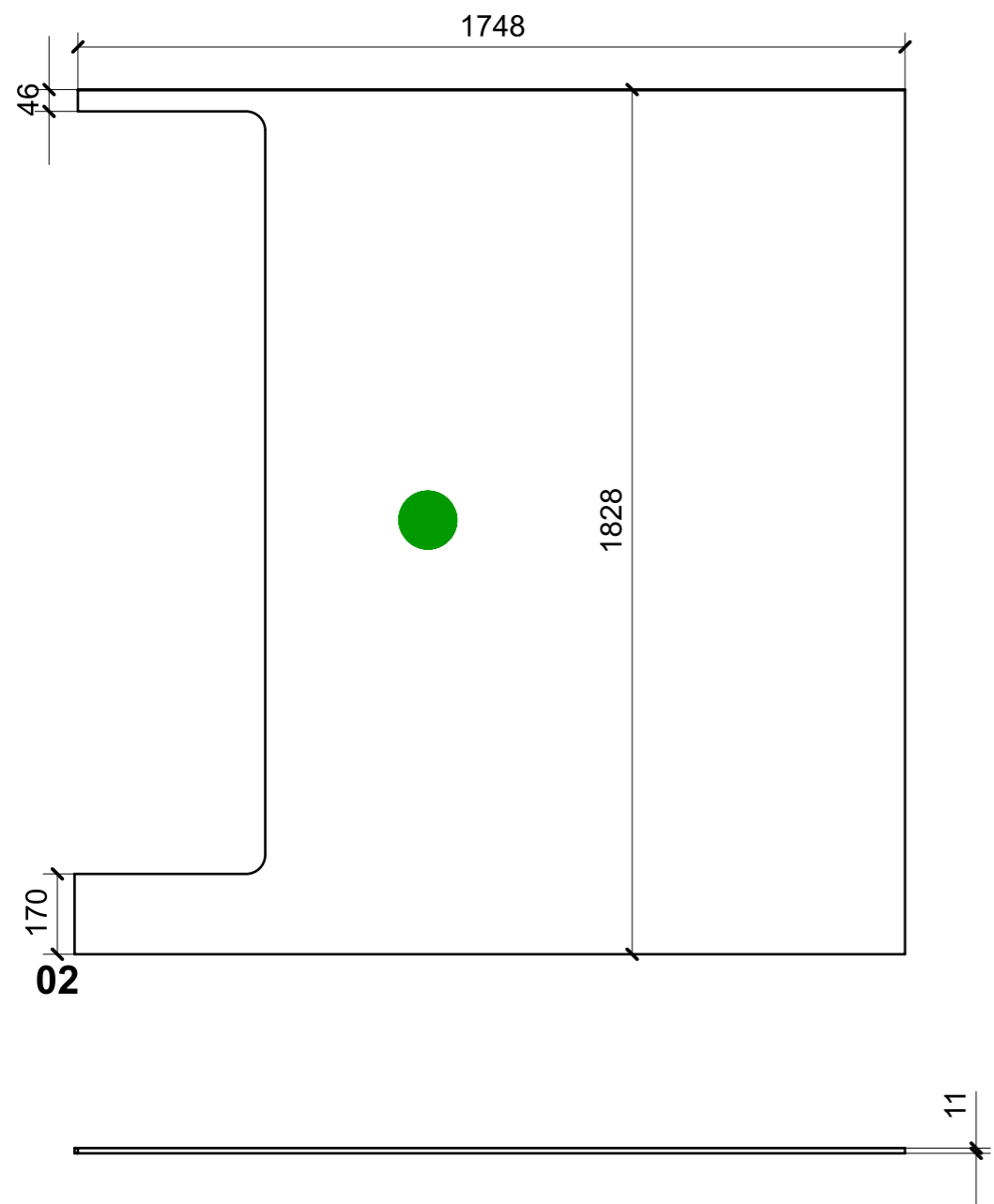

VERNICIATURA LASTRA/LACCATI:

● = VERNICIARE 1 LATO + FILI RASATI O BORDATI

NESSUN SIMBOLO = VERNICIARE 2 LATI + FILI RASATI O BORDATI

| LOCALE | CODICE | DESCRIZIONE COMPONENTE | FINITURA | GR |
|---------------|-----------------|------------------------|---------------|----|
| CABINA VIP SX | MD320_R02_VVI01 | ARMADIO | LASTRA CHIARA | 2 |

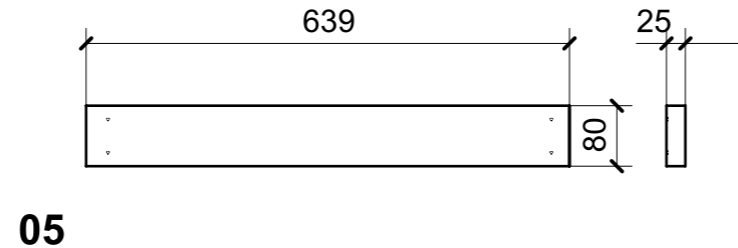
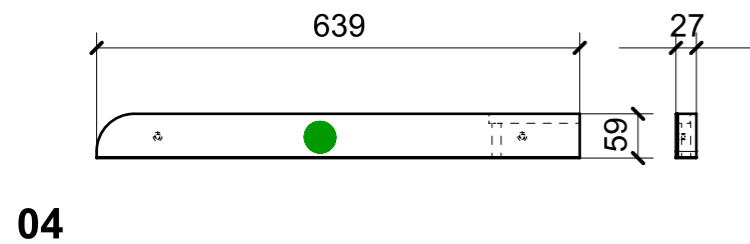
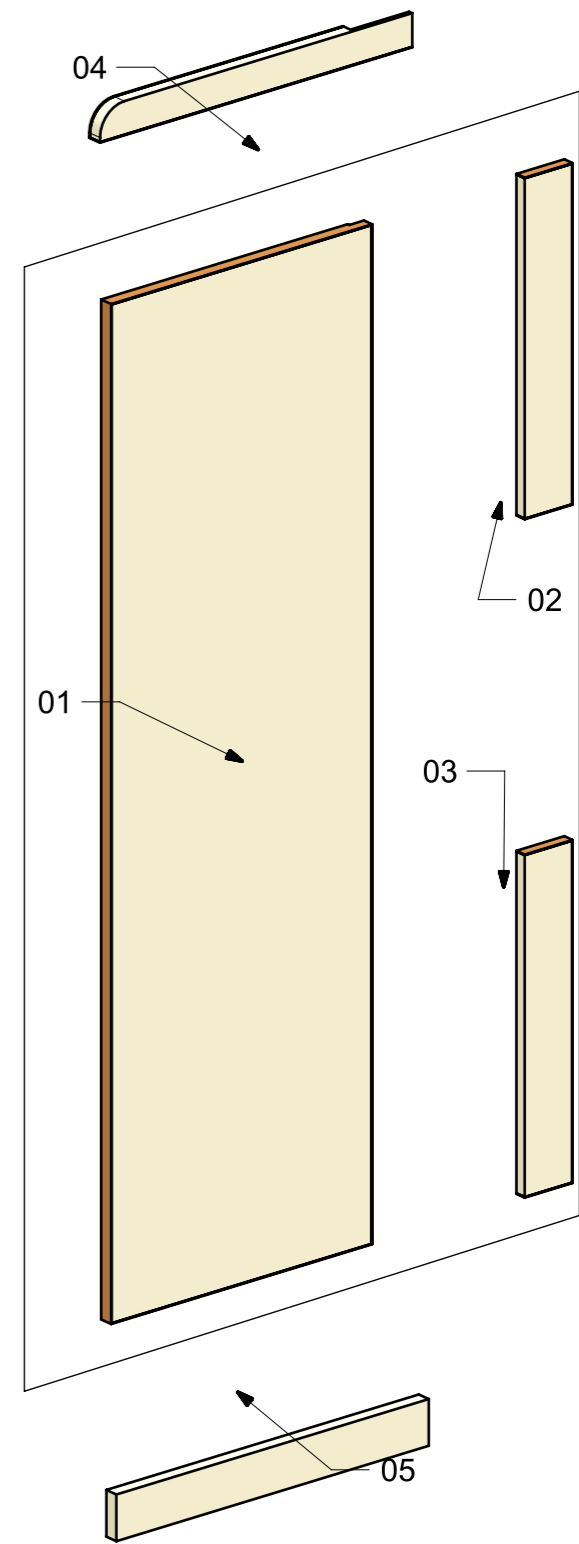
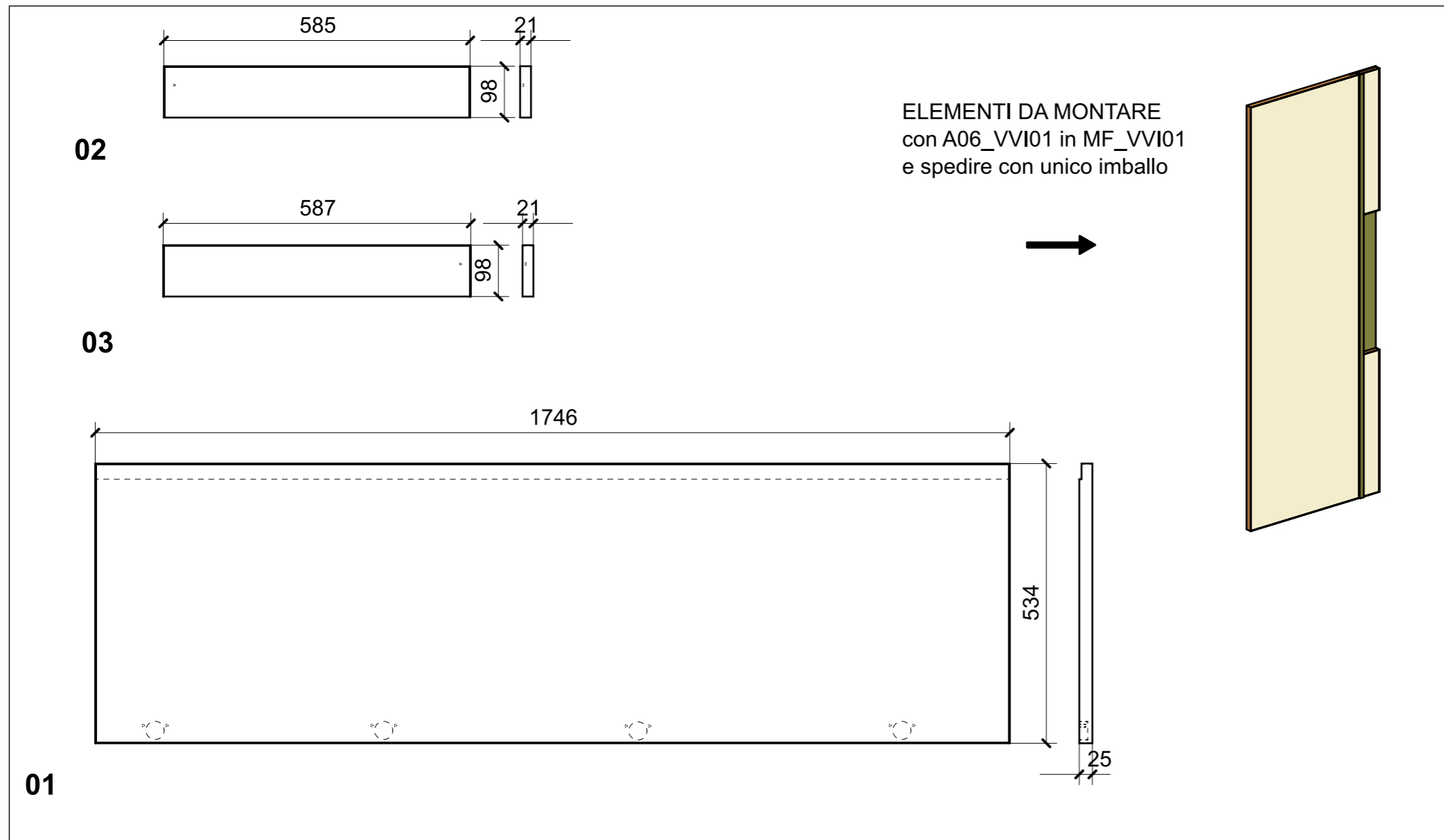

| FERRAMENTA | QTY |
|---|-----|
| MAGNETE FORZA MAGNETICA1-5 10KG_HAFELE_246.87.112 | 2 |
| BUSSOLA 6MA X 10 FORO DIAM.8 | 2 |

VERNICIATURA LASTRA/LACCATI:

● = VERNICIARE 1 LATO + FILI RASATI O BORDATI

NESSUN SIMBOLO = VERNICIARE 2 LATI + FILI RASATI O BORDATI

| LOCALE | CODICE | DESCRIZIONE COMPONENTE | FINITURA | Q.TA |
|---------------|-----------------|------------------------|---------------|------|
| CABINA VIP SX | MD320_R02_VVL01 | PLENUM ARMADIO | LASTRA CHIARA | PTP |

