

LOCALE	CODICE	DESCRIZIONE COMPONENTE	FINITURA	GR.
CABINA OSPITI SX	MD320_L01_LC01	STRUTTURA MURATA	LACCATO BRONZO	2

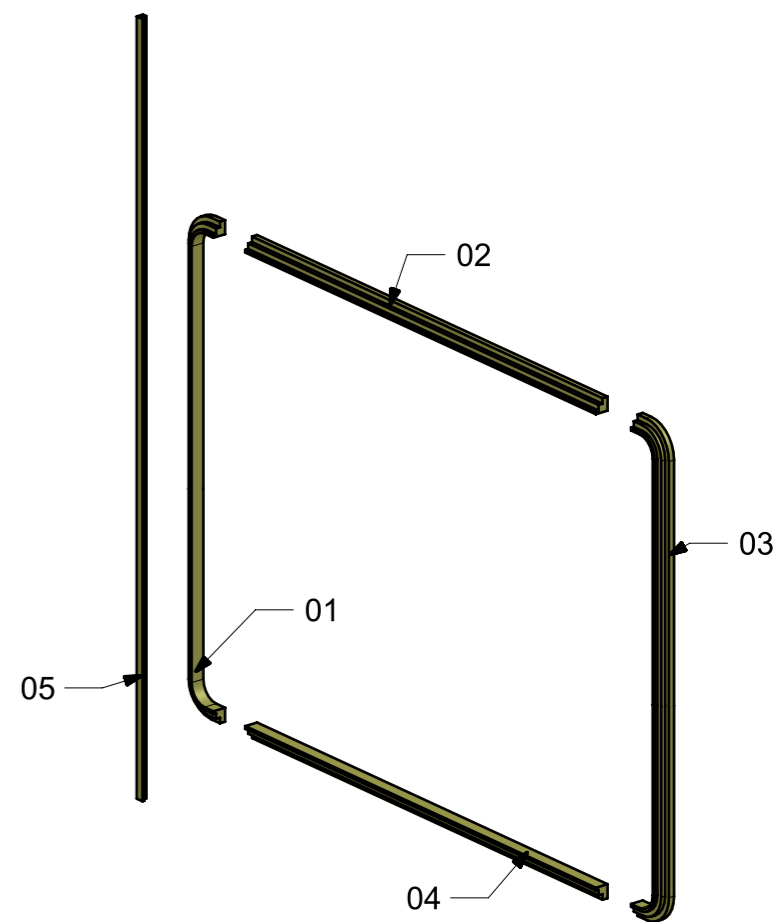

LOCALE	CODICE	DESCRIZIONE COMPONENTE	FINITURA	GR.
CABINA OSPITI SX	MD320_L01_LD01	PLENUM MURATA	LACCATO BRONZO SPAZZOLATO	PTP

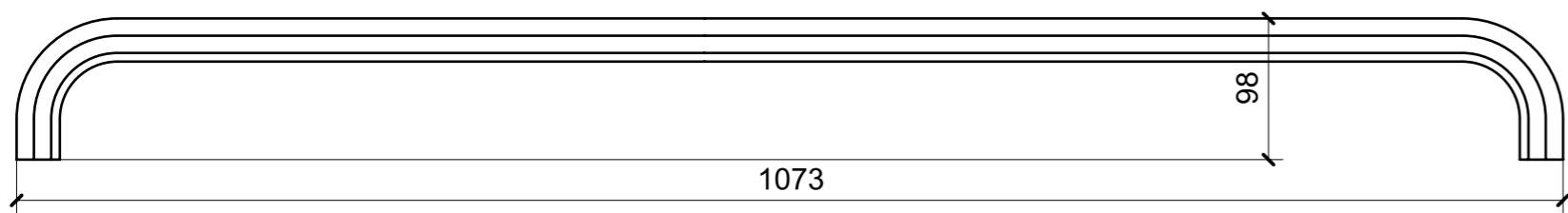
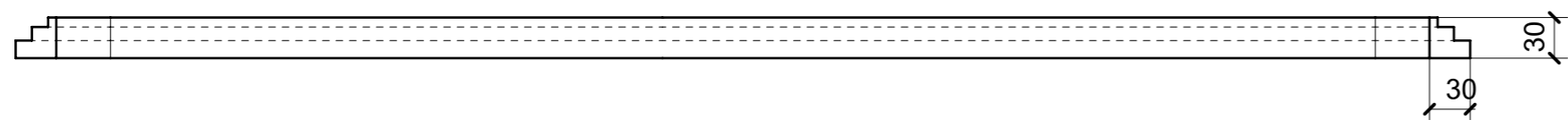
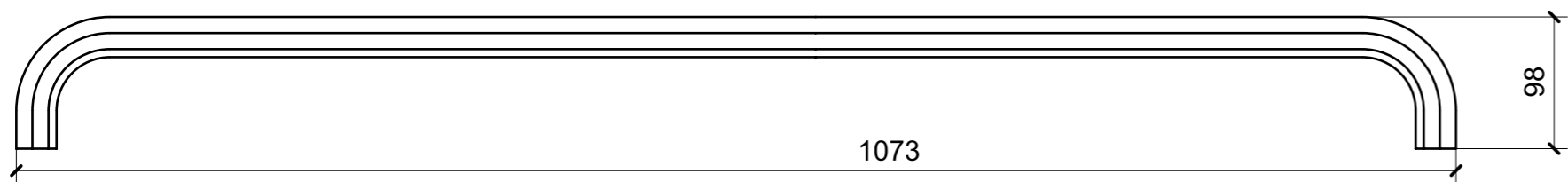
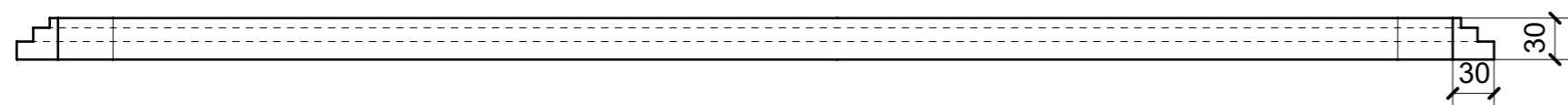
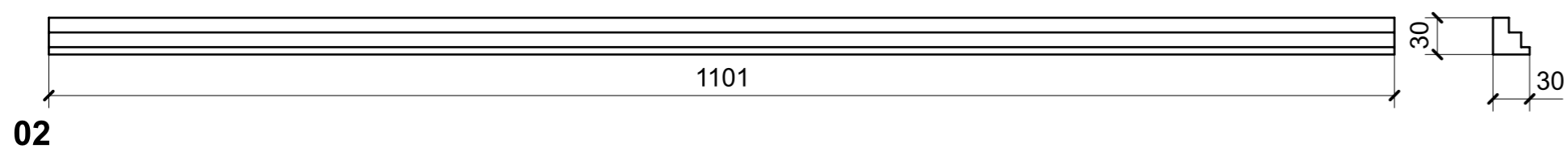
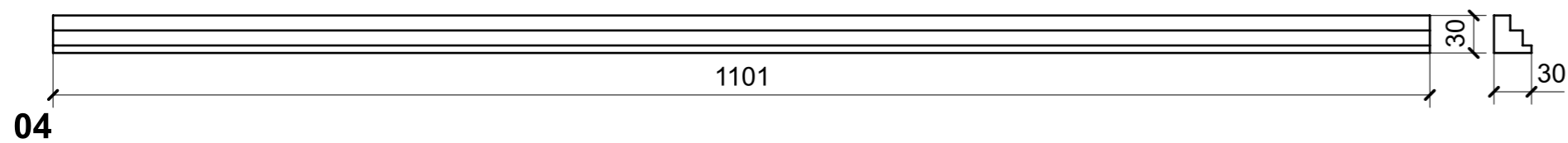
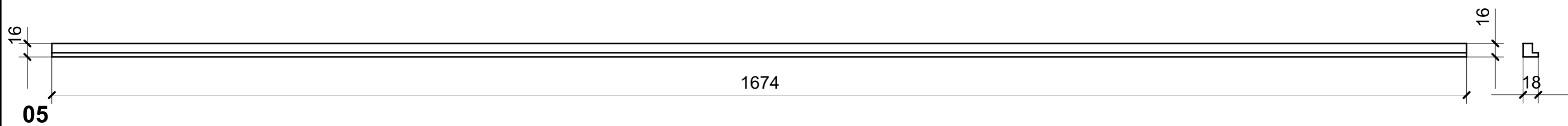
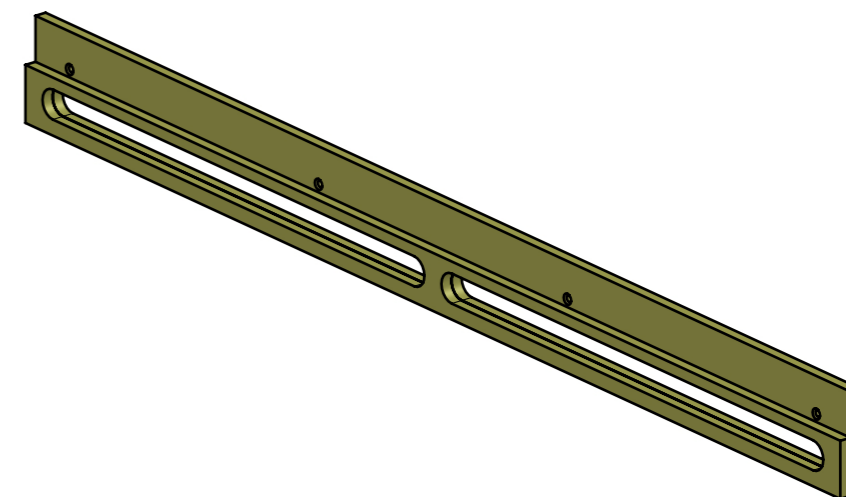
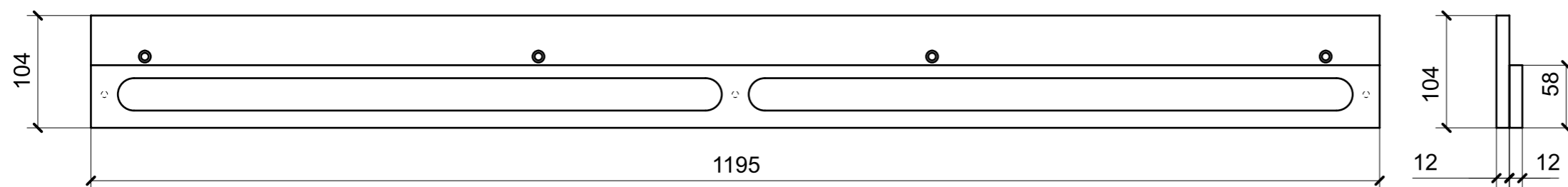

LOCALE	CODICE	DESCRIZIONE COMPONENTE	FINITURA	GR.
CABINA OSPITI SX	MD320_L01_LE01	STRUTTURA TESTATA LETTO	LACCATO BRONZO SPAZZOLATO	2

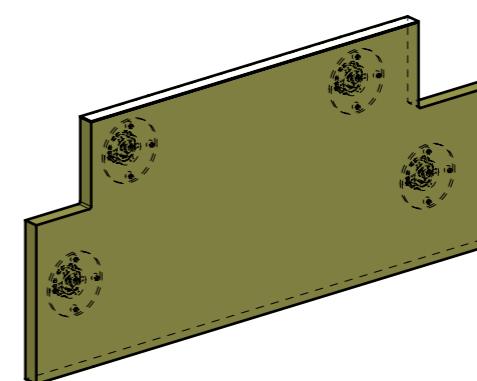

FERRAMENTA	QTY
FITLOCK M_MASCHERPA_3MM_6020202101	4

VERNICIATURA LASTRA/LACCATI:

● = VERNICIARE 1 LATO + FILI RASATI O BORDATI

NESSUN SIMBOLO = VERNICIARE 2 LATI + FILI RASATI O BORDATI

LOCALE	CODICE	DESCRIZIONE COMPONENTE	FINITURA	GR.
CABINA OSPITI SX	MD320_L01_LG01	LETTO MURATA	LACCATO BRONZO SPAZZOLATO	2

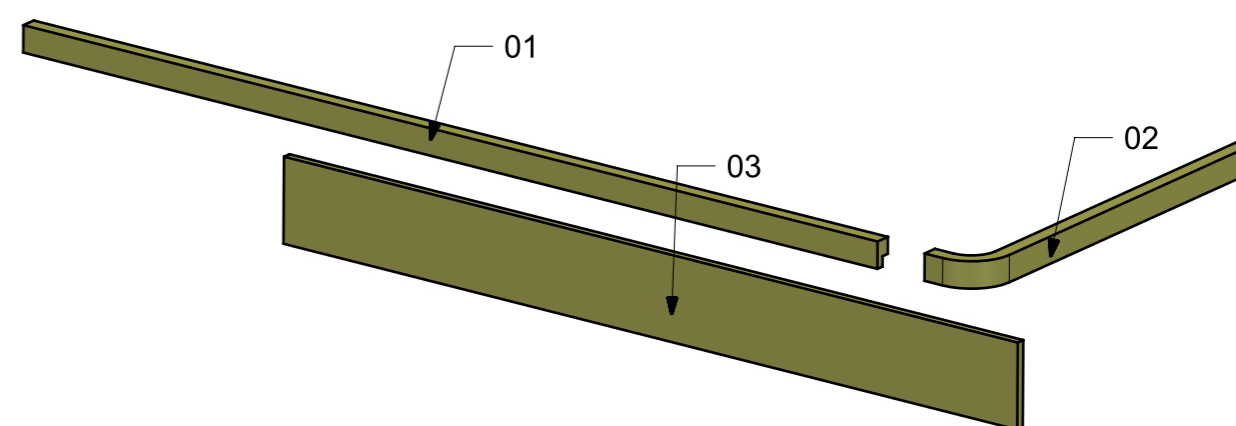
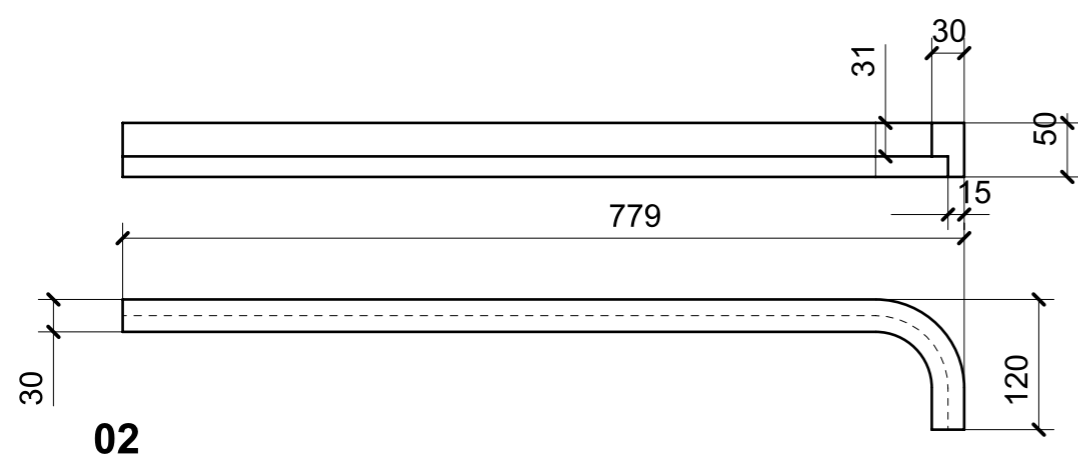
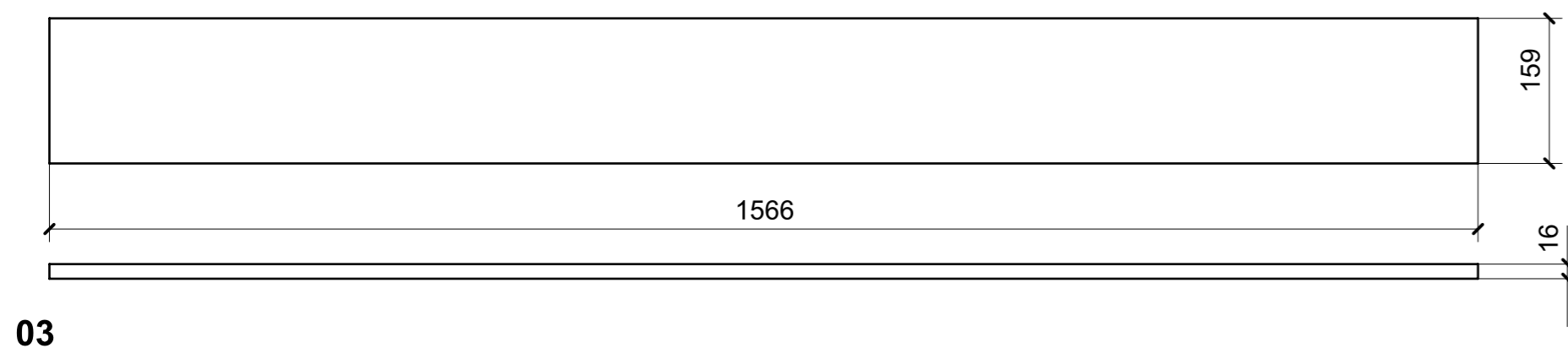
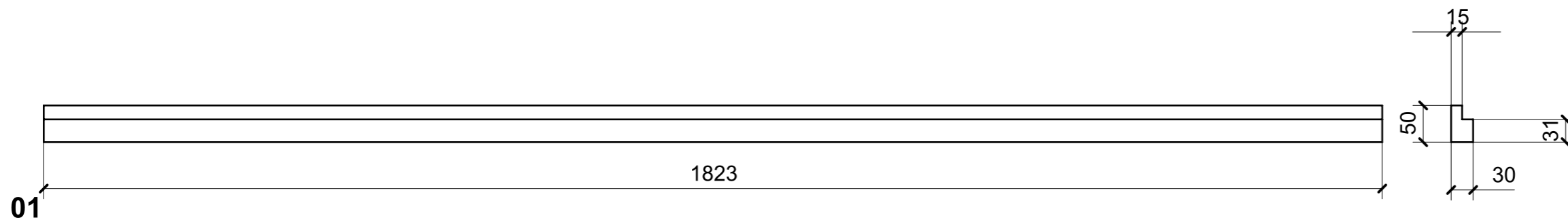

VERNICIATURA LASTRA/LACCATI:

● = VERNICIARE 1 LATO + FILI RASATI O BORDATI

NESSUN SIMBOLO = VERNICIARE 2 LATI + FILI RASATI O BORDATI

LOCALE	CODICE	DESCRIZIONE COMPONENTE	FINITURA	GR.
CABINA OSPITI SX	MD320_L01_LH01	LETTO CENTRO BARCA	LACCATO BRONZO	2

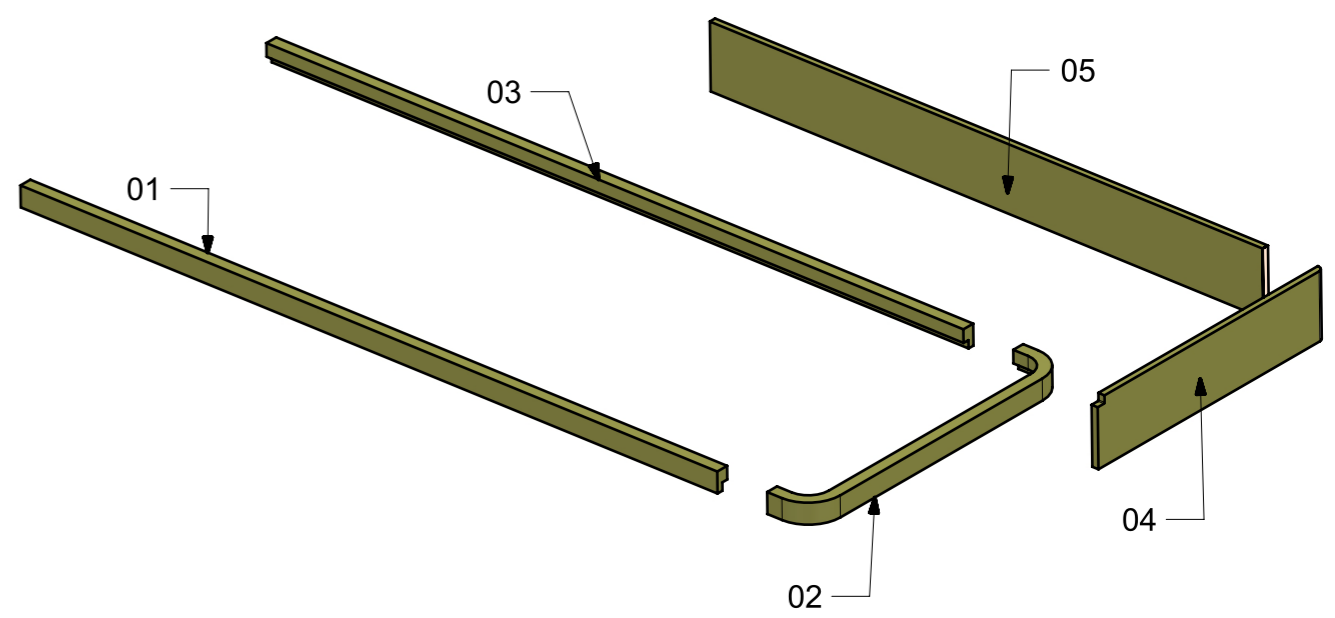
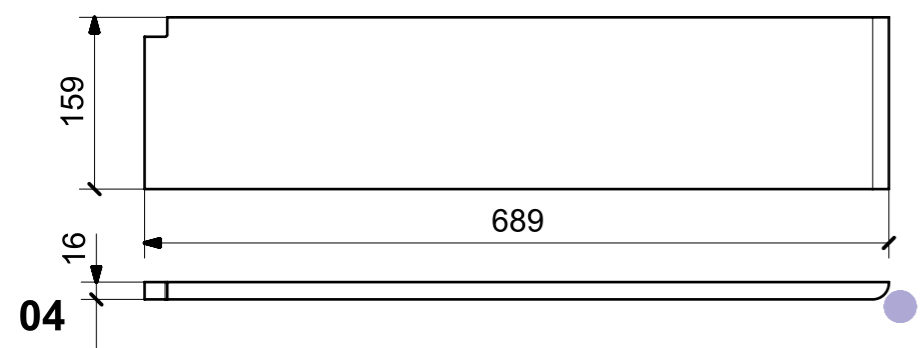
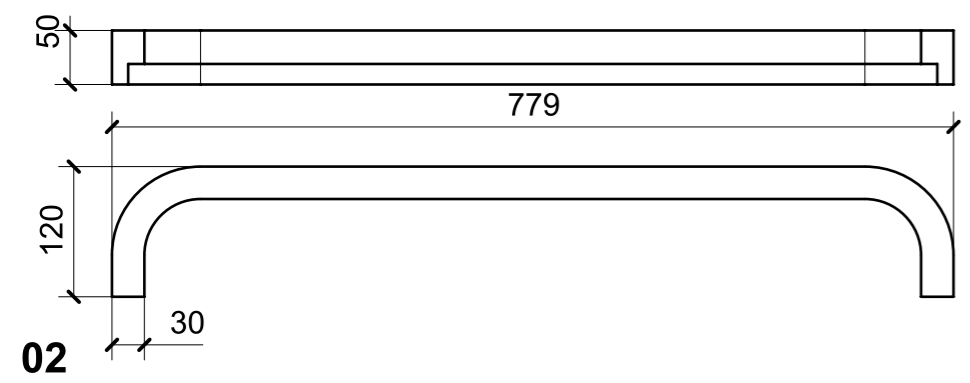
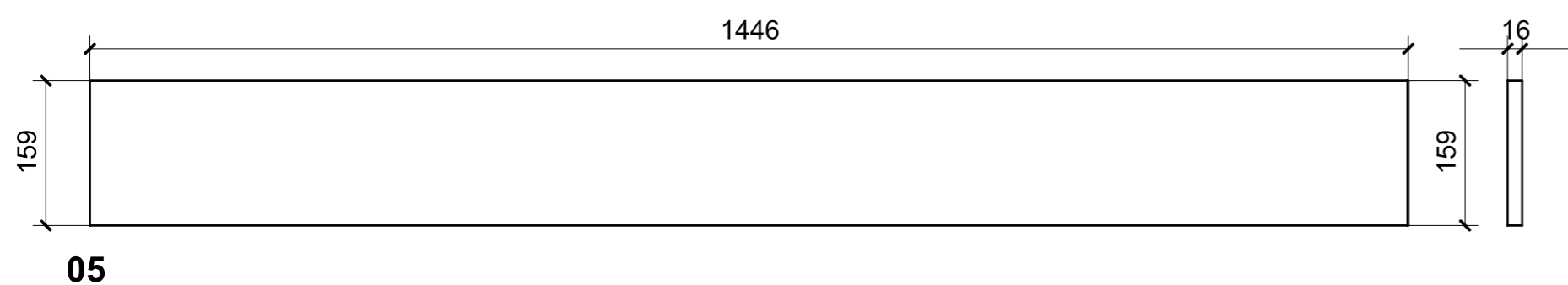
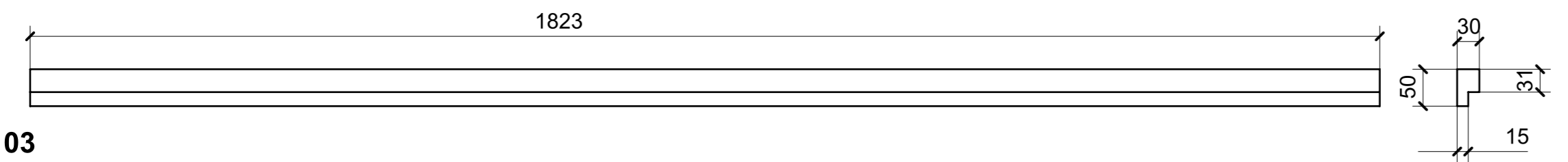
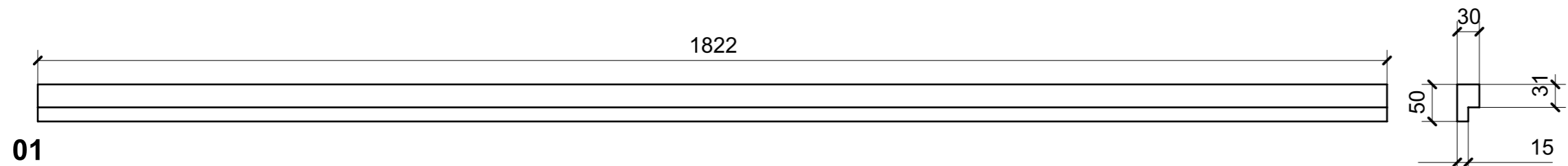

● = FILI RASATI
 ● = VERNICIARE 1 LATO + FILI RASATI O BORDATI
 NESSUN SIMBOLO = VERNICIARE 2 LATI + FILI RASATI O BORDATI

LOCALE	CODICE	DESCRIZIONE COMPONENTE	FINITURA	GR.
CABINA OSPITI SX	MD320_L01_LI01	COMODINO	LACCATO BRONZO SPAZZOLATO	2

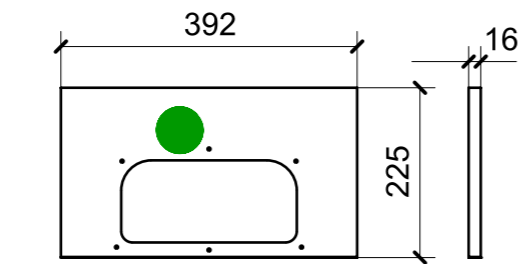
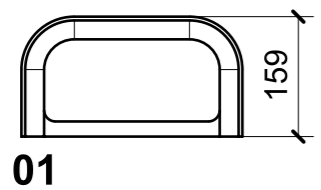
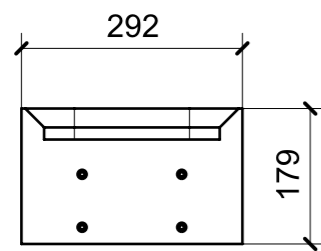

02
ELEMENTI DA MONTARE
in MG_LI01
e spedire con unico imballo

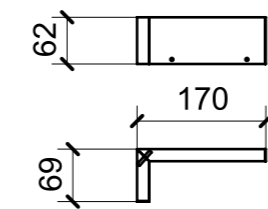
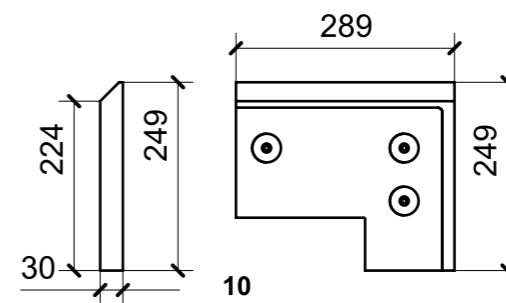
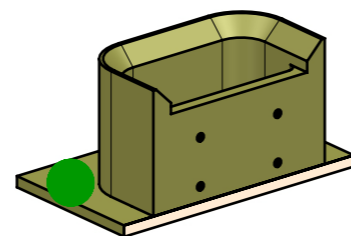

05

ELEMENTI DA MONTARE
in MG_LI03
e spedire con unico imballo

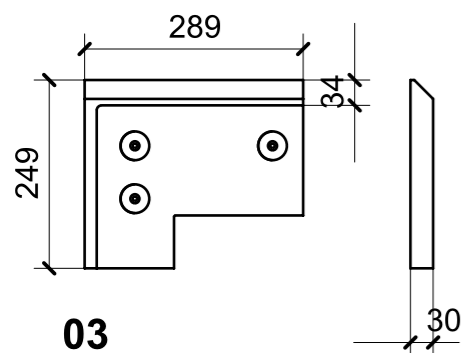
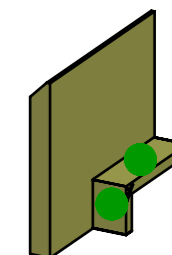

03

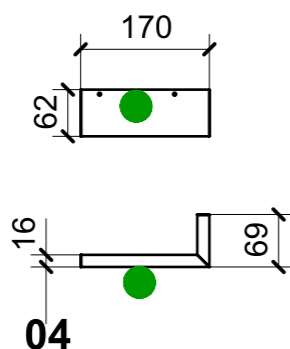

04

ELEMENTI DA MONTARE
in MG_LI02
e spedire con unico imballo

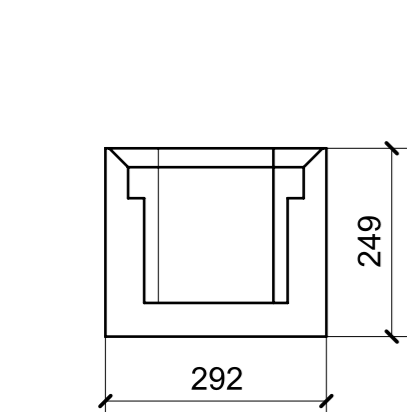
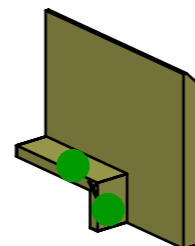

06

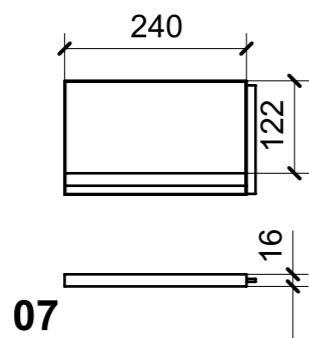

07

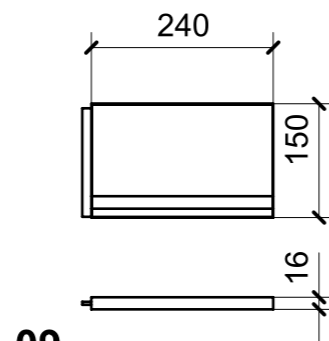

09

ELEMENTI DA MONTARE
in MF_LI03
e spedire con unico imballo

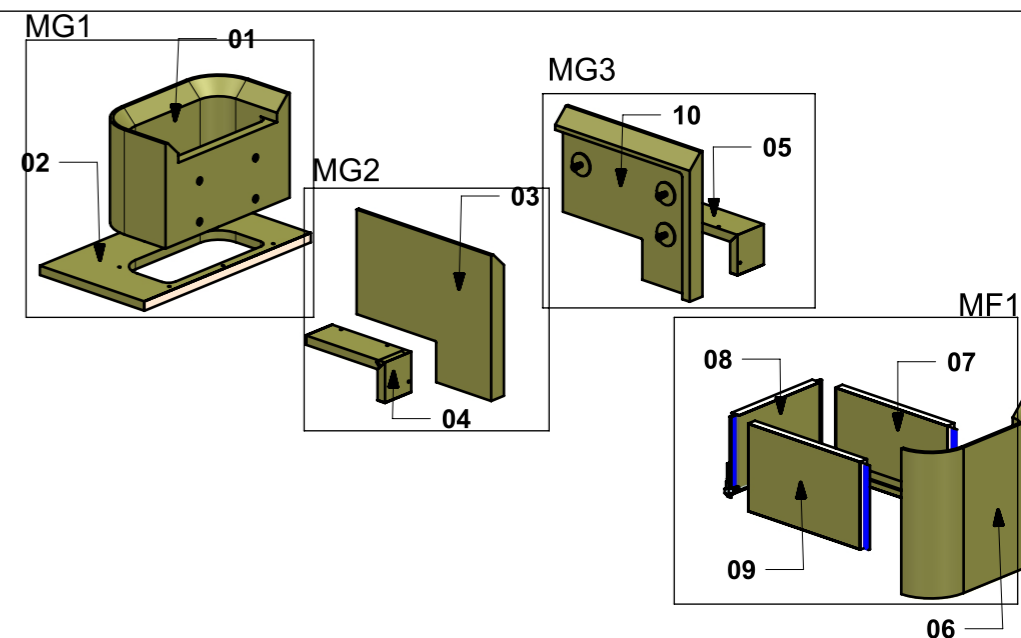
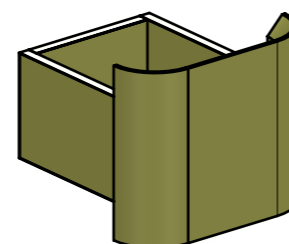

VERNICIATURA LASTRA/LACCATI:

● = FILI RASATI

● = VERNICIARE 1 LATO + FILI RASATI O BORDATI

NESSUN SIMBOLO = VERNICIARE 2 LATI + FILI RASATI O BORDATI

FERRAMENTA	QTY
GUIDA DYNAPRO FRONT LOCKING DEVICE R_FBC_F134108955 4D	1
GUIDA DYNAPRO FRONT LOCKING DEVICE L_FBC_F134108955 4D	1
GUIDA DYNAPRO ADJUSTMENT ADAPTER R_FBC_F134141746 4D	1
GUIDA DYNAPRO ADJUSTMENT ADAPTER L_FBC_F134141746 4D	1
BUSSOLA 6MA X 10 FORO DIAM.8	10

LOCALE	CODICE	DESCRIZIONE COMPONENTE	FINITURA	GR.
CABINA OSPITI SX	MD320_L01_LM01	CORNICE TV OPT	LACCATO BRONZO SPAZZOLATO	PTP

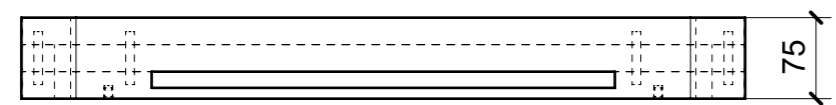
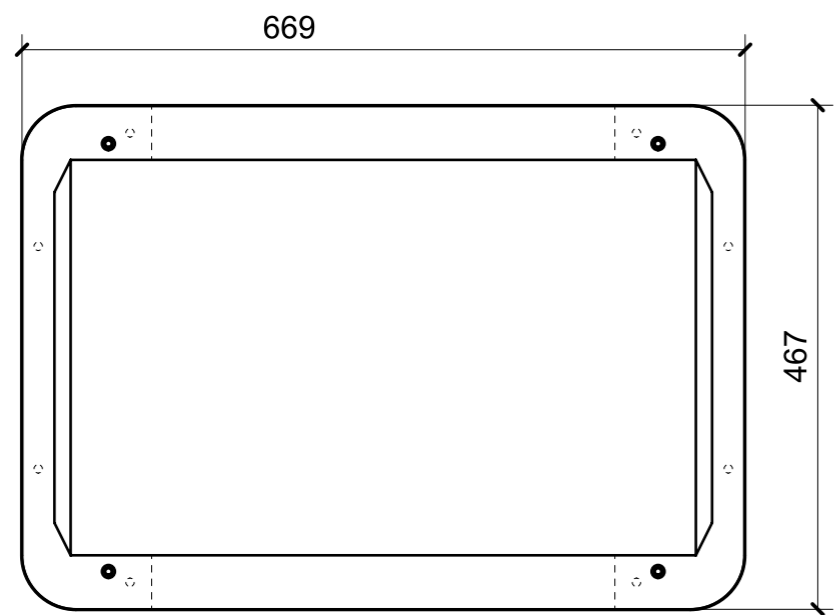

02

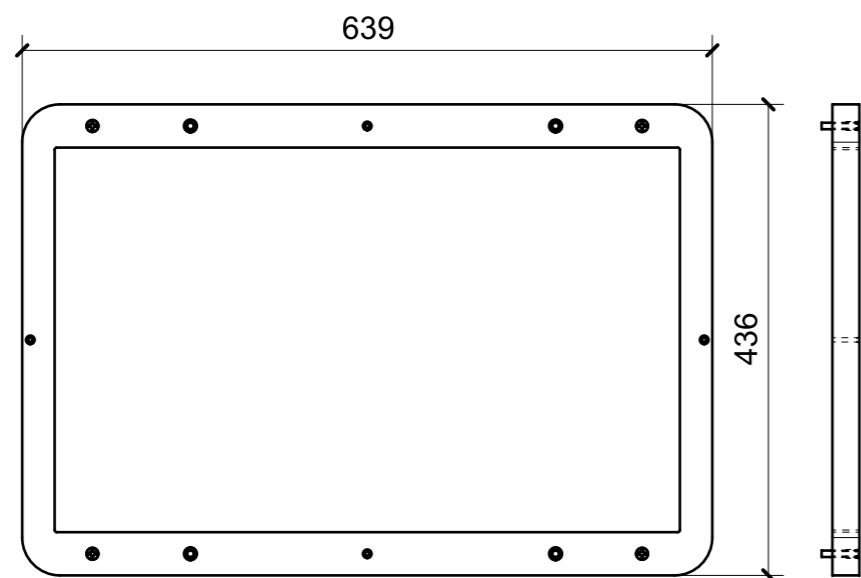

01

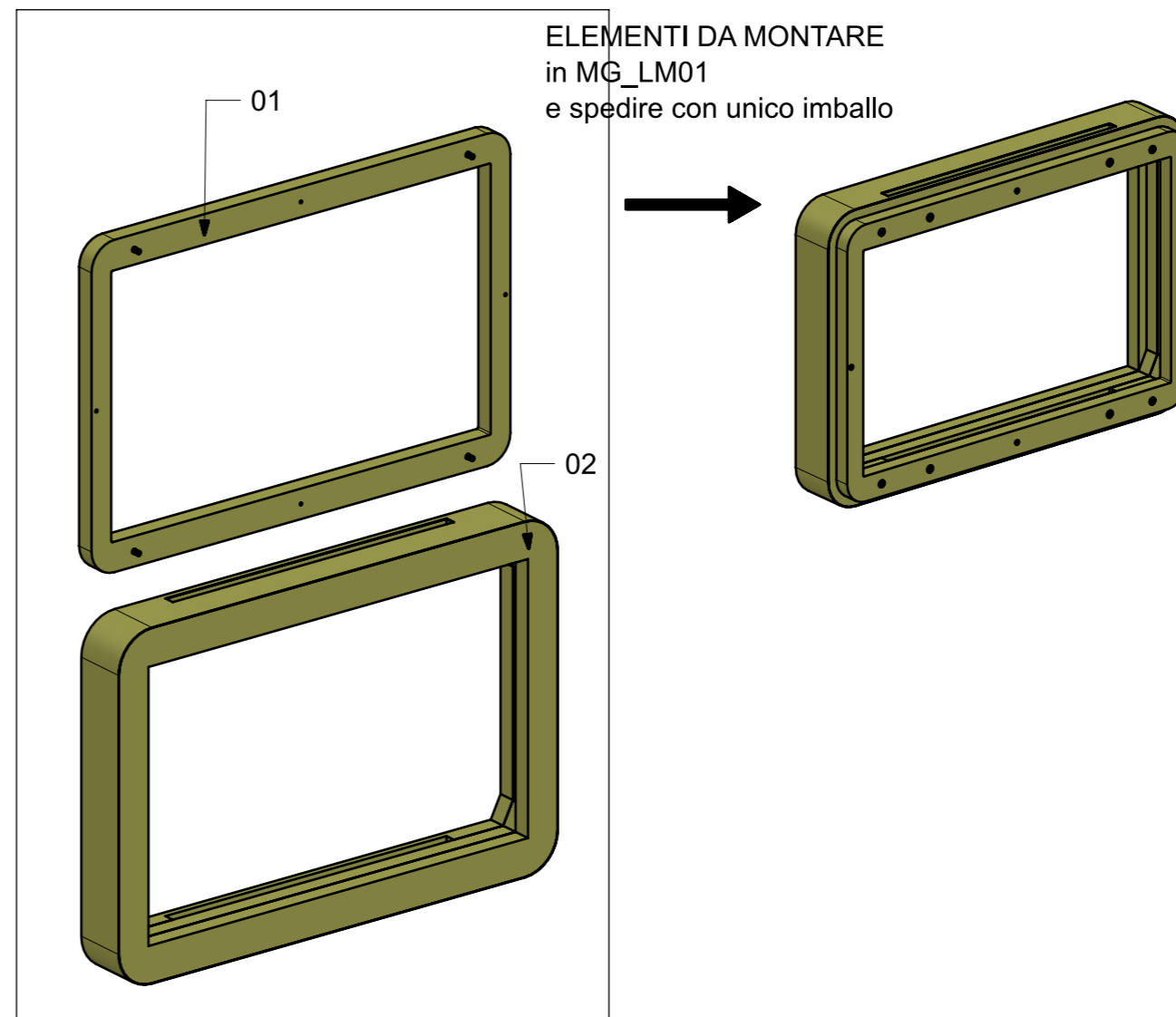

FERRAMENTA	QTY
BUSSOLA 6MA X 10 FORO DIAM.8	4
VITE 6MA X 35 TESTA SVASATA	4

VERNICIATURA LASTRA/LACCATI:

● = FILI RASATI

● = VERNICIARE 1 LATO + FILI RASATI O BORDATI

NESSUN SIMBOLO = VERNICIARE 2 LATI + FILI RASATI O BORDATI

LOCALE	CODICE	DESCRIZIONE COMPONENTE	FINITURA	GR.
CABINA OSPITI SX	MD320_L02_LN01	CIELINO	LACCATO NCS- S - 1002-Y -MANOPESCA	3

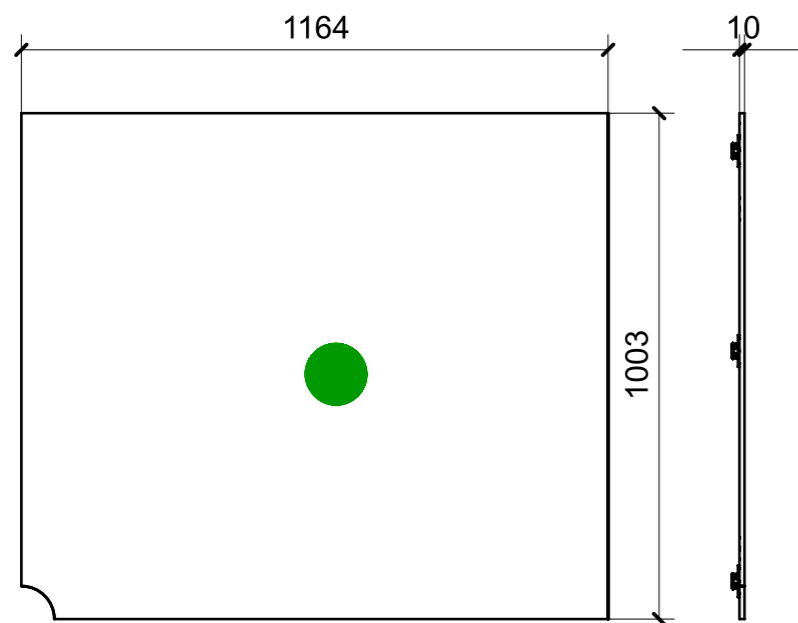

04

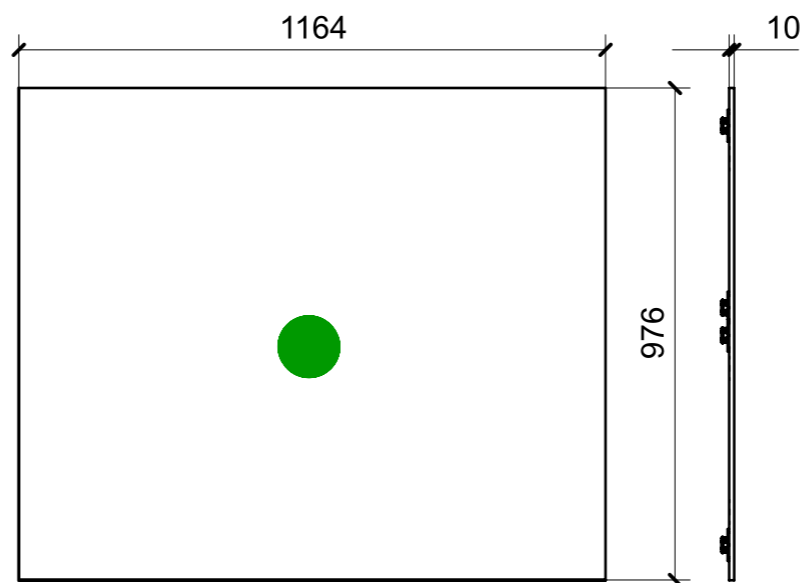

05

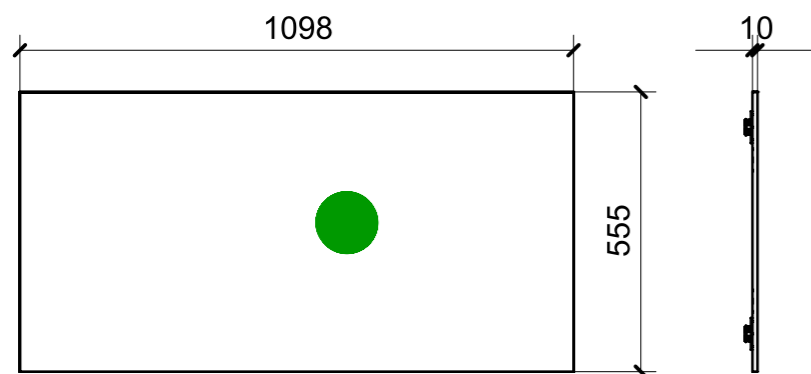

03

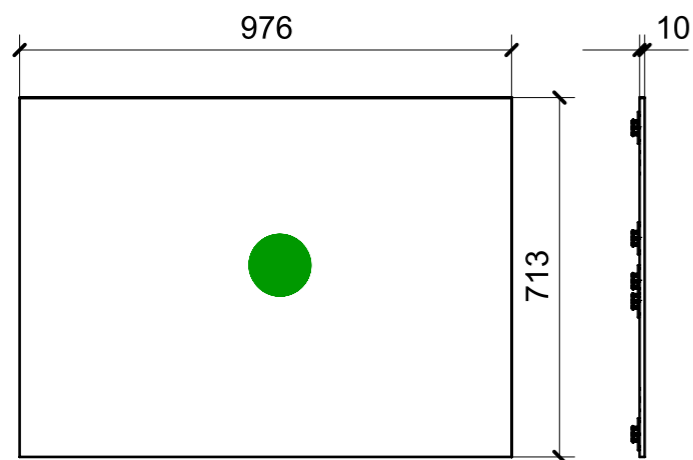

01

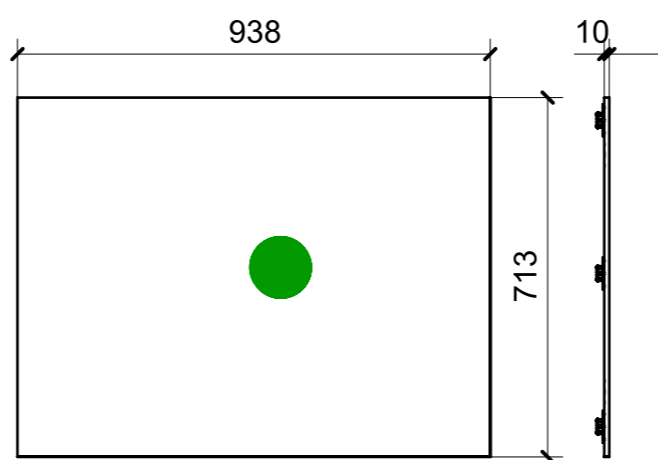

02

INCOLLARE I TONDINI AI LACCATI

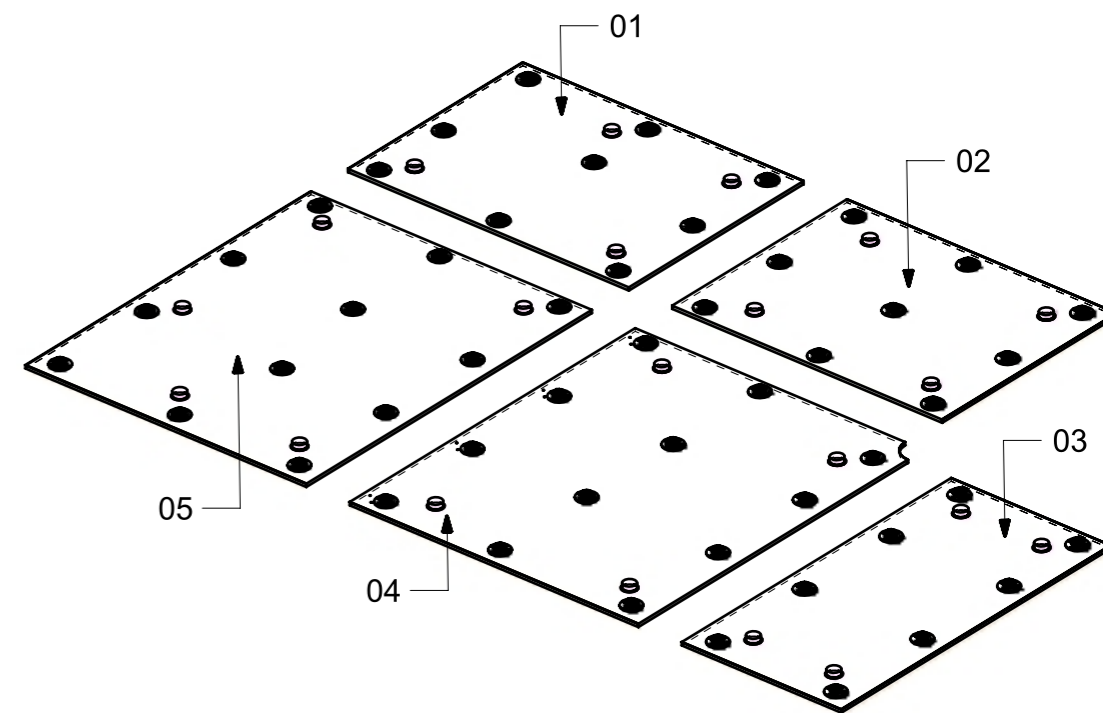

FERRAMENTA	QTY
TONDINO PER CENTRAGGIO ANTICADUTA 40X15	21
FITLOCK M_MASCHERPA_3MM_6020202101	50

VERNICIATURA LASTRA/LACCATI:

● = VERNICIARE 1 LATO + FILI RASATI O BORDATI

NESSUN SIMBOLO = VERNICIARE 2 LATI + FILI RASATI O BORDATI