

LOCALE	CODICE	DESCRIZIONE COMPONENTE	FINITURA	GR.
CABINA OSPITI DX	MD320_L01_RA01	STRUTTURA MURATA TESTATA LETTO	LACCATO BRONZO SPAZZOLATO	3

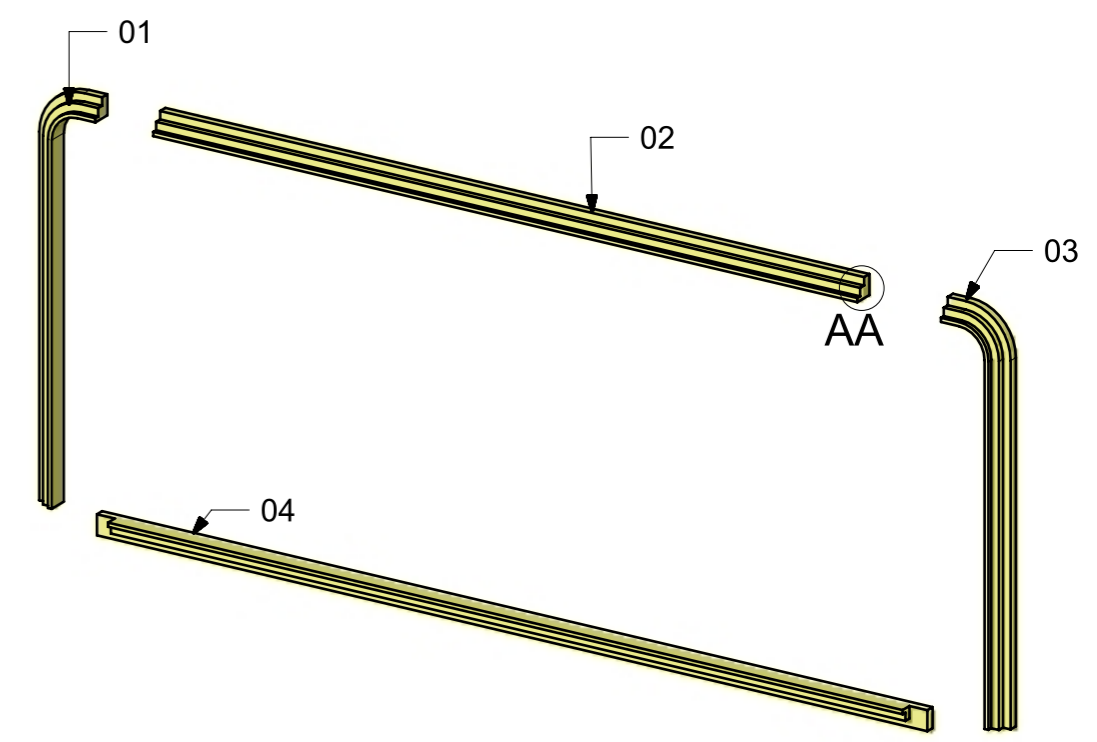
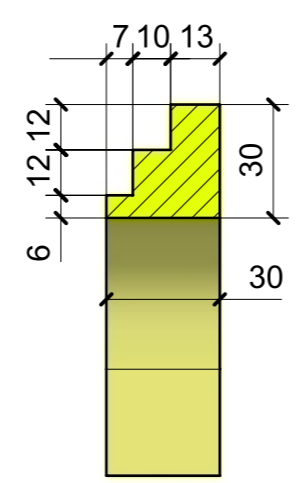
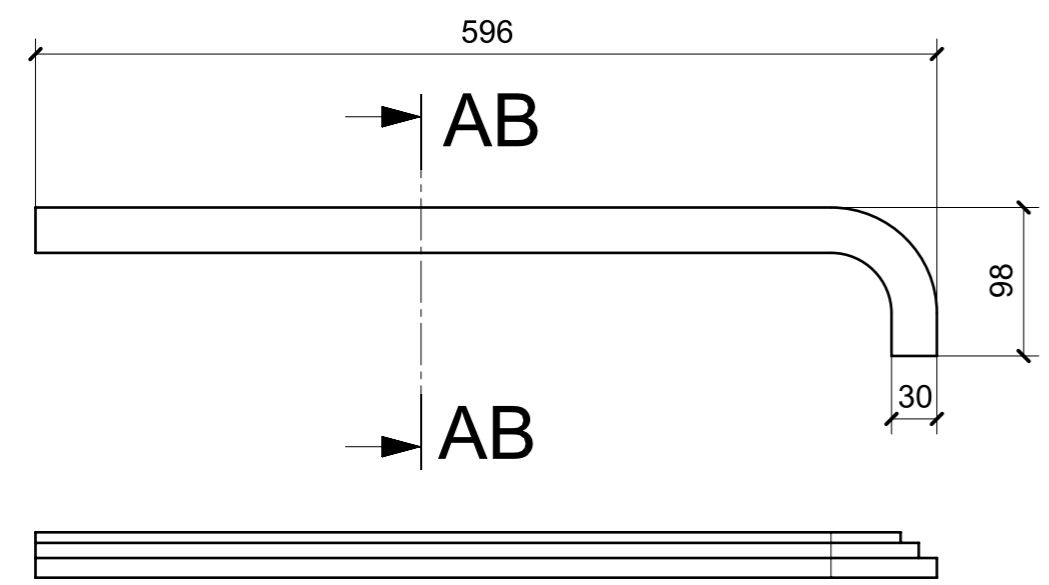
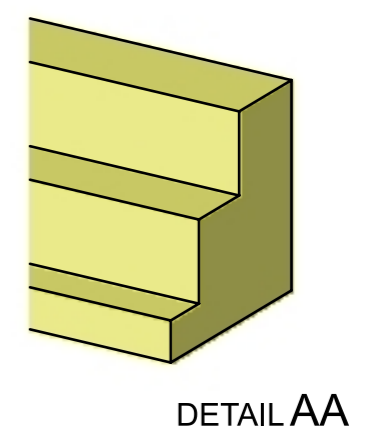
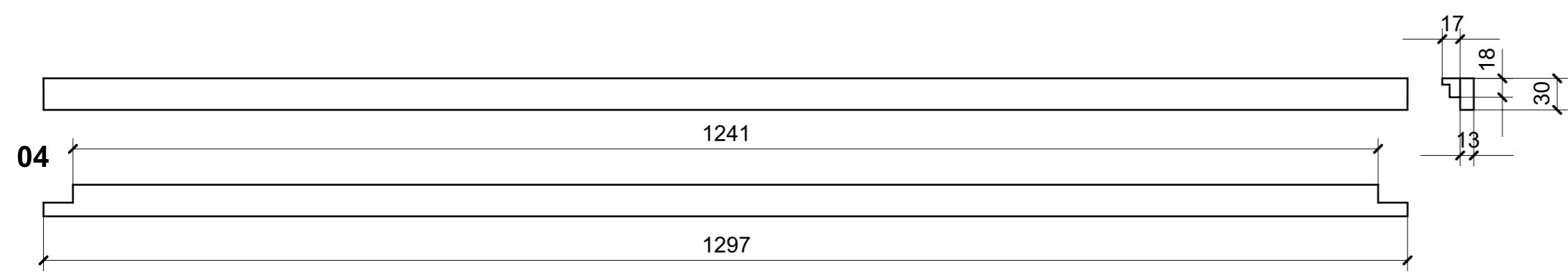
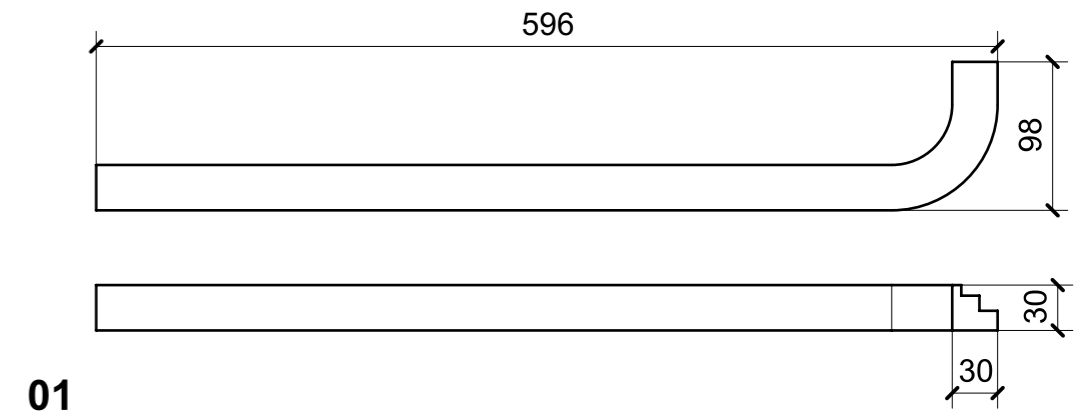
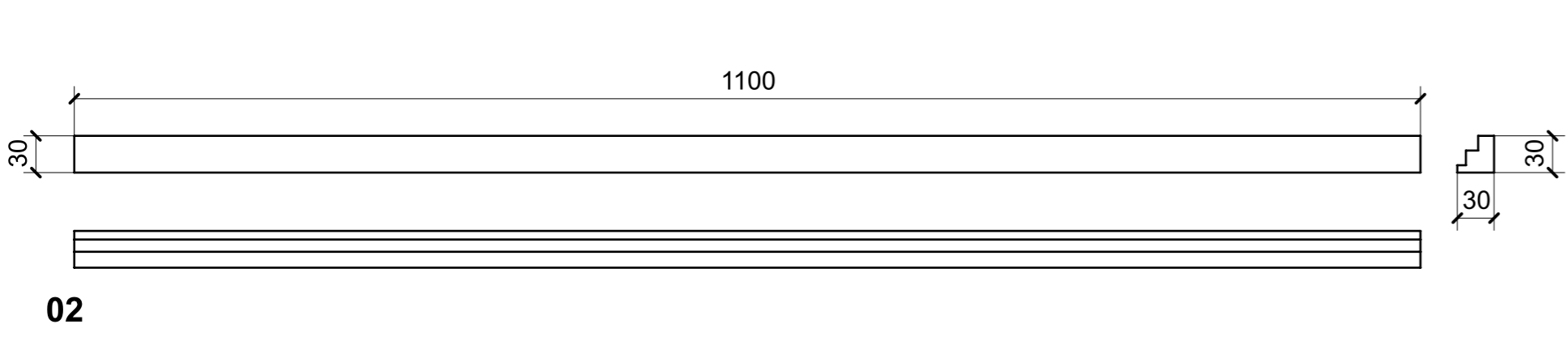

LOCALE	CODICE	DESCRIZIONE COMPONENTE	FINITURA	GR.
CABINA OSPITI DX	MD320_L01_RB01	COMODINO PRUA	LACCATO BRONZO SPAZZOLATO	2

01

02

ELEMENTI DA MONTARE
in MG_RB01
e spedire con unico imballo

03

04

05

06

07

08

09

10

11

ELEMENTI DA MONTARE
in MF_RB01
e spedire con unico imballo

FERRAMENTA	QTY
GUIDA DYNAPRO ADJUSTMENT ADAPTER L_FBC_F134141746 4D	1
GUIDA DYNAPRO FRONT LOCKING DEVICE R_FBC_F134108955 4D	1
GUIDA DYNAPRO FRONT LOCKING DEVICE L_FBC_F134108955 4D	1
GUIDA DYNAPRO ADJUSTMENT ADAPTER R_FBC_F134141746 4D	1
BUSSOLA 6MA X 10 FORO DIAM.8	10

MG_RB01

MF_RB01

VERNICIATURA LASTRA/LACCATI:

● = VERNICIARE 1 LATO + FILI RASATI O BORDATI

NESSUN SIMBOLO = VERNICIARE 2 LATI + FILI RASATI O BORDATI

LOCALE	CODICE	DESCRIZIONE COMPONENTE	FINITURA	GR.
CABINA OSPITI DX	MD320_L01_RC01	STRUTTURA LETTO VAR.1	LACCATO BRONZO	2

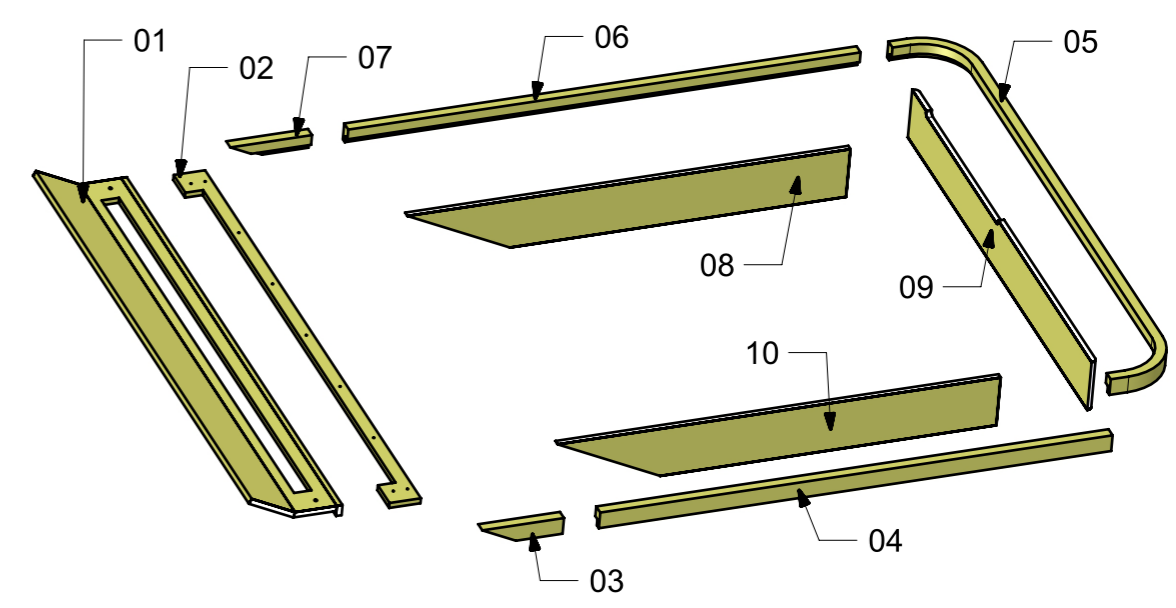
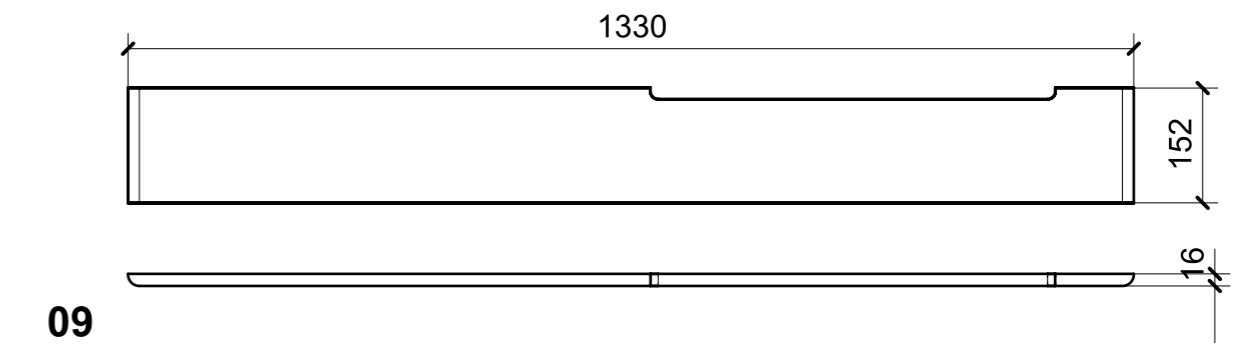
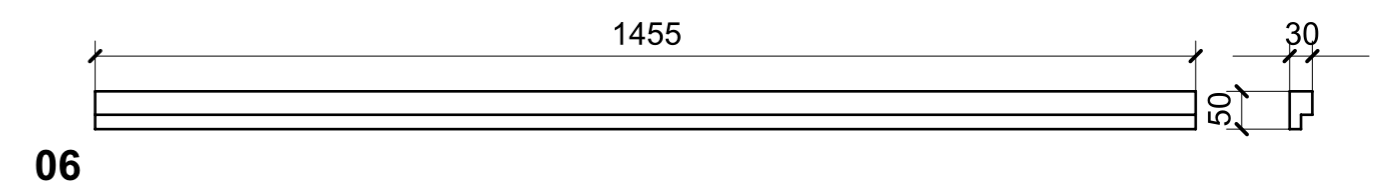
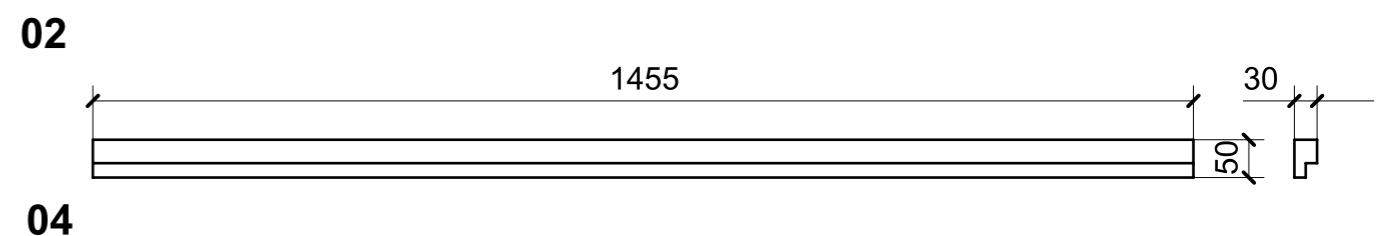
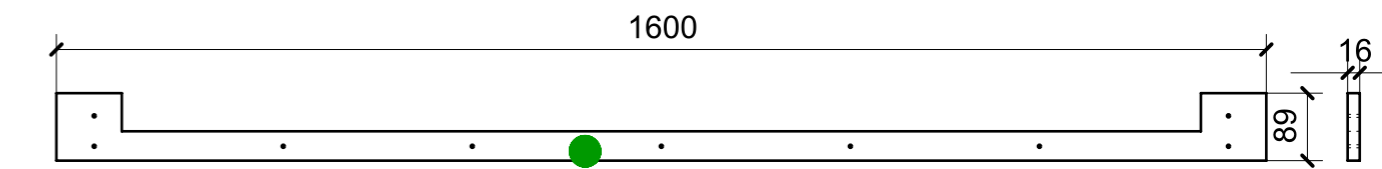
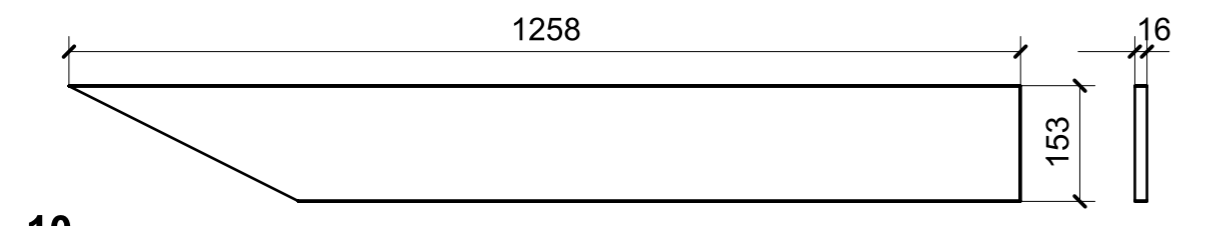
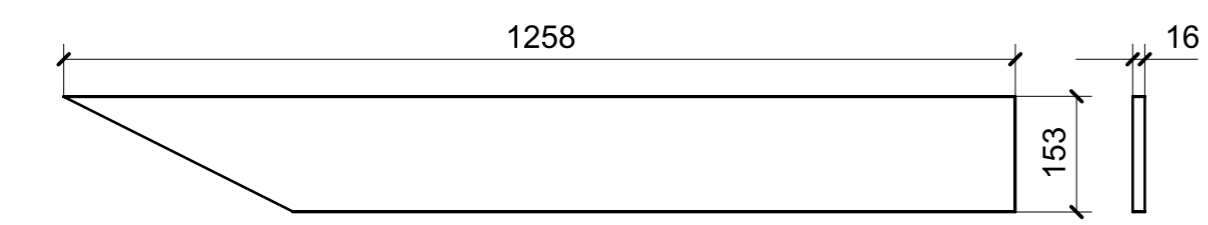
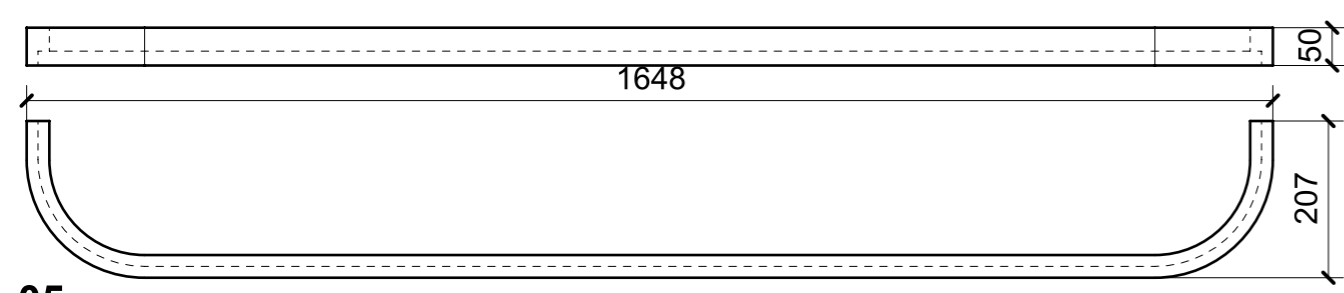
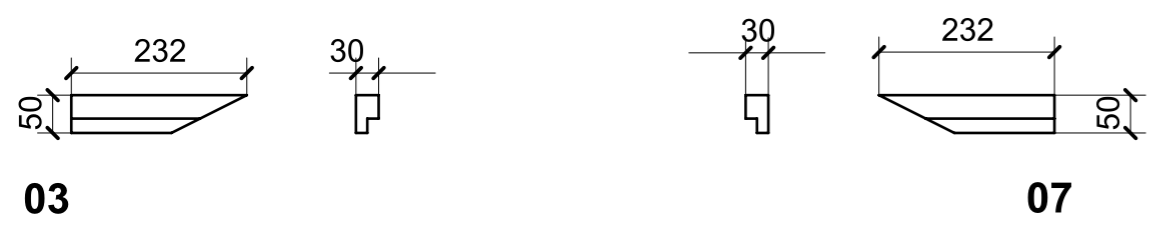

VERNICIATURA LASTRA/LACCATI:
 ● = VERNICIARE 1 LATO + FILI RASATI O BORDATI NESSUN SIMBOLO = VERNICIARE 2 LATI + FILI RASATI O BORDATI

LOCALE	CODICE	DESCRIZIONE COMPONENTE	FINITURA	GR.
CABINA OSPITI DX	MD320_L01_RRC01	LETTI SCORREVOLI VAR.2	LACCATO BRONZO	2

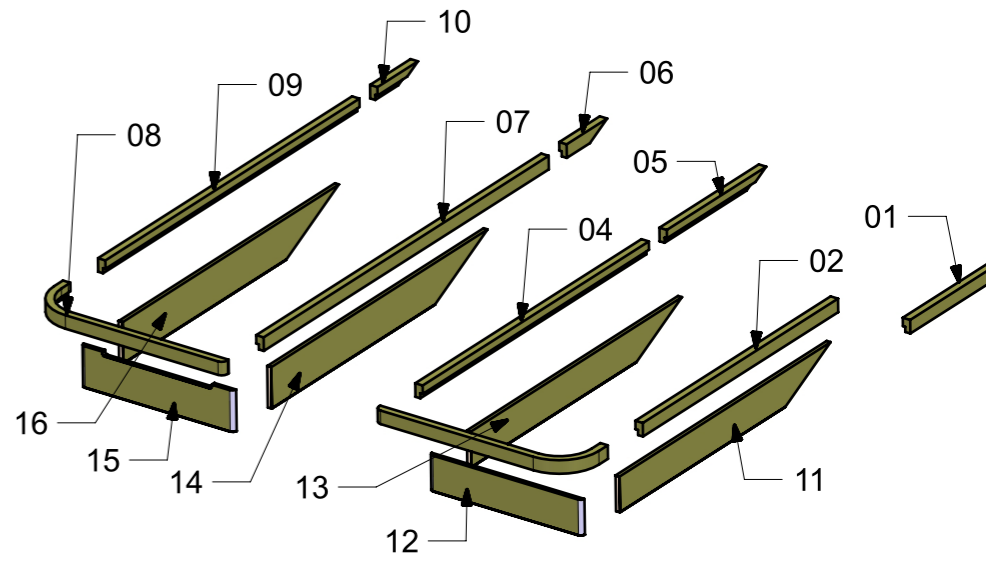
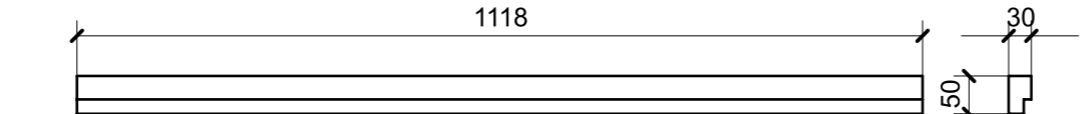
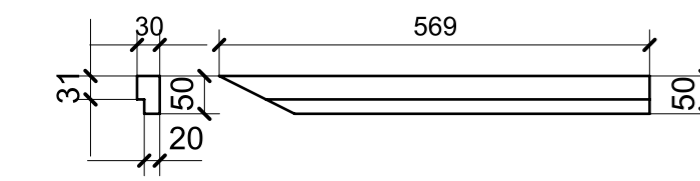
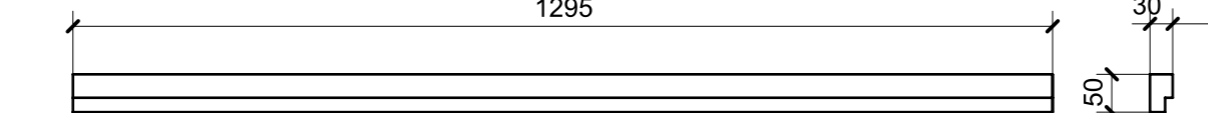
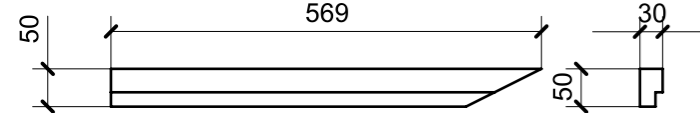
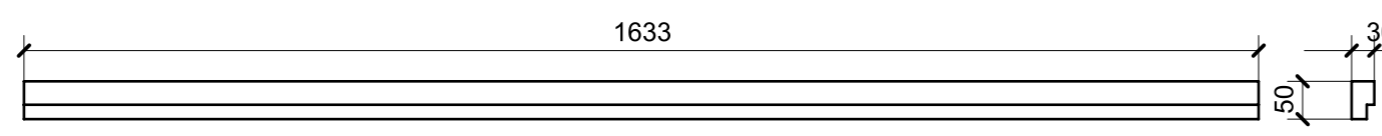
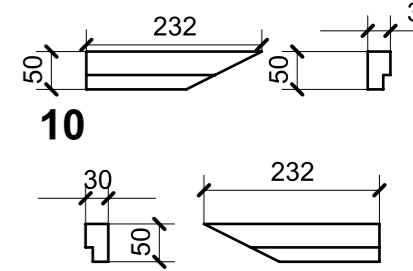
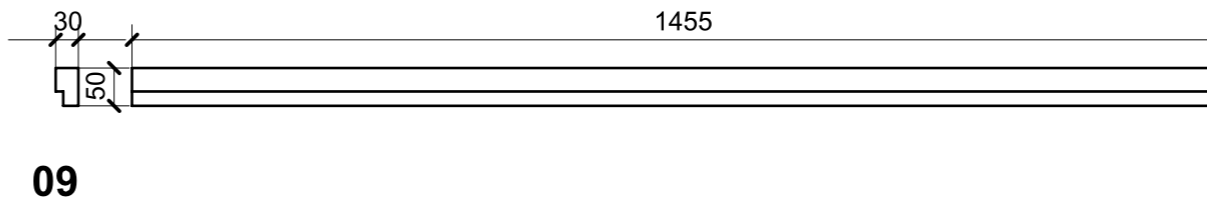
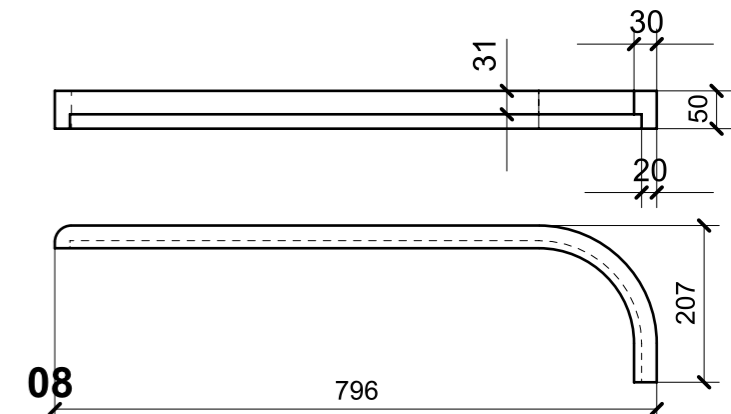
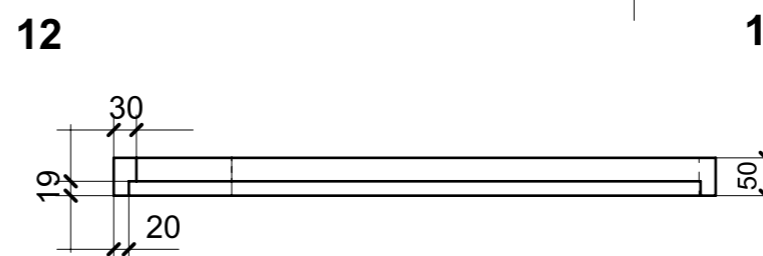
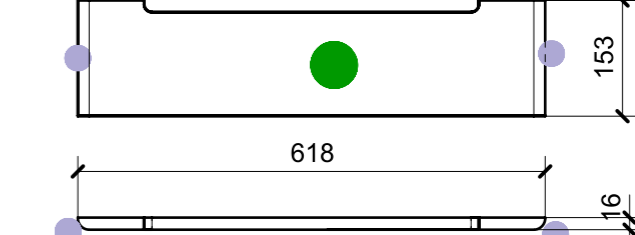
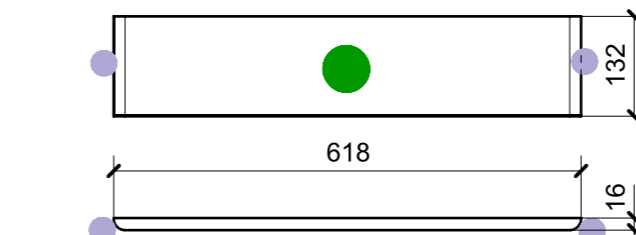
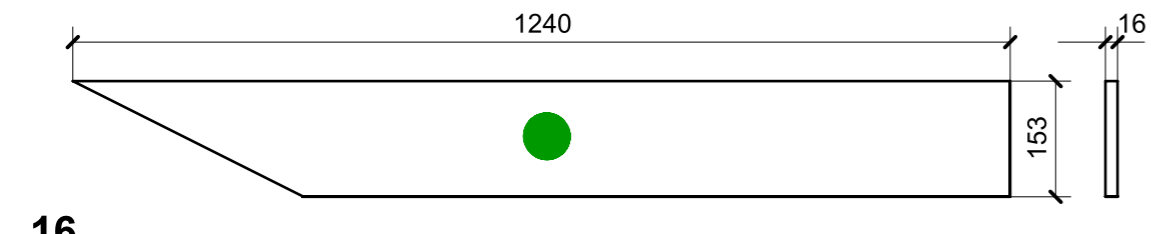
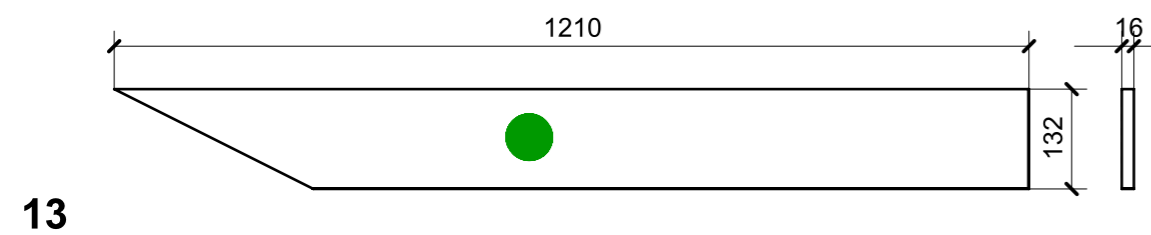
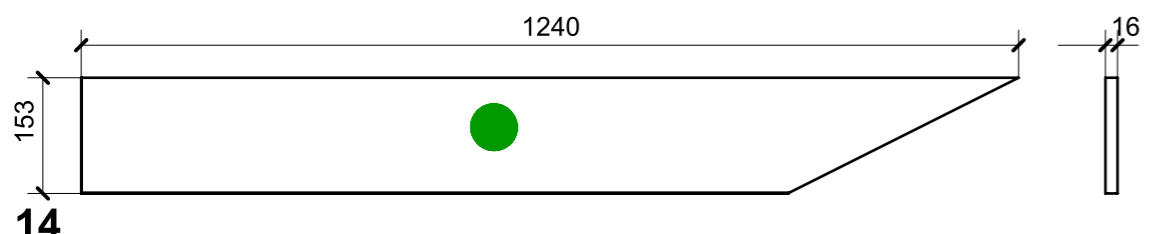
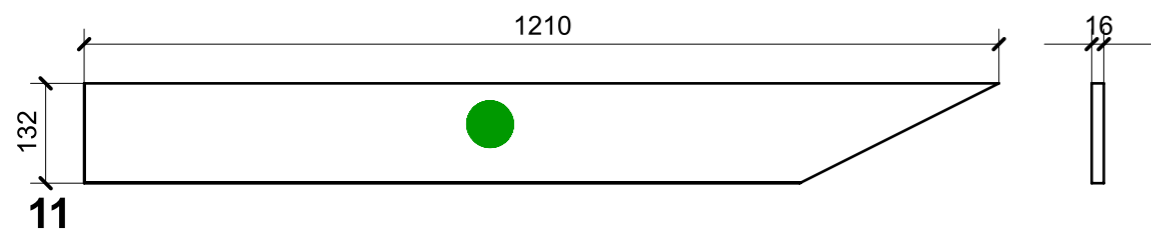

01

02

07

09

06

03

08

11

12

15

14

13

16

VERNICIATURA LASTRA/LACCATI:

● = FILI RASATI

● = VERNICIARE 1 LATO + FILI RASATI O BORDATI

NESSUN SIMBOLO = VERNICIARE 2 LATI + FILI RASATI O BORDATI

LOCALE	CODICE	DESCRIZIONE COMPONENTE	FINITURA	GR.
CABINA OSPITI DX	MD320_L01_RD01	COMODINO POPPA VAR.1	LACCATO BRONZO	2

04

03

ELEMENTI DA MONTARE
in MG_RD02
e spedire con unico imballo

05

06

ELEMENTI DA MONTARE
in MG_RD03
e spedire con unico imballo

07

08

09

10

ELEMENTI DA MONTARE
in MF_RD01
e spedire con unico imballo

11

MG_RD01

MG_RD02

MG_RD03

MF_RD01

01

02

ELEMENTI DA MONTARE
in MG_RD01
e spedire con unico imballo

VERNICIATURA LASTRA/LACCATI:
● = VERNICIARE 1 LATO + FILI RASATI O BORDATI NESSUN SIMBOLO = VERNICIARE 2 LATI + FILI RASATI O BORDATI

LOCALE	CODICE	DESCRIZIONE COMPONENTE	FINITURA	GR.
CAB. OSPITI DX	MD320_L01_RRD01	COMODINO POPPA VAR.2	LACCATO BRONZO	2

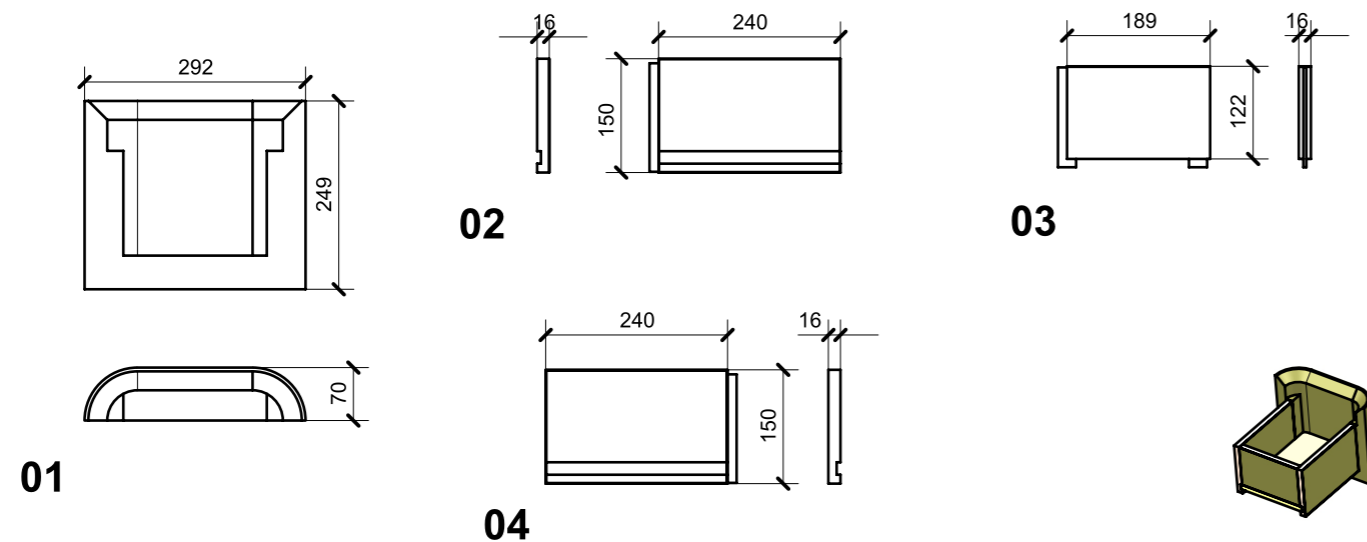
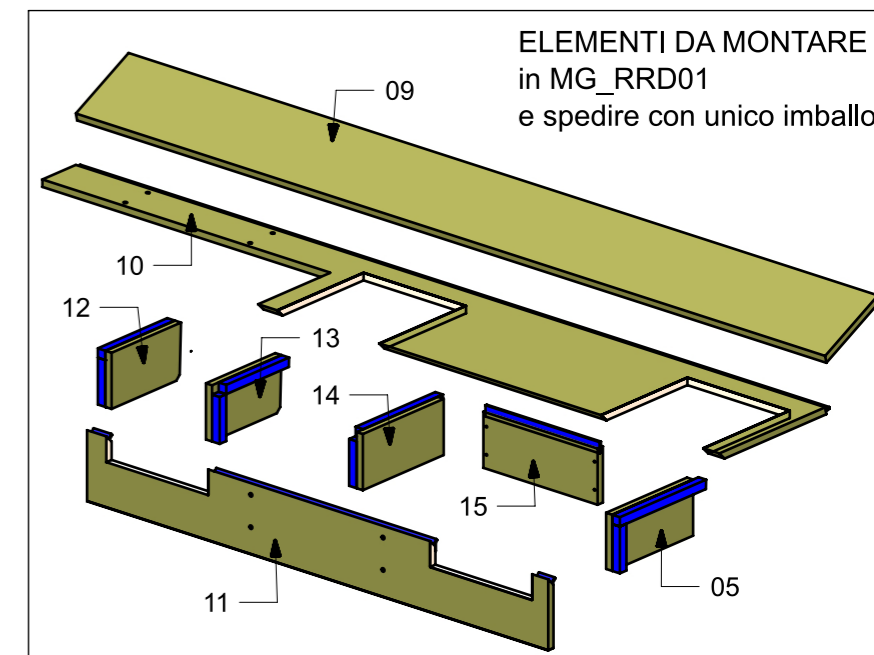
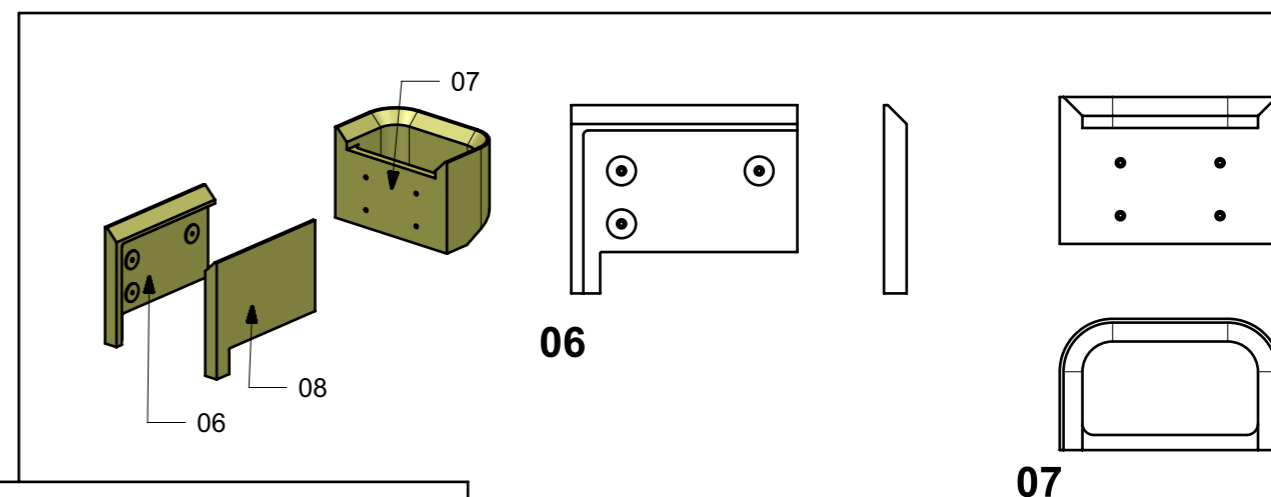
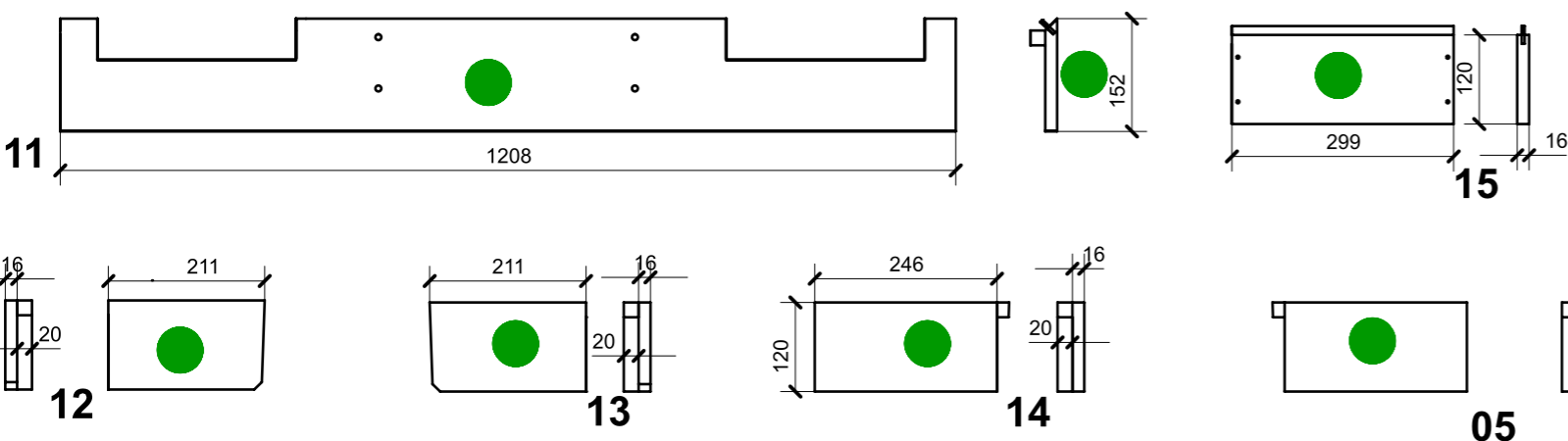
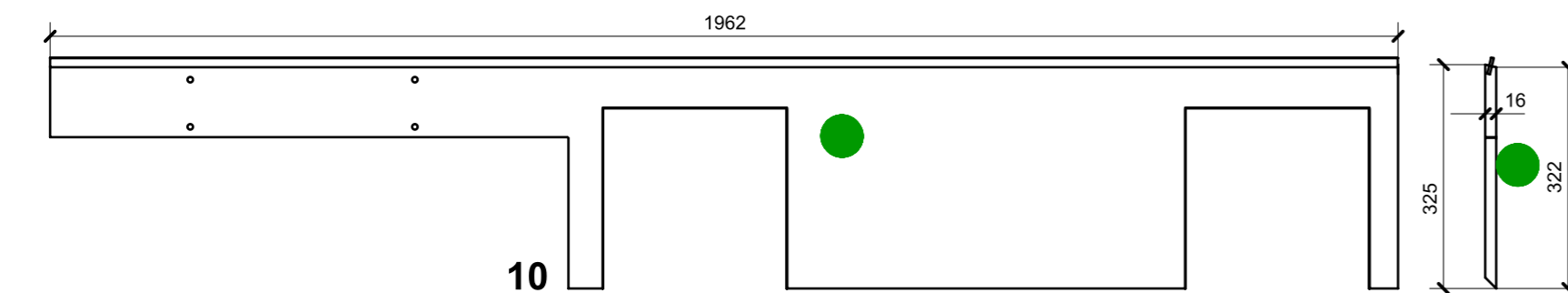
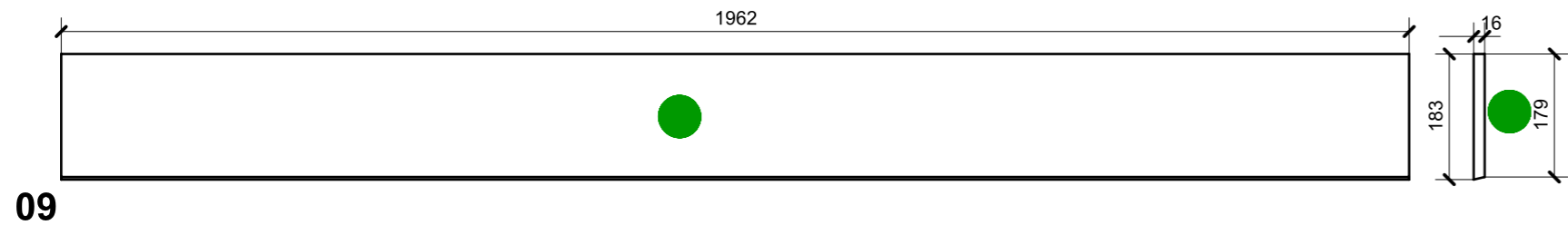

ELEMENTI DA MONTARE in MG_RRD01 e spedire con unico imballo

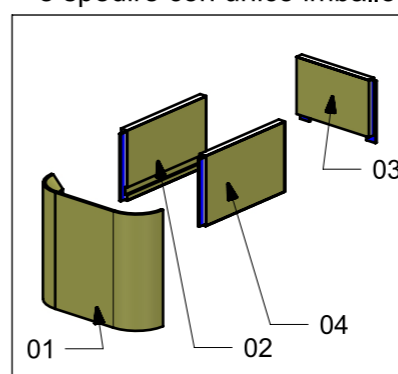

FERRAMENTA	QTY
BUSSOLA 6MA X 10 FORO DIAM.8	14

VERNICIATURA LASTRA/LACCATI:
 ● = VERNICIARE 1 LATO + FILI RASATI O BORDATI
 NESSUN SIMBOLO = VERNICIARE 2 LATI + FILI RASATI O BORDATI

LOCALE	CODICE	DESCRIZIONE COMPONENTE	FINITURA	GR.
CABINA OSPITI DX	MD320_L01_RE01	RIV. PARETE POPPA	LACCATO BRONZO SPAZZOLATO	2

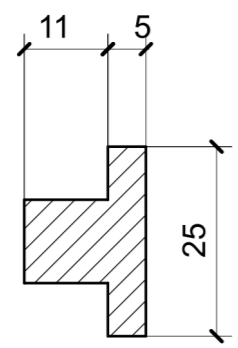
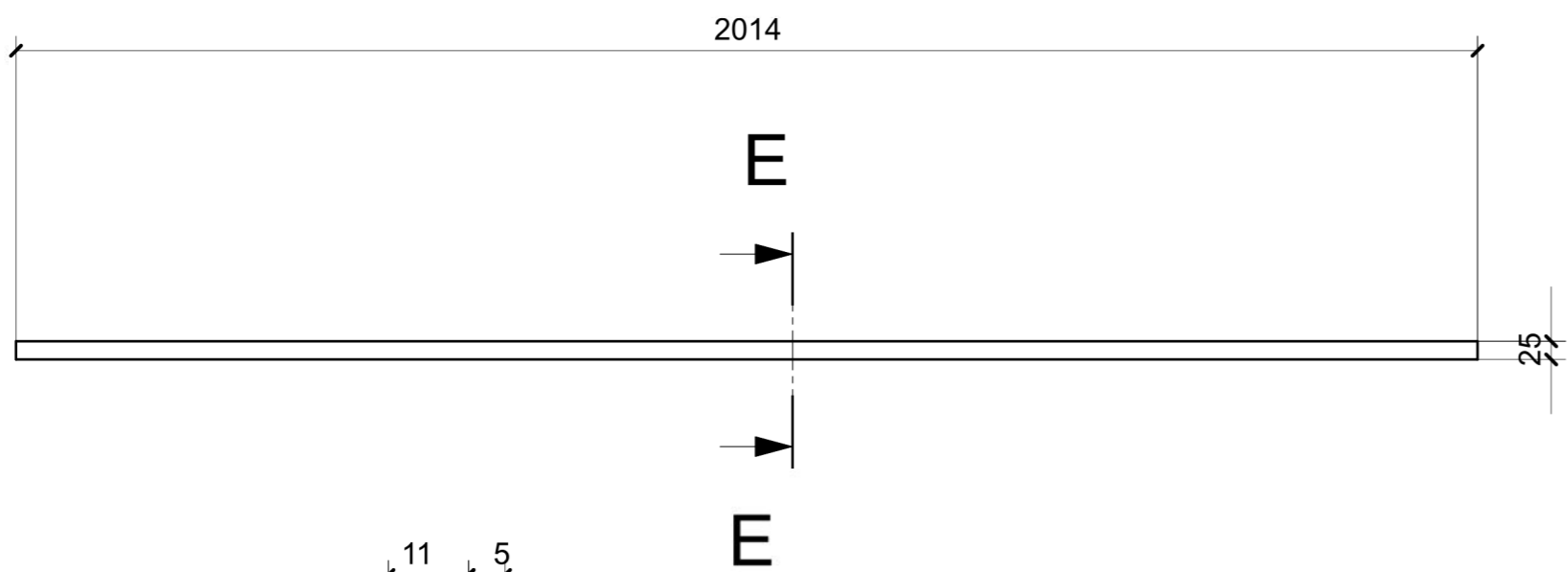

SECTION E-E
SCALE 1:1

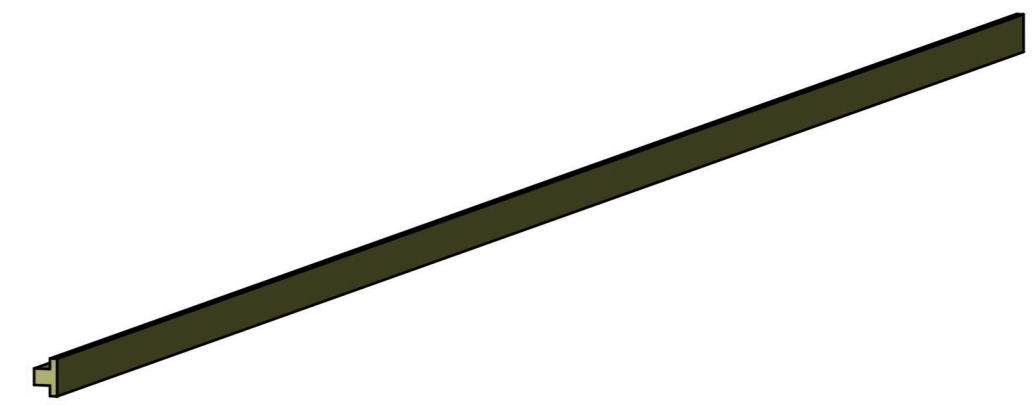

LOCALE	CODICE	DESCRIZIONE COMPONENTE	FINITURA	GR.
CABINA OSPITI DX	MD320_L01_RH01	CORNICE TV	LACCATO BRONZO	2

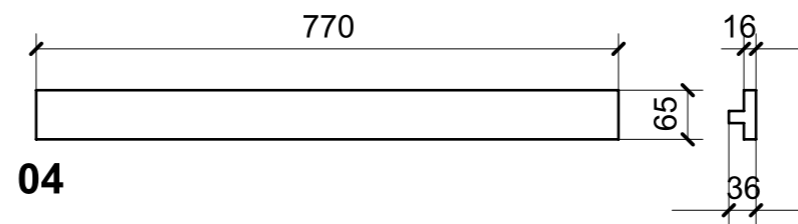
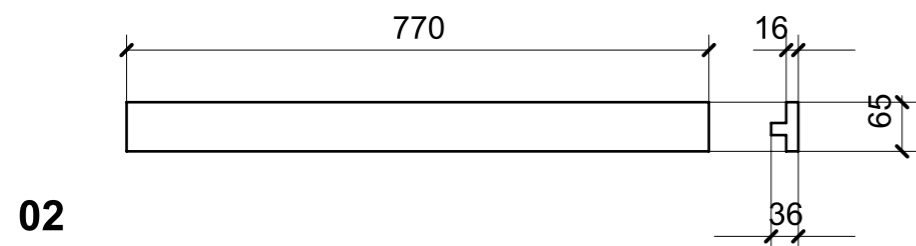
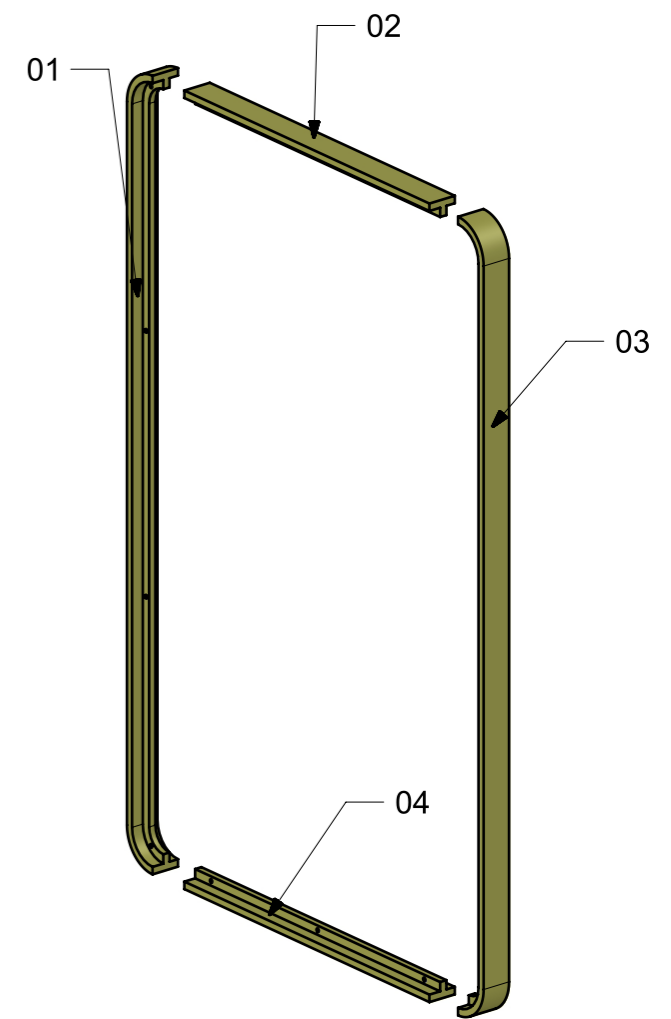
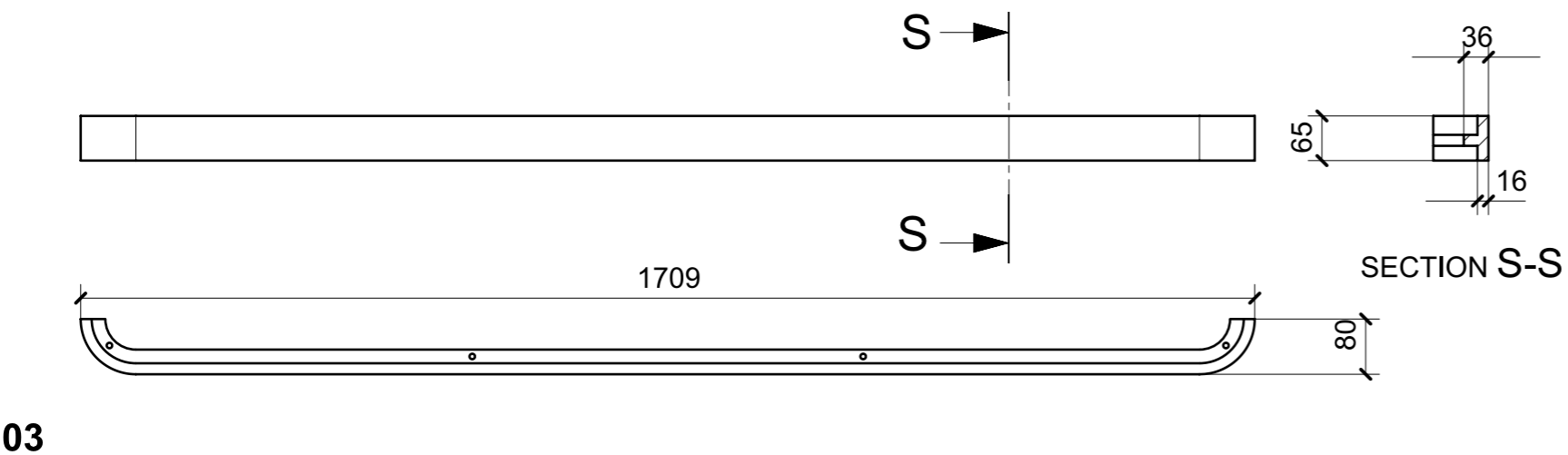
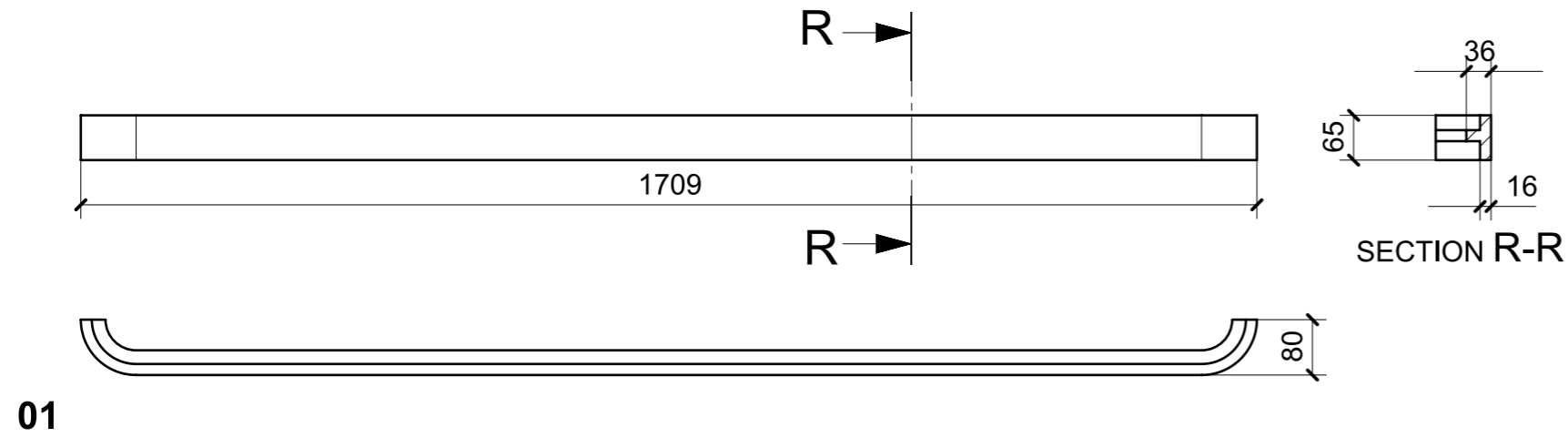

FERRAMENTA	QTY
BUSSOLA 6MA X 10 FORO DIAM.8	14
VITE 6MA X 25 TESTA BOMBATA	8

VERNICIATURA LASTRA/LACCATI:

● = VERNICIARE 1 LATO + FILI RASATI O BORDATI

NESSUN SIMBOLO = VERNICIARE 2 LATI + FILI RASATI O BORDATI

LOCALE	CODICE	DESCRIZIONE COMPONENTE	FINITURA	GR.
CABINA OSPITI DX	MD320_L02_RL01	CIELINO	LACCATO NCS- S - 1002-Y -MANOPESCA	3

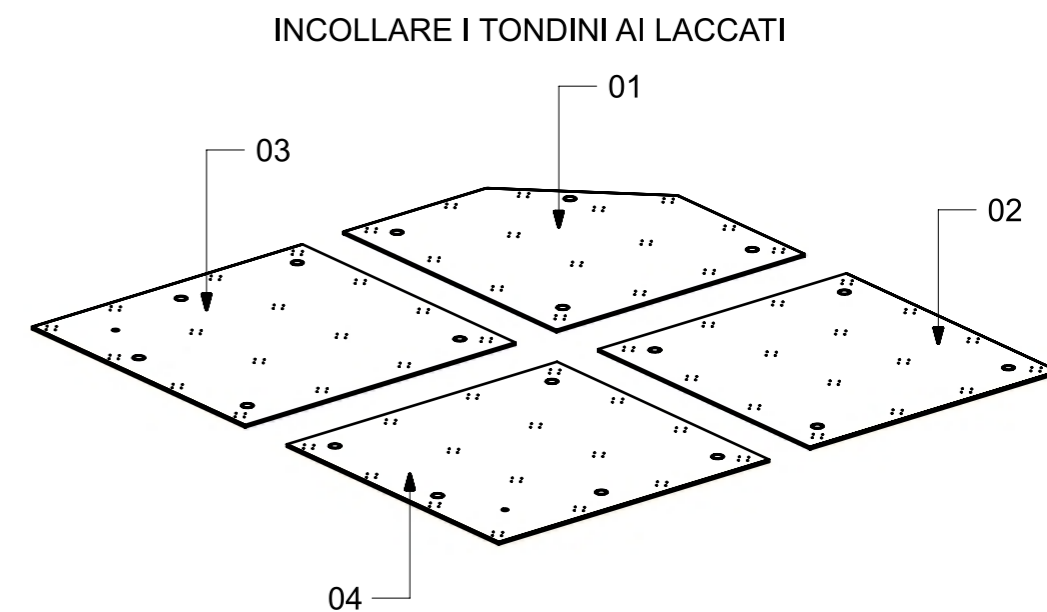
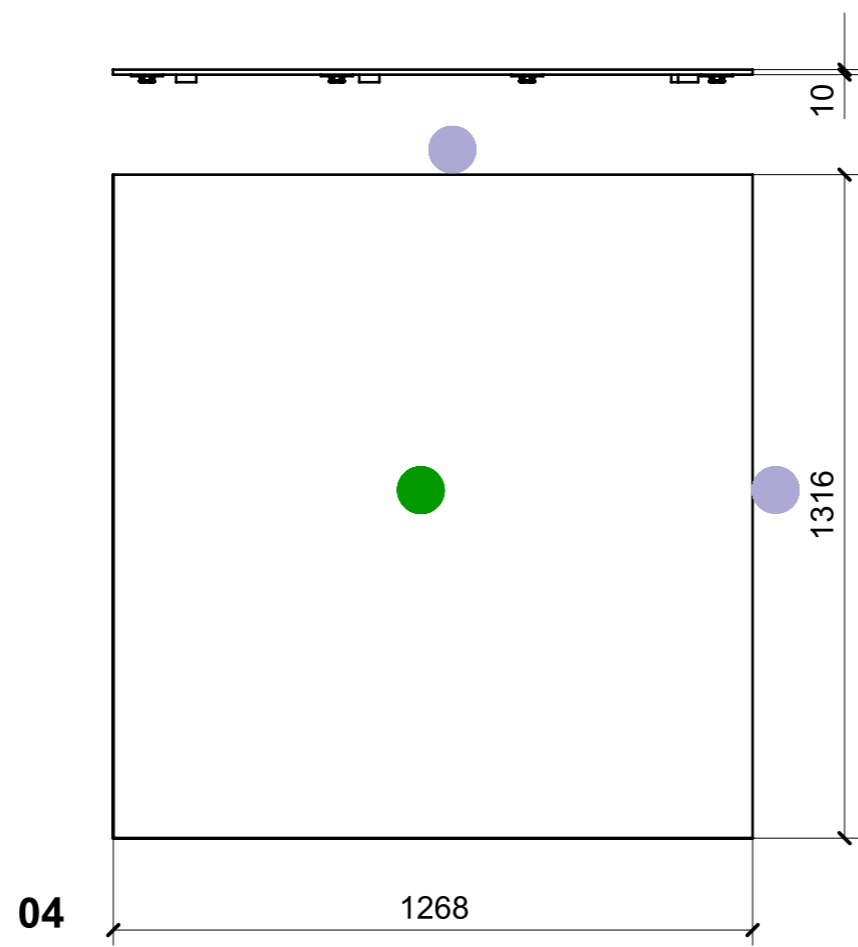
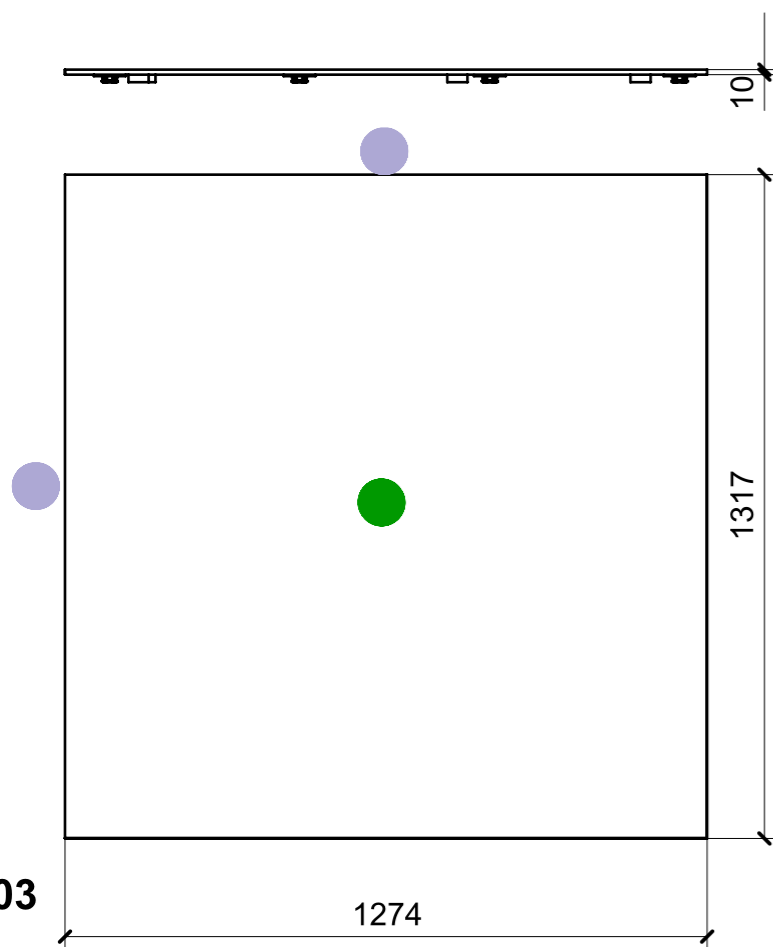
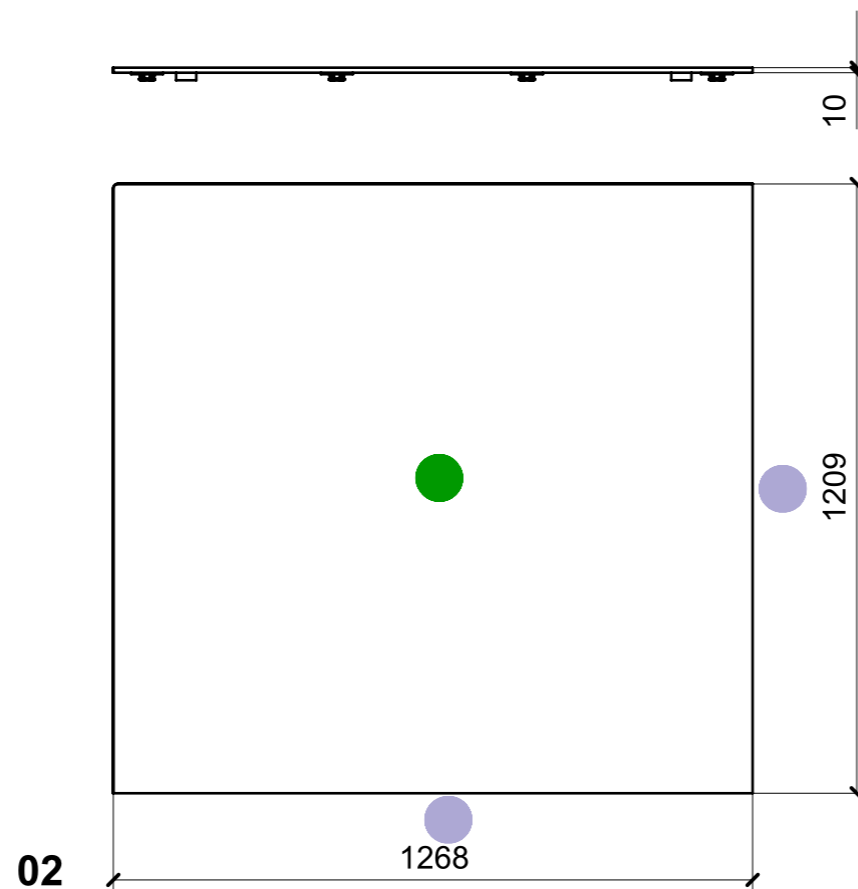
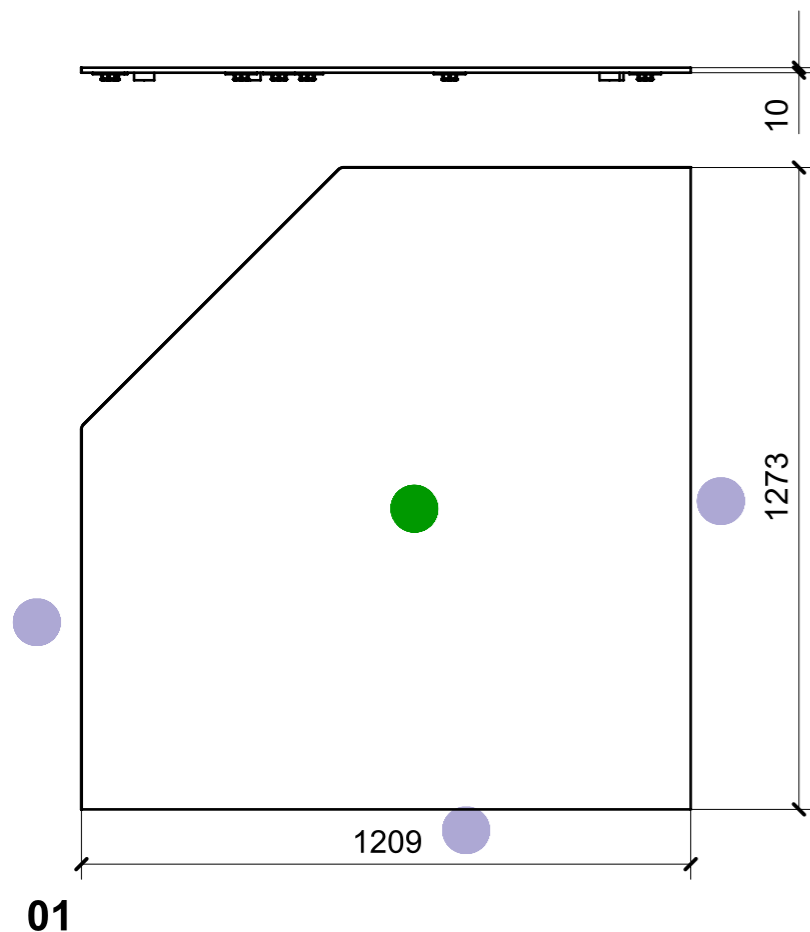

FERRAMENTA	QTY
TONDINO PER CENTRAGGIO ANTICADUTA 40X15	18
FITLOCK M_MASCHERPA_3MM_6020202101	63

● = FILI RASATI
(gli altri sono bordati)

VERNICIATURA LASTRA/LACCATI:
● = VERNICIARE 1 LATO + FILI RASATI O BORDATI
NESSUN SIMBOLO = VERNICIARE 2 LATI + FILI RASATI O BORDATI