

LOCALE	CODICE	DESCRIZIONE COMPONENTE	FINITURA	GR
CABINA VIP SX	MD320_L01_VVA01	STRUTTURA MURATA TESTATA LETTO	LACCATO BRONZO SPAZZOLATO	3

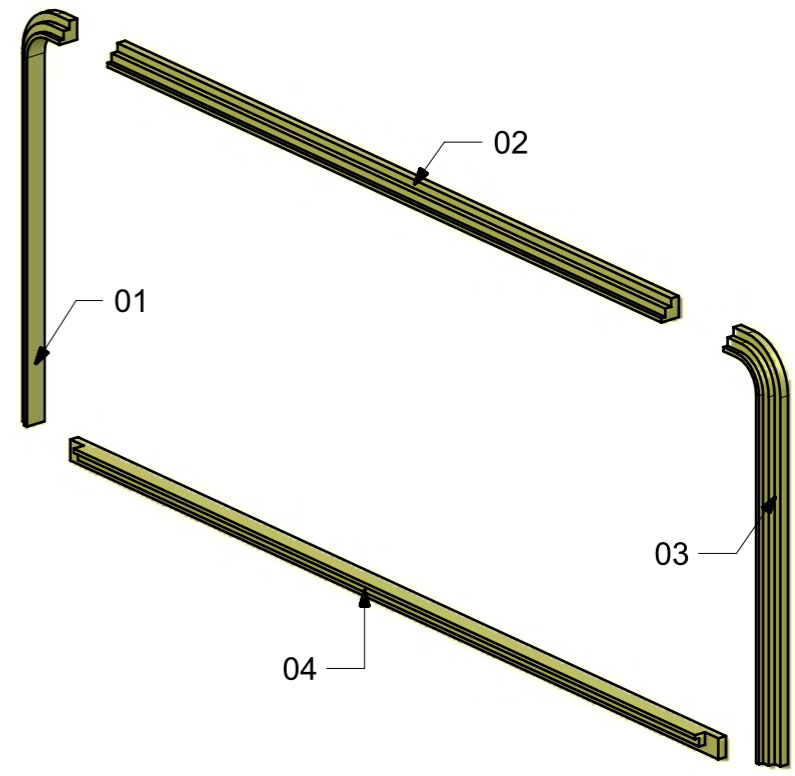

LOCALE	CODICE	DESCRIZIONE COMPONENTE	FINITURA	Q.TA
CABINA VIP SX	MD320_VVB01	COMODINO PRUA	LACCATO BRONZO SPAZZOLATO	2

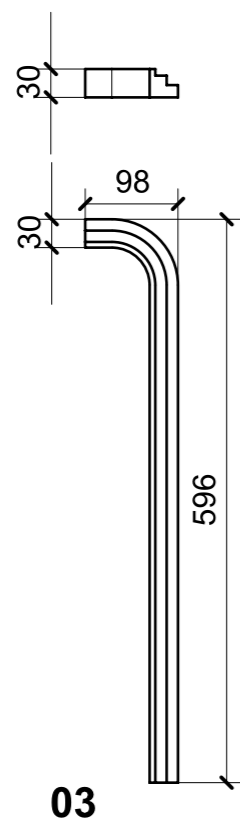
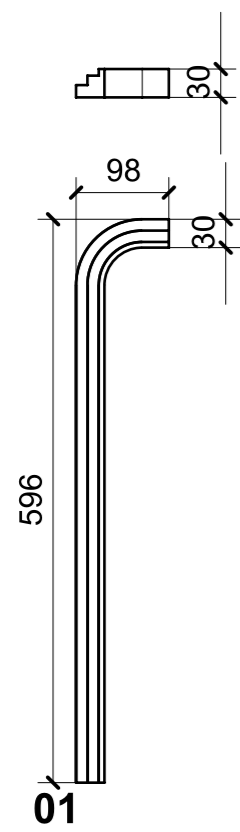
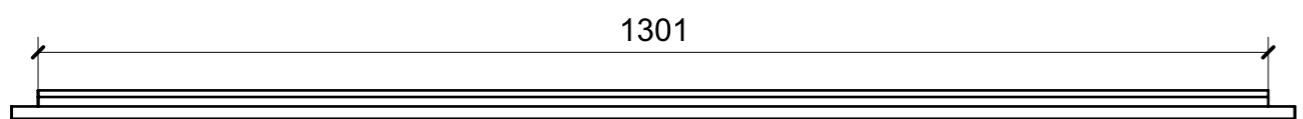
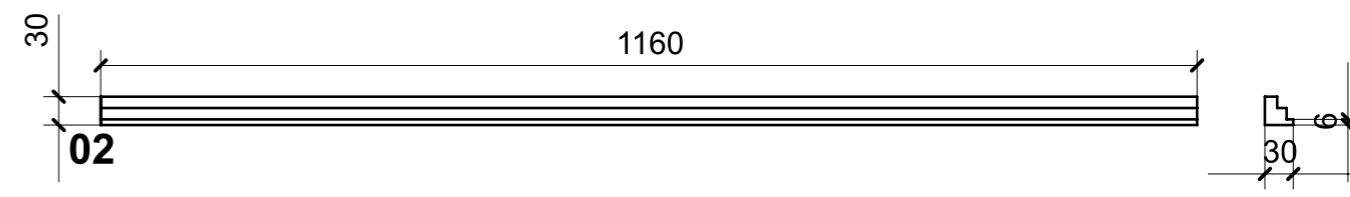
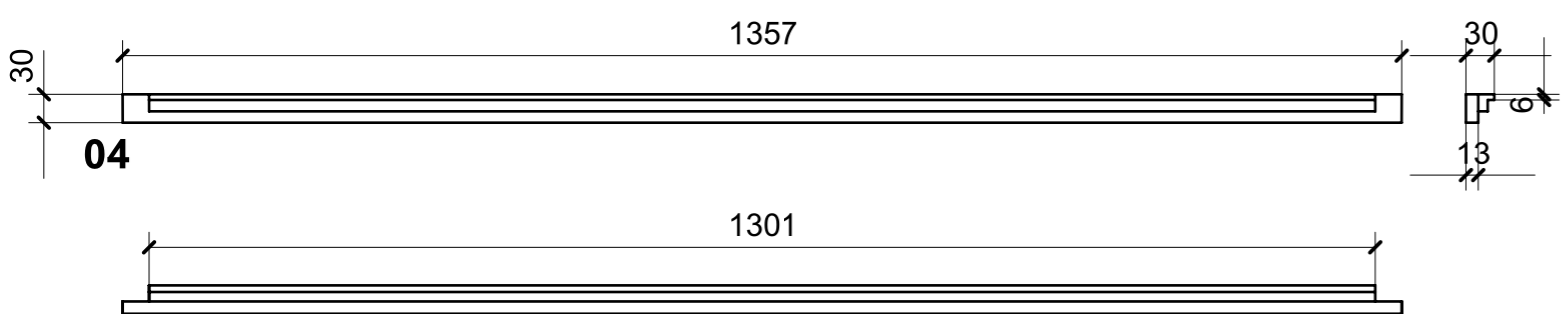
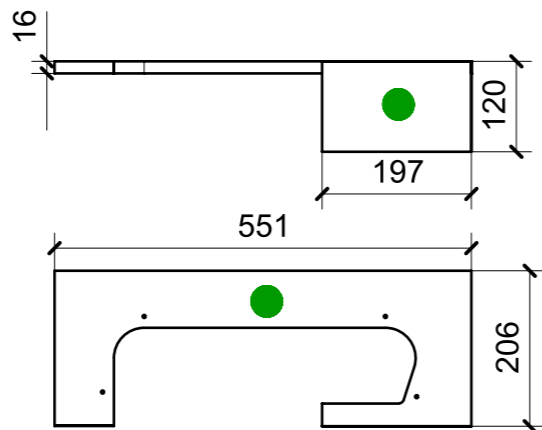
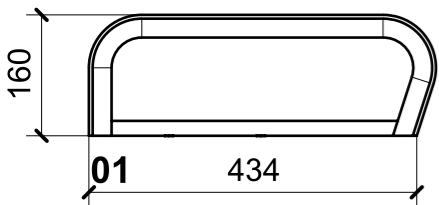
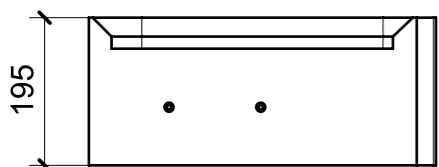

02

ELEMENTI DA MONTARE
in MG_VVB01
e spedire con unico imballo

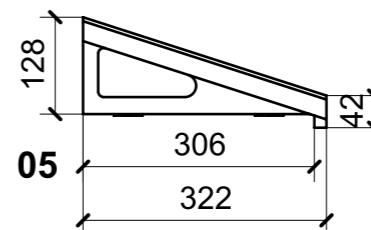
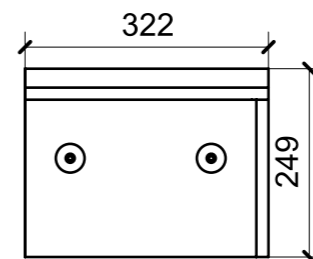
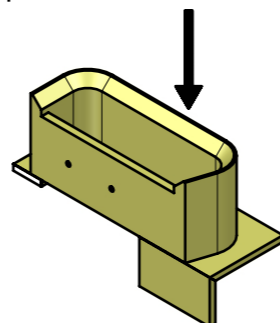

05

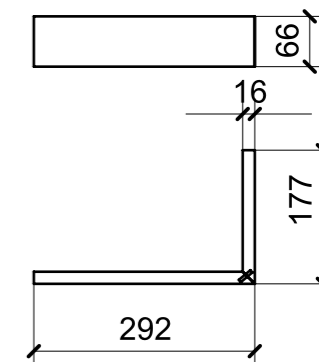

06

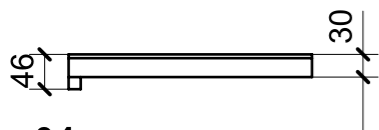
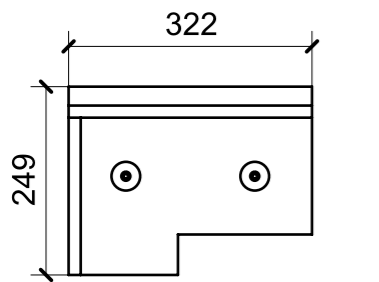

04

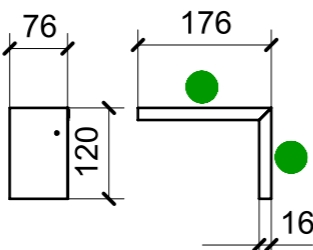

03

ELEMENTI DA MONTARE
in MG_VVB02
e spedire con unico imballo

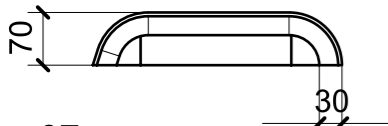
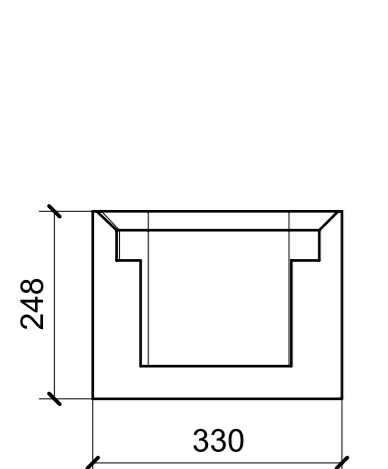
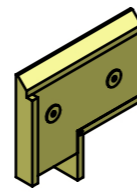

07

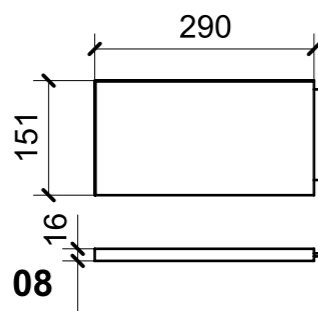

08

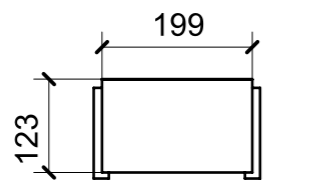

09

ELEMENTI DA MONTARE
con X01_VVB01_01
in MF_VVB01
e spedire con unico imballo

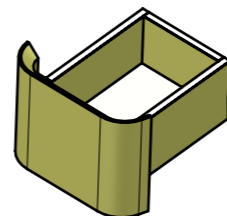

10

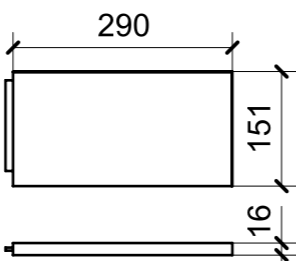

MG_VVB02

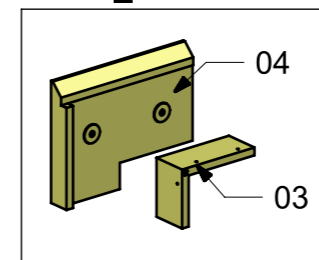

MG_VVB01

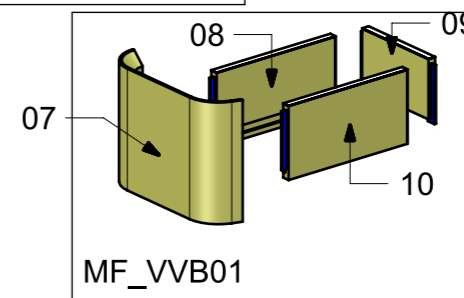
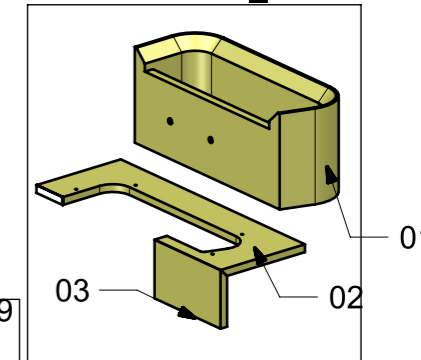

MF_VVB01

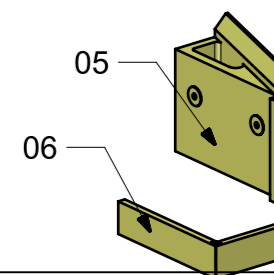

FERRAMENTA
BUSSOLA 6MA X 10 FORO DIAM.8

QTY
6

VERNICIATURA LASTRA/LACCATI:

● = FILI RASATI

● = VERNICIARE 1 LATO + FILI RASATI O BORDATI

NESSUN SIMBOLO = VERNICIARE 2 LATI + FILI RASATI O BORDATI

LOCALE	CODICE	DESCRIZIONE COMPONENTE	FINITURA	Q.TA
CABINA VIP SX	MD320_L01_VVC01	STRUTTURA LETTO	LACCATO BRONZO SPAZZOLATO	PTP

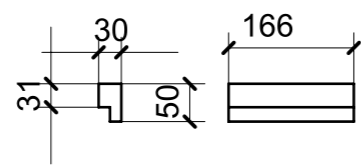
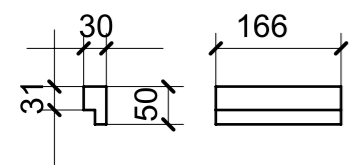
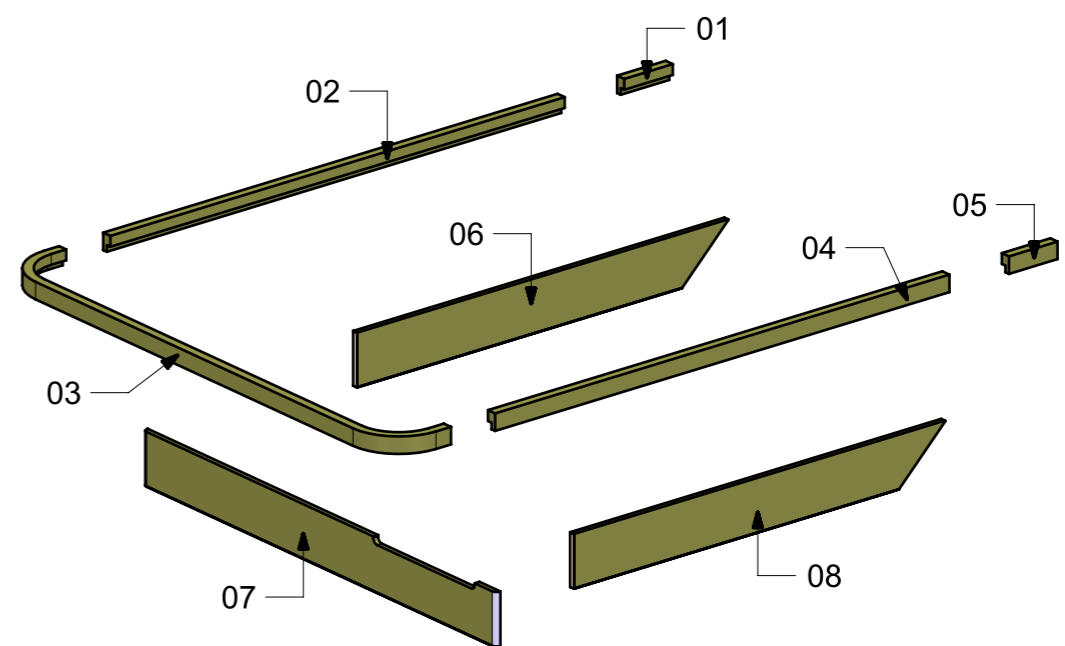
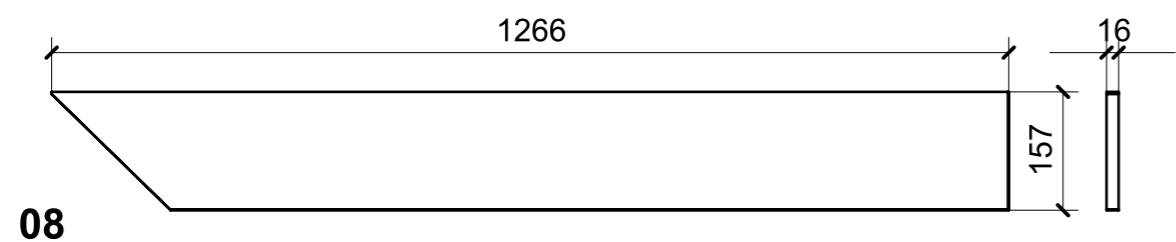
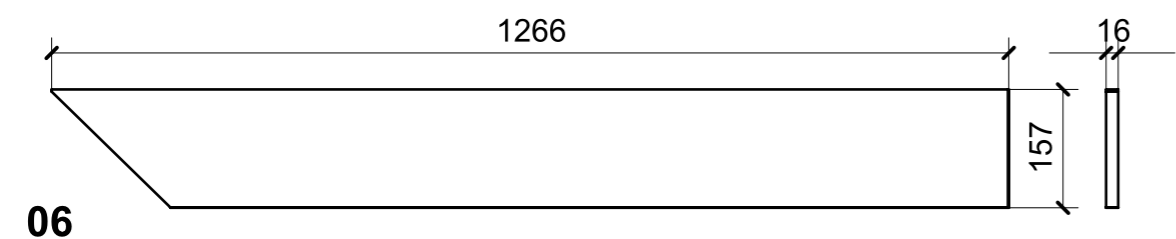
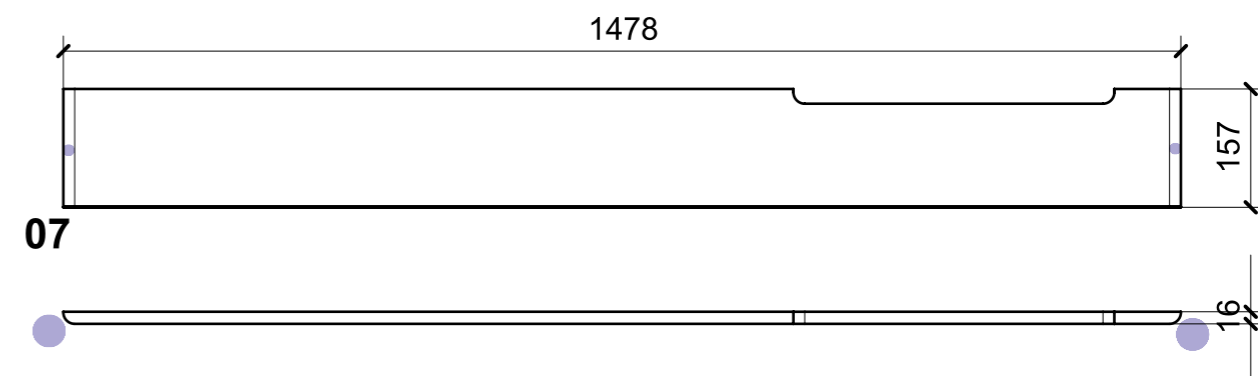
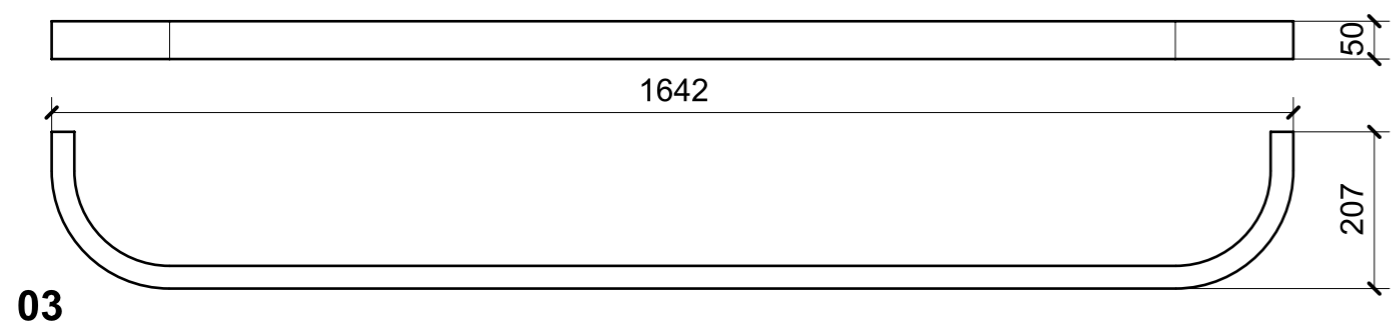
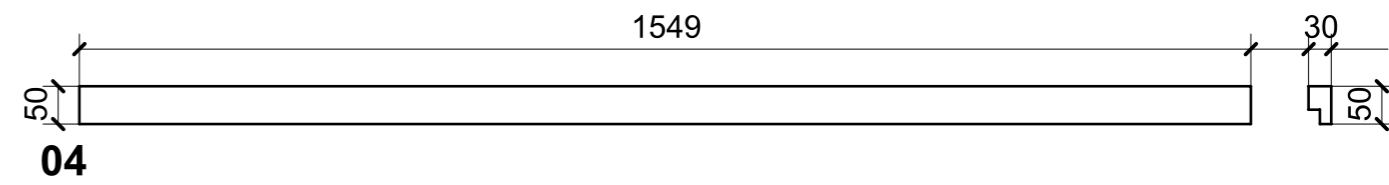
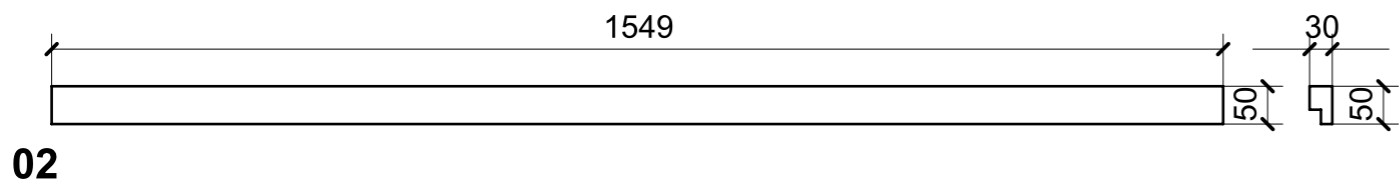

01

05

VERNICIATURA LASTRA/LACCATI:

● = FILI RASATI

● = VERNICIARE 1 LATO + FILI RASATI O BORDATI

NESSUN SIMBOLO = VERNICIARE 2 LATI + FILI RASATI O BORDATI

LOCALE	CODICE	DESCRIZIONE COMPONENTE	FINITURA	Q.TA
CABINA VIP SX	MD320_L01_VVD01	COMODINO POPPA	LACCATO BRONZO SPAZZOLATO	2

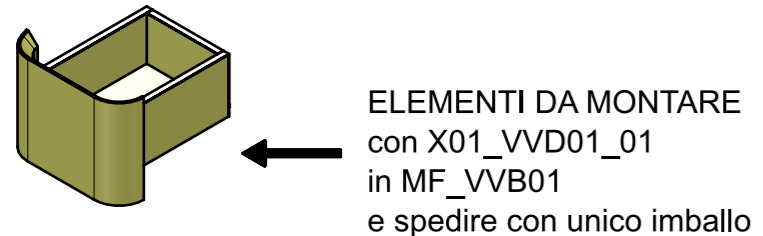
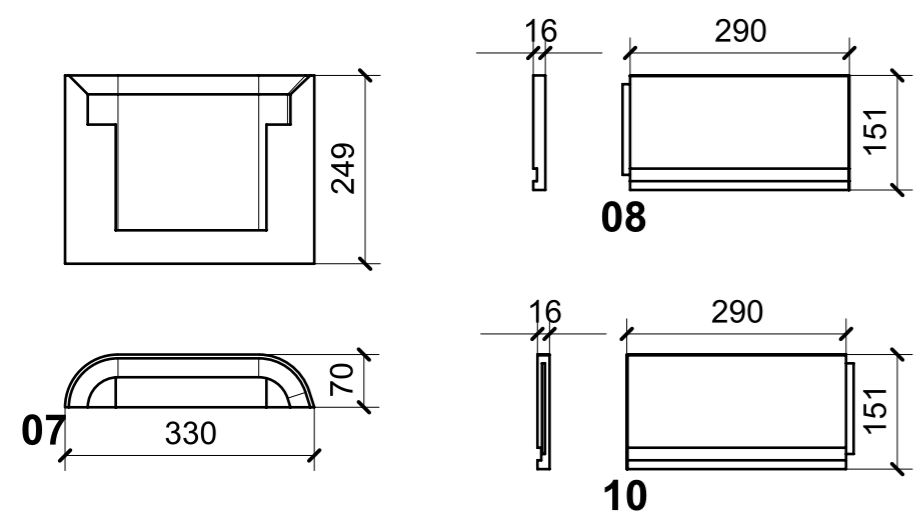
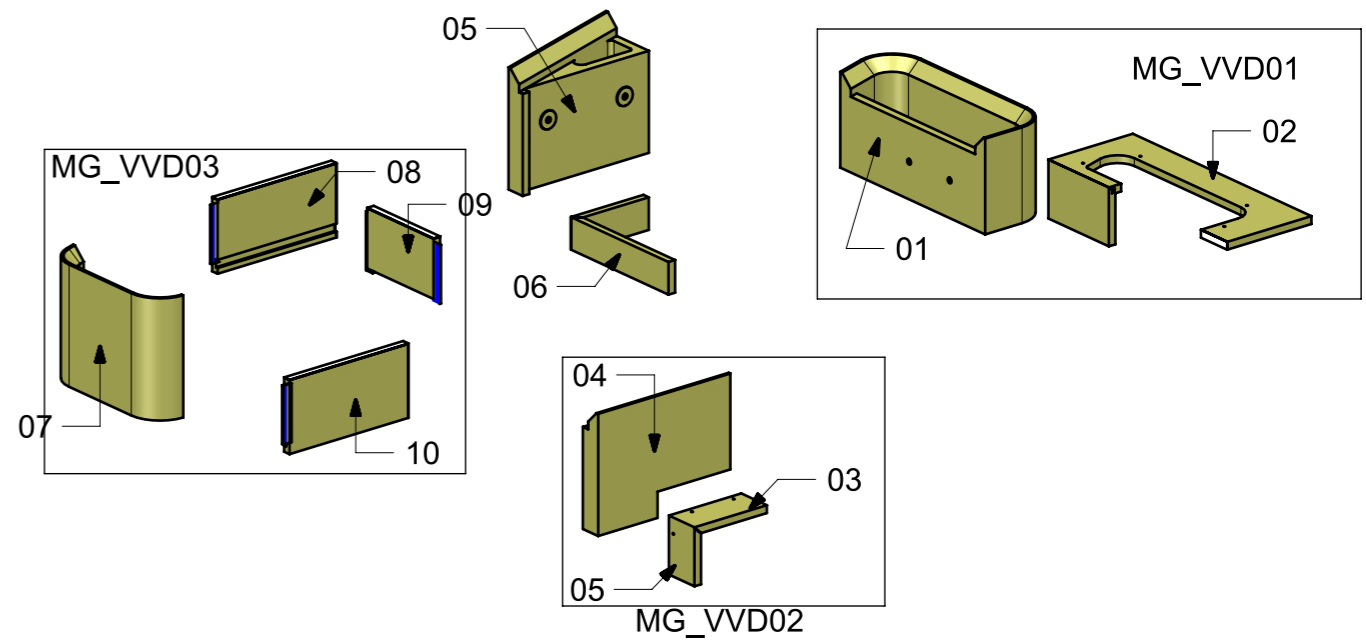
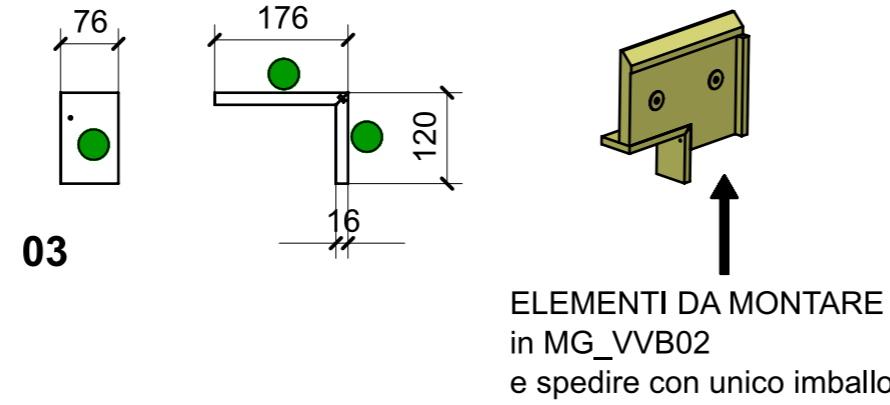
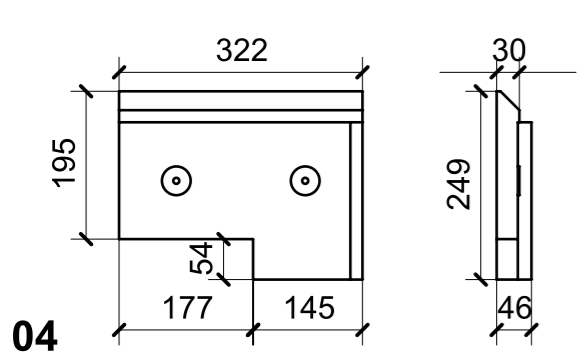
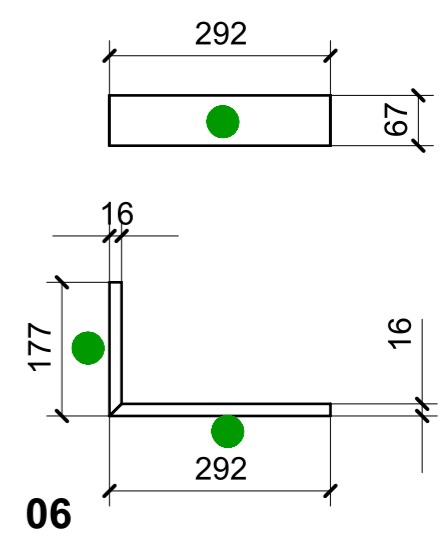
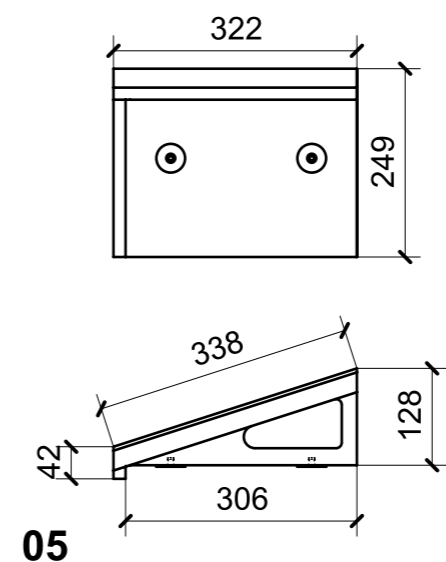
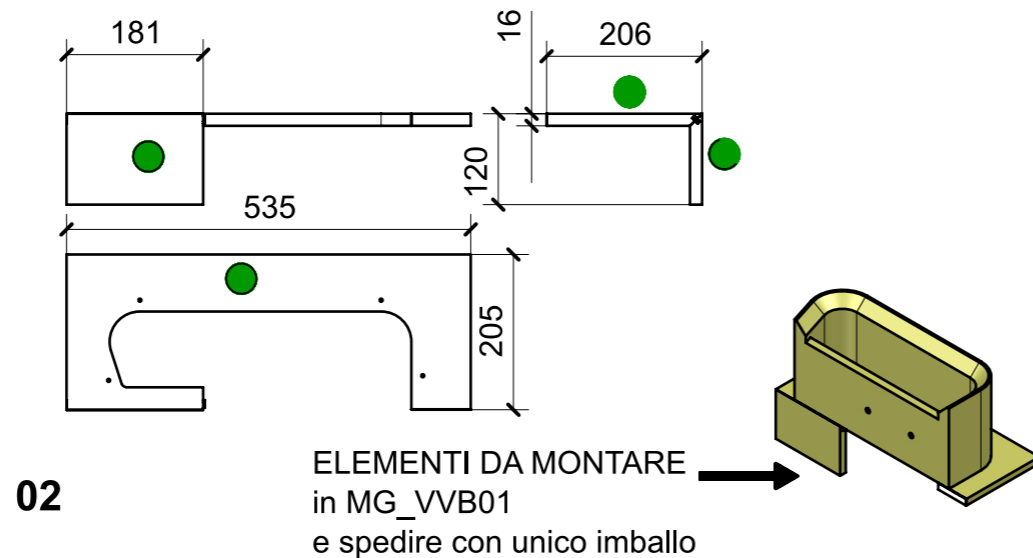
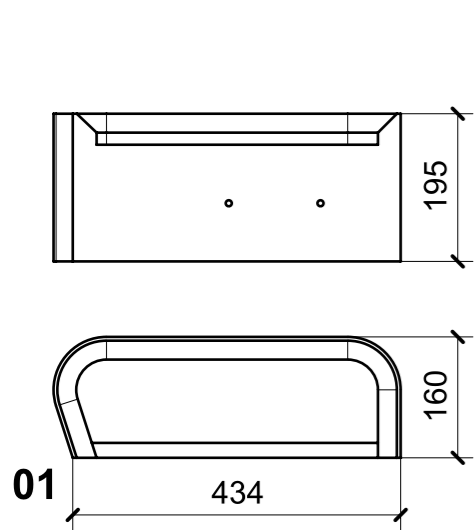

FERRAMENTA	QTY
GUIDA DYNAPRO ADJUSTAMENT ADAPTER L_FBC_F134141746 4D	1
GUIDA DYNAPRO FRONT LOCKING DEVICE L_FBC_F134108955 4D	1
GUIDA DYNAPRO ADJUSTAMENT ADAPTER R_FBC_F134141746 4D	1
GUIDA DYNAPRO FRONT LOCKING DEVICE R_FBC_F134108955 4D	1
BUSSOLA 6MA X 10 FORO DIAM.8	6

VERNICIATURA LASTRA/LACCATI: ● = FILI RASATI ● = VERNICIARE 1 LATO + FILI RASATI O BORDATI NESSUN SIMBOLO = VERNICIARE 2 LATI + FILI RASATI O BORDATI

LOCALE	CODICE	DESCRIZIONE COMPONENTE	FINITURA	Q.TA
CABINA VIP SX	MD320_L01_VVE01	RIVESTIMENTI PARETI PRUA	LACCATO BRONZO SPAZZOLATO	3

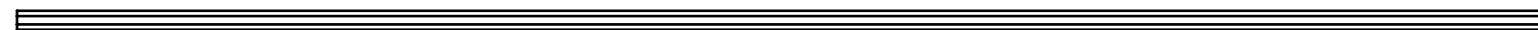

Ⓛ D

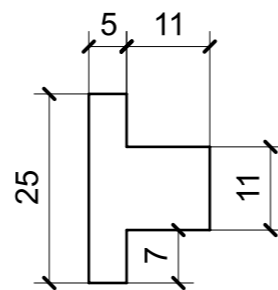

DETAIL D



VERNICIATURA LASTRA/LACCATI:

● = FILI RASATI

● = VERNICIARE 1 LATO + FILI RASATI O BORDATI

NESSUN SIMBOLO = VERNICIARE 2 LATI + FILI RASATI O BORDATI

LOCALE	CODICE	DESCRIZIONE COMPONENTE	FINITURA	GR
CABINA VIP SX	MD320_L01_VVF01	RIVESTIMENTI PARETI POPPA	LACCATO BRONZO SPAZZOLATO	3

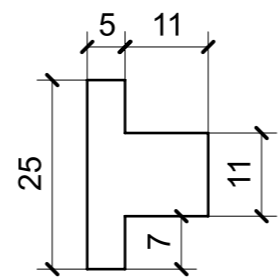
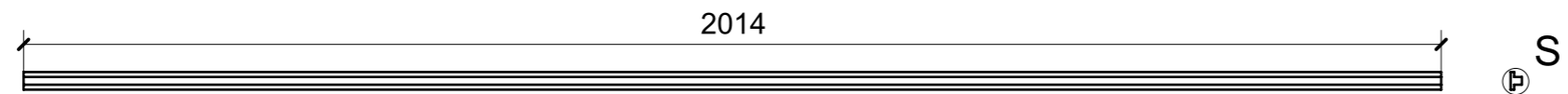

DETAIL S



VERNICIATURA LASTRA/LACCATI: ● = FILI RASATI

● = VERNICIARE 1 LATO + FILI RASATI O BORDATI

NESSUN SIMBOLO = VERNICIARE 2 LATI + FILI RASATI O BORDATI

LOCALE	CODICE	DESCRIZIONE COMPONENTE	FINITURA	GR
CABINA VIP SX	MD320_L01_VVG01	RIVESTIMENTI PARETI CENTRO NAVE	LACCATO BRONZO SPAZZOLATO	3

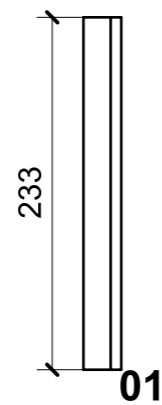

G

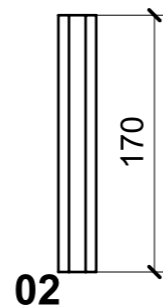

H

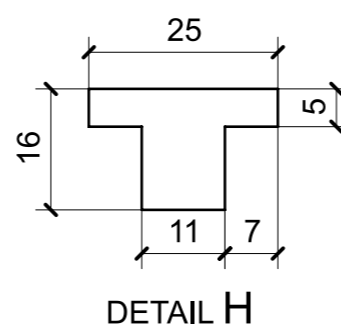
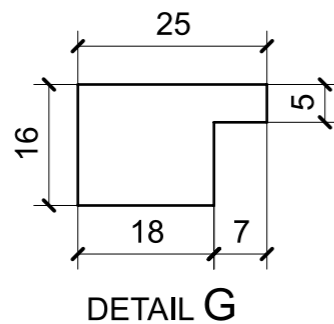
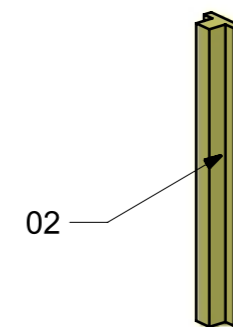
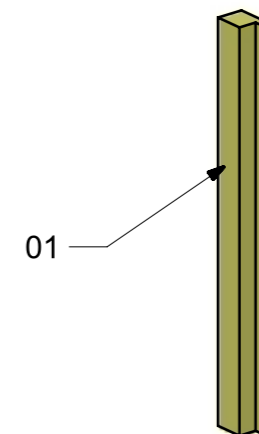

VERNICIATURA LASTRA/LACCATI:

● = FILI RASATI

● = VERNICIARE 1 LATO + FILI RASATI O BORDATI

NESSUN SIMBOLO = VERNICIARE 2 LATI + FILI RASATI O BORDATI

LOCALE	CODICE	DESCRIZIONE COMPONENTE	FINITURA	GR.
CABINA VIP SX	MD320_L01_VVH01	CORNICE TV	LACCATO BRONZO	2

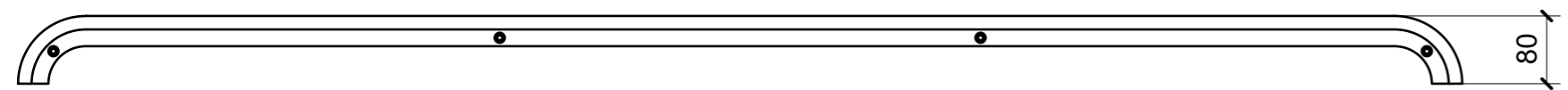
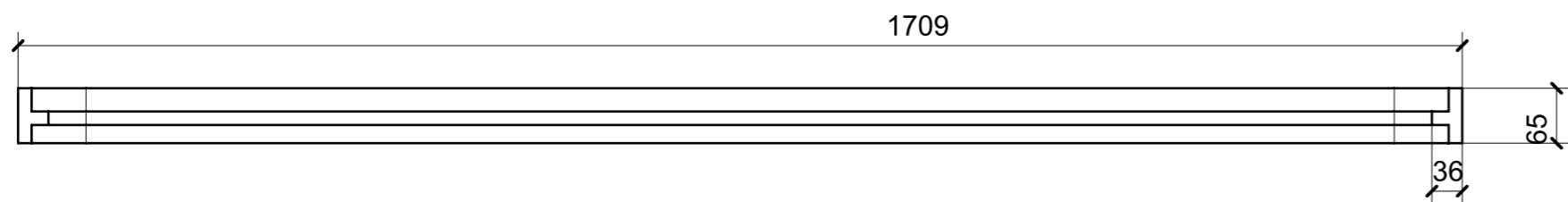

01

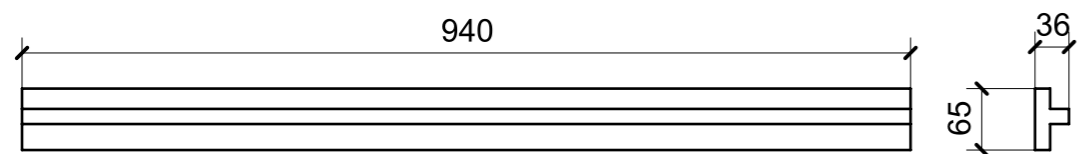

02

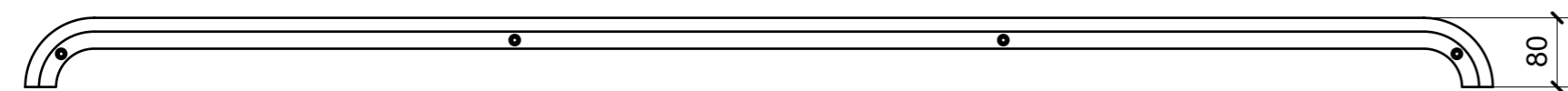
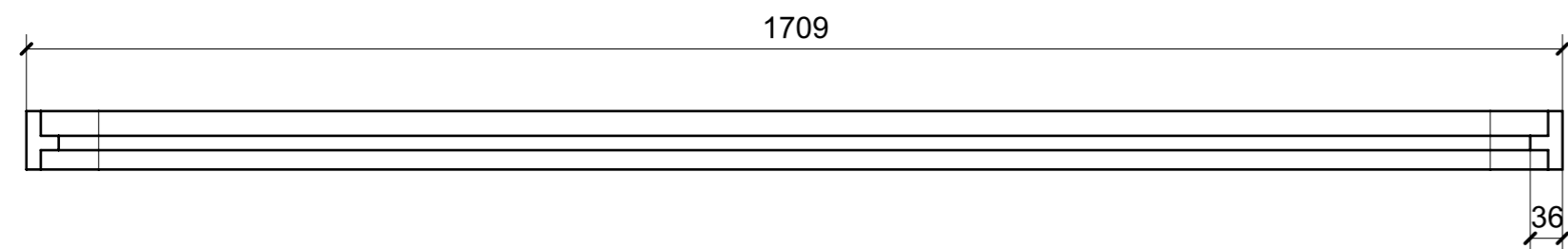

03

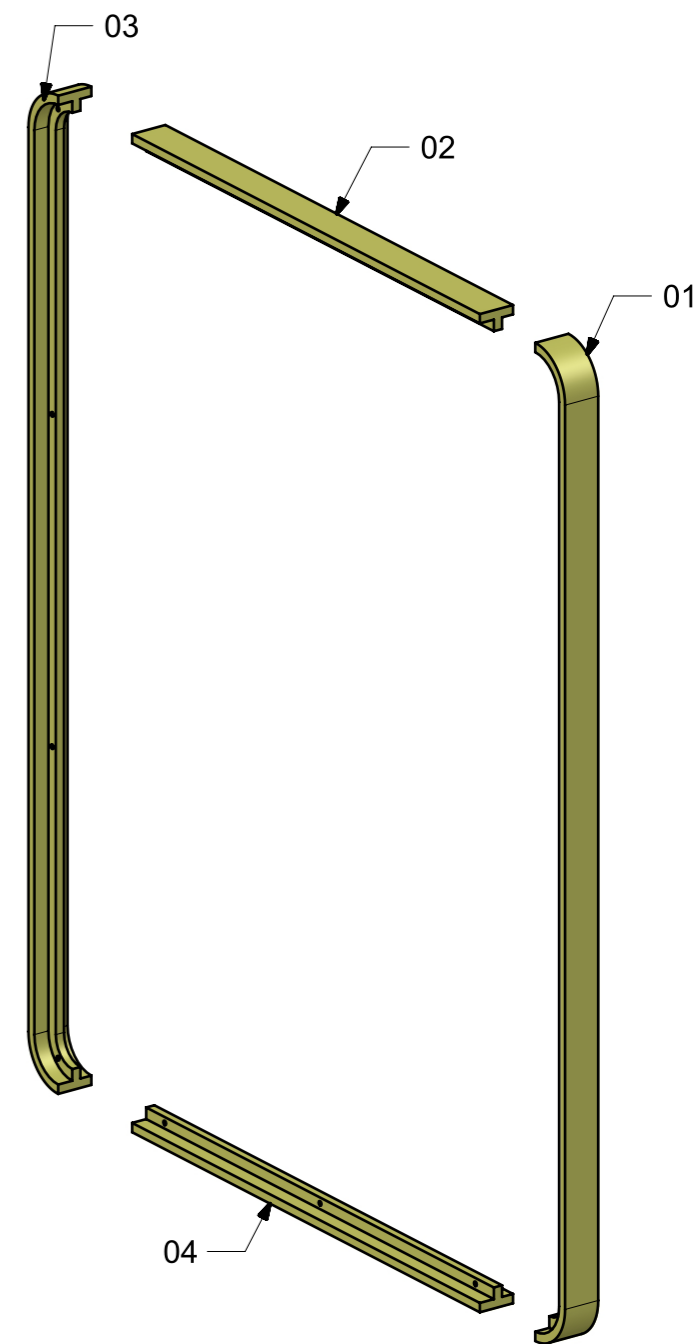
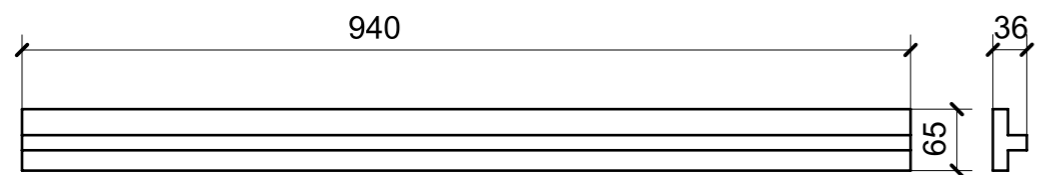

FERRAMENTA	QTY
BUSSOLA 6MA X 10 FORO DIAM.8	14

VERNICIATURA LASTRA/LACCATI:

● = FILI RASATI

● = VERNICIARE 1 LATO + FILI RASATI O BORDATI

NESSUN SIMBOLO = VERNICIARE 2 LATI + FILI RASATI O BORDATI

LOCALE	CODICE	DESCRIZIONE COMPONENTE	FINITURA	GR
CABINA VIP SX	MD320_L02_VVO01	CIELINO	LACCATO NCS- S - 1002-Y -MANOPESCA	3

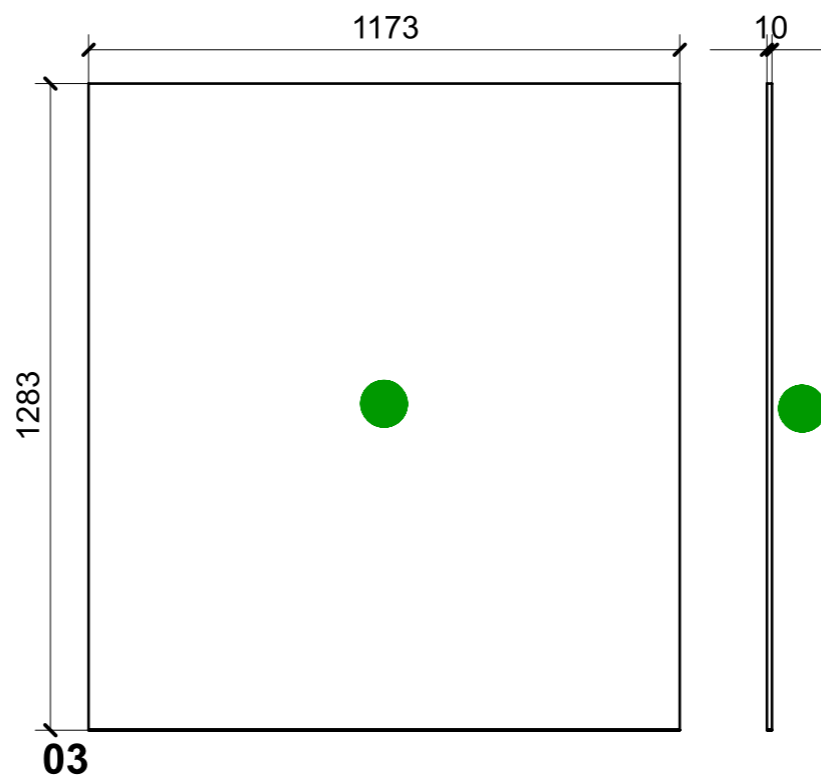
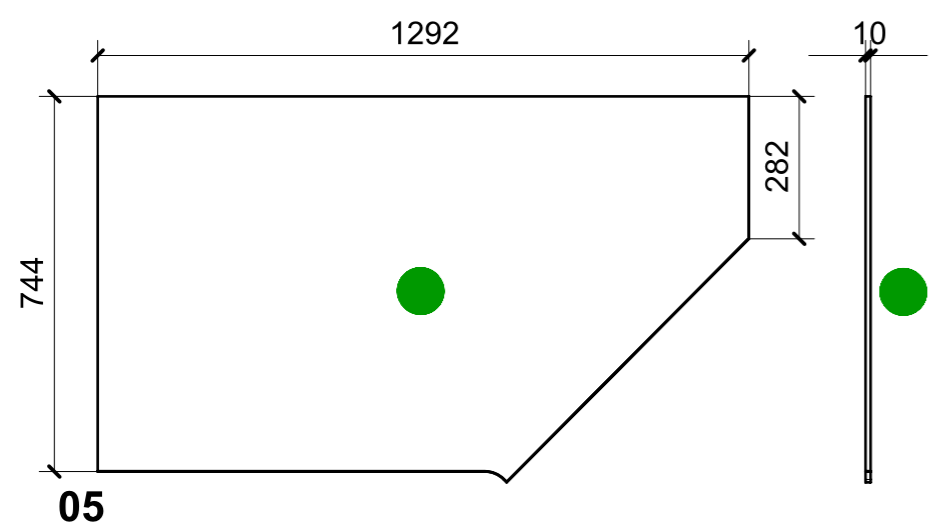
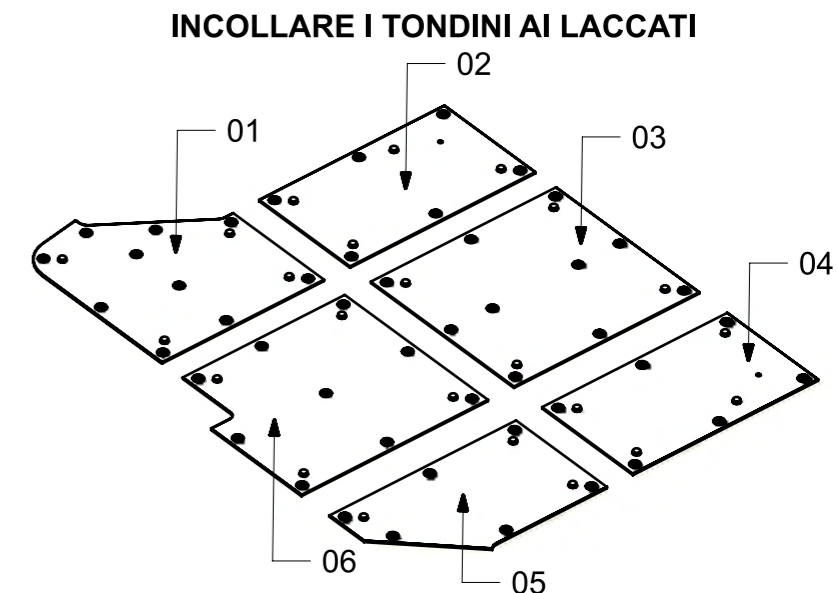
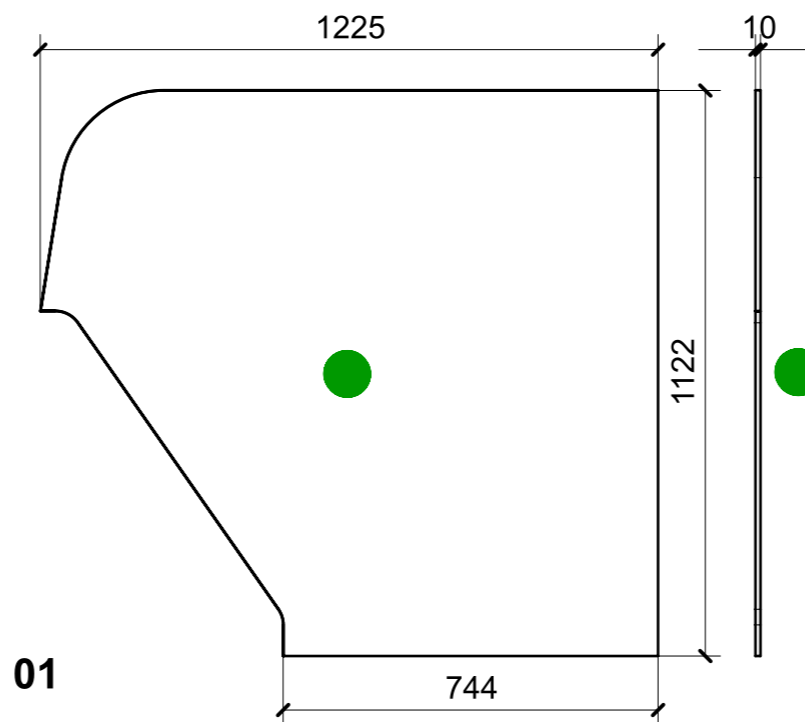
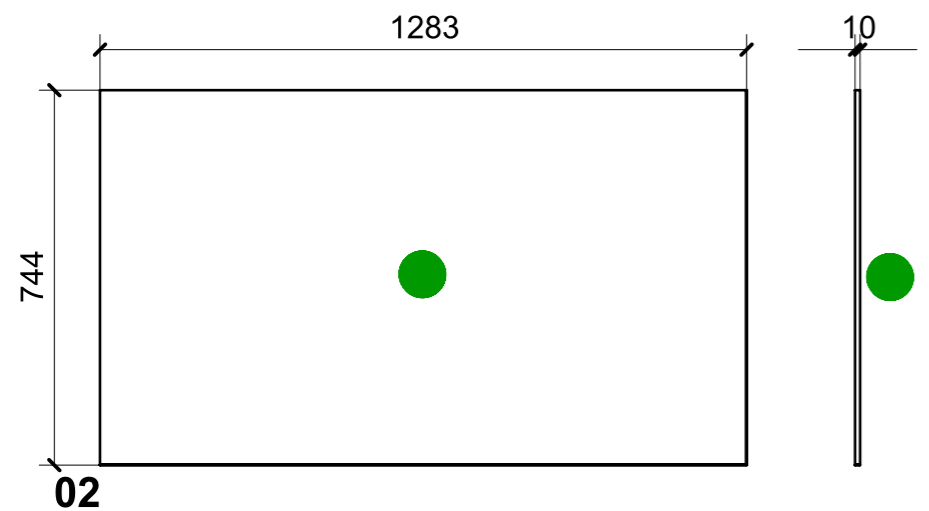

FERRAMENTA	QTY
TONDINO PER CENTRAGGIO ANTICADUTA 40X15	23
FITLOCK M_MASCHERPA_3MM_6020202101	47

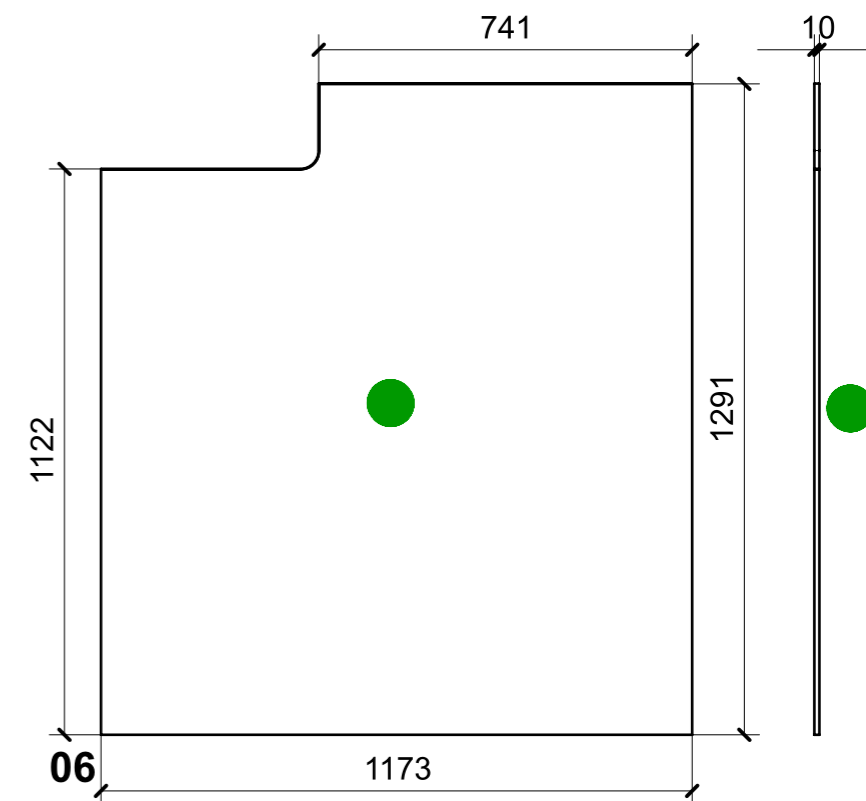
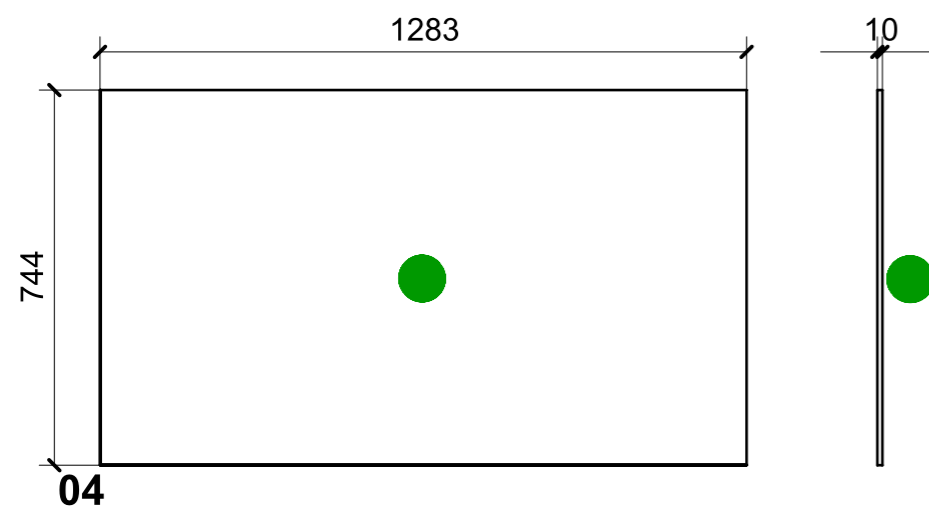

VERNICIATURA LASTRA/LACCATI: ● = VERNICIARE 1 LATO + FILI RASATI O BORDATI

NESSUN SIMBOLO = VERNICIARE 2 LATI + FILI RASATI O BORDATI