

LOCALE	CODICE	DESCRIZIONE COMPONENTE	FINITURA	GR.
CABINA ARMATORE	MD320_R01_AA01	ARMADIO INGRESSO DX POPPA	LASTRA SCURA	2

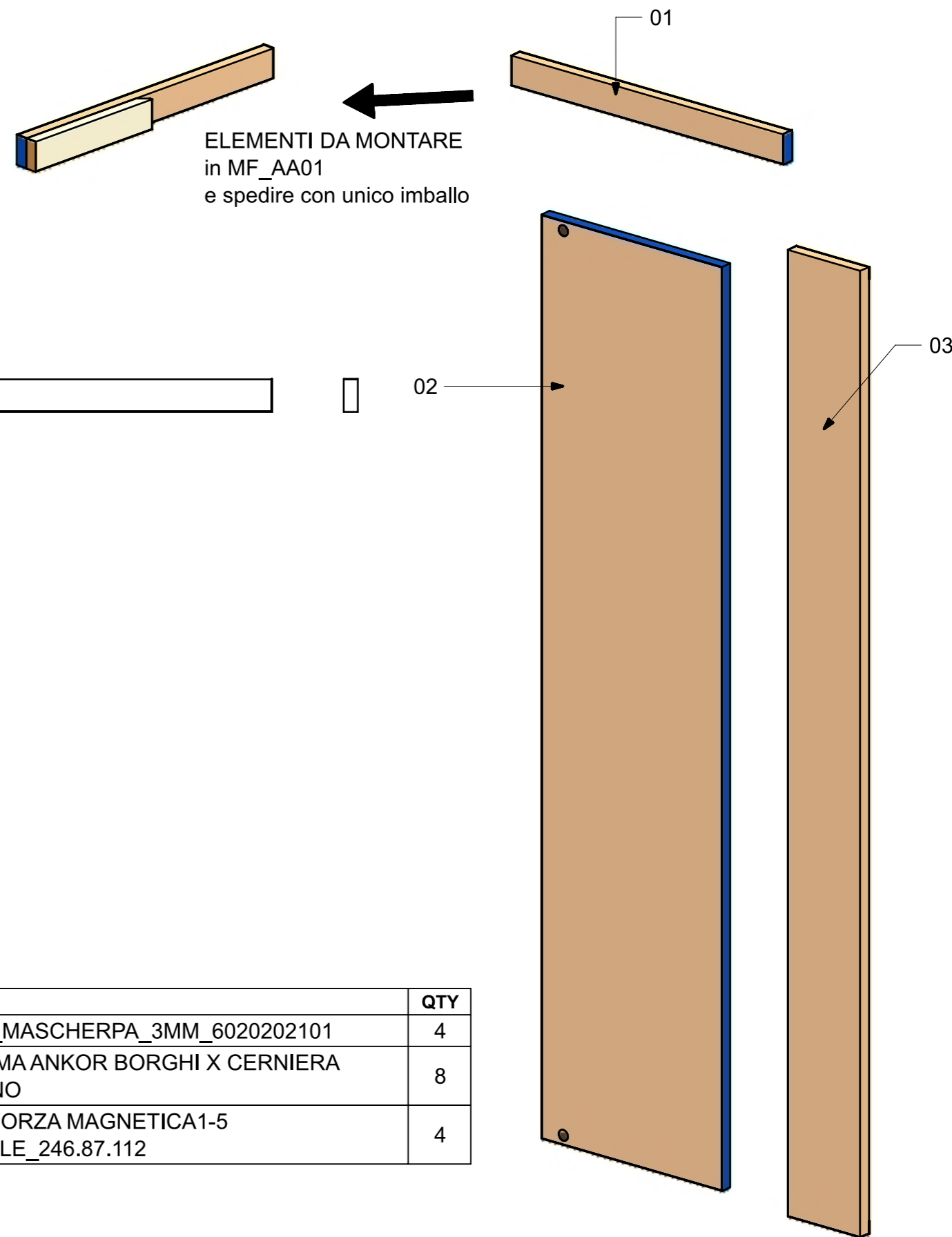
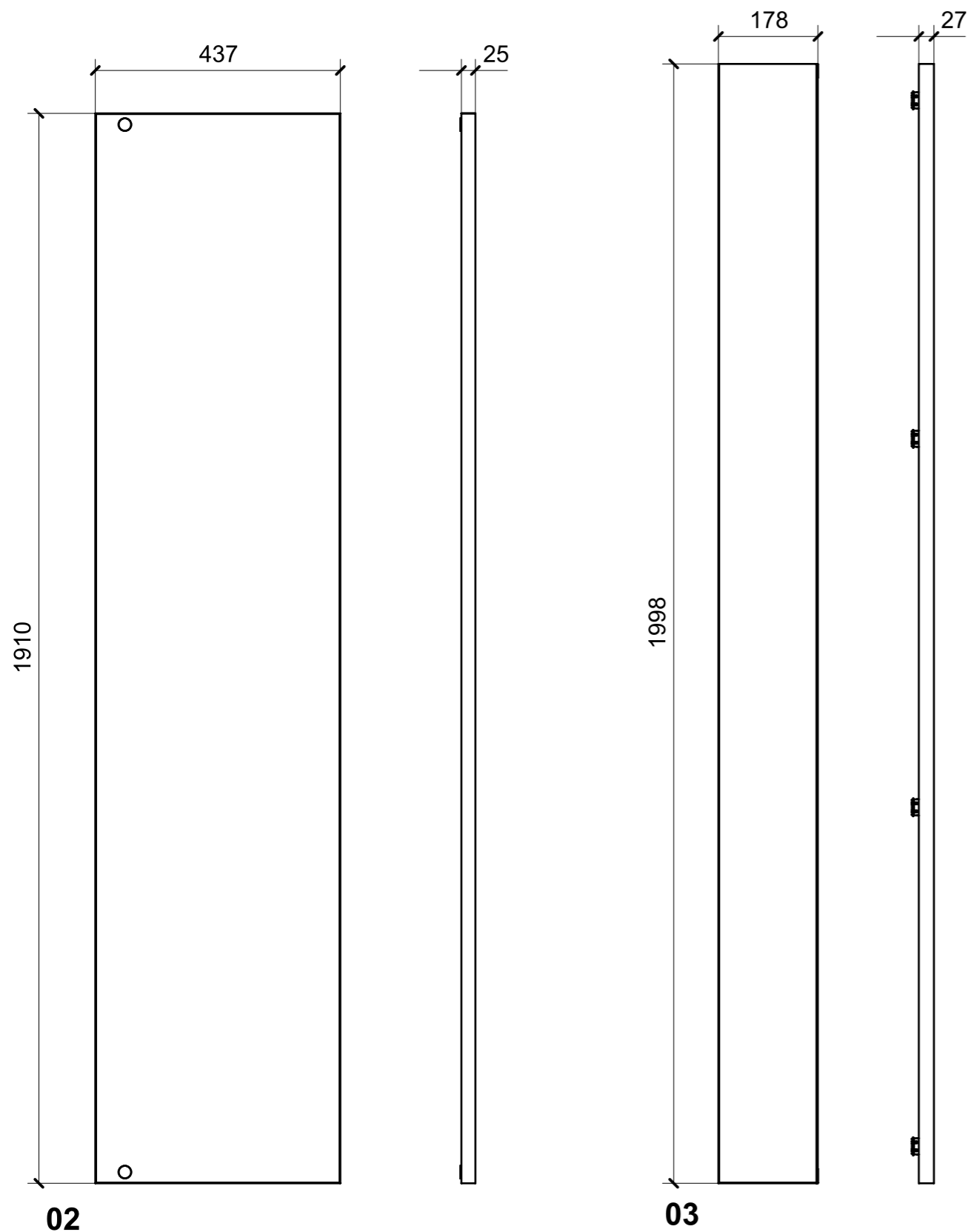

FERRAMENTA	QTY
FITLOCK M_MASCHERPA_3MM_6020202101	4
BUSSOLA 5MA ANKOR BORGHINI X CERNIERA COLLO PIENO	8
MAGNETE FORZA MAGNETICA1-5 10KG_HAFELE_246.87.112	4

VERNICIATURA LASTRA/LACCATI:

● = FILI RASATI

● = VERNICIARE 1 LATO + FILI RASATI O BORDATI

NESSUN SIMBOLO = VERNICIARE 2 LATI + FILI RASATI O BORDATI

LOCALE	CODICE	DESCRIZIONE COMPONENTE	FINITURA	GR.
CABINA ARMATORE	MD320_R02_AA01	ARMADIO INGRESSO DX POPPA	LASTRA CHIARA	2

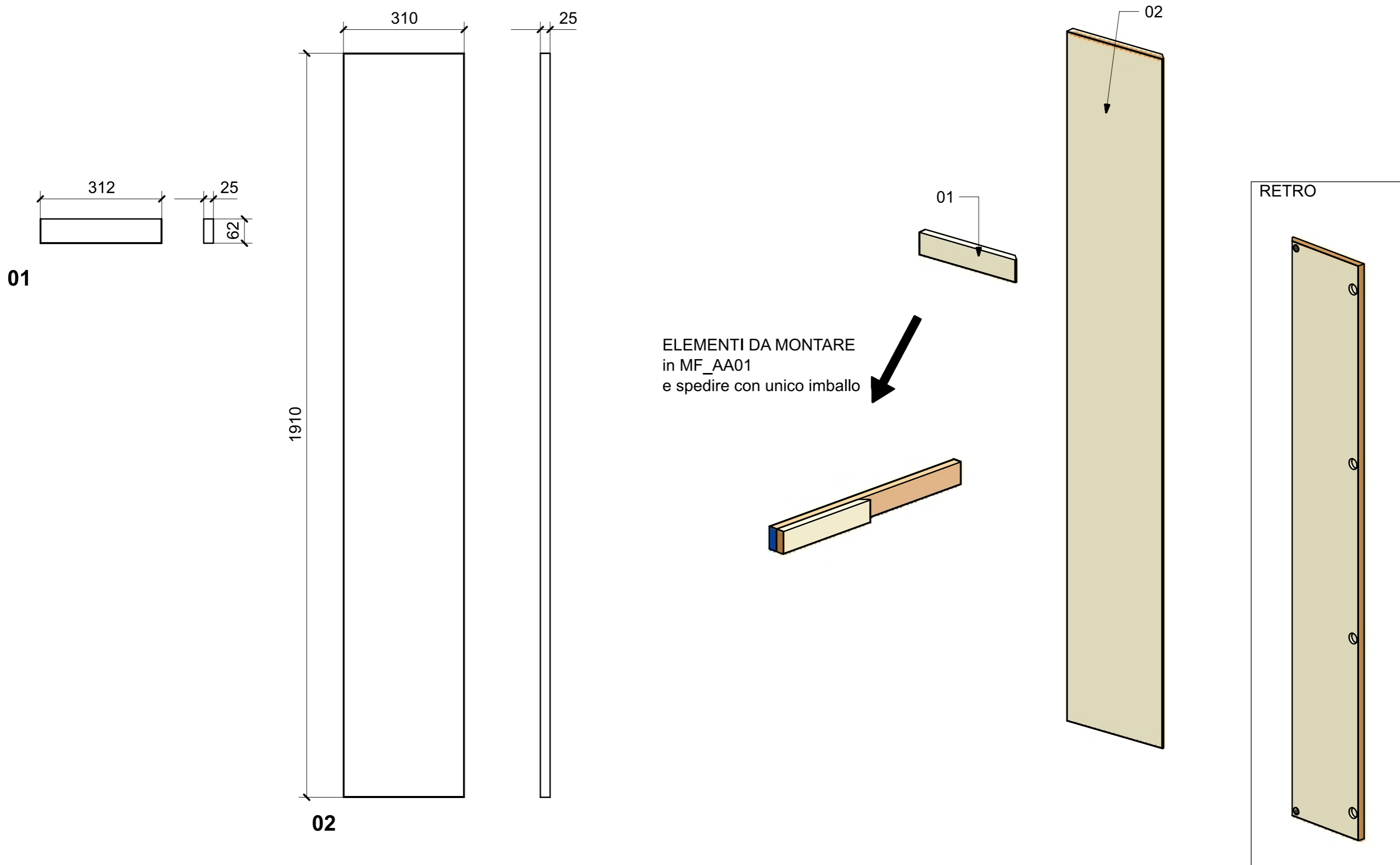

VERNICIATURA LASTRA/LACCATI:

● = FILI RASATI

● = VERNICIARE 1 LATO + FILI RASATI O BORDATI

NESSUN SIMBOLO = VERNICIARE 2 LATI + FILI RASATI O BORDATI

LOCALE	CODICE	DESCRIZIONE COMPONENTE	FINITURA	GR.
CABINA ARMATORE	MD320_R01_AB01	ARMADIO INGRESSO SX POPPA	LASTRA SCURA	2

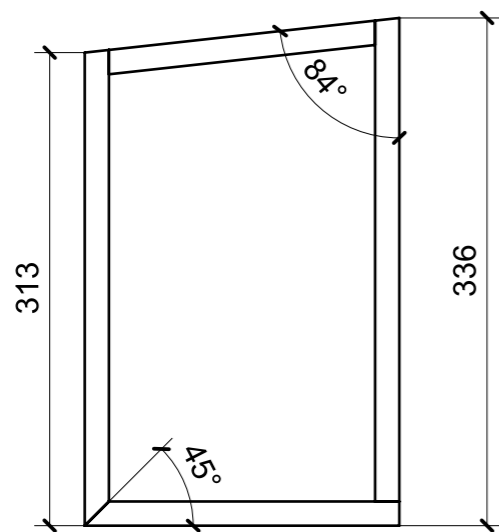
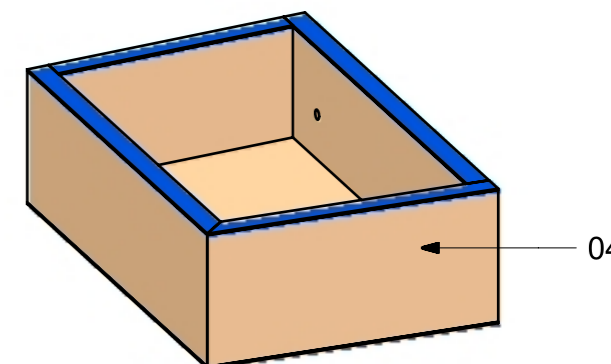
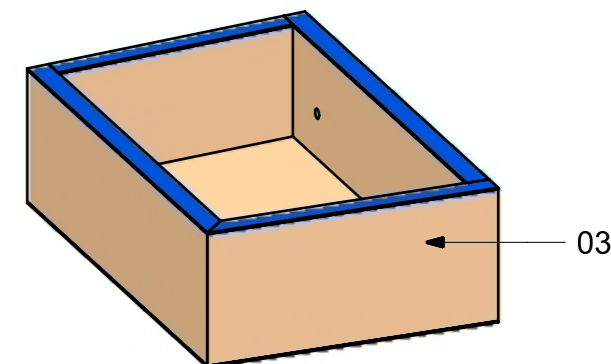
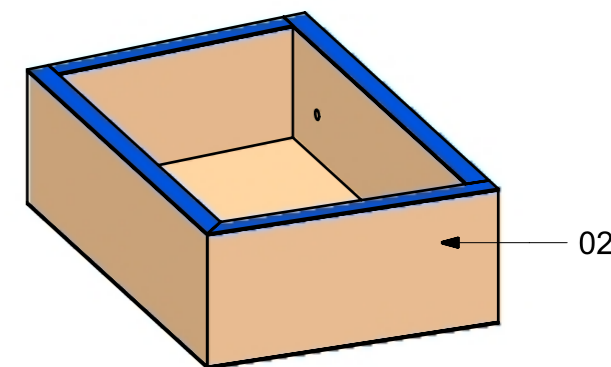
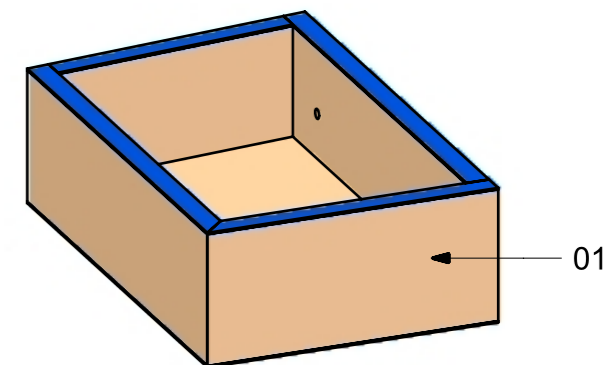
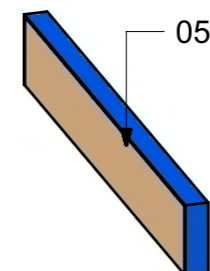
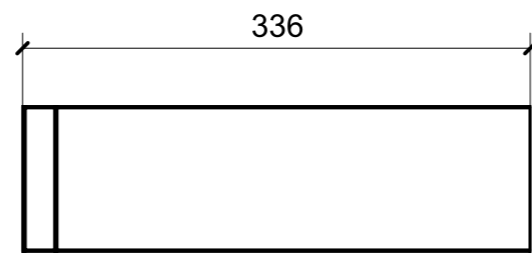
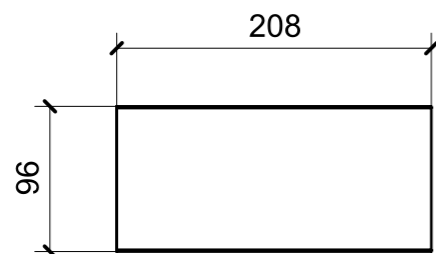

01 - 02 - 03 - 04

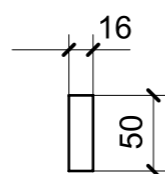
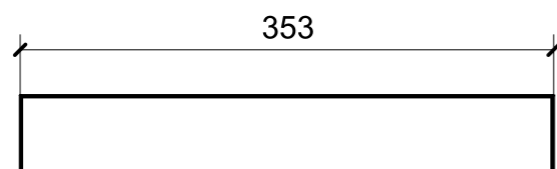

05

VERNICIATURA LASTRA/LACCATI:

● = VERNICIARE 1 LATO + FILI RASATI O BORDATI

NESSUN SIMBOLO = VERNICIARE 2 LATI + FILI RASATI O BORDATI

LOCALE	CODICE	DESCRIZIONE COMPONENTE	FINITURA	GR.
CABINA ARMATORE	MD320_R02_AB01	ARMADIO INGRESSO SX POPPA	LASTRA CHIARA	2

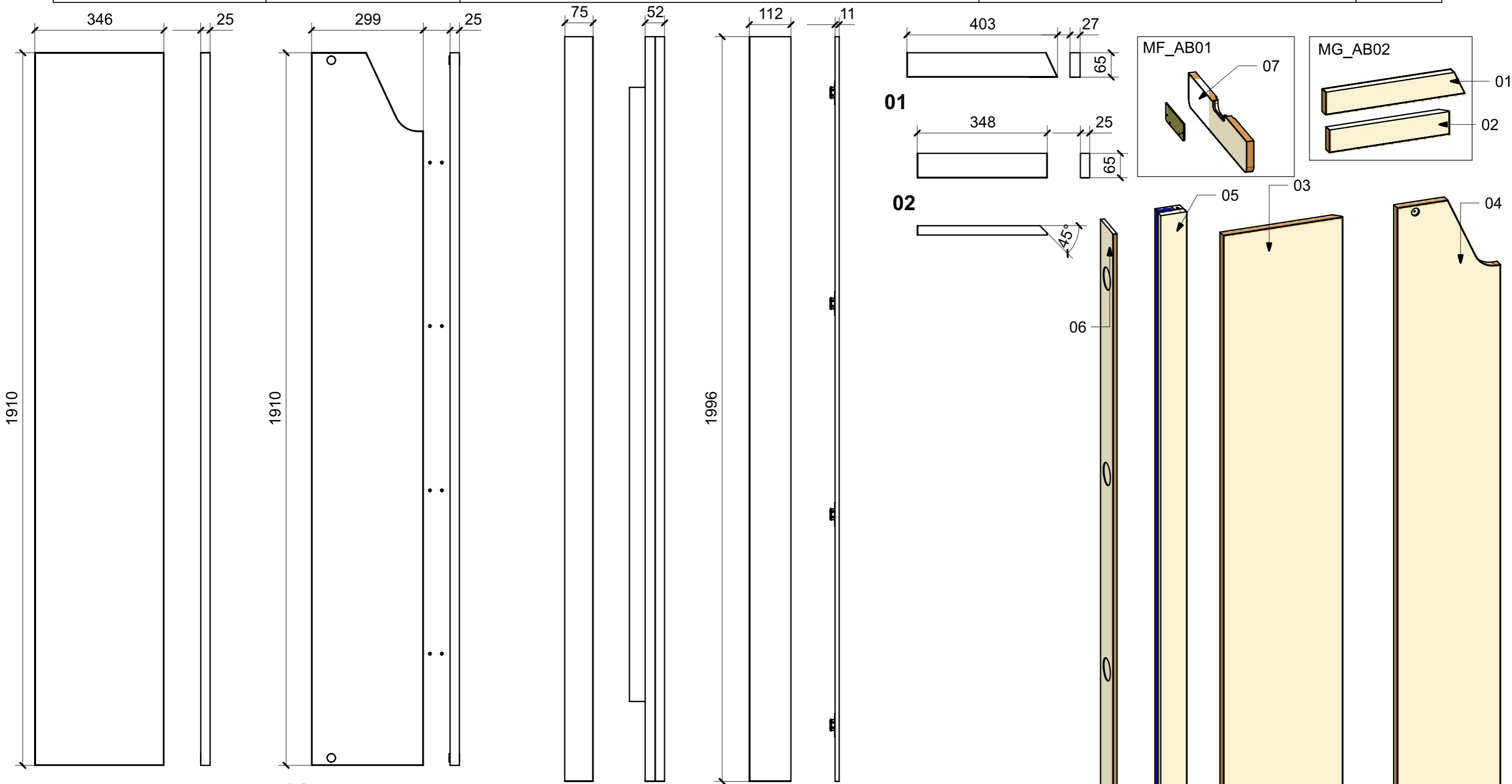

03 **04** **05** **06** **07**

FERRAMENTA	QTY
BASE_3-NERA_HAFELE_342.22.067-BLUM_175H3130.STP	4
BUSSOLA 5MA ANKOR BORGHI X CERNIERA COLLO PIENO	16
CERNIERA 155°_MEZZO COLLO-NERA_BLUM_71B7650_ONS	4
CERNIERA 94°_PIANA-NERA_HAFELE_342.46.604-BLUM_71B9550.STP	4
FITLOCK M_MASCHERPA_3MM_6020202101	4
MAGNETE FORZA MAGNETICA1-5 10KG_HAFELE_246.87.112	6
VITE 4MAX8 ANKOR BORGHI	8

NESSUN SIMBOLO = VERNICIARE 2 LATI + FILI RASATI O BORDATI
 = VERNICIARE 1 LATO + FILI RASATI O BORDATI

VERNICIATURA LASTRA/LACCATI:

LOCALE	CODICE	DESCRIZIONE COMPONENTE	FINITURA	GR.
CABINA ARMATORE	MD320_R01_AC01	MURATA DX POPPA	LASTRA SCURA	2

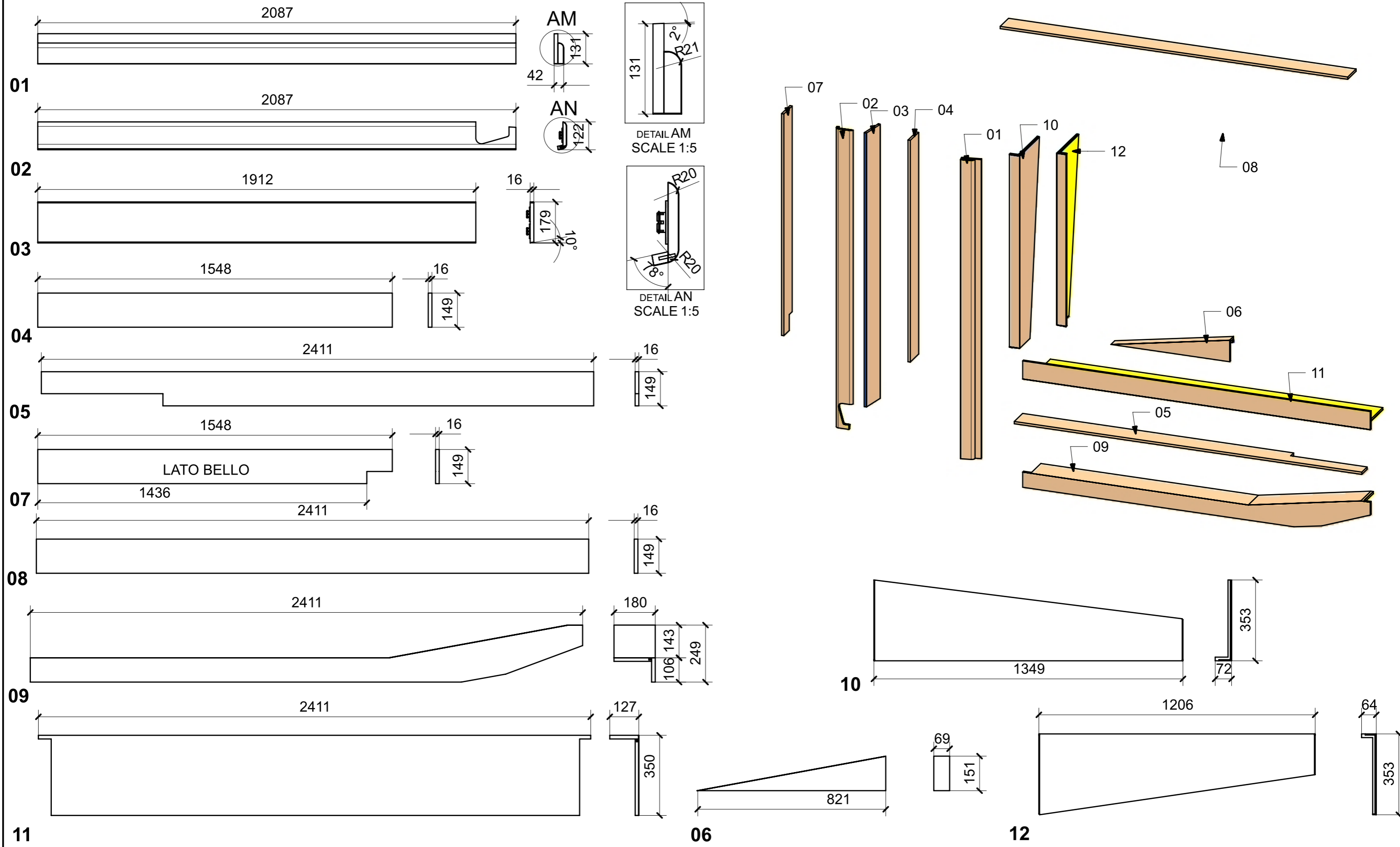

LOCALE	CODICE	DESCRIZIONE COMPONENTE	FINITURA	GR.
CABINA ARMATORE	MD320_R02_AC01	MURATA DX POPPA	LASTRA CHIARA	PTP

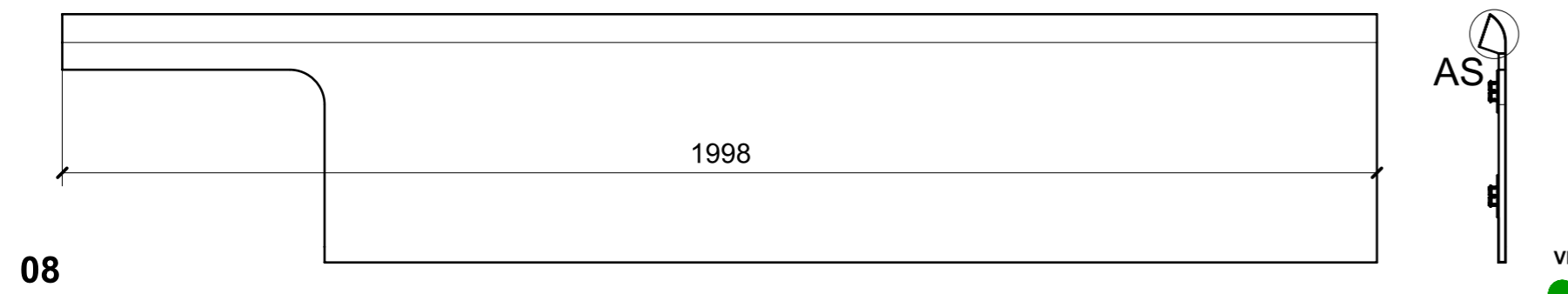
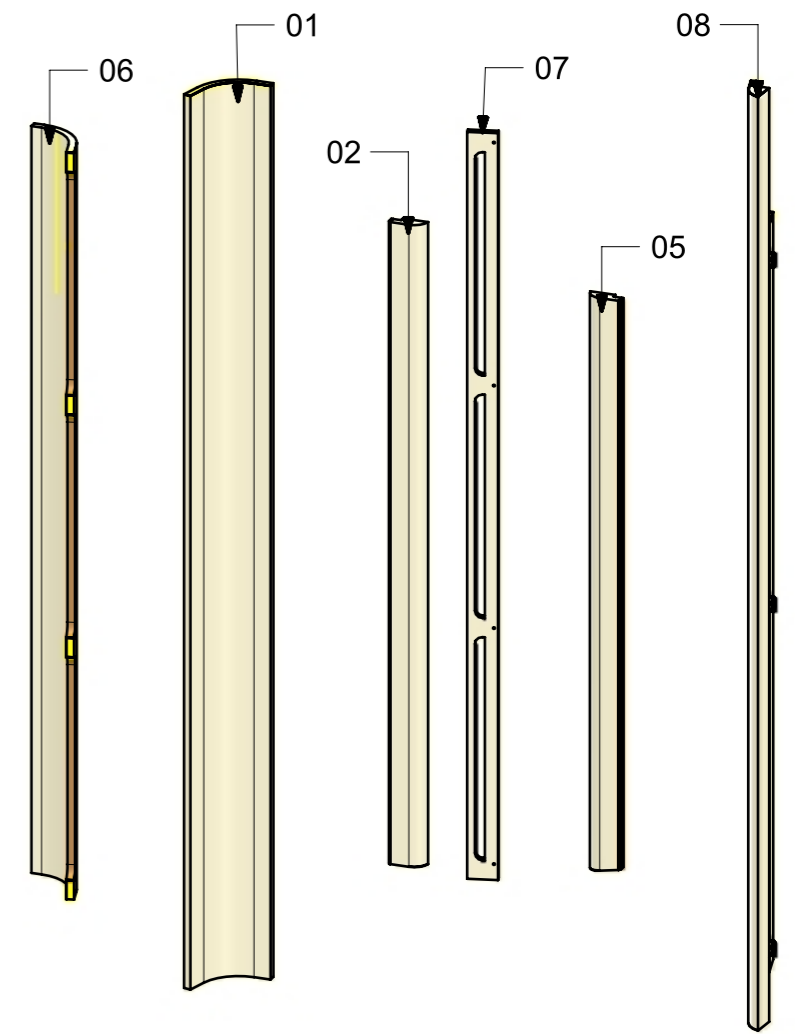
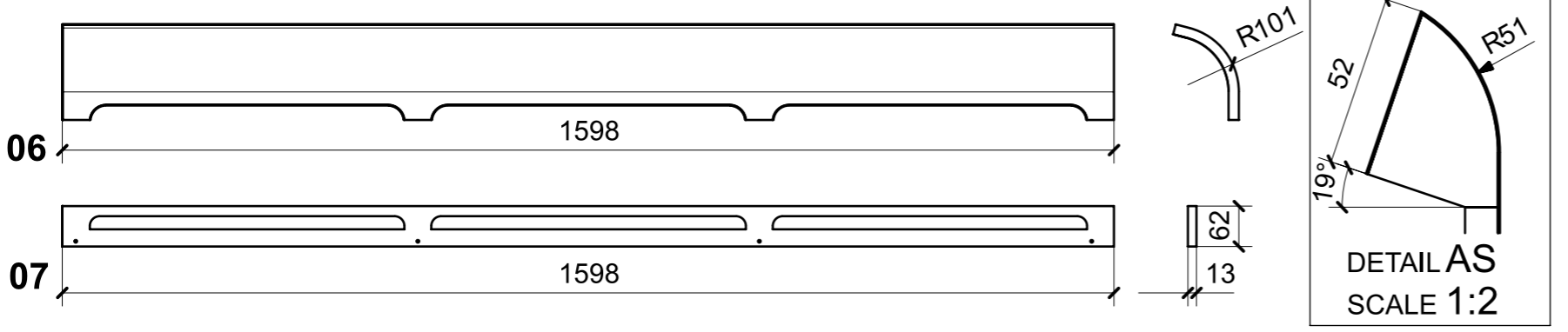
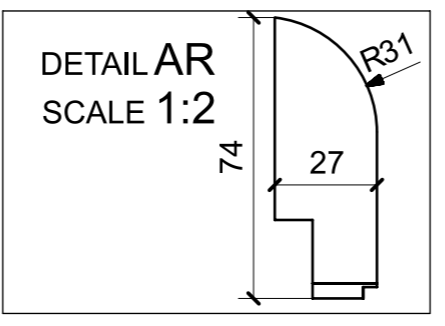
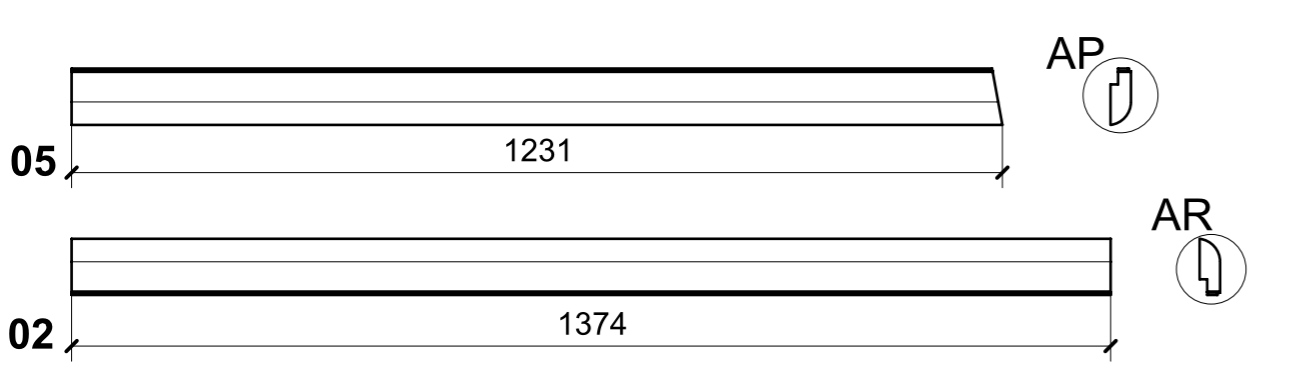
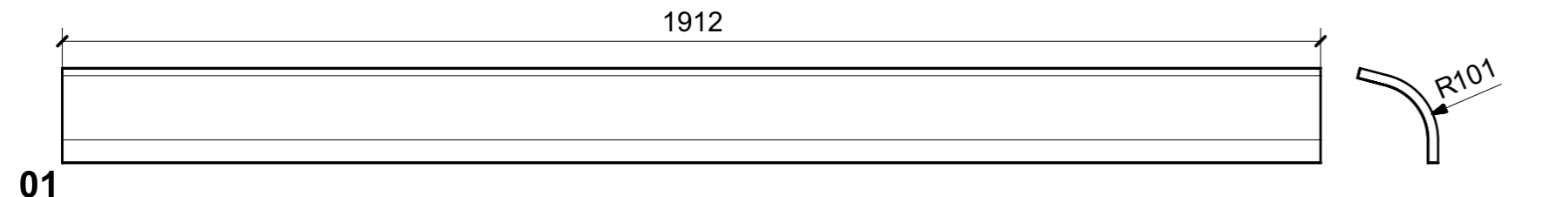
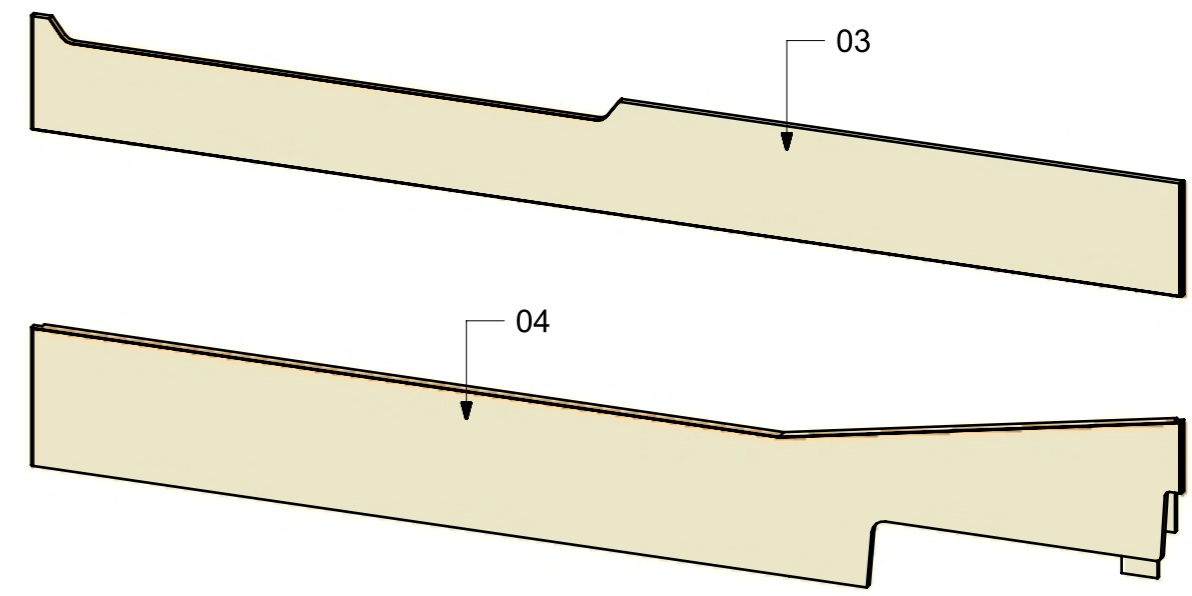
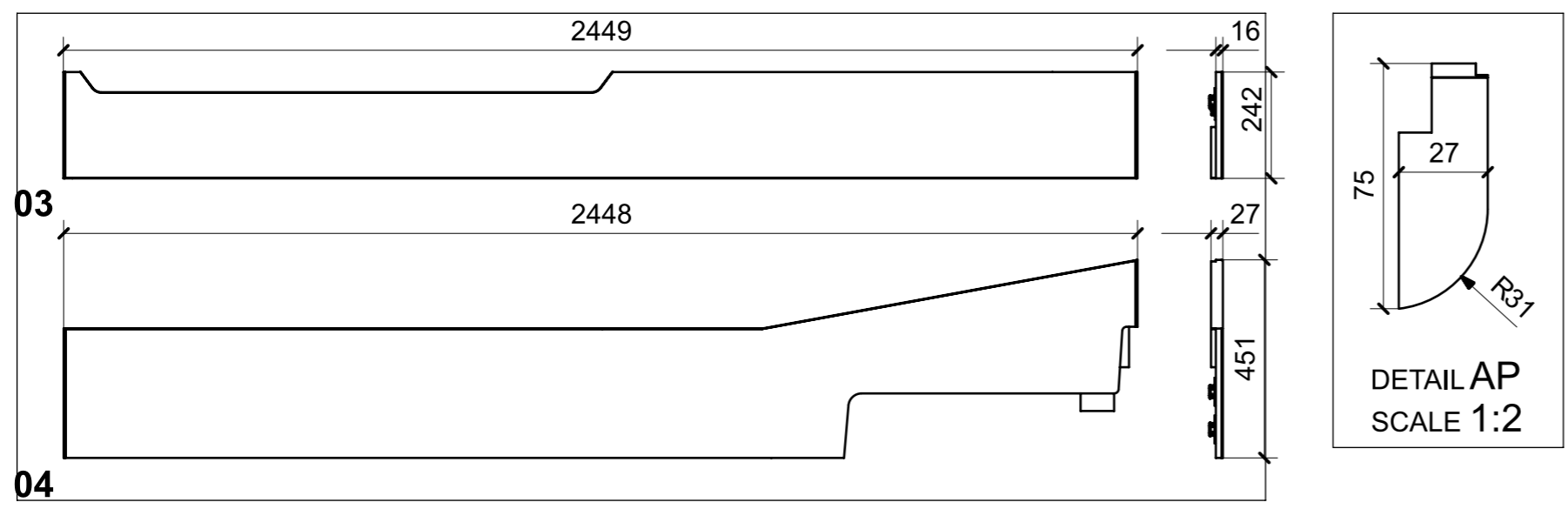

VERNICIATURA LASTRA/LACCATI:
 ● = VERNICIARE 1 LATO + FILI RASATI O BORDATI NESSUN SIMBOLO = VERNICIARE 2 LATI + FILI RASATI O BORDATI

LOCALE	CODICE	DESCRIZIONE COMPONENTE	FINITURA	GR.
CABINA ARMATORE	MD320_R01_AD01	MURATA SX POPPA	LASTRA SCURA	2

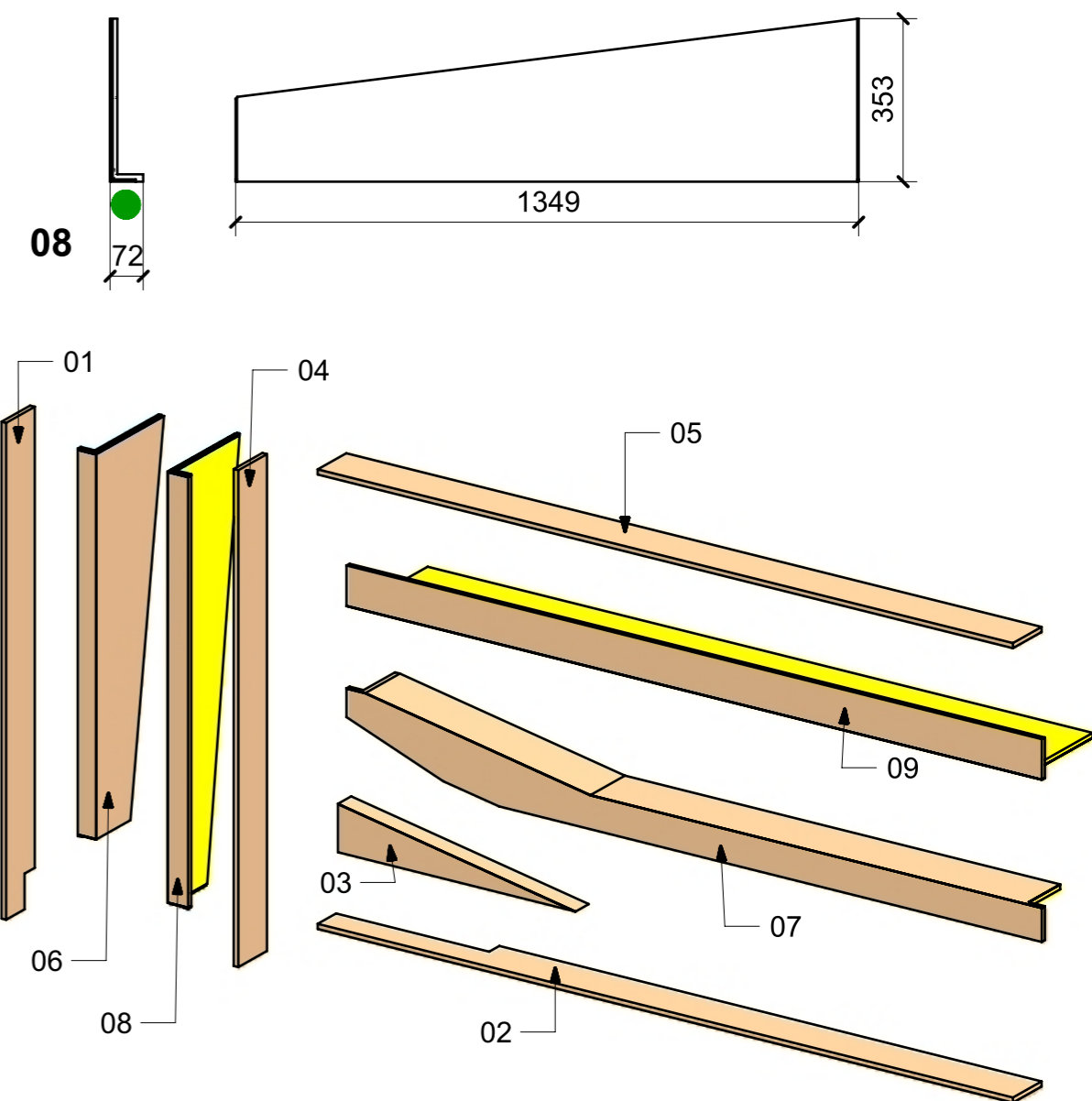
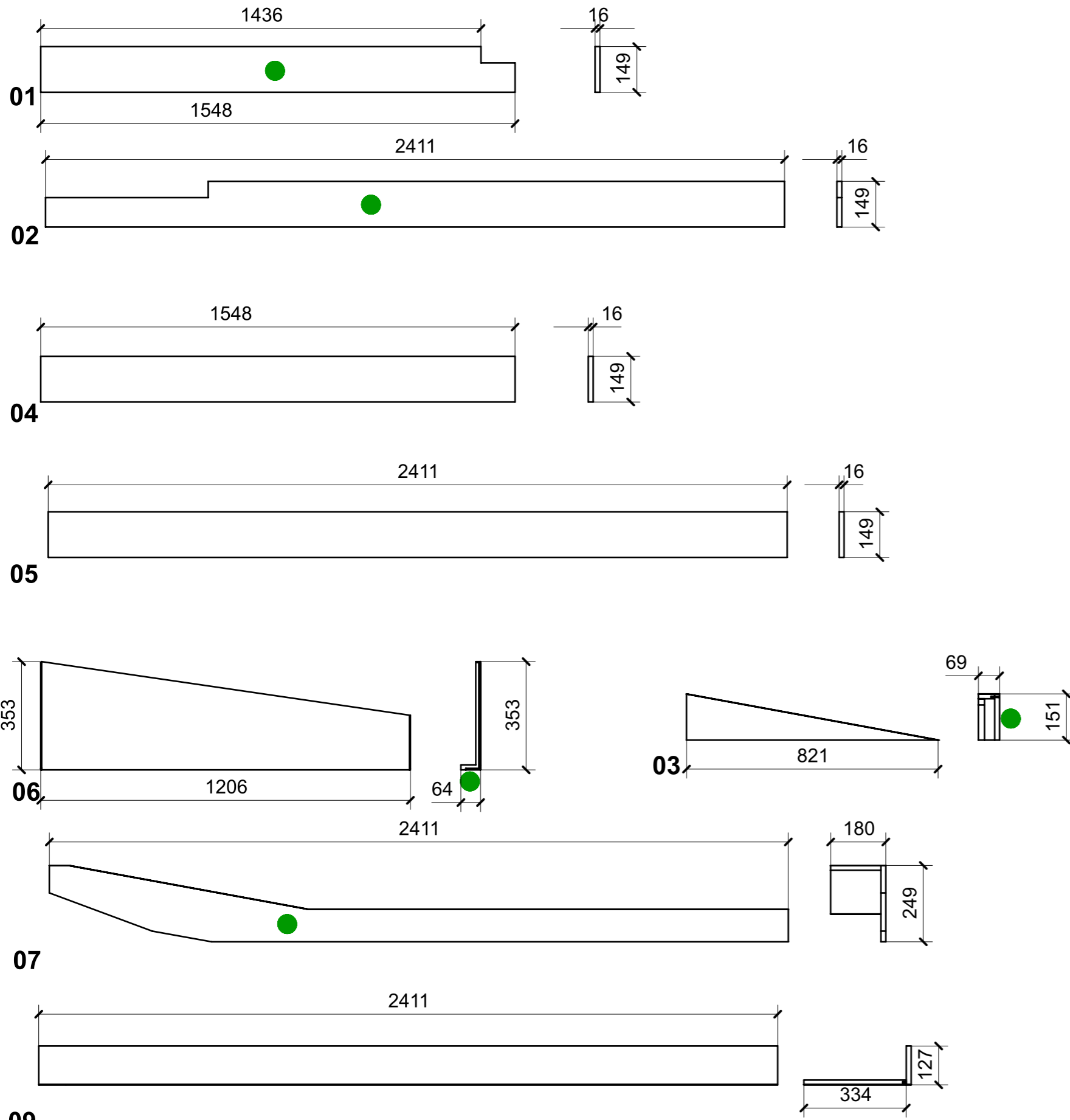

FERRAMENTA	QTY
VITE 6MA X 25 TESTA BOMBATA	10
VITE 6MA X 25 TESTA SVASATA	5
FITLOCK F_MINI	4
BUSSOLA 6MA X 10 FORO DIAM.8	11
FITLOCK F_MASCHERPA_6020101102	24
FITLOCK M_MINI	4
FITLOCK M_MASCHERPA_3MM_6020202101	24

VERNICIATURA LASTRA/LACCATI:
 ● = VERNICIARE 1 LATO + FILI RASATI O BORDATI NESSUN SIMBOLO = VERNICIARE 2 LATI + FILI RASATI O BORDATI

LOCALE	CODICE	DESCRIZIONE COMPONENTE	FINITURA	GR.
CABINA ARMATORE	MD320_R02_AD01	MURATA SX POPPA	LASTRA CHIARA	2

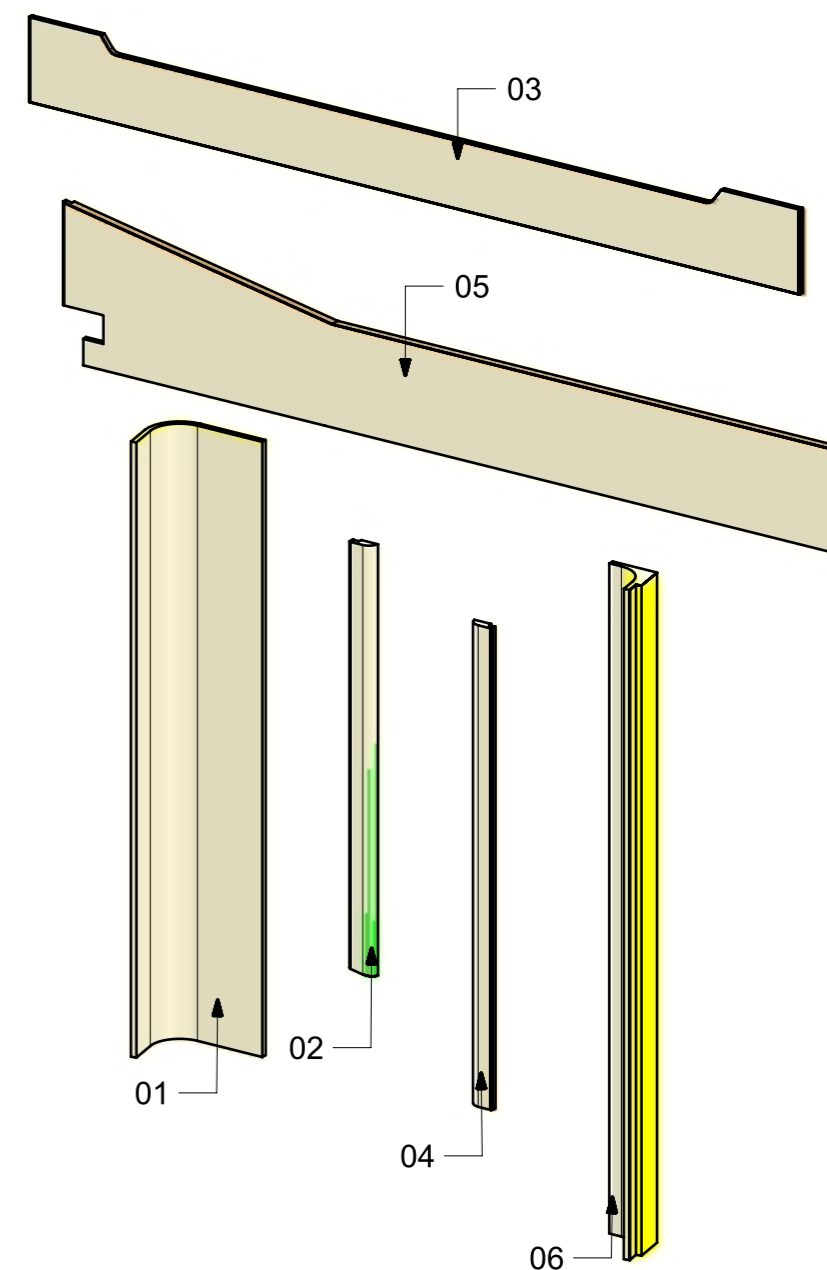
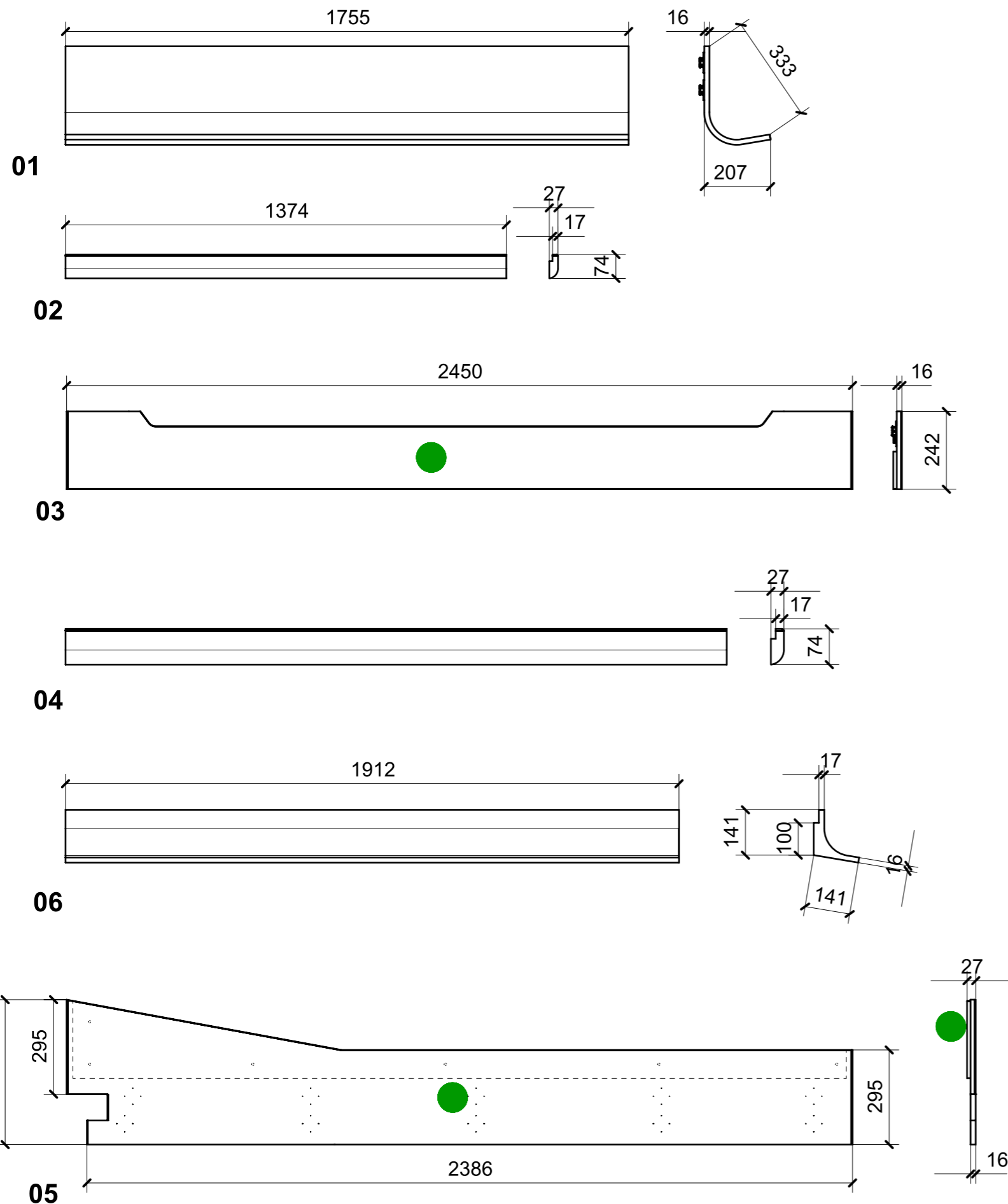

FERRAMENTA	QTY
BUSSOLA 6MA X 10 FORO DIAM.8	11
FITLOCK F_MASCHERPA_6020101102	24
FITLOCK F_MINI	4
FITLOCK M_MASCHERPA_3MM_6020202101	48
FITLOCK M_MINI	8
VITE 6MA X 25 TESTA SVASATA	5
VITE 6MA X 25 TESTA BOMBATA	10

VERNICIATURA LASTRA/LACCATI:

● = VERNICIARE 1 LATO + FILI RASATI O BORDATI

NESSUN SIMBOLO = VERNICIARE 2 LATI + FILI RASATI O BORDATI

LOCALE	CODICE	DESCRIZIONE COMPONENTE	FINITURA	GR.
CABINA ARMATORE	MD320_R01_AE01	PARETE TV CENTRO NAVE	LASTRA SCURA	PTP

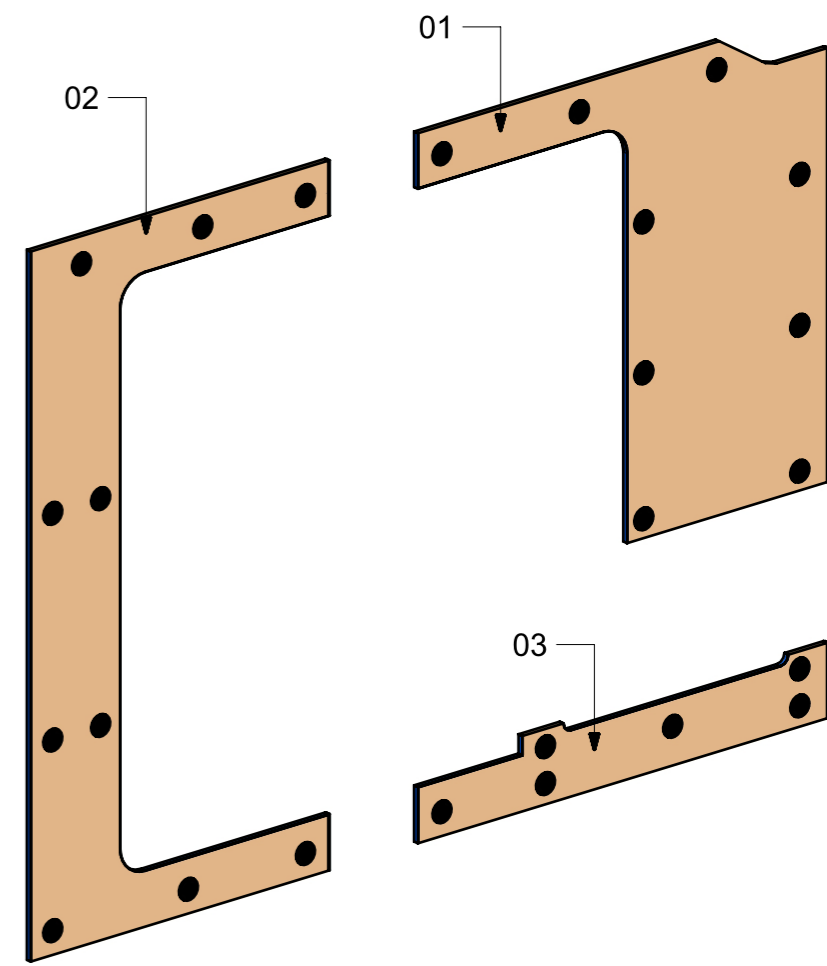
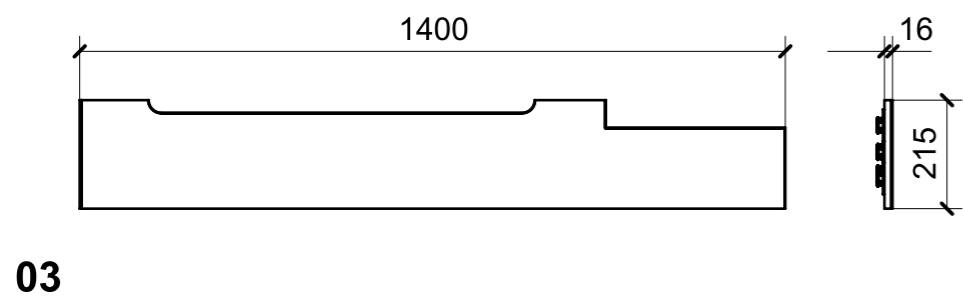
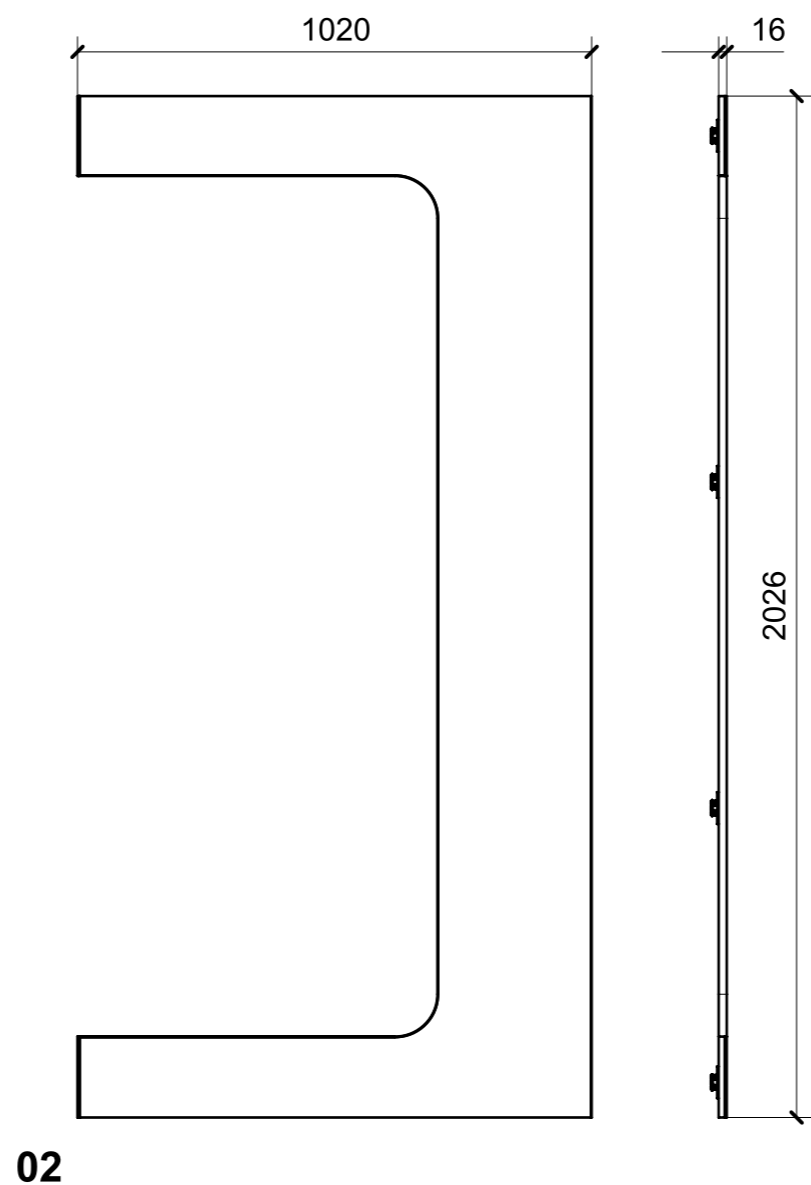
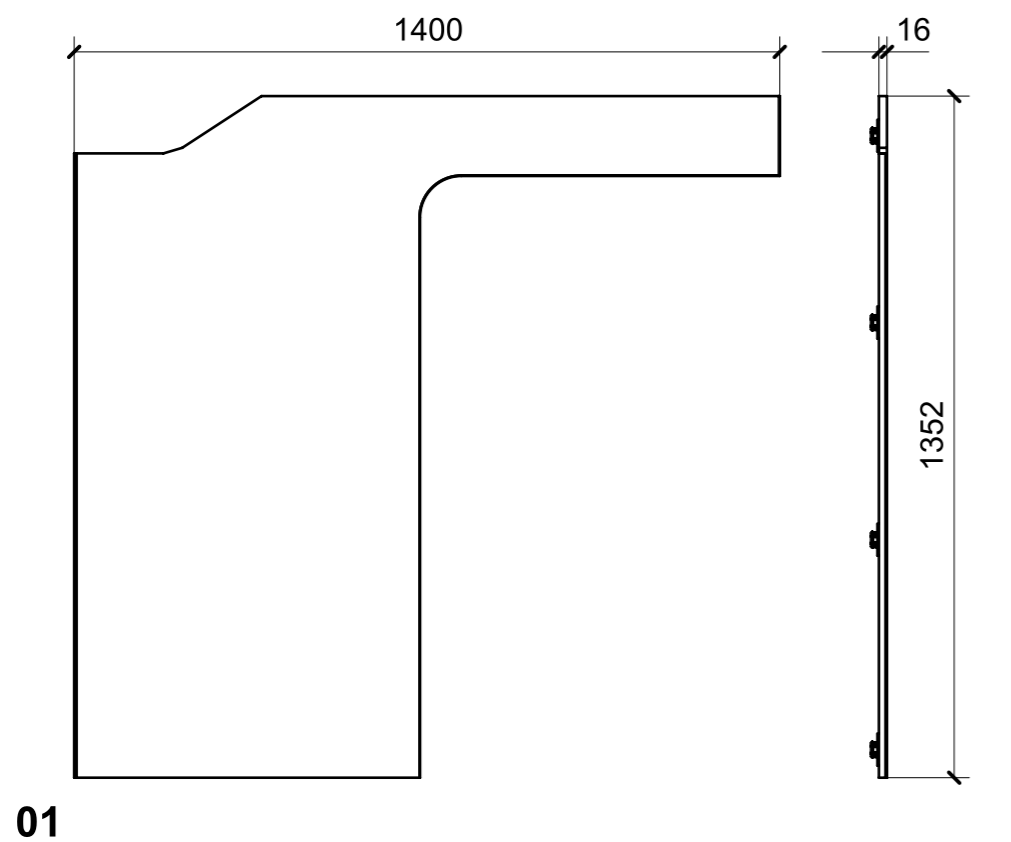

FERRAMENTA	QTY
FITLOCK M_MASCHERPA_3MM_6020202101	25

● = FILI RASATI ● = VERNICIARE 1 LATO + FILI RASATI O BORDATI NESSUN SIMBOLO = VERNICIARE 2 LATI + FILI RASATI O BORDATI

LOCALE	CODICE	DESCRIZIONE COMPONENTE	FINITURA	GR.
CABINA ARMATORE	MD320_R01_AF01	MOBILE SOSPESO ZONA TV	LASTRA SCURA	2

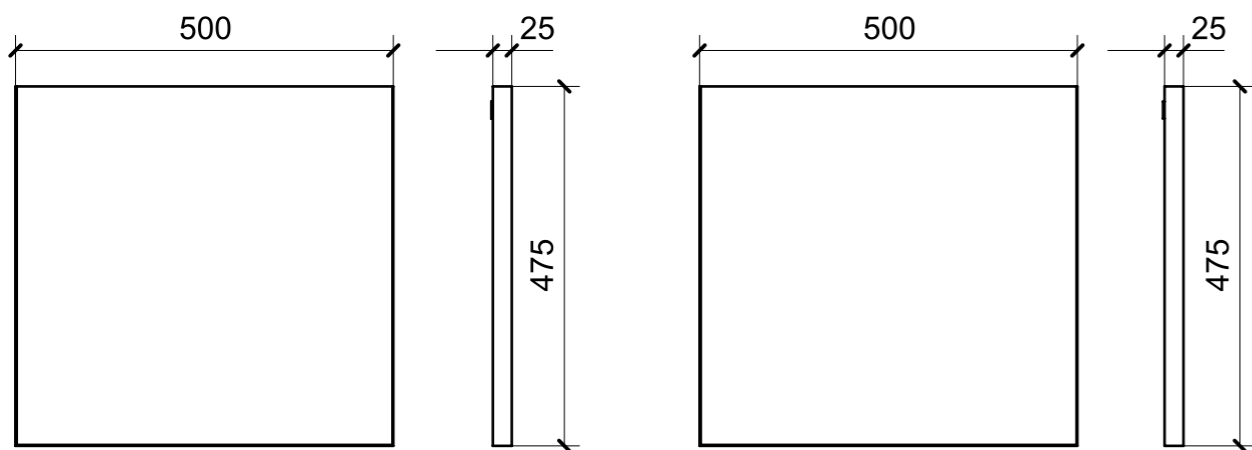

01

02

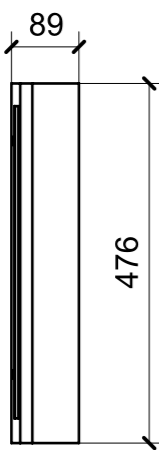
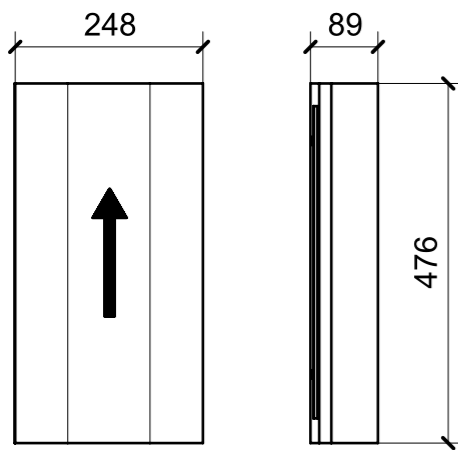
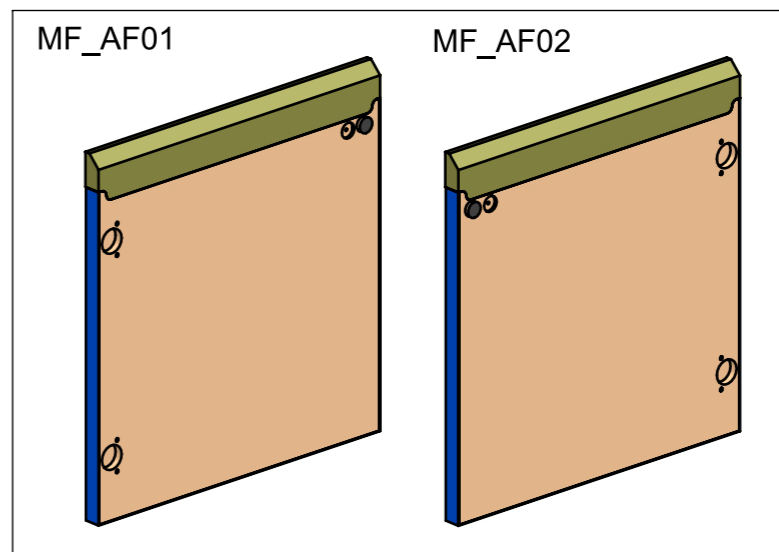

IMPIALLACCIARE TESTE E TUTTI I FILI (TRANNE QUI ALL'INTERO)

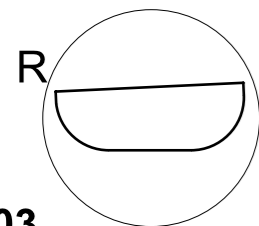
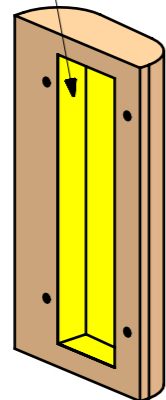

03

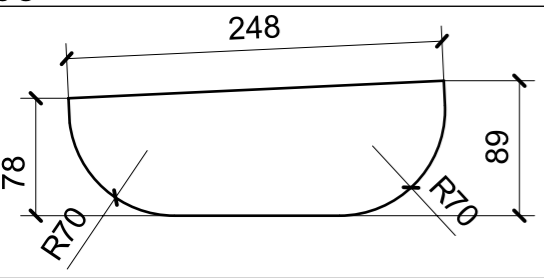

DETAIL R
SCALE 1:5

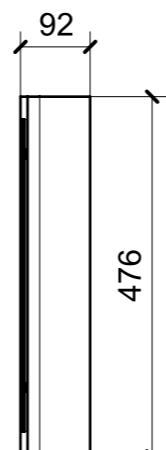
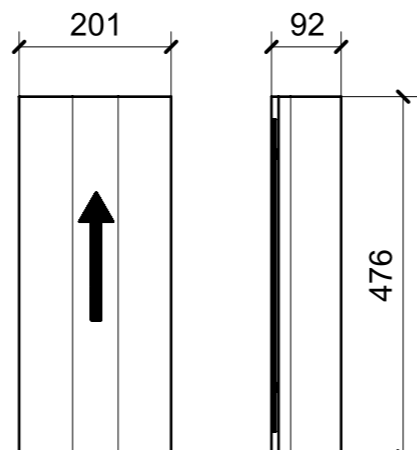

IMPIALLACCIARE TESTE E TUTTI I FILI (TRANNE ALL'INTERO)

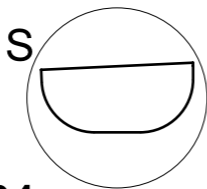
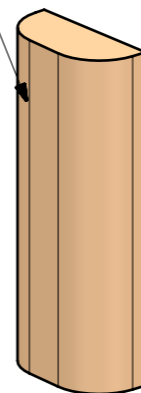

04

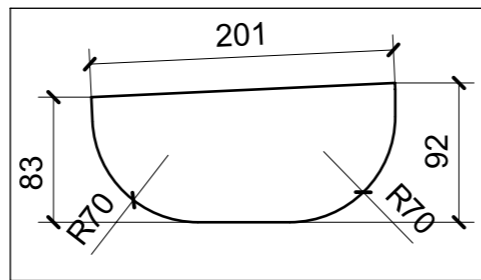

DETAIL S
SCALE 1:5

ELEMENTI DA MONTARE in MF_AF01 \ AF02 e spedire con unico imballo

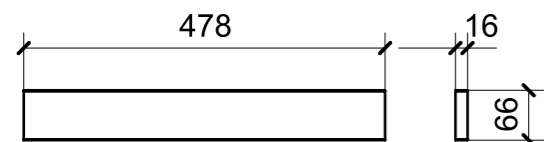
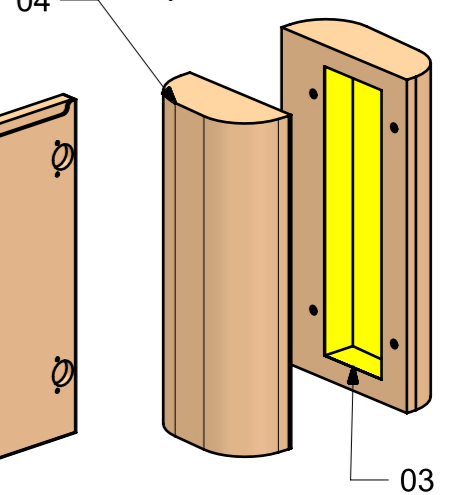
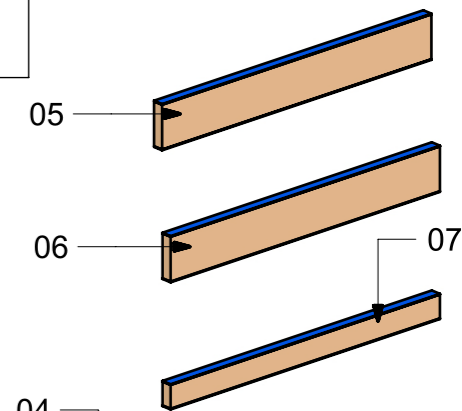

05

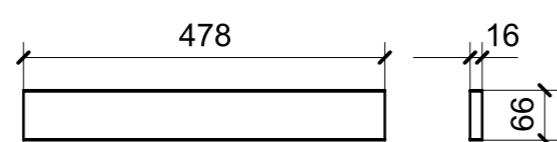

06

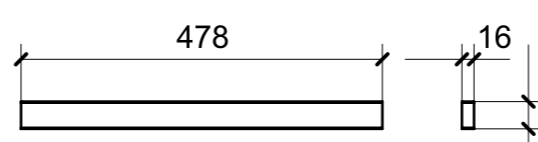

07

FERRAMENTA	QTY
BUSSOLA 5MA ANKOR BORGHI X CERNIERA COLLO PIENO	8
MAGNETE FORZA MAGNETICA1-5 10KG_HAFELE_246.87.112	2

VERNICIATURA LASTRA/LACCATI:

● = FILI RASATI

● = VERNICIARE 1 LATO + FILI RASATI O BORDATI

NESSUN SIMBOLO = VERNICIARE 2 LATI + FILI RASATI O BORDATI

LOCALE	CODICE	DESCRIZIONE COMPONENTE	FINITURA	GR.
CABINA ARMATORE	MD320_R01_AG01	TESTATA LETTO	LASTRA SCURA	2

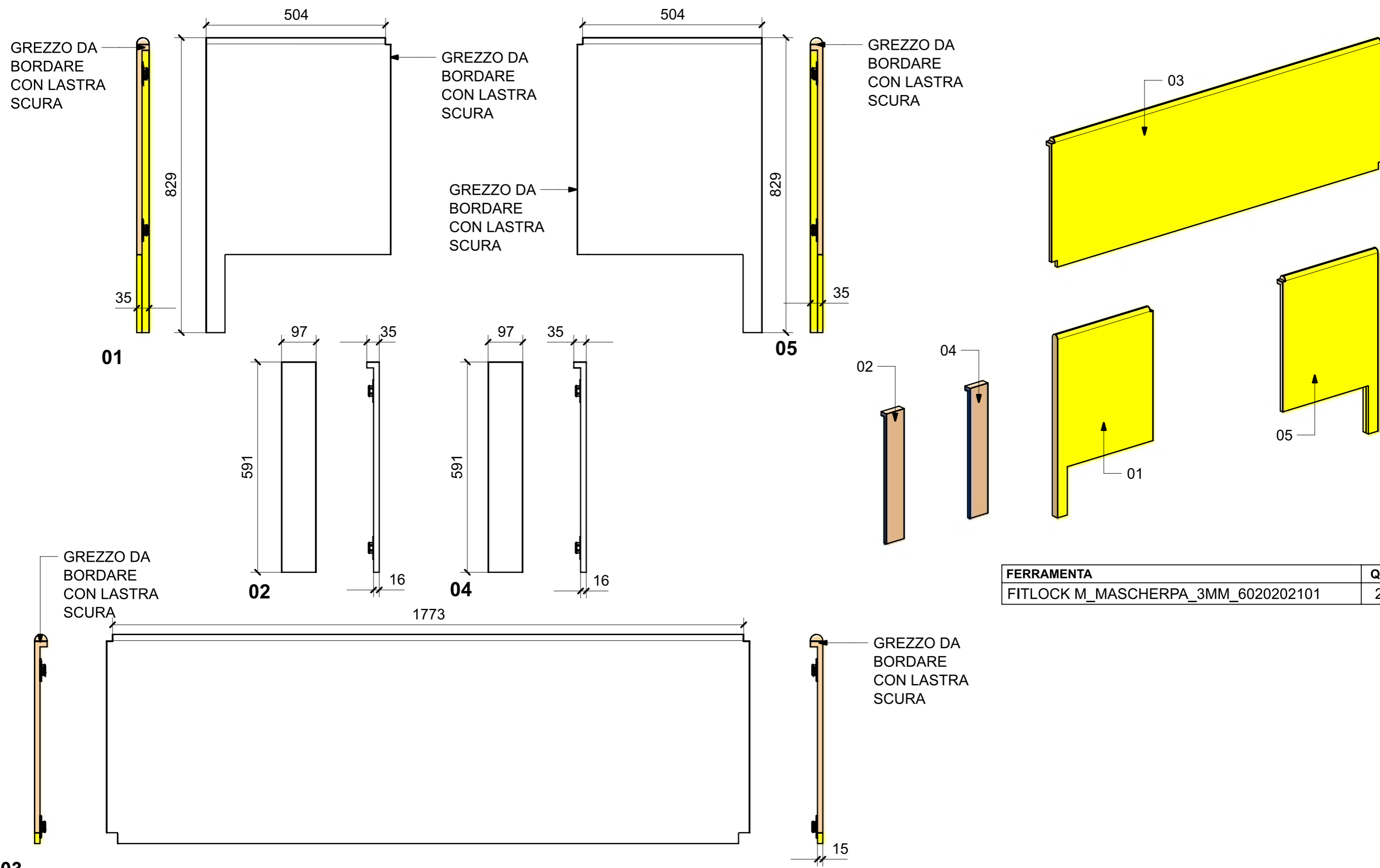

FERRAMENTA	QTY
FITLOCK M_MASCHERPA_3MM_6020202101	20

03

VERNICIATURA LASTRA/LACCATI:

● = VERNICIARE 1 LATO + FILI RASATI O BORDATI

NESSUN SIMBOLO = VERNICIARE 2 LATI + FILI RASATI O BORDATI

LOCALE	CODICE	DESCRIZIONE COMPONENTE	FINITURA	GR.
CABINA ARMATORE	MD320_R02_AG01	TESTATA LETTO	LASTRA CHIARA	2

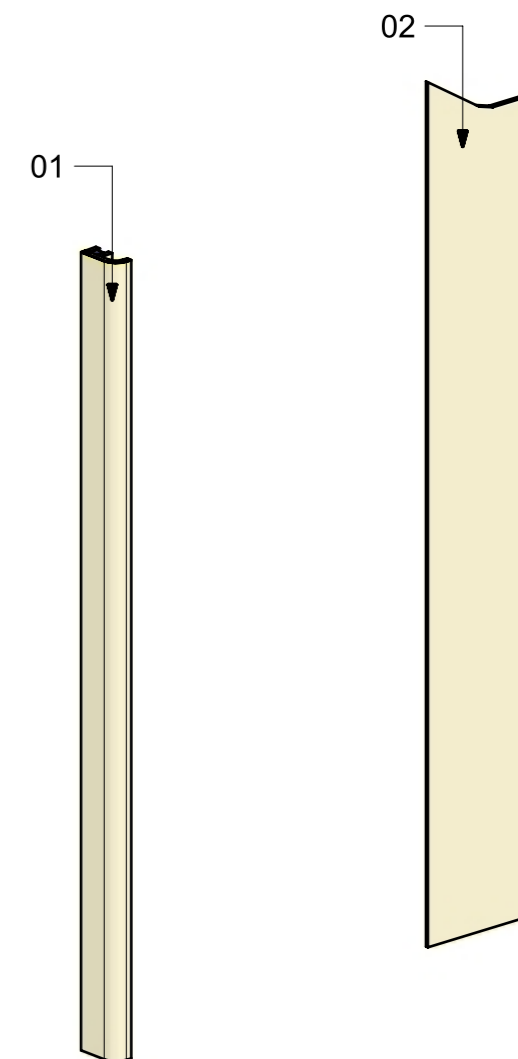
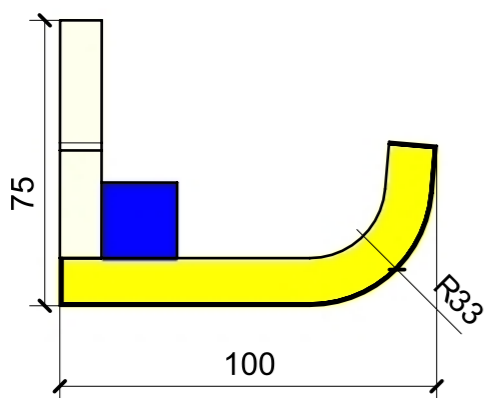
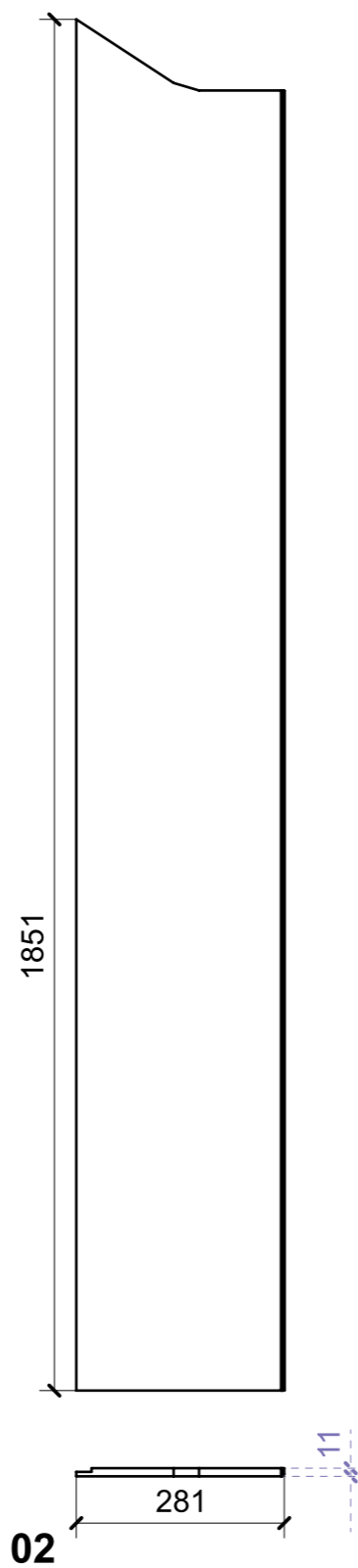
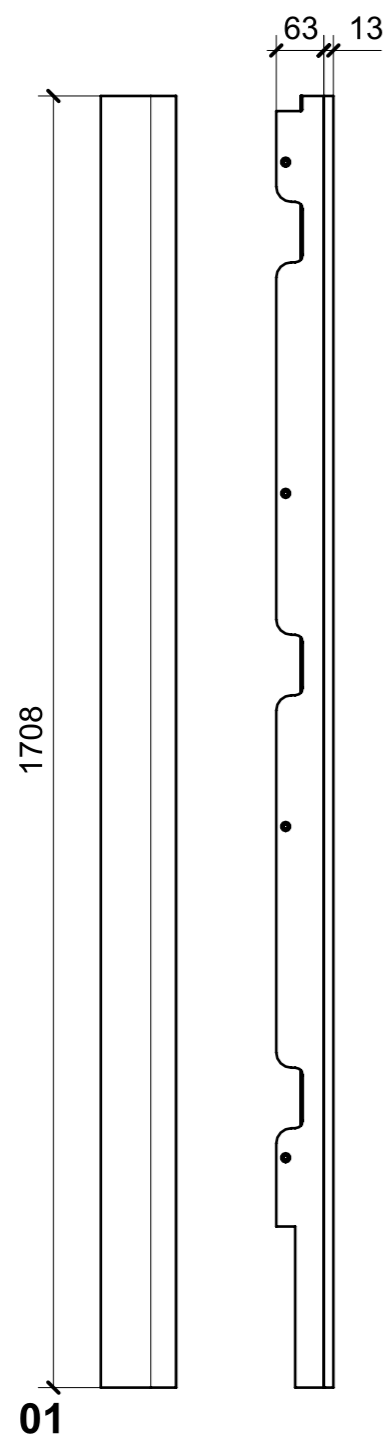

VERNICIATURA LASTRA/LACCATI:

● = VERNICIARE 1 LATO + FILI RASATI O BORDATI

NESSUN SIMBOLO = VERNICIARE 2 LATI + FILI RASATI O BORDATI

LOCALE	CODICE	DESCRIZIONE COMPONENTE	FINITURA	GR.
CABINA ARMATORE	MD320_R02_AM01	GRADINI GREZZI ARMATORE	LASTRA CHIARA	2

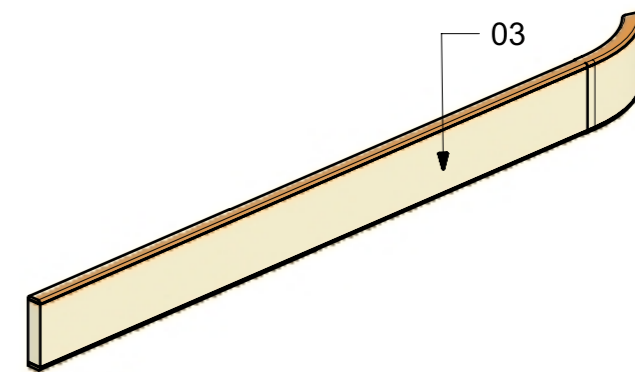
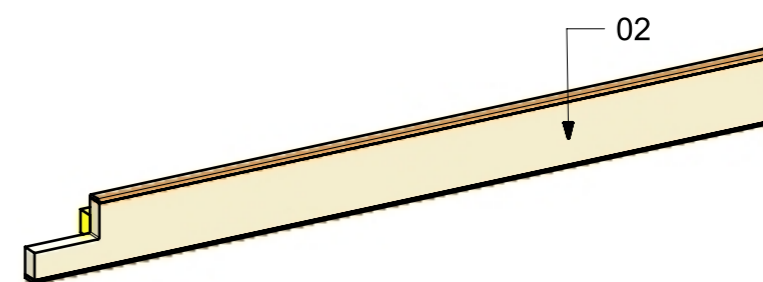
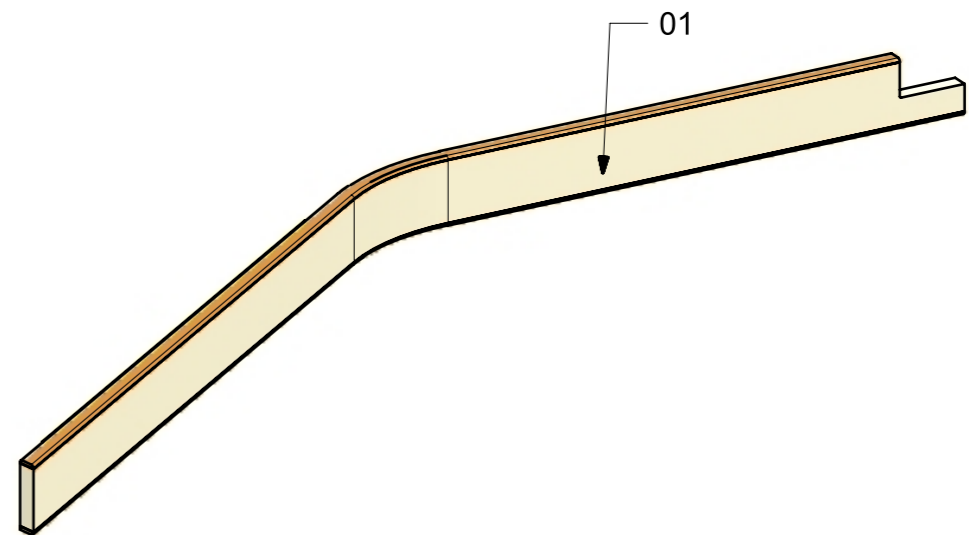
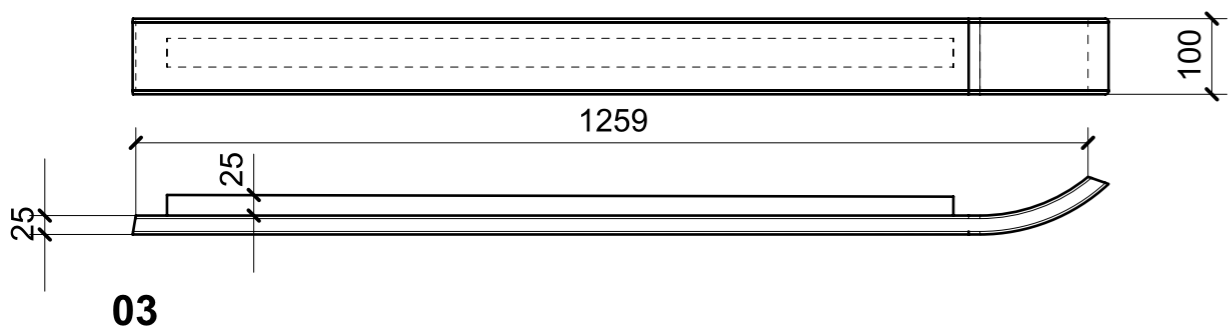
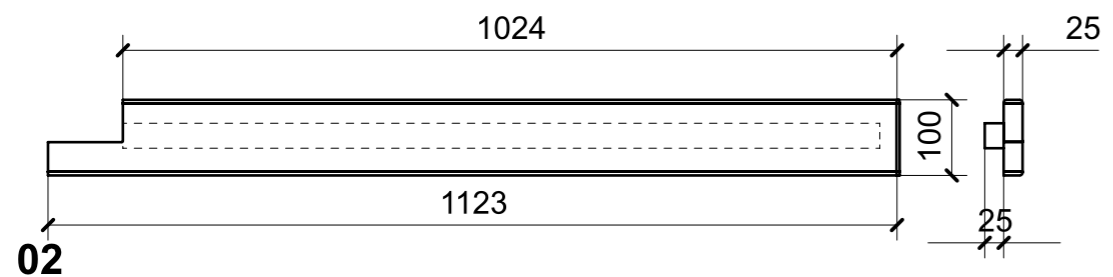
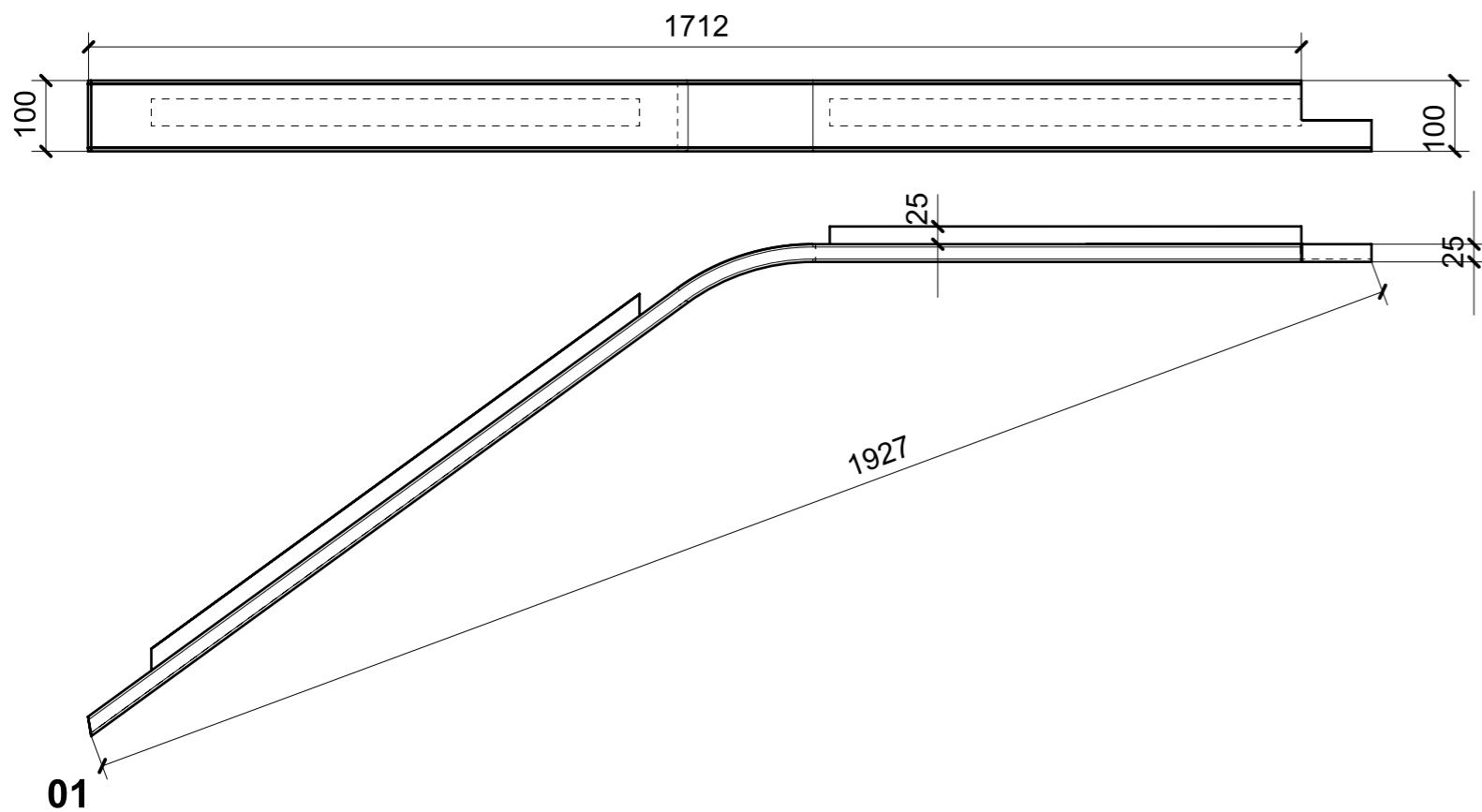

VERNICIATURA LASTRA/LACCATI:

● = VERNICIARE 1 LATO + FILI RASATI O BORDATI

NESSUN SIMBOLO = VERNICIARE 2 LATI + FILI RASATI O BORDATI

LOCALE	CODICE	DESCRIZIONE COMPONENTE	FINITURA	GR.
CABINA ARMATORE	MD320_R01_AR01	ARMADIO DRESSING PRUA	LASTRA SCURA	2

4 PEZZI UGUALI

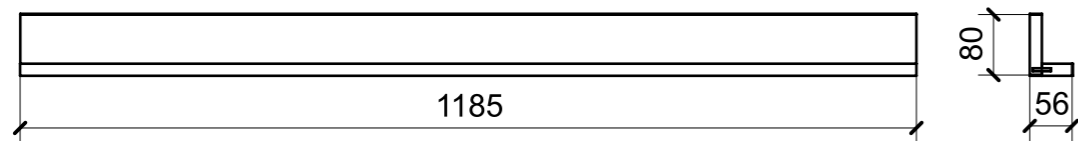

01 02 03 04

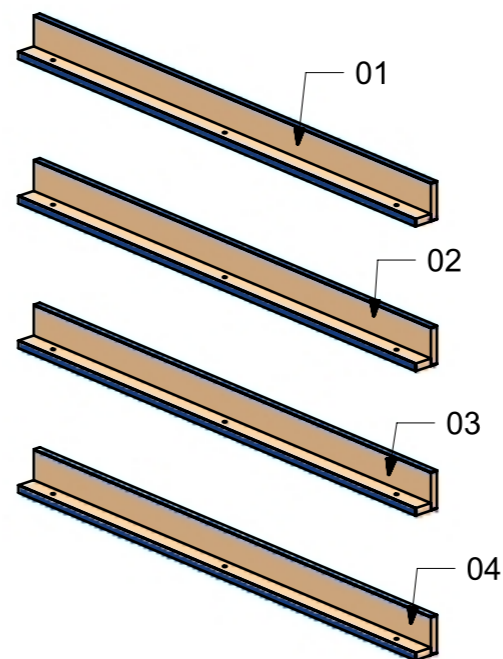

6 PEZZI UGUALI

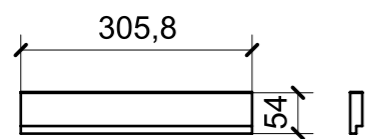

05

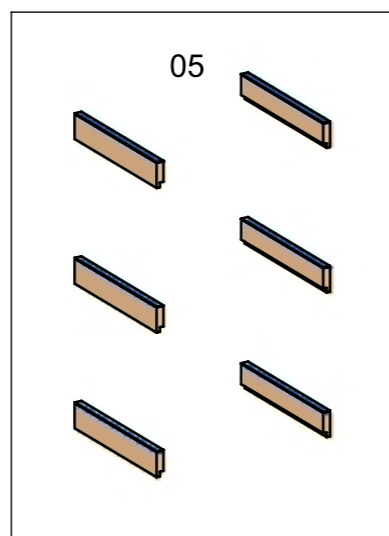

2 PEZZI UGUALI

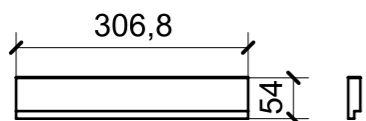

06

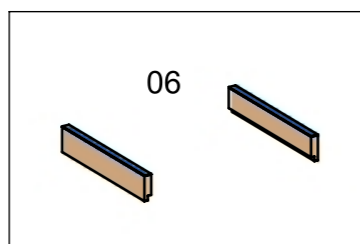

VERNICIATURA LASTRA/LACCATI:

● = FILI RASATI

● = VERNICIARE 1 LATO + FILI RASATI O BORDATI

NESSUN SIMBOLO = VERNICIARE 2 LATI + FILI RASATI O BORDATI

LOCALE	CODICE	DESCRIZIONE COMPONENTE	FINITURA	GR.
CABINA ARMATORE	MD320_R02_AR01	ARMADIO DRESSING PRUA	LASTRA CHIARA	2

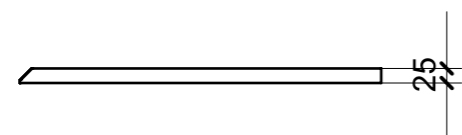
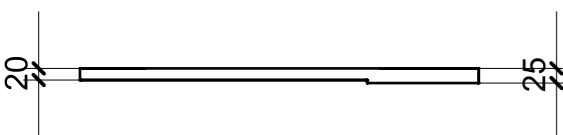
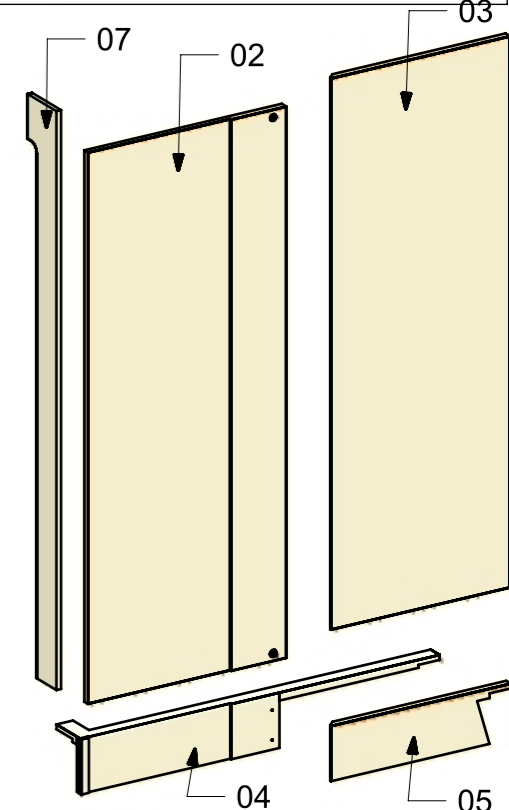
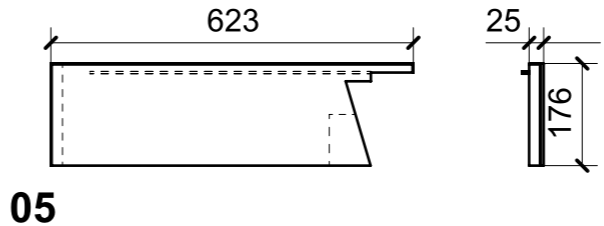
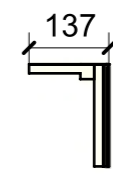
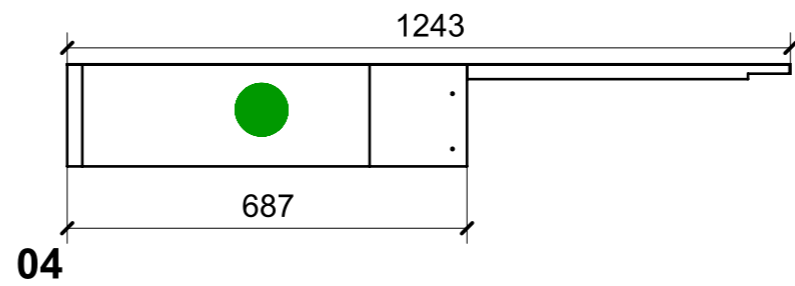
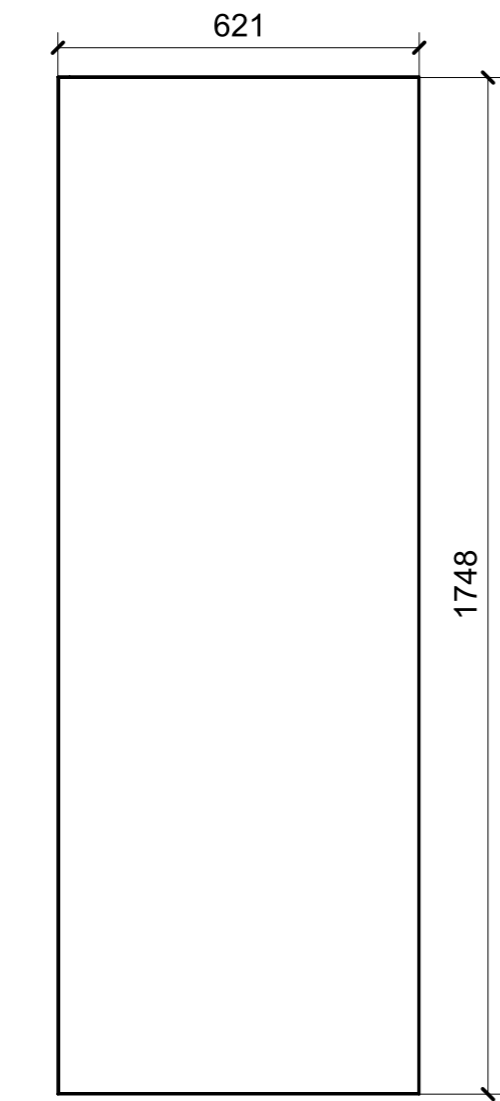
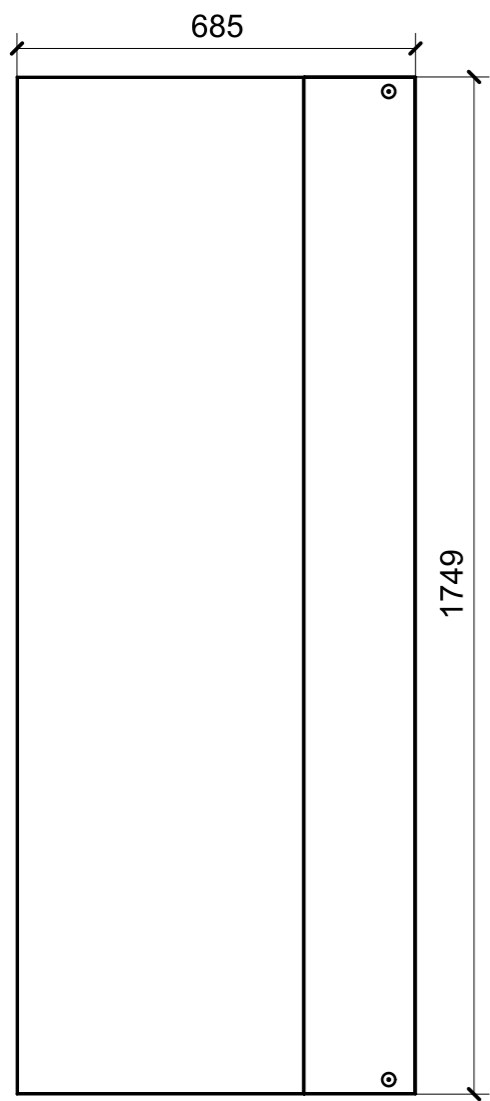
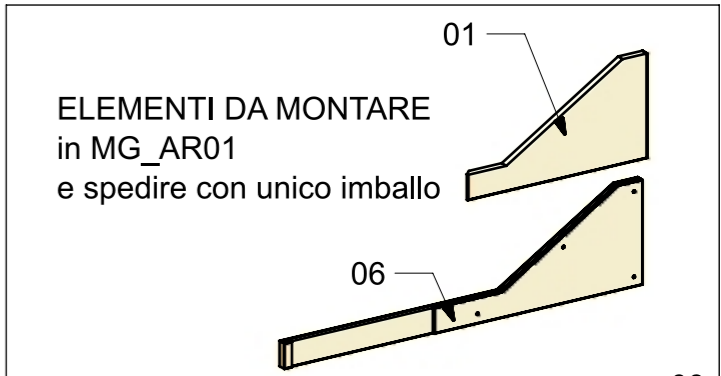
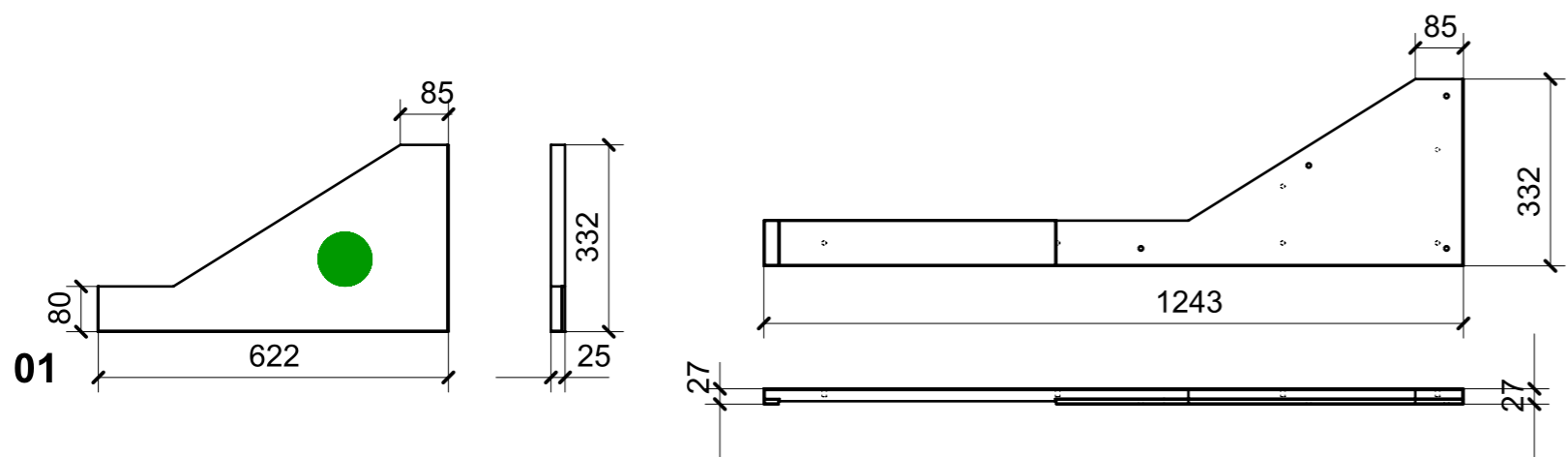

FERRAMENTA	QTY
BASE_3-NERA_HAFELE_342.22.067-BLUM_175H3130.STP	8
BUSSOLA 5MA ANKOR BORGHI	16
VITE 4MAX8 ANKOR BORGHI	16
CERNIERA 94°_PIANA-NERA_HAFELE_342.46.604-BLUM_71B9550.STP	8
MD320_GR2_R02_AR01_07	1
MAGNETE FORZA MAGNETICA1-5 10KG_HAFELE_246.87.112	6
VITE 4MAX8 ANKOR BORGHI X CERNIERA COLLO PIENO	2
BUSSOLA 5MA ANKOR BORGHI X CERNIERA COLLO PIENO	36

VERNICIATURA LASTRA/LACCATI:

● = VERNICIARE 1 LATO + FILI RASATI O BORDATI

NESSUN SIMBOLO = VERNICIARE 2 LATI + FILI RASATI O BORDATI

LOCALE	CODICE	DESCRIZIONE COMPONENTE	FINITURA	GR.
CABINA ARMATORE	MD320_R01_AT01	ARMADIO PRUA	LASTRA SCURA	2

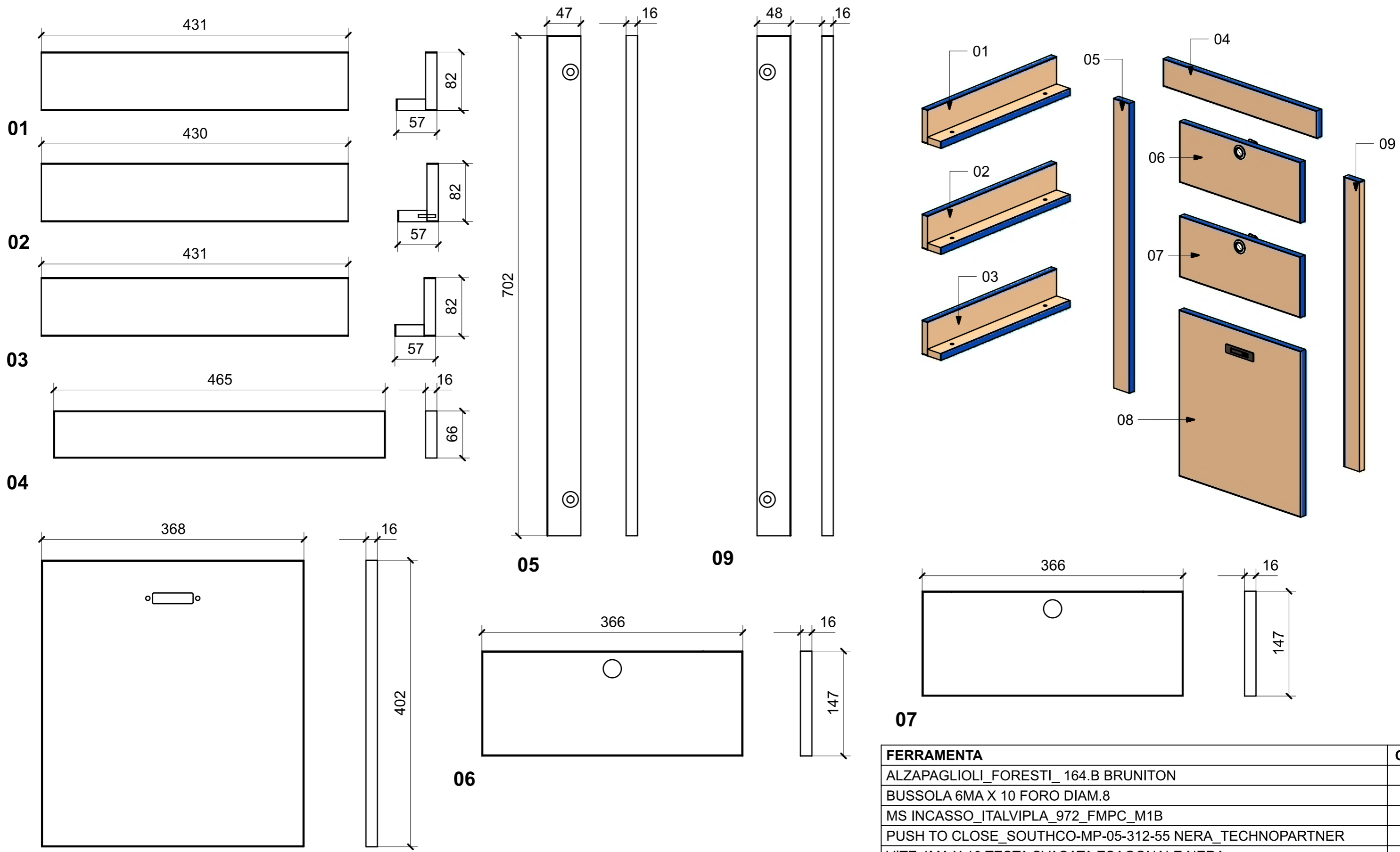

FERRAMENTA	QTY
ALZAPAGLIOLI_FORESTI_164.B BRUNITON	1
BUSSOLA 6MA X 10 FORO DIAM.8	4
MS INCASSO_ITALVIPLA_972_FMPC_M1B	4
PUSH TO CLOSE_SOUTHCO-MP-05-312-55 NERA_TECHNOPARTNER	2
VITE 4MA X 10 TESTA SVASATA ESAGONALE NERA	2

VERNICIATURA LASTRA/LACCATI:
 = VERNICIARE 1 LATO + FILI RASATI O BORDATI NESSUN SIMBOLO = VERNICIARE 2 LATI + FILI RASATI O BORDATI

08

04

03

02

01

05

09

06

07

LOCALE	CODICE	DESCRIZIONE COMPONENTE	FINITURA	GR.
CABINA ARMATORE	MD321_R01_AAT01	FACCIATA ARMADIO PRUA VAR.1	LASTRA SCURA	2

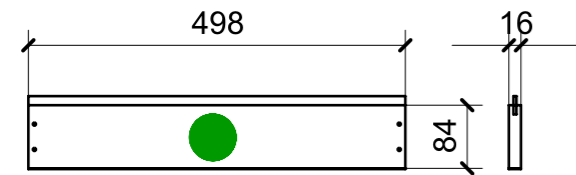

01

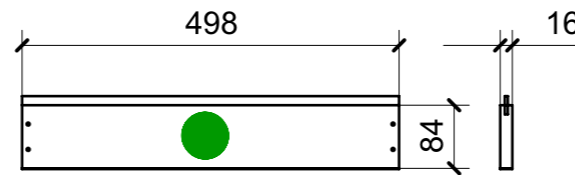

03

ELEMENTI DA MONTARE
CON LASTRA CHIARA
in MF_AAT01
e spedire con unico imballo

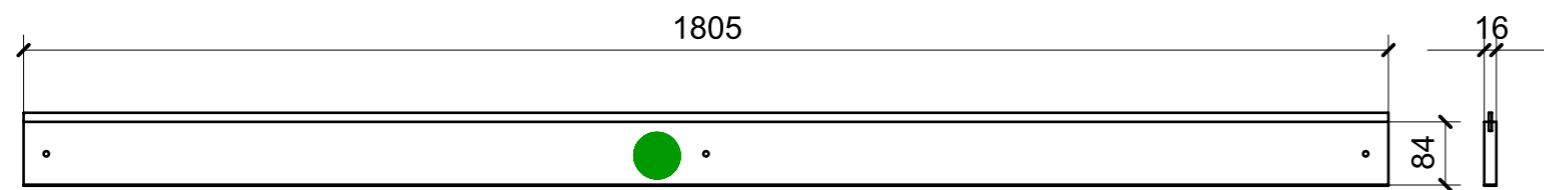

02

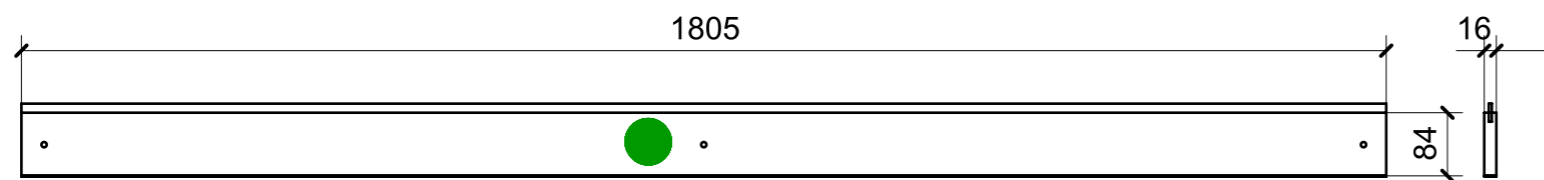

04

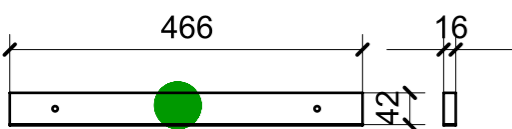

05

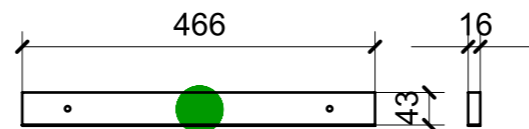

06

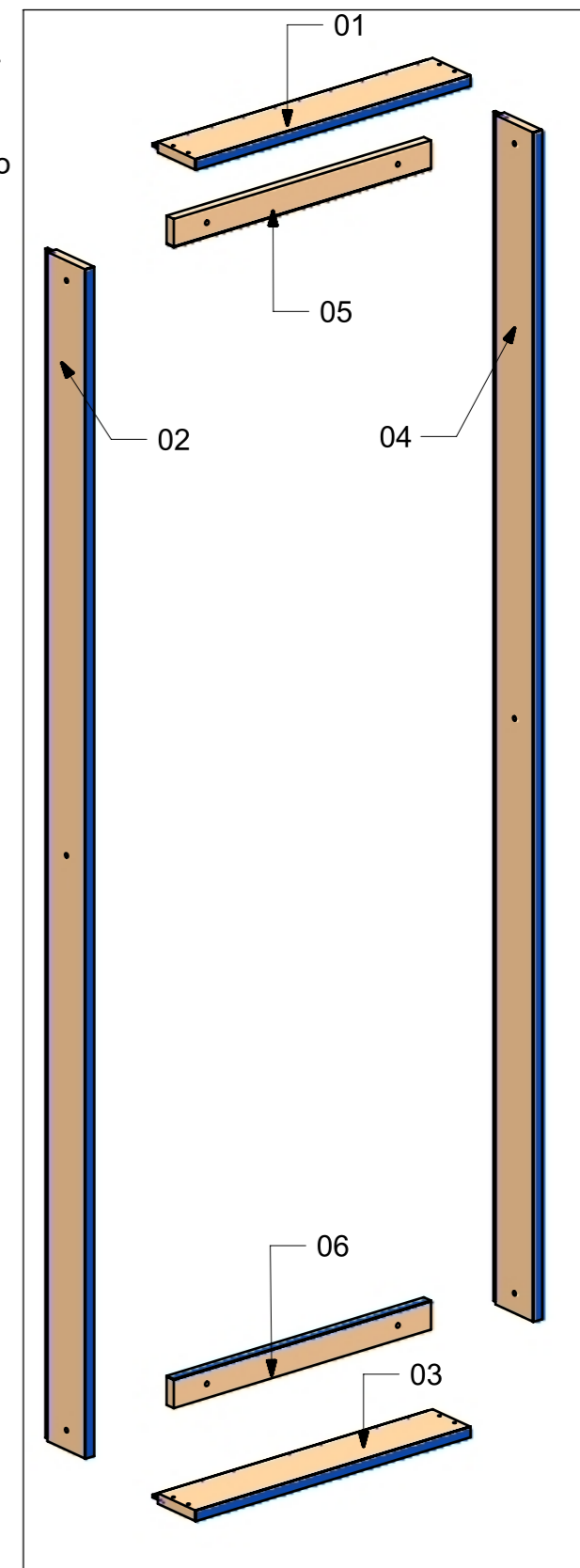

VERNICIATURA LASTRA/LACCATI:

● = VERNICIARE 1 LATO + FILI RASATI O BORDATI

NESSUN SIMBOLO = VERNICIARE 2 LATI + FILI RASATI O BORDATI

LOCALE	CODICE	DESCRIZIONE COMPONENTE	FINITURA	GR.
CABINA ARMATORE	MD321_R02_AAT01	FACCIATA ARMADIO PRUA VAR.1	LASTRA CHIARA	2

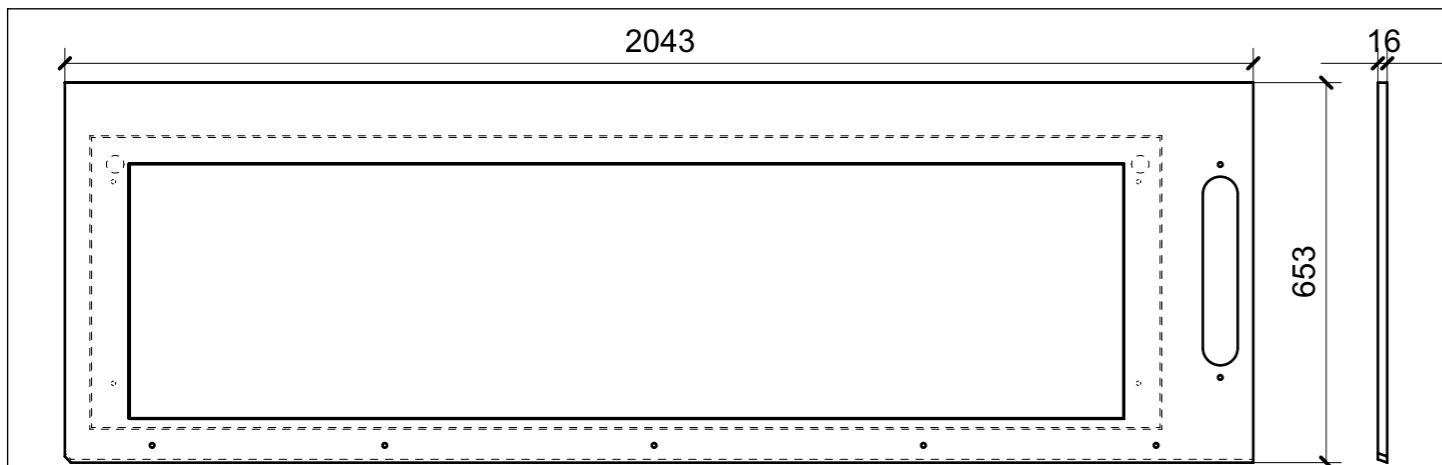

01

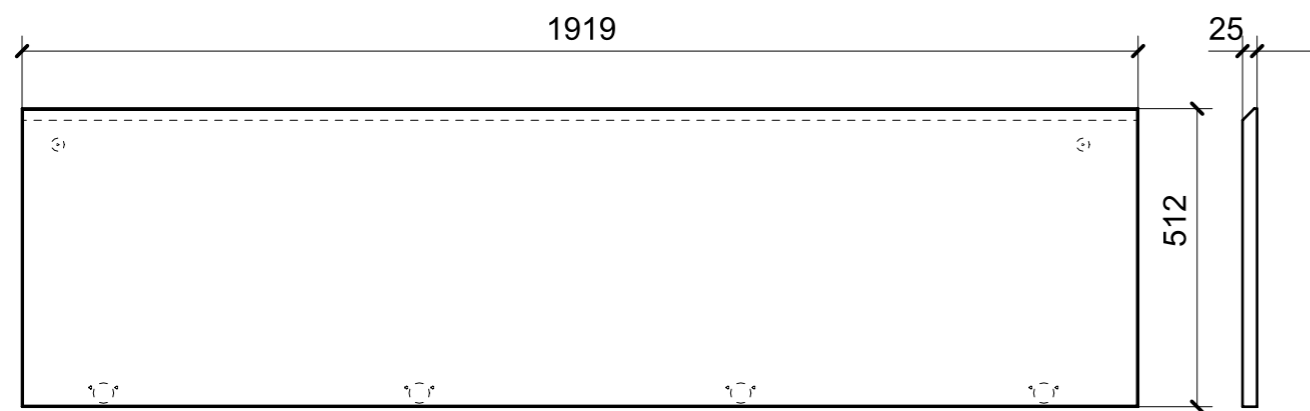

03

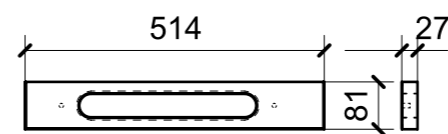

02

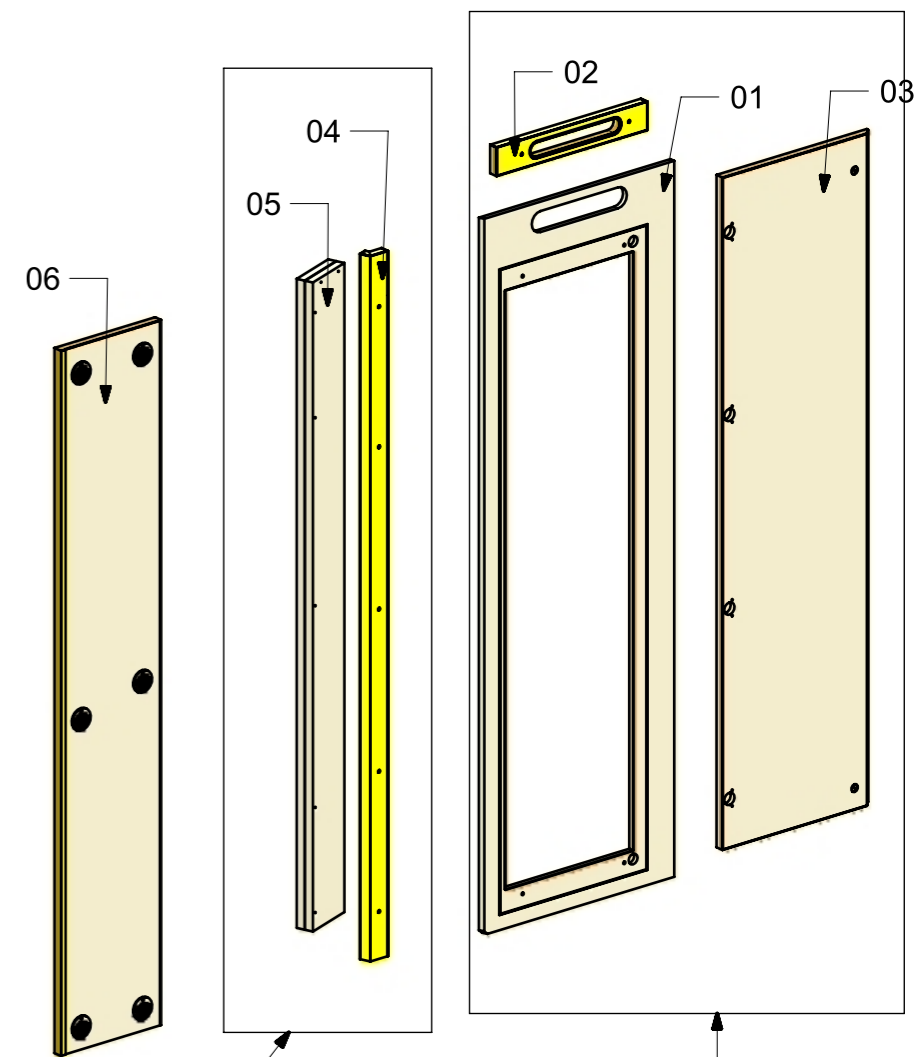

ELEMENTI DA MONTARE
in MG_AAT01
e spedire con unico imballo

ELEMENTI DA MONTARE
CON LASTRA SCURA
in MF_AAT01
e spedire con unico imballo

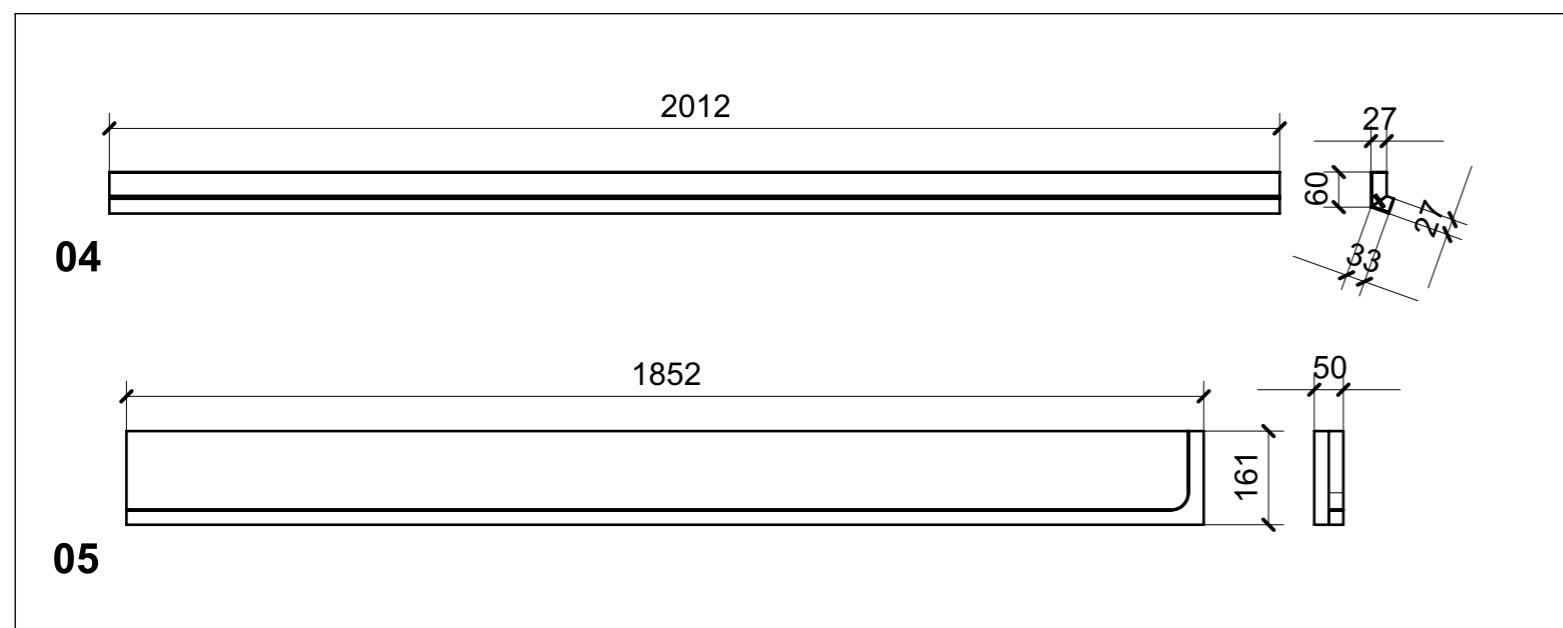

04

05

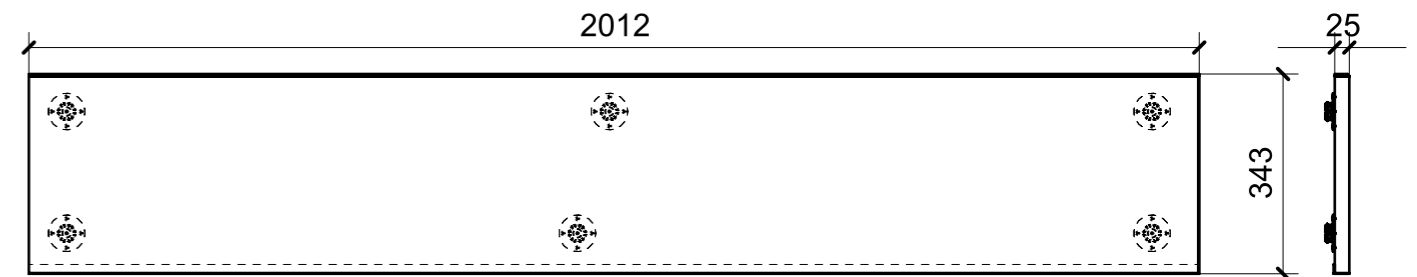

06

VERNICIATURA LASTRA/LACCATI:

● = VERNICIARE 1 LATO + FILI RASATI O BORDATI

NESSUN SIMBOLO = VERNICIARE 2 LATI + FILI RASATI O BORDATI

LOCALE	CODICE	DESCRIZIONE COMPONENTE	FINITURA	GR.
CABINA ARMATORE	MD320_R01_AU01	FACCIATA ARMADIO PRUA VAR1-VAR2	LASTRA SCURA	2

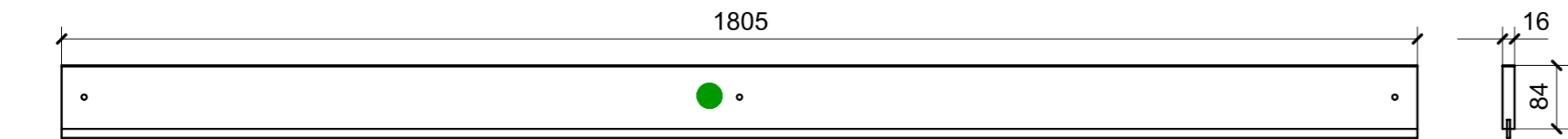

01

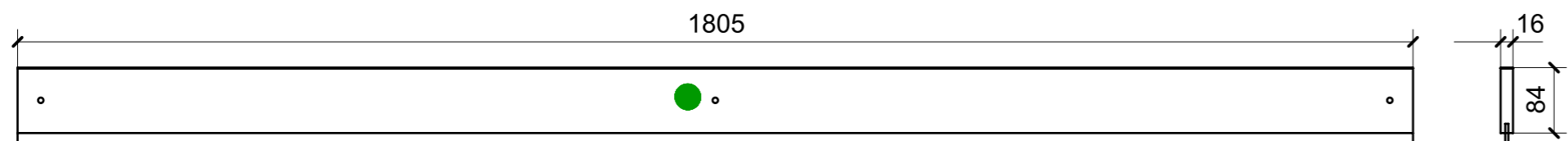

03

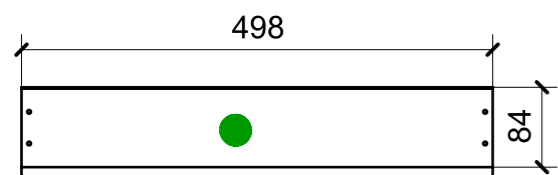

02

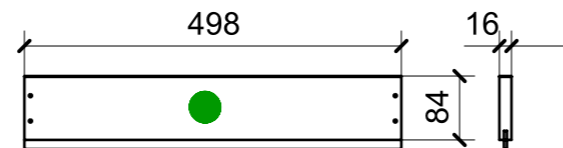

04

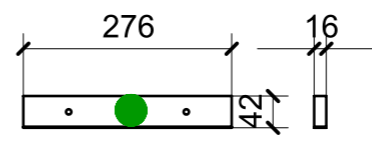

11

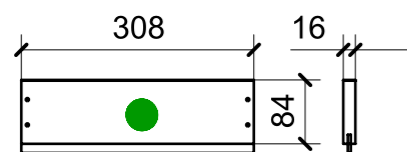

08

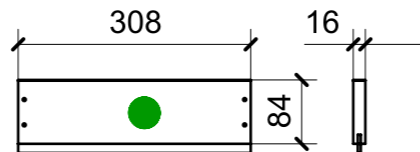

10

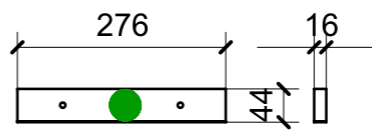

12

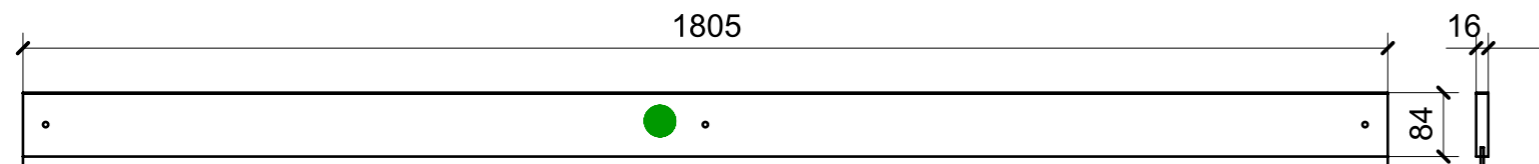

07

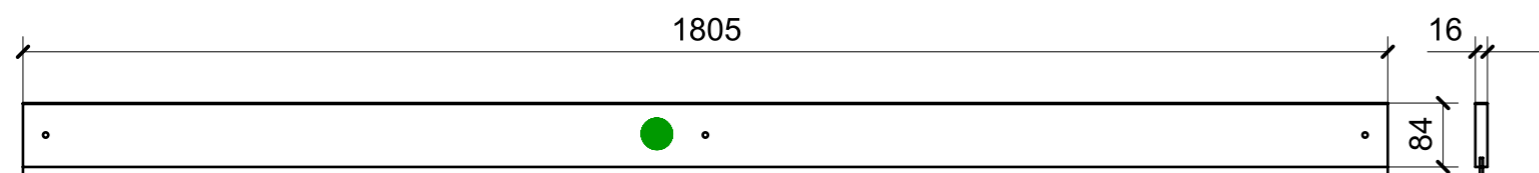

09

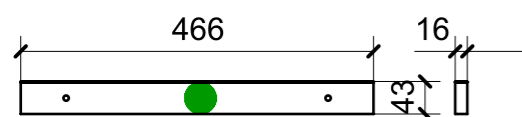

05

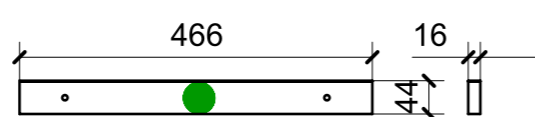

06

ELEMENTI DA MONTARE

in MF_AU01
e spedire con unico imballo
FERRAMENTA: VEDI MONTATO FINITO

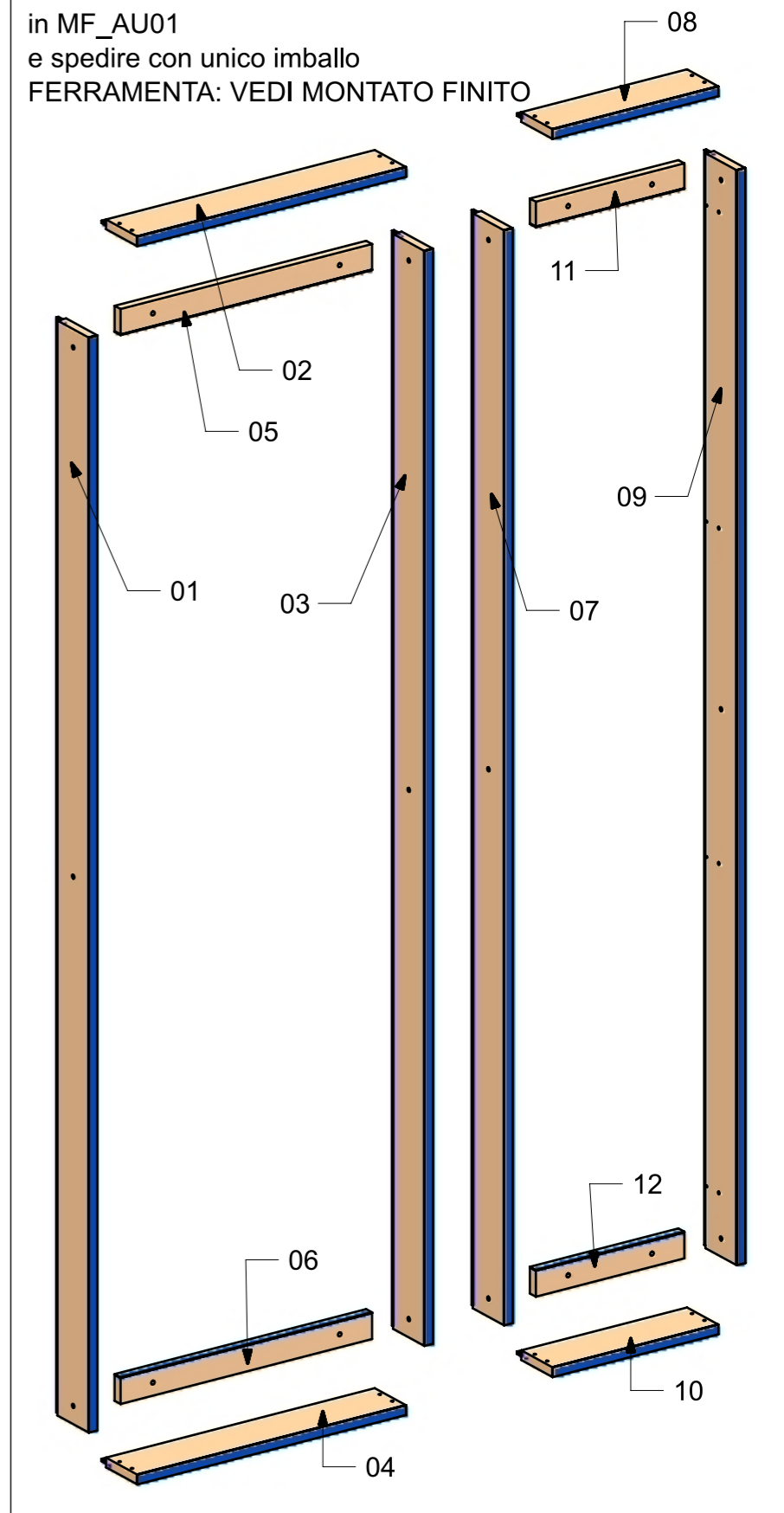

VERNICIATURA LASTRA/LACCATI:

● = VERNICIARE 1 LATO + FILI RASATI O BORDATI

NESSUN SIMBOLO = VERNICIARE 2 LATI + FILI RASATI O BORDATI

LOCALE	CODICE	DESCRIZIONE COMPONENTE	FINITURA	GR.
CABINA ARMATORE	MD320_R02_AU01	FACCIATA ARMADIO PRUA VAR1-VAR2	LASTRA SCURA	2

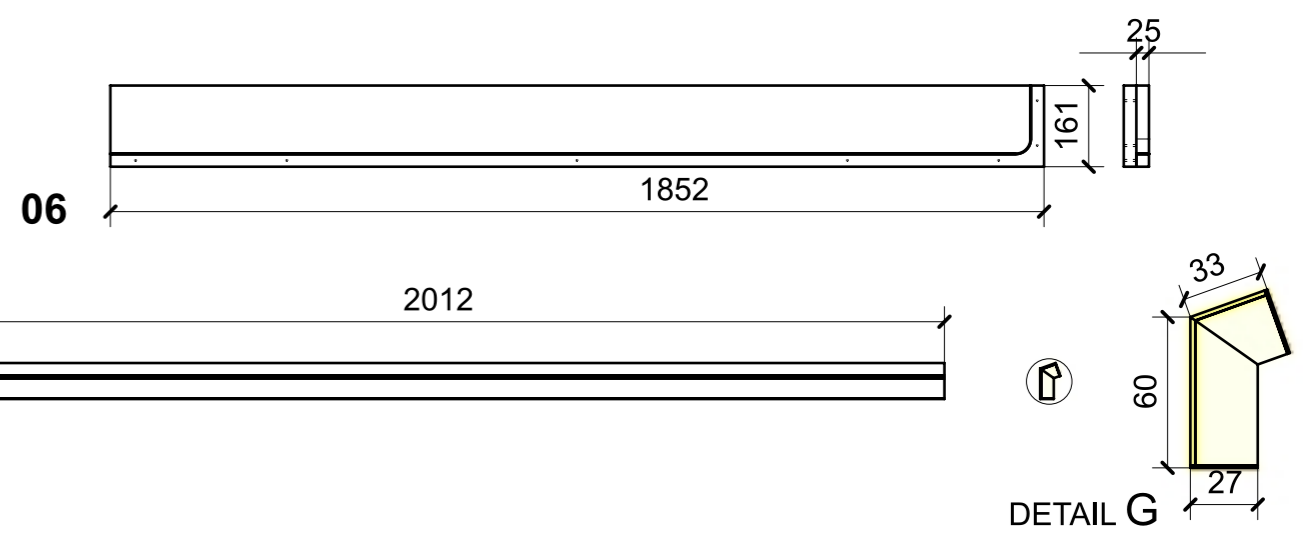
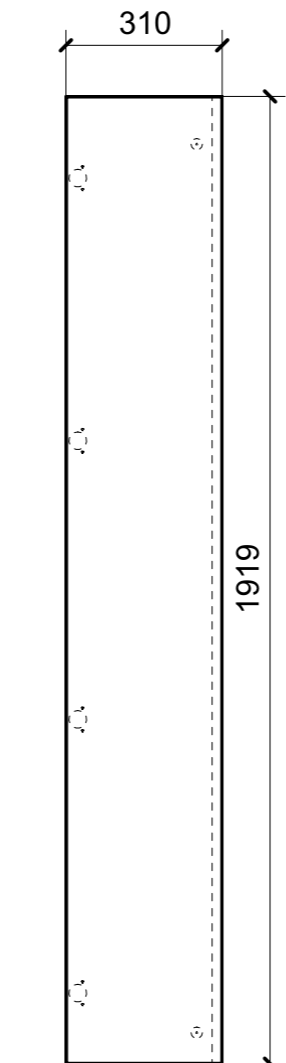
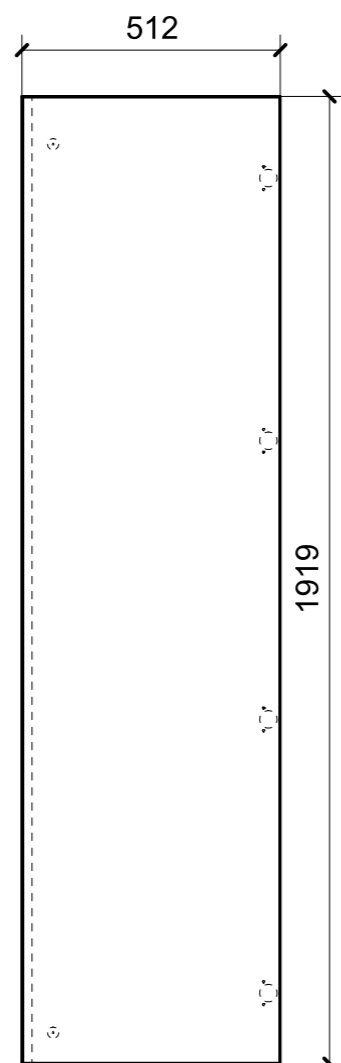
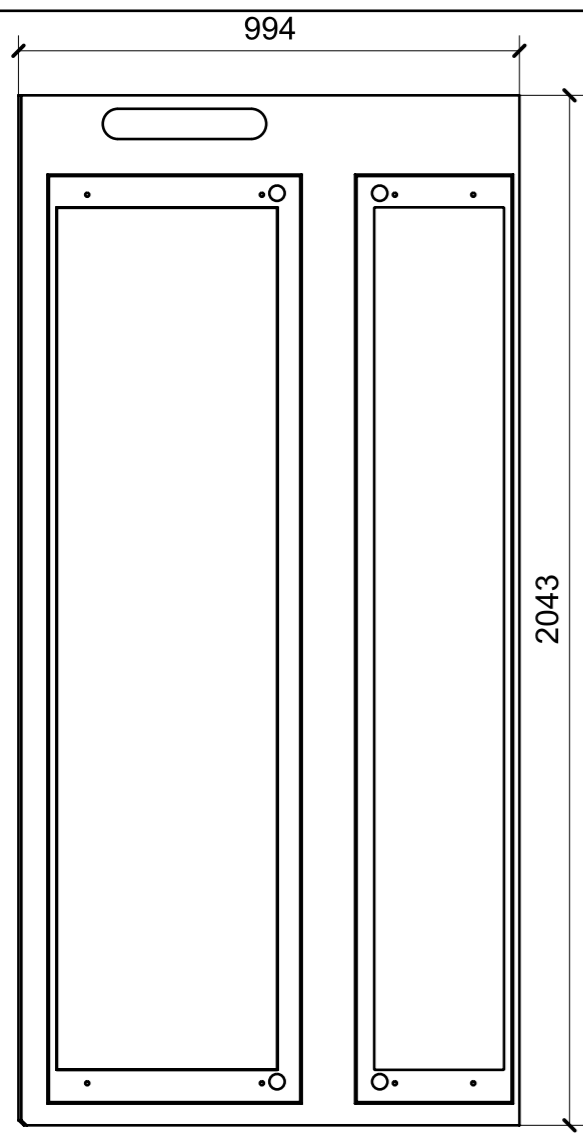

01

02

03

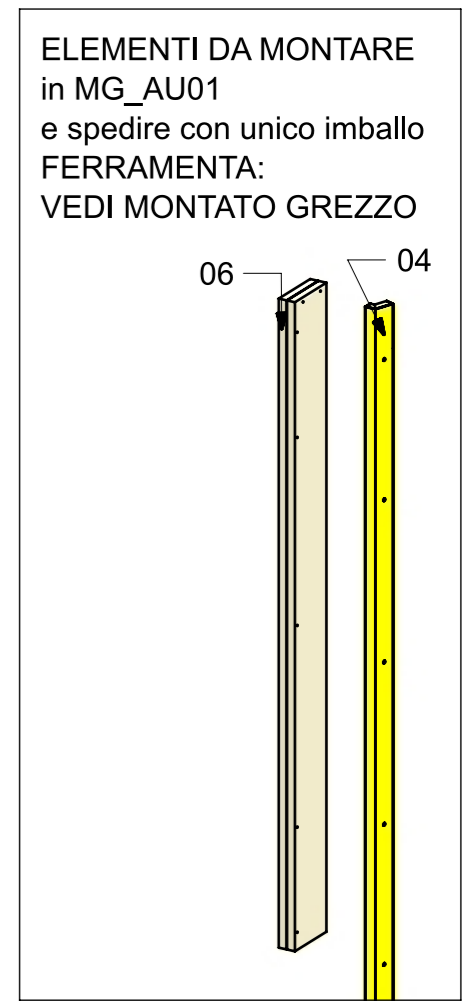
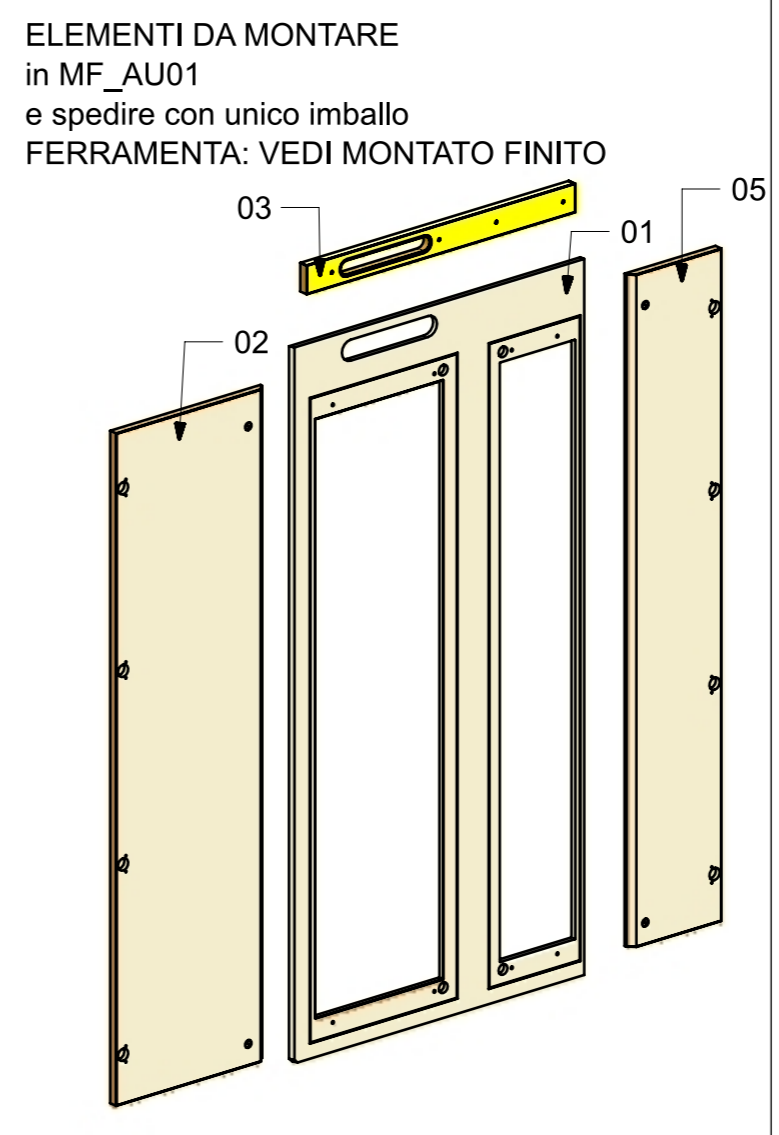
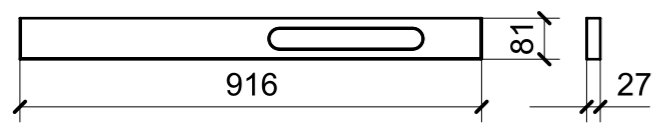

VERNICIATURA LASTRA/LACCATI:

● = VERNICIARE 1 LATO + FILI RASATI O BORDATI

NESSUN SIMBOLO = VERNICIARE 2 LATI + FILI RASATI O BORDATI

LOCALE	CODICE	DESCRIZIONE COMPONENTE	FINITURA	GR.
CABINA ARMATORE	MD320_R01_AX01	RIV. PARETE TV INGRESSO BAGNO VAR.1-VAR.2	LASTRA SCURA	2

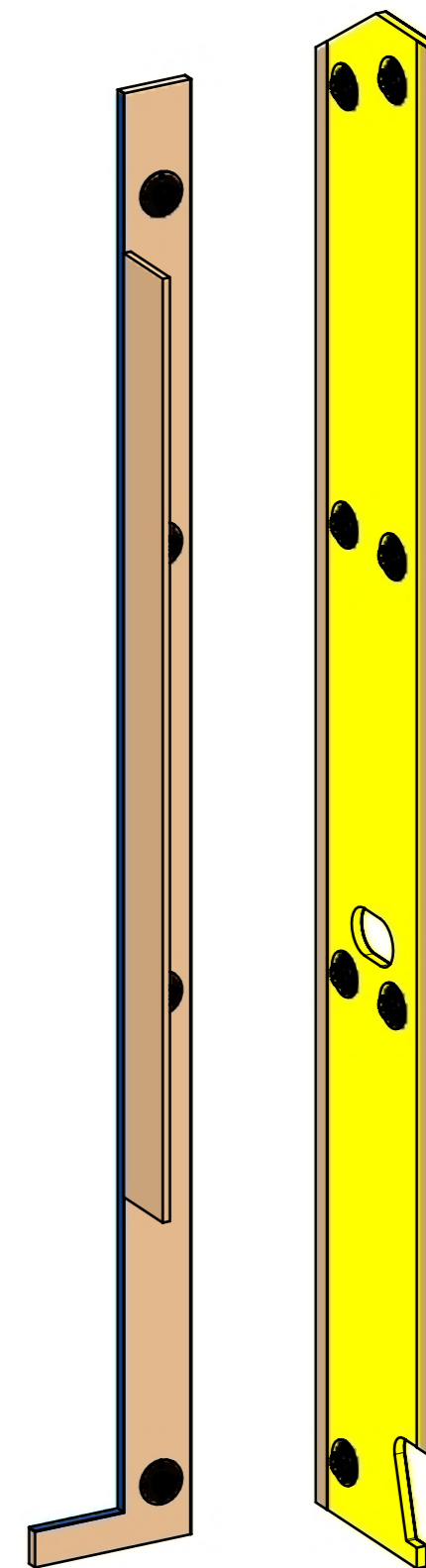
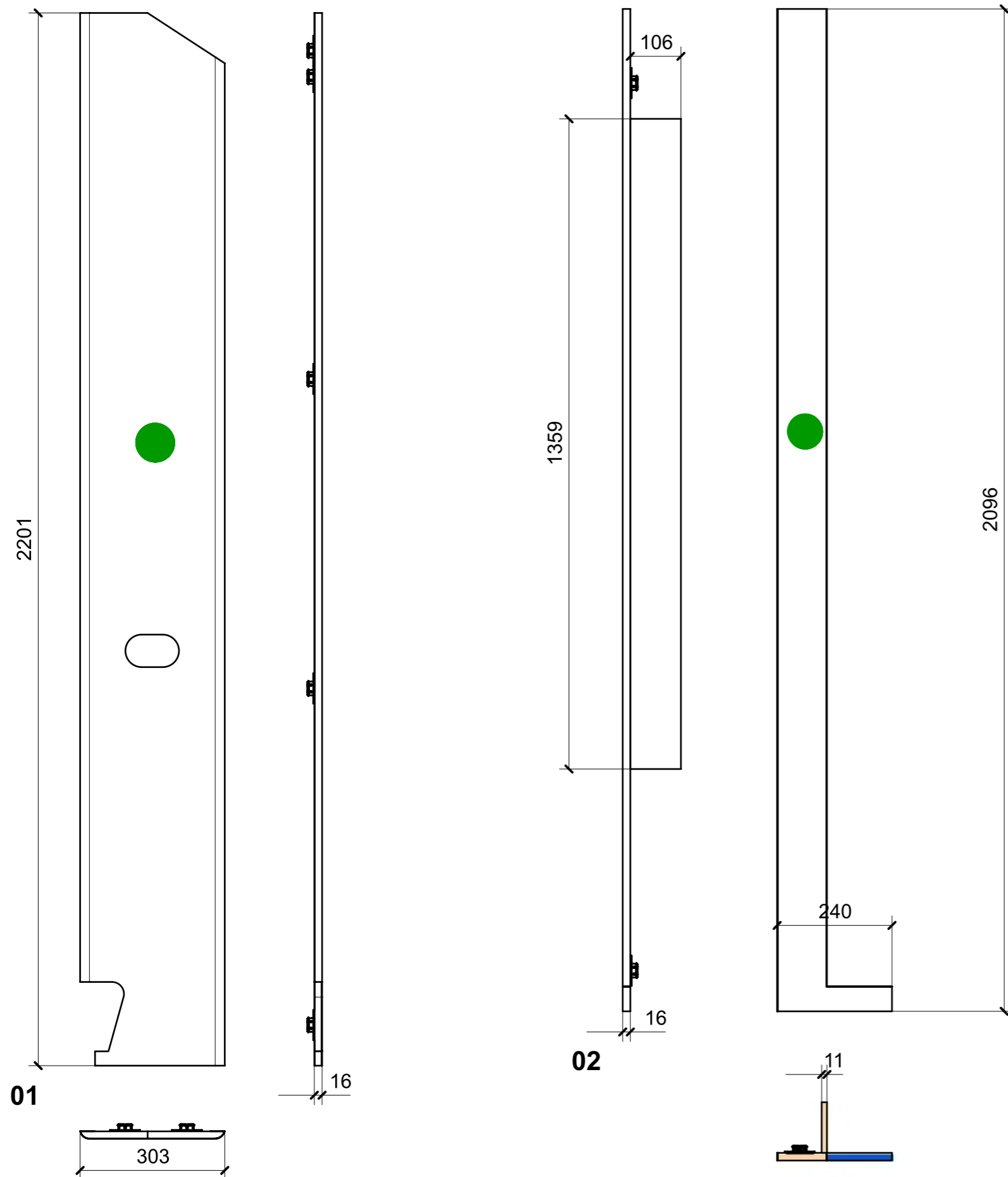

FERRAMENTA	QTY
FITLOCK M_MASCHERPA_3MM_6020202101	11

VERNICIATURA LASTRA/LACCATI:

● = VERNICIARE 1 LATO + FILI RASATI O BORDATI

NESSUN SIMBOLO = VERNICIARE 2 LATI + FILI RASATI O BORDATI

LOCALE	CODICE	DESCRIZIONE COMPONENTE	FINITURA	GR.
CABINA ARMATORE	MD320_R01_AAU01	FACCIATA ARMADIO PRUA VAR3-VAR4	LASTRA SCURA	2

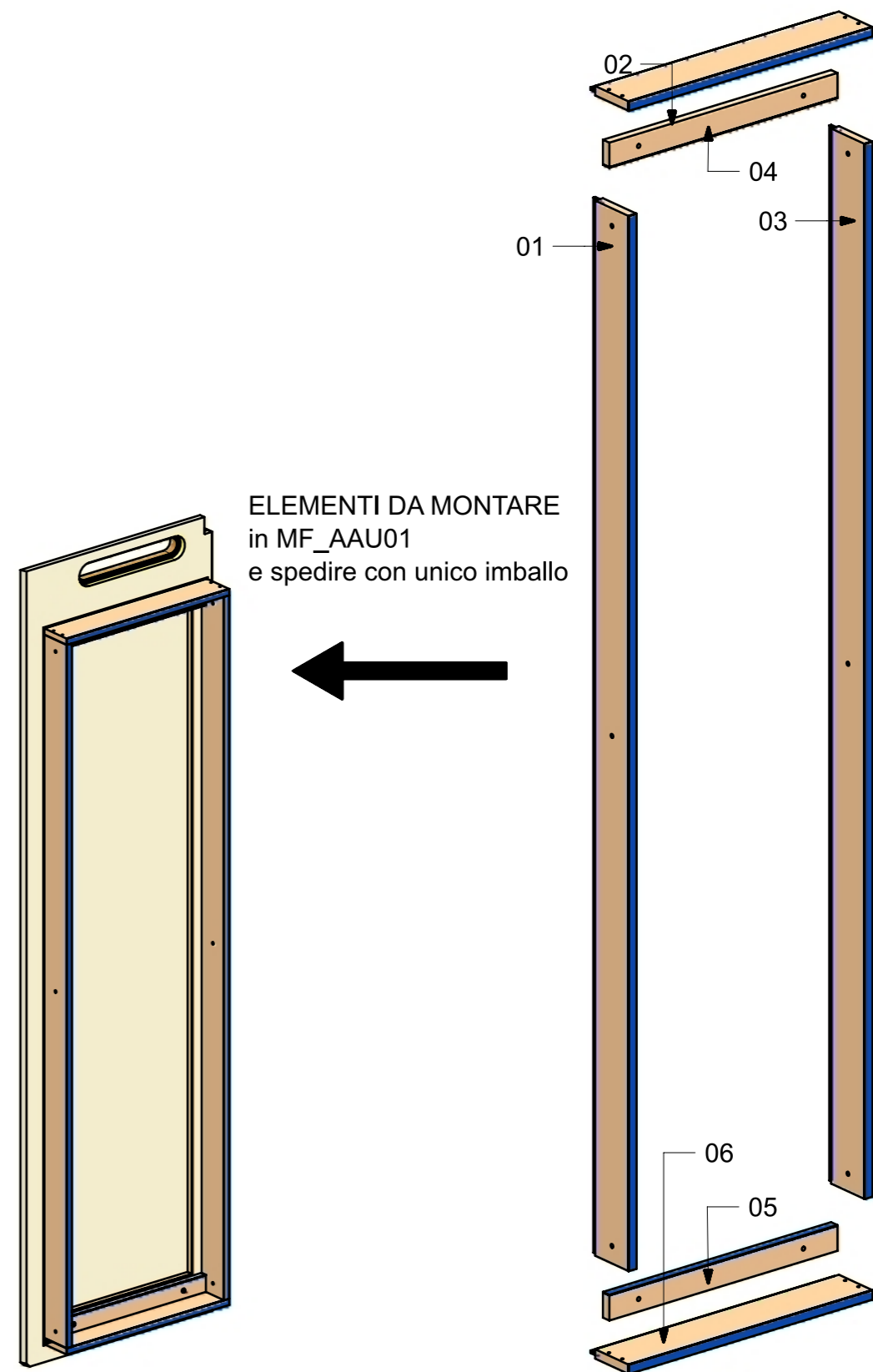
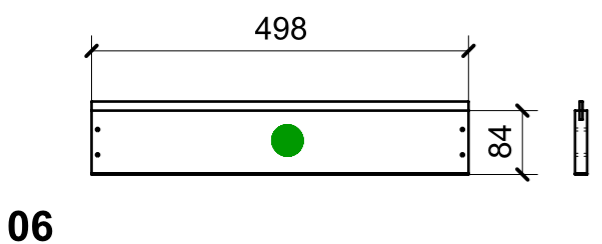
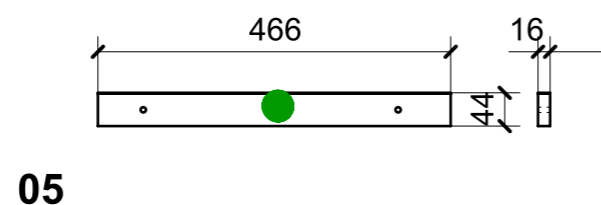
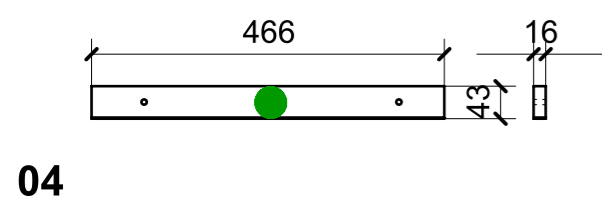
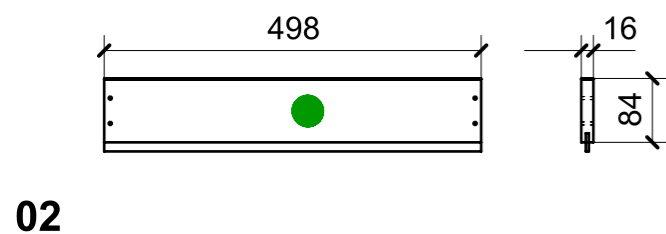
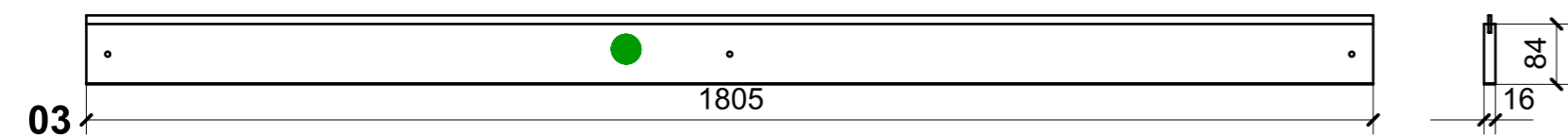
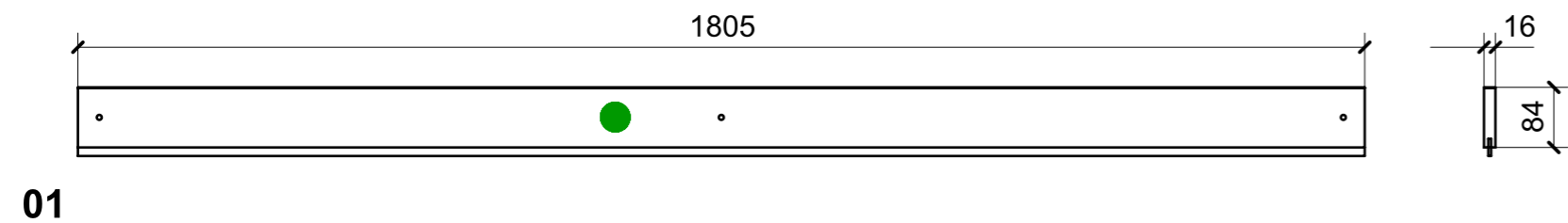

ELEMENTI DA MONTARE
in MF_AAU01
e spedire con unico imballo

VERNICIATURA LASTRA/LACCATI:

● = VERNICIARE 1 LATO + FILI RASATI O BORDATI

NESSUN SIMBOLO = VERNICIARE 2 LATI + FILI RASATI O BORDATI

LOCALE	CODICE	DESCRIZIONE COMPONENTE	FINITURA	GR.
CABINA ARMATORE	MD320_R02_AAU01	FACCIATA ARMADIO PRUA VAR3-VAR4	LASTRA CHIARA	2

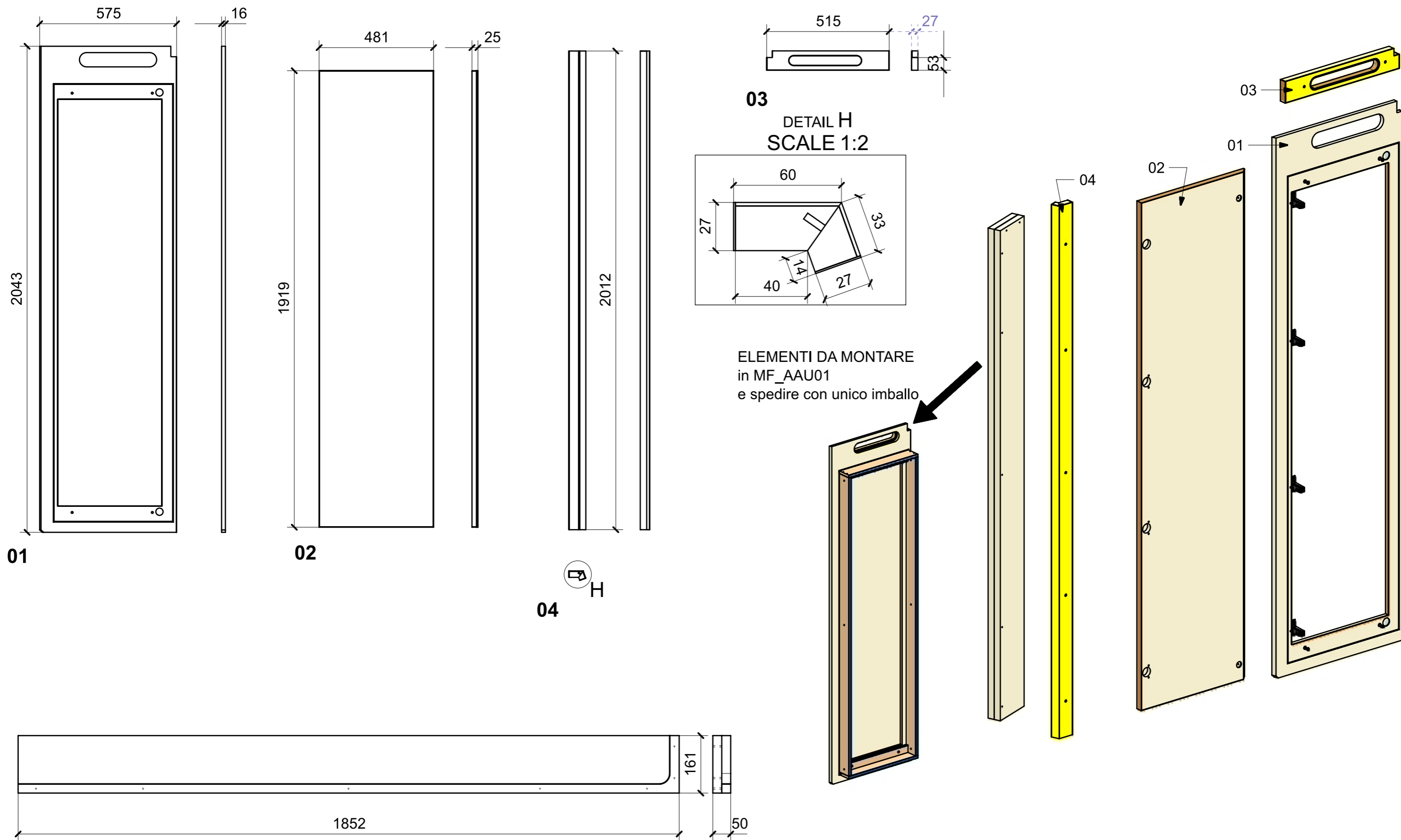

VERNICIATURA LASTRA/LACCATI:
 ● = VERNICIARE 1 LATO + FILI RASATI O BORDATI

NESSUN SIMBOLO = VERNICIARE 2 LATI + FILI RASATI O BORDATI

LOCALE	CODICE	DESCRIZIONE COMPONENTE	FINITURA	GR.
CABINA ARMATORE	MD320_R01_AAX01	RIV. PARETE TV INGRESSO BAGNO VAR.3-4	LASTRA SCURA	2

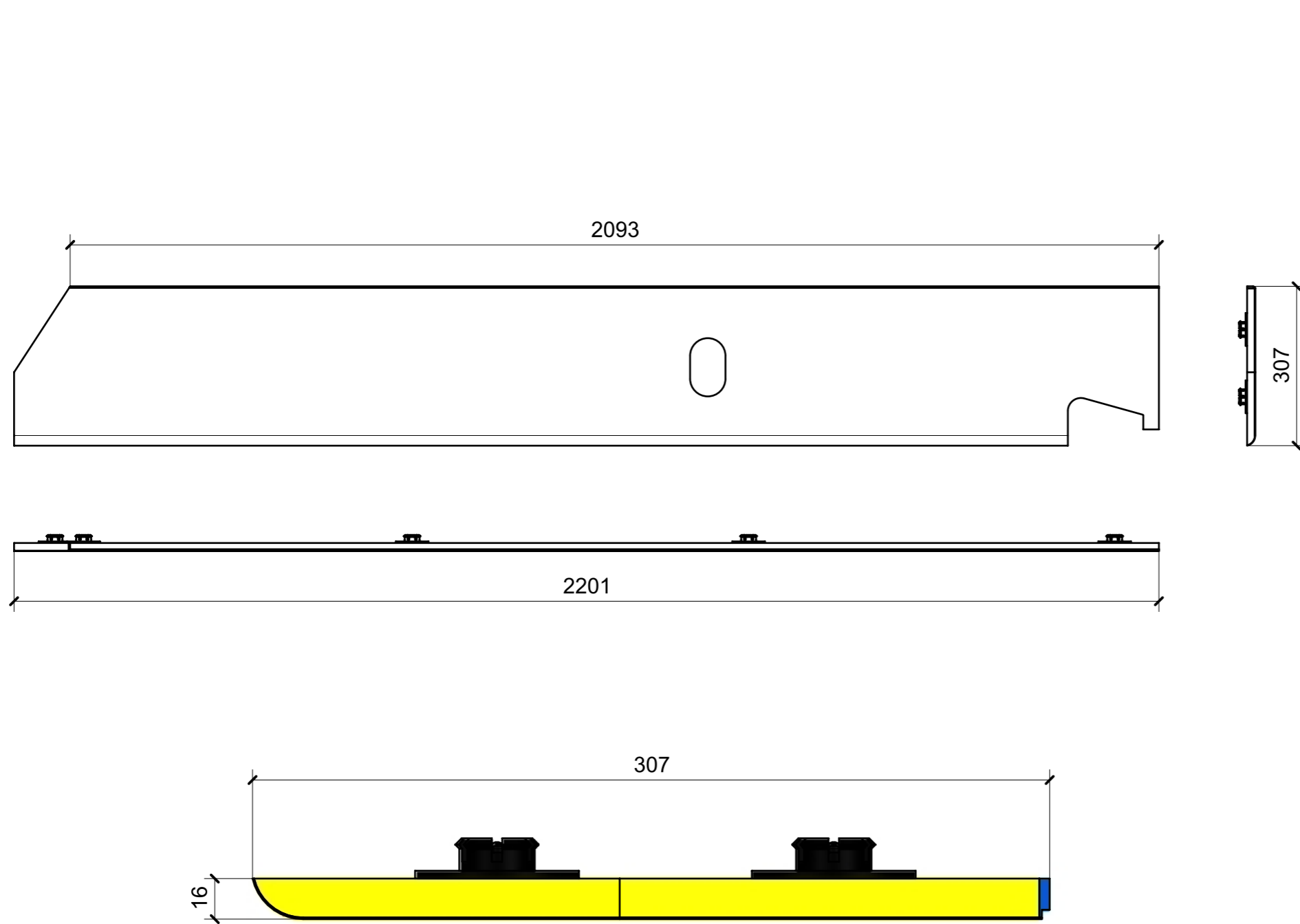

FRONTE

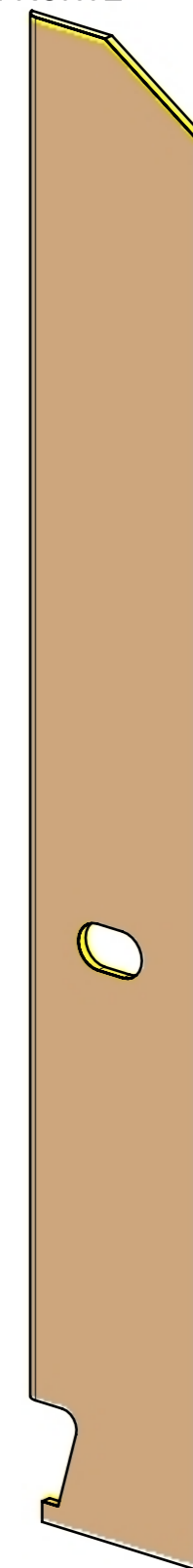

RETRO

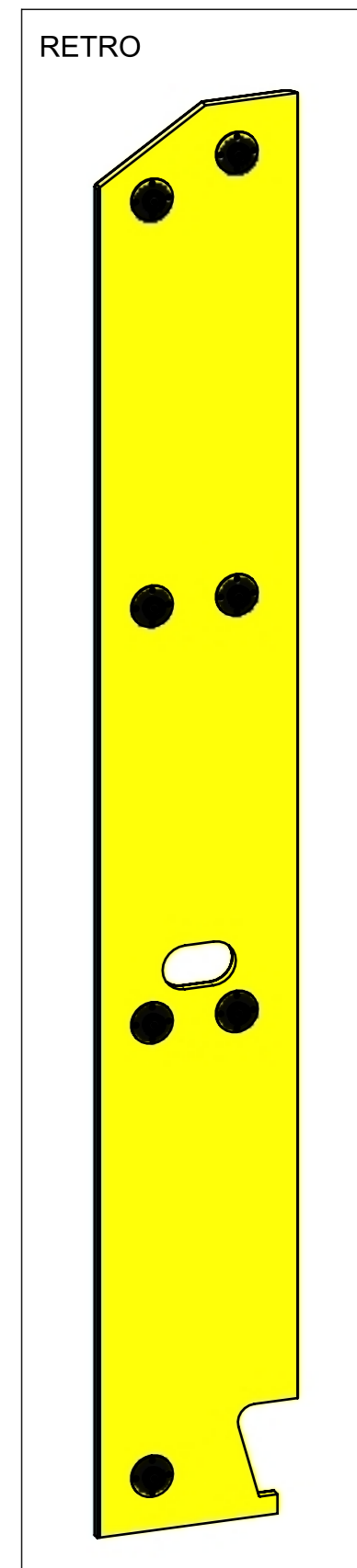

FERRAMENTA	QTY
FITLOCK M_MASCHERPA_3MM_6020202101	7

VERNICIATURA LASTRA/LACCATI:

● = VERNICIARE 1 LATO + FILI RASATI O BORDATI

NESSUN SIMBOLO = VERNICIARE 2 LATI + FILI RASATI O BORDATI

LOCALE	CODICE	DESCRIZIONE COMPONENTE	FINITURA	GR.
CABINA ARMATORE	MD320_R02_AAX01	RIV. PARETE TV INGRESSO BAGNO VAR.3-4	LASTRA CHIARA	PTP

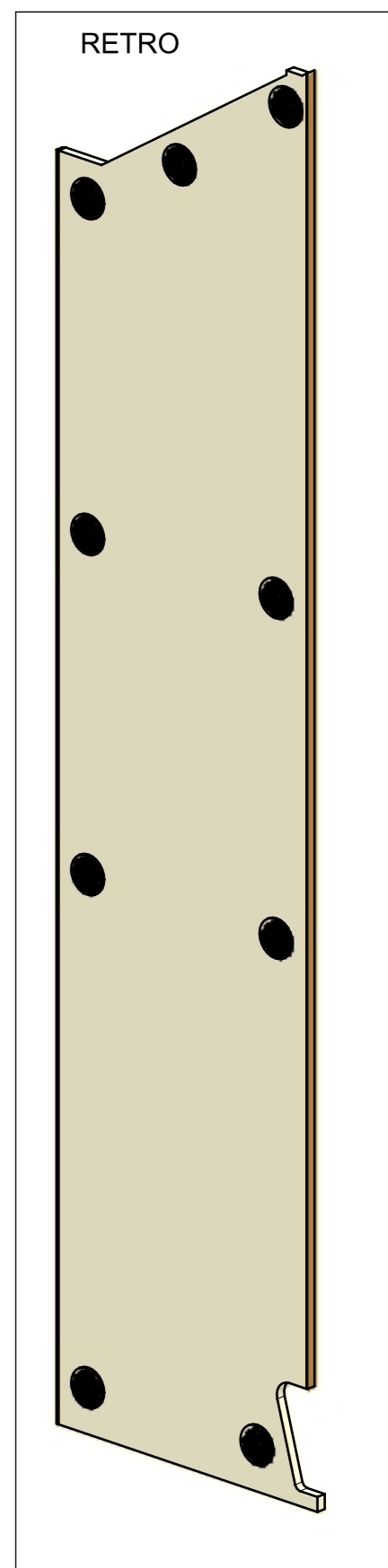
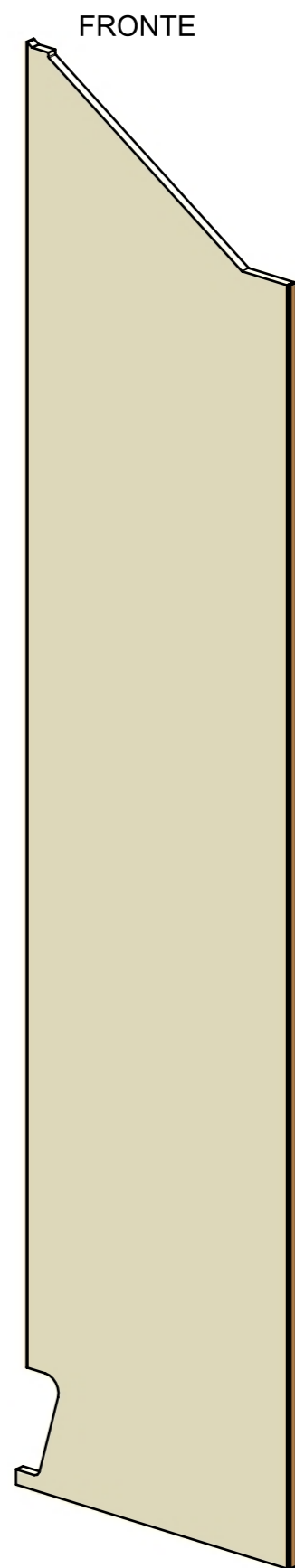
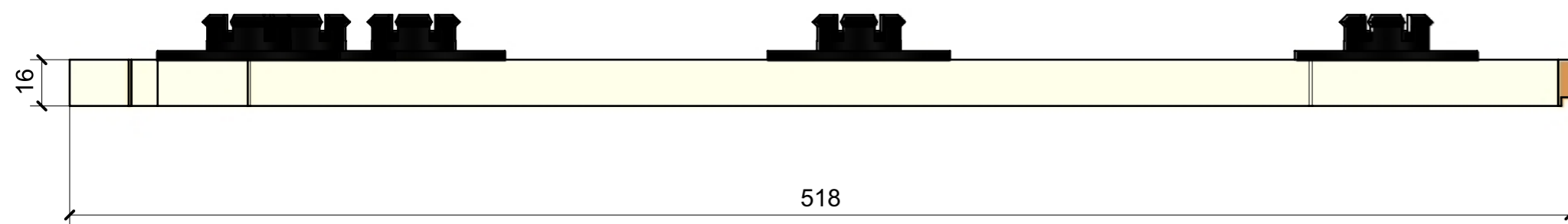
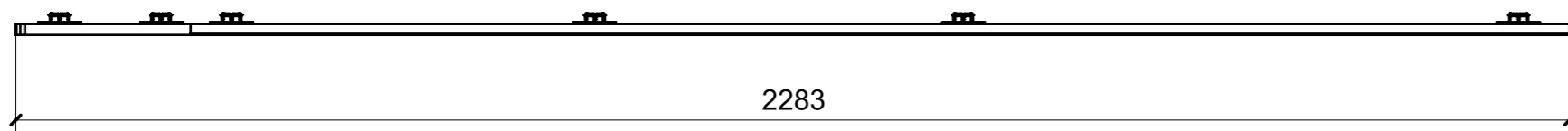
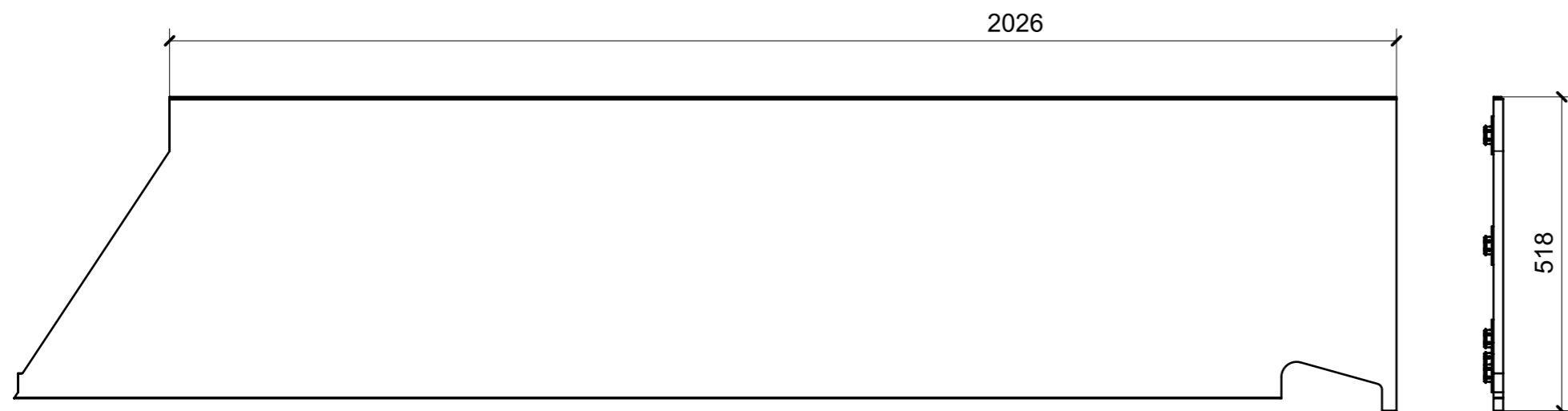

FERRAMENTA	QTY
FITLOCK M_MASCHERPA_3MM_6020202101	9

VERNICIATURA LASTRA/LACCATI:
 ● = FILI RASATI ● = VERNICIARE 1 LATO + FILI RASATI O BORDATI NESSUN SIMBOLO = VERNICIARE 2 LATI + FILI RASATI O BORDATI