

LOCALE	CODICE	DESCRIZIONE COMPONENTE	FINITURA	Q.TA
LOBBY	MD298_R01_CB01	RIV. PARATIA DIVISORIA OSPITI	LASTRA CHIARA	1

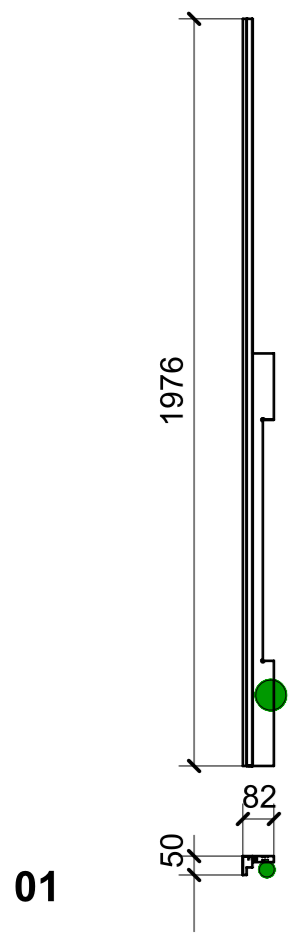

01

FERRAMENTA	QTY
BUSSOLA 5MA X 10 FORO DIAM.8	2

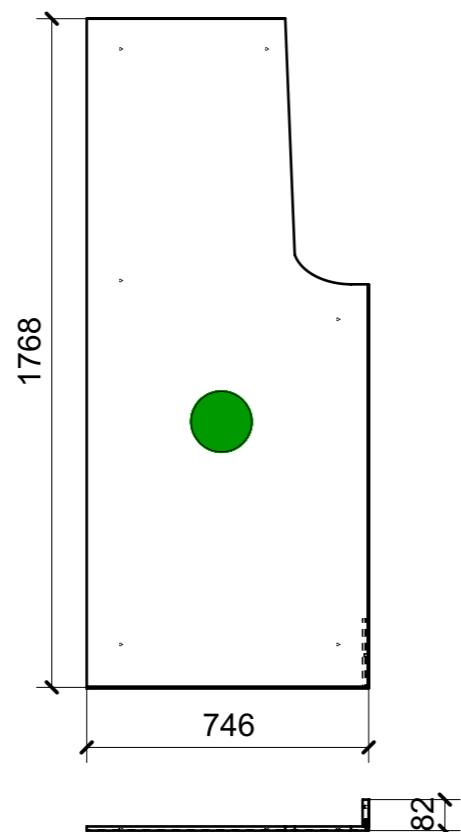

04

FERRAMENTA	QTY
BUSSOLA 5MA X 10 FORO DIAM.8	1

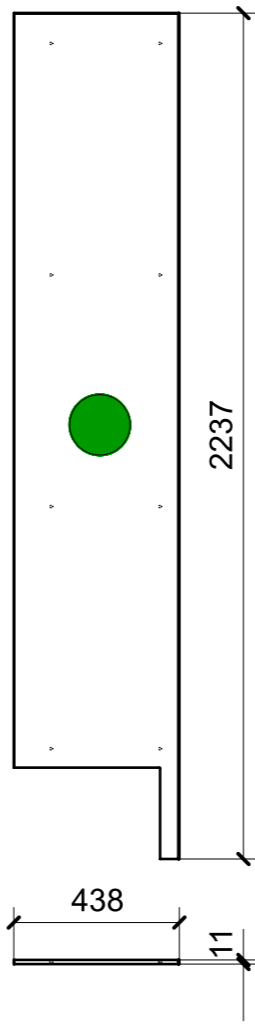

06

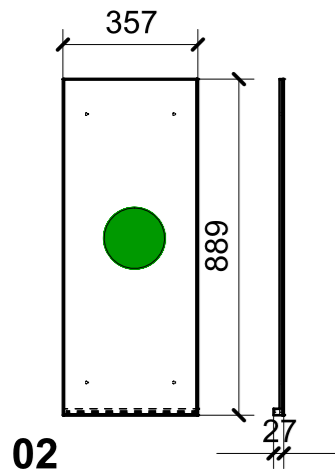
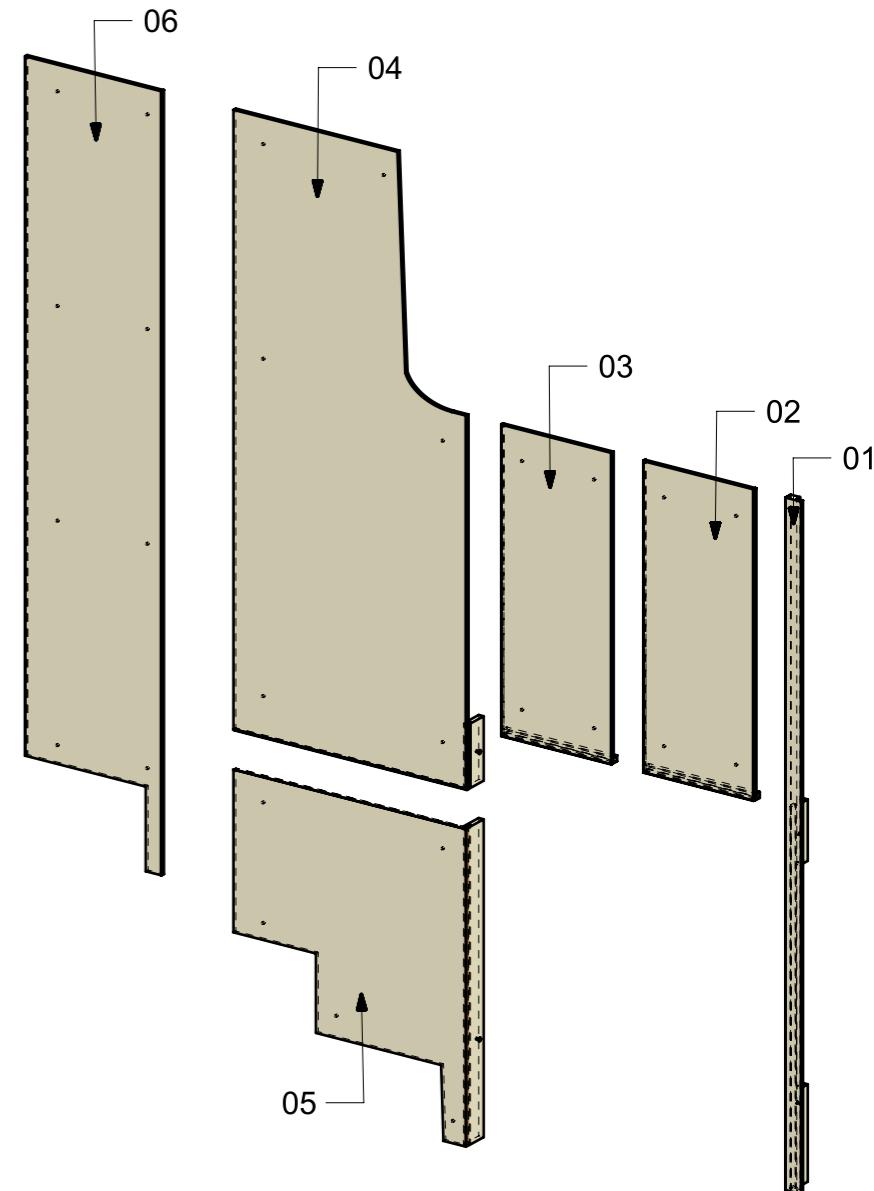

02

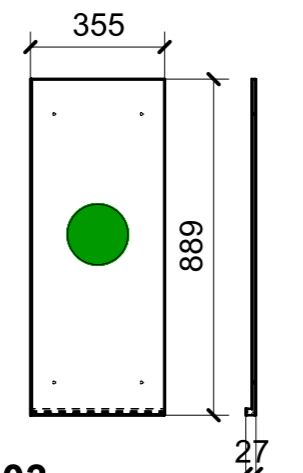

03

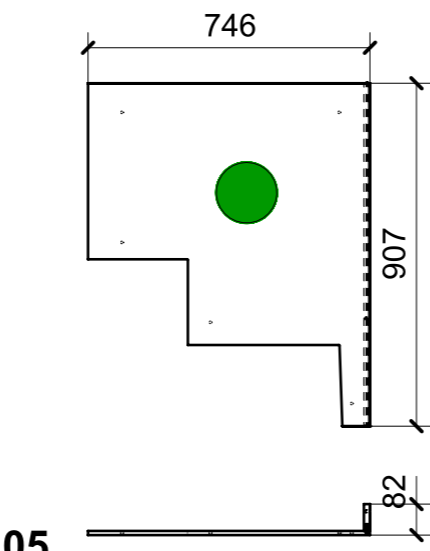

05

FERRAMENTA	QTY
BUSSOLA 5MA X 10 FORO DIAM.8	1

VERNICIATURA LASTRA/LACCATI:
 ● = VERNICIARE 1 LATO + FILI RASATI O BORDATI
 NESSUN SIMBOLO = VERNICIARE 2 LATI + FILI RASATI O BORDATI

LOCALE	CODICE	DESCRIZIONE COMPONENTE	FINITURA	Q.TA
LOBBY	MD298_L01_CG01	MONTANTE VERTICALE MOBILE SOTTOSCALA	LACCATO BIANCO PERLA RAL 1013	1

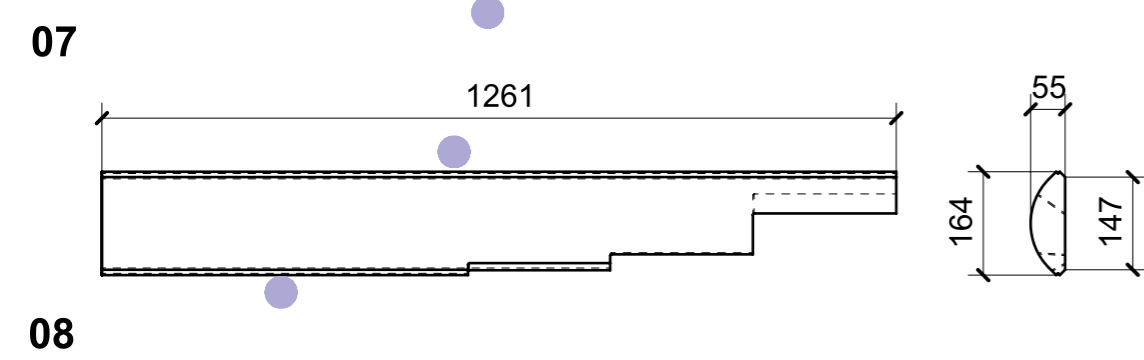
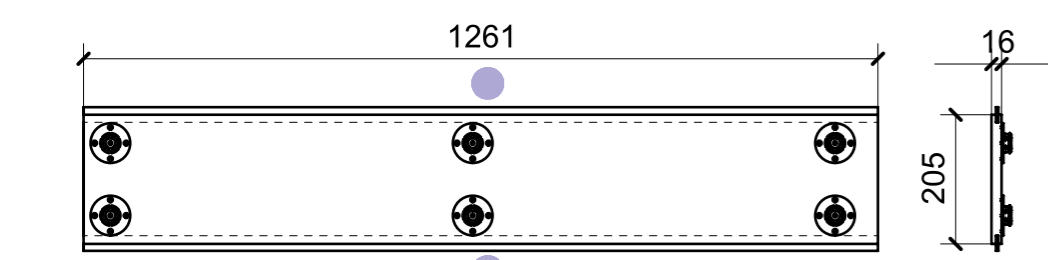
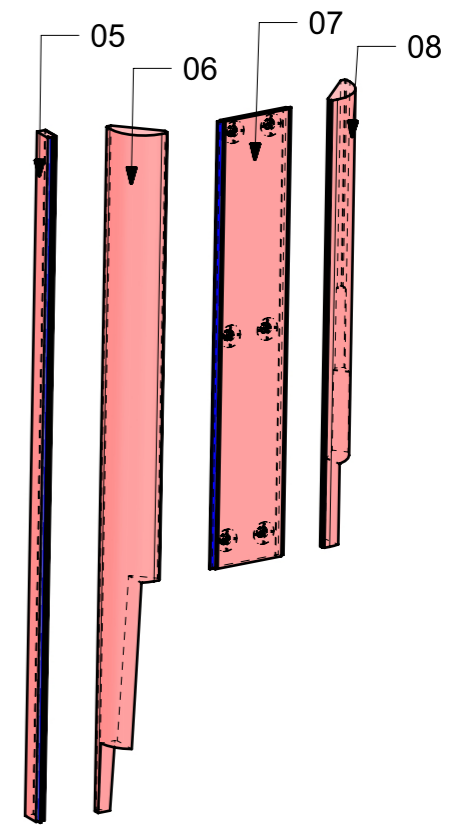
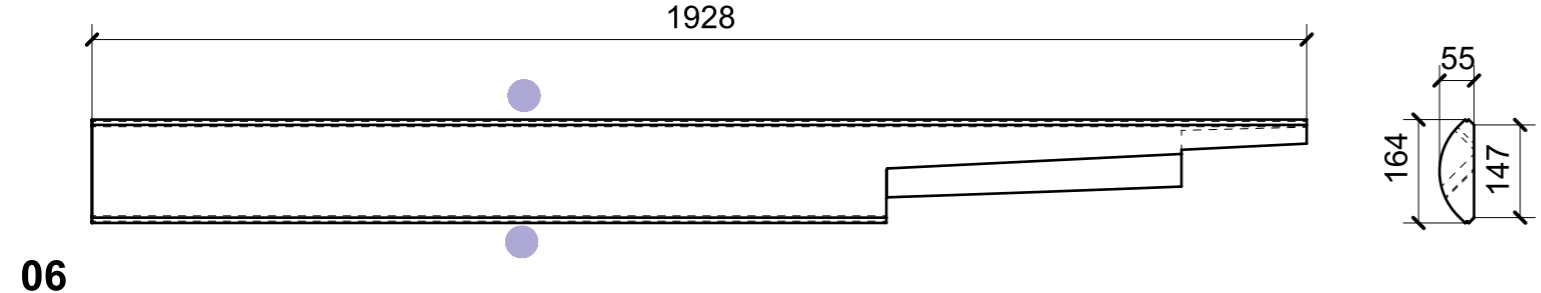
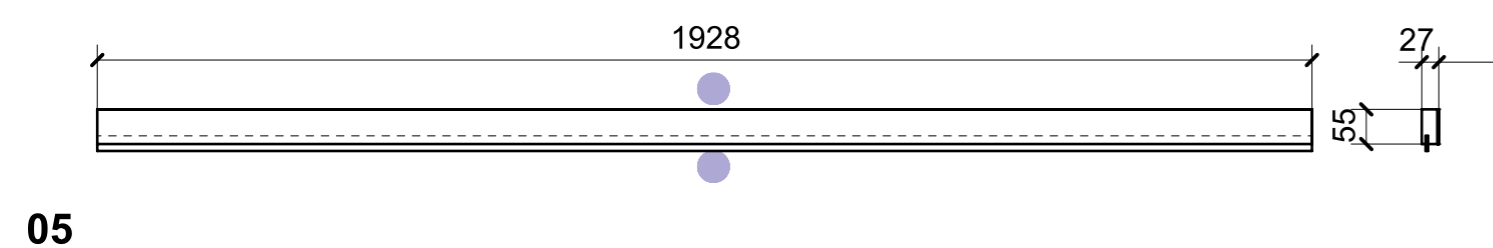
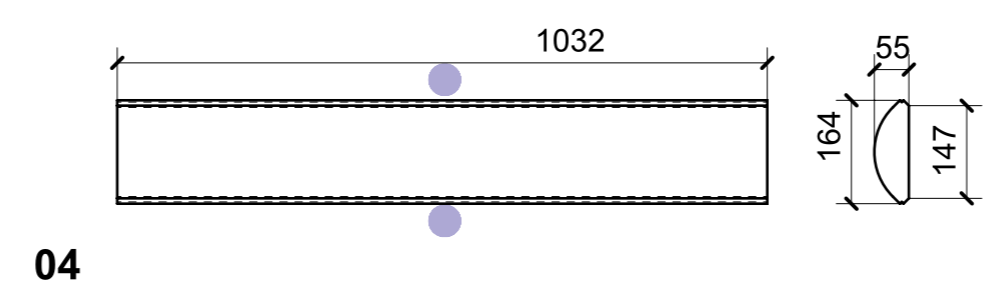
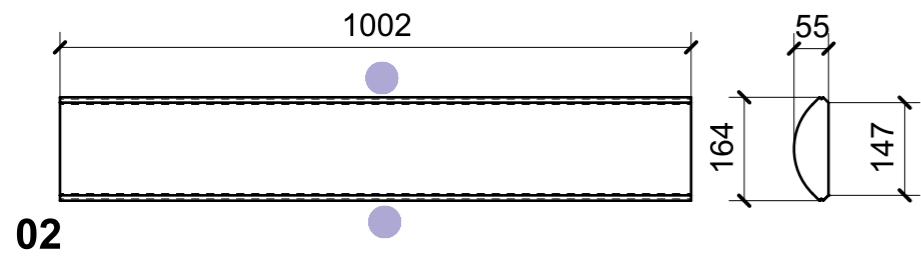
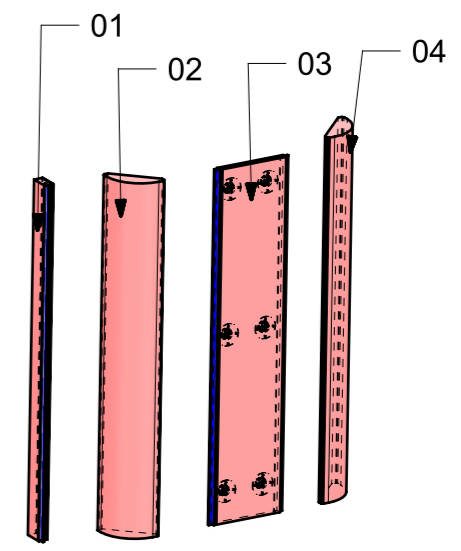
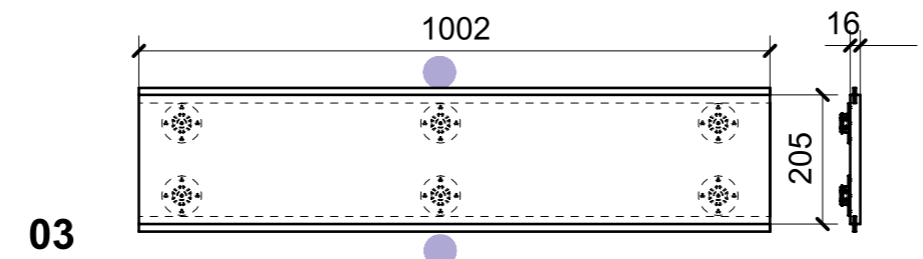
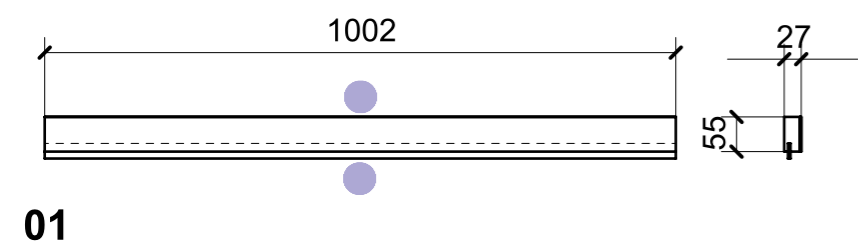

VERNICIATURA LASTRA/LACCATI:
● = VERNICIARE 1 LATO + FILI RASATI O BORDATI NESSUN SIMBOLO = VERNICIARE 2 LATI + FILI RASATI O BORDATI

LOCALE	CODICE	DESCRIZIONE COMPONENTE	FINITURA	Q.TA
LOBBY	MD298_MG_CI01	RIV. PARETE SX DISCESA SCALA	LACCATO BIANCO PERLA RAL 1013	1

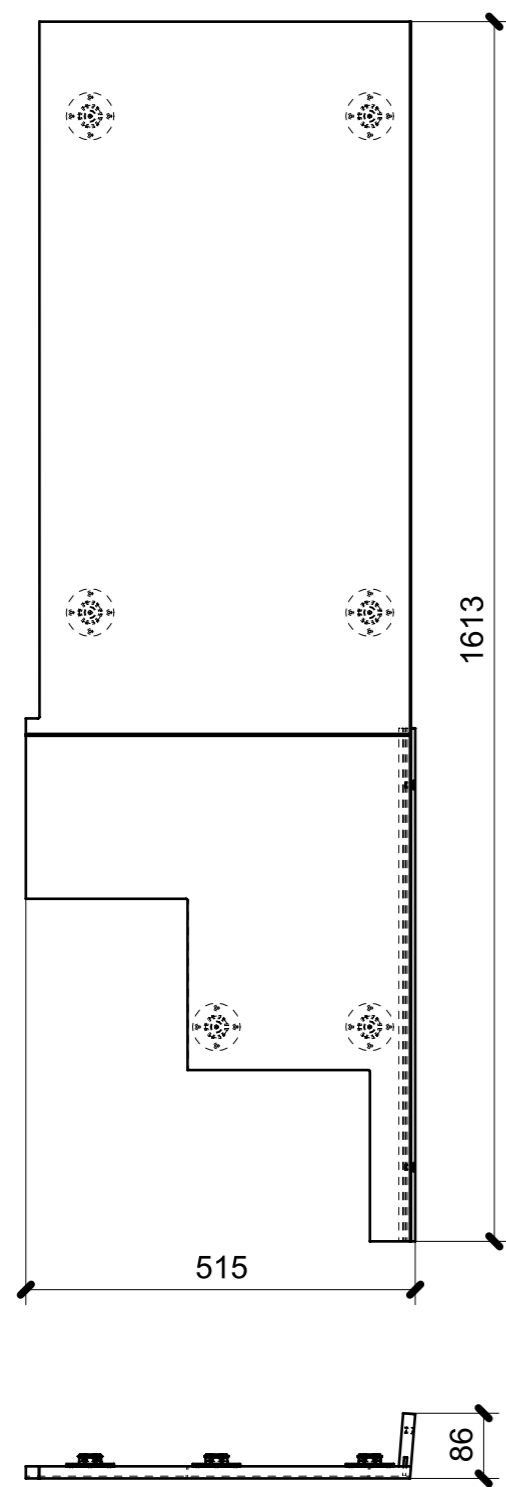

MG_CI01

FERRAMENTA	QTY
FITLOCK M_MASCHERPA_3MM_6020202101	6
BUSSOLA 5MA X 10 FORO DIAM.8	2

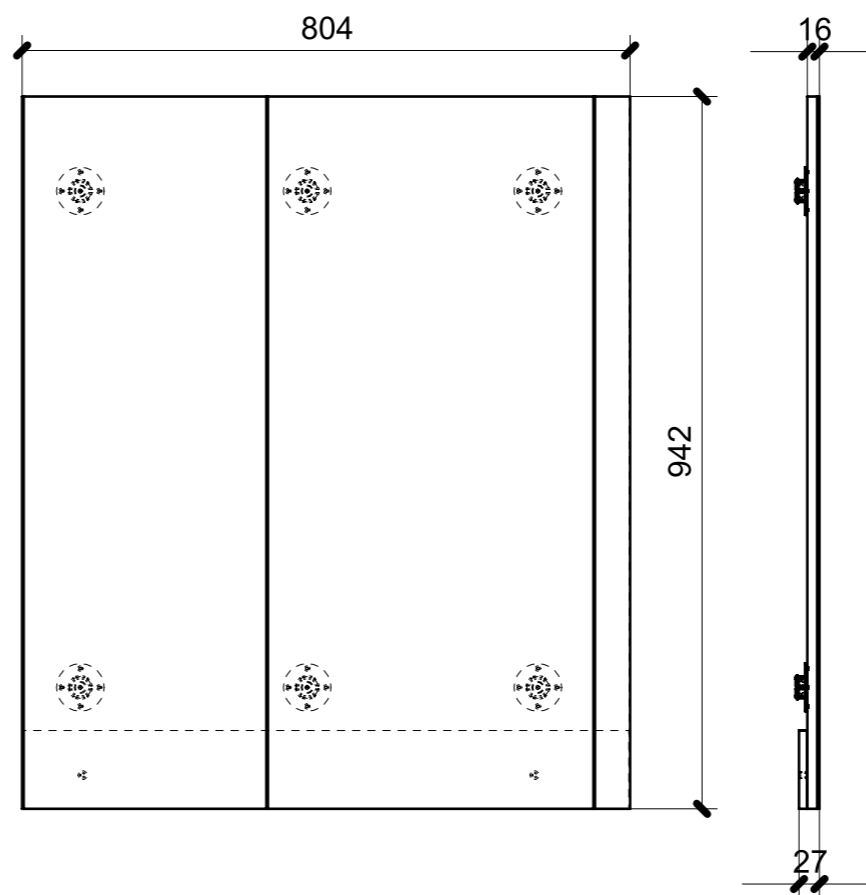

MG_CI02

FERRAMENTA	QTY
FITLOCK M_MASCHERPA_3MM_6020202101	6
BUSSOLA 5MA X 10 FORO DIAM.8	2

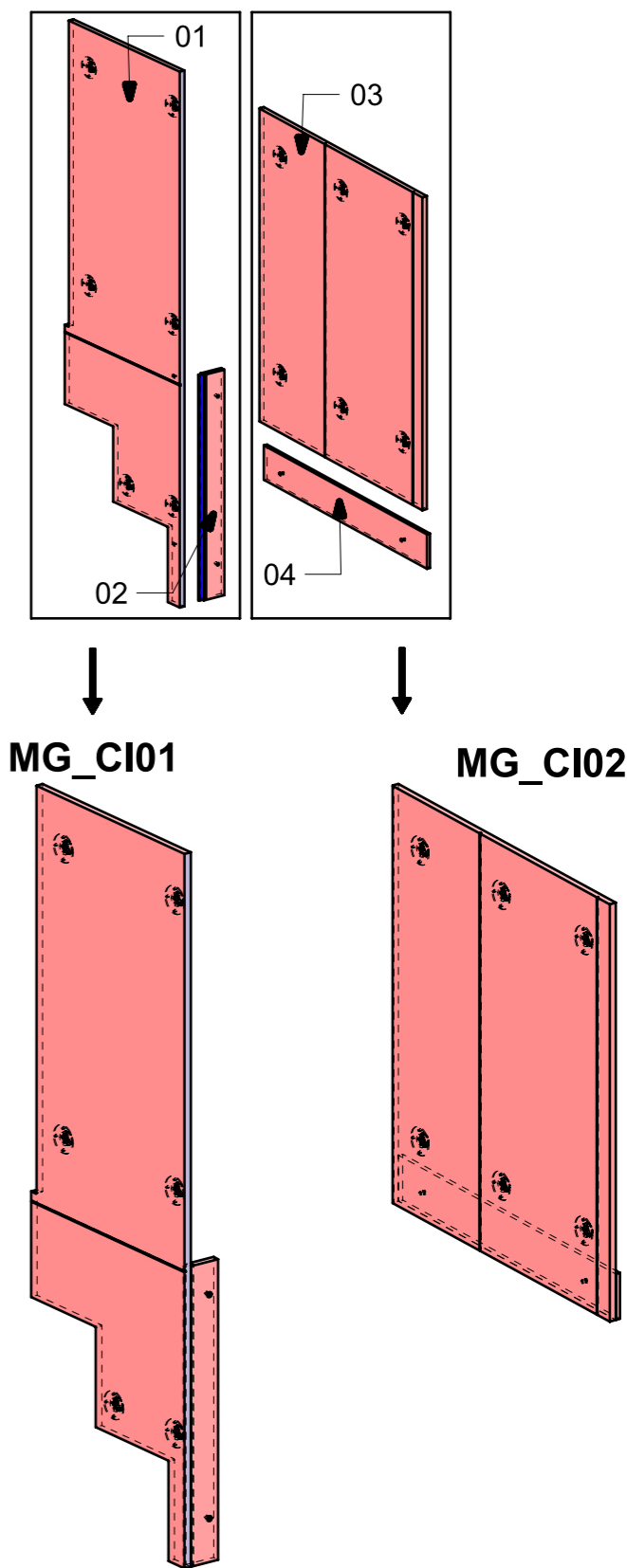

LOCALE	CODICE	DESCRIZIONE COMPONENTE	FINITURA	Q.TA
LOBBY	MD298_L01_CI01	RIV. PARETE SX DISCESA SCALA	LACCATO BIANCO PERLA RAL 1013	1

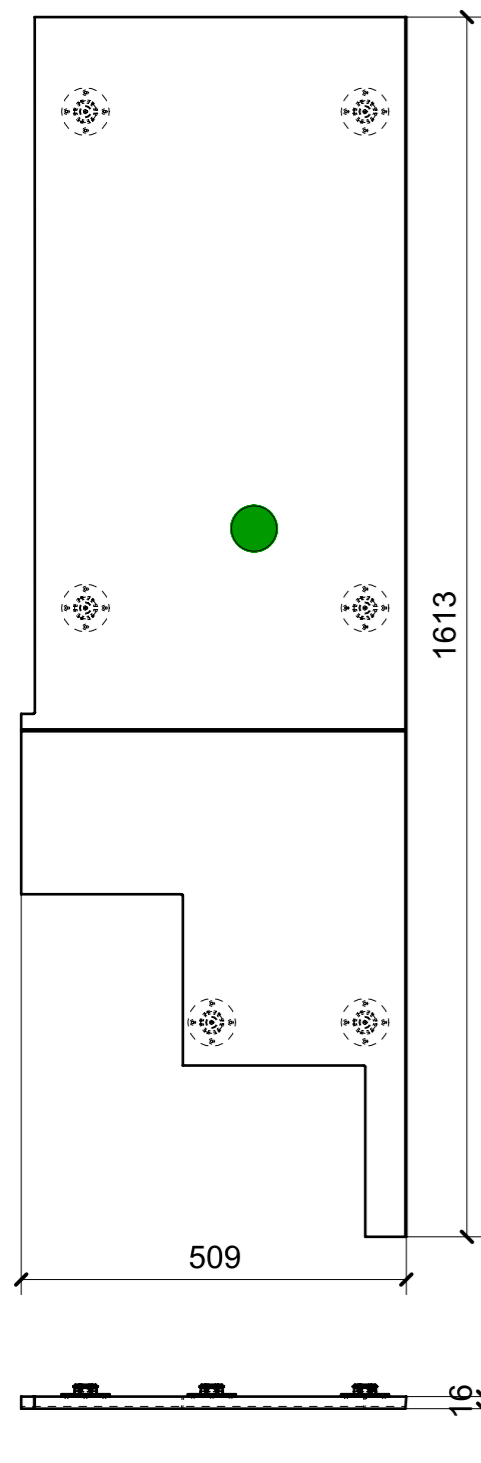

01

FERRAMENTA	QTY
FITLOCK M_MASCHERPA_3MM_6020202101	6

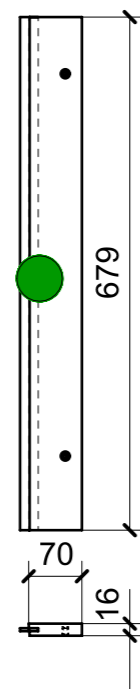

02

FERRAMENTA	QTY
BUSSOLA 5MA X 10 FORO DIAM.8	2

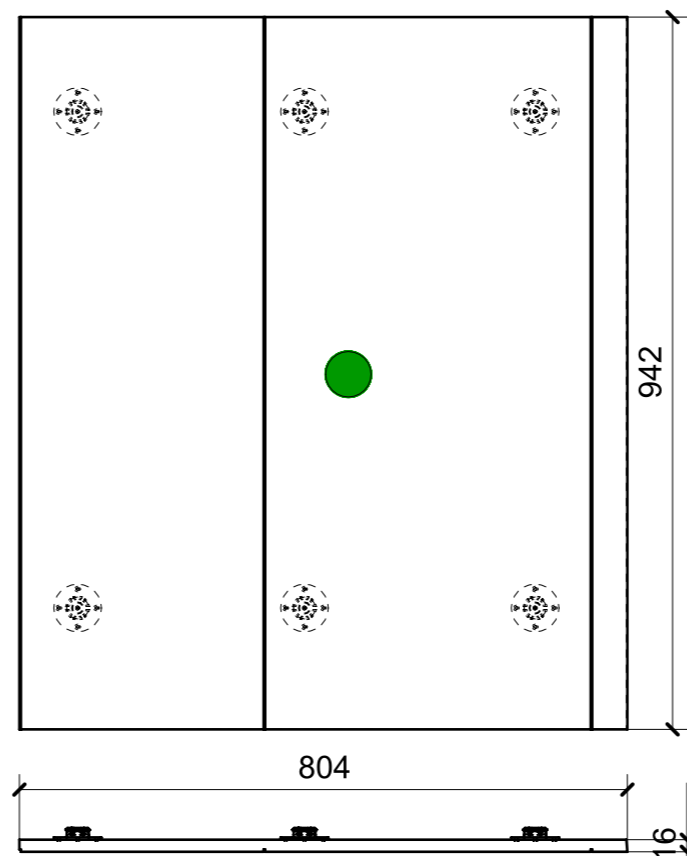

03

FERRAMENTA	QTY
FITLOCK M_MASCHERPA_3MM_6020202101	6

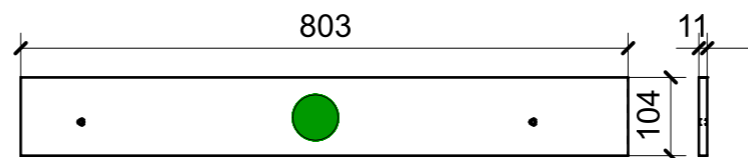

04

FERRAMENTA	QTY
BUSSOLA 5MA X 10 FORO DIAM.8	2

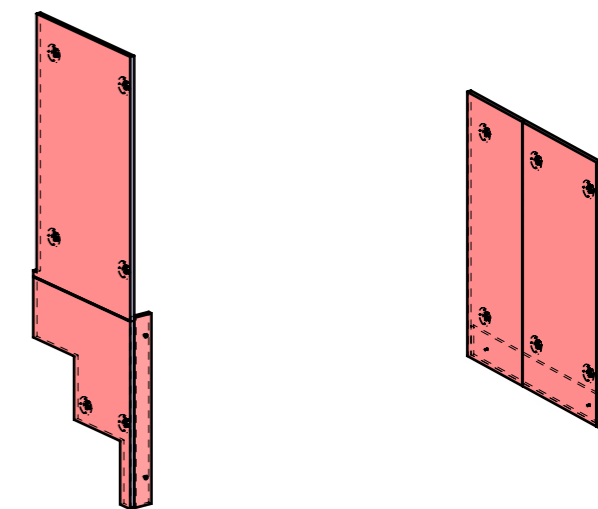

ELEMENTI DA MONTARE
in MG_CI01
e spedire con unico imballo

ELEMENTI DA MONTARE
in MG_CI02
e spedire con unico imballo

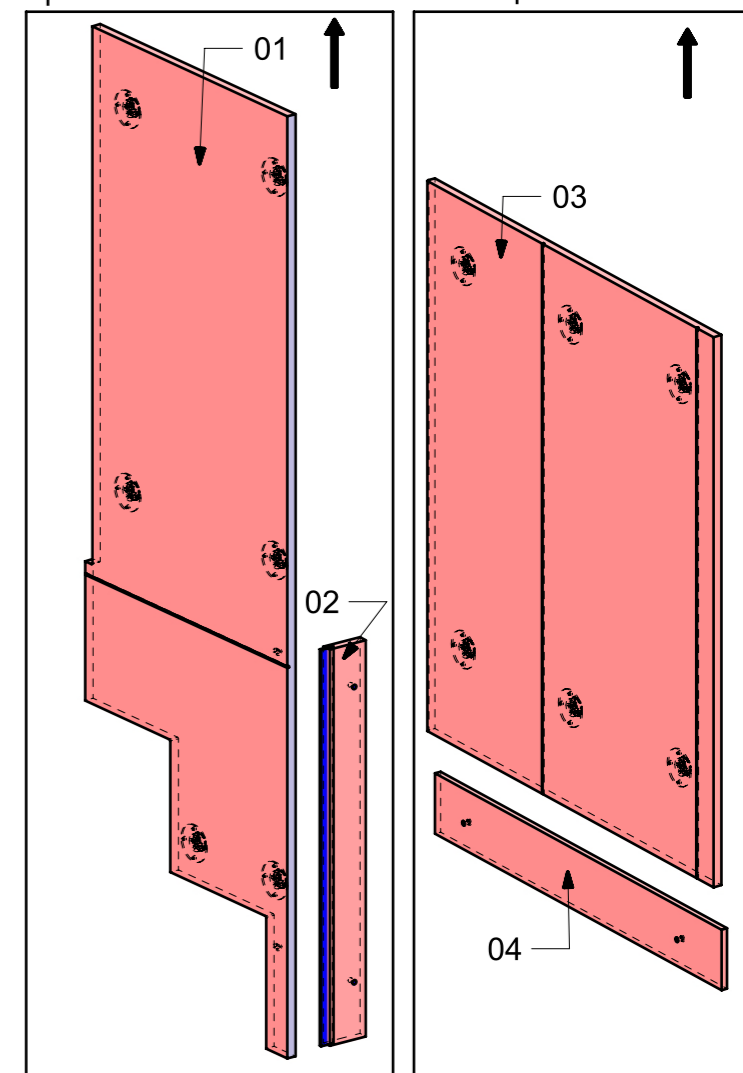

VERNICIATURA LASTRA/LACCATI:

● = VERNICIARE 1 LATO + FILI RASATI O BORDATI

NESSUN SIMBOLO = VERNICIARE 2 LATI + FILI RASATI O BORDATI

LOCALE	CODICE	DESCRIZIONE COMPONENTE	FINITURA	Q.TA
LOBBY	MD298_L01_CL01	RIV. PARETE DX DISCESA SCALA	LACCATO BIANCO PERLA RAL 1013	1

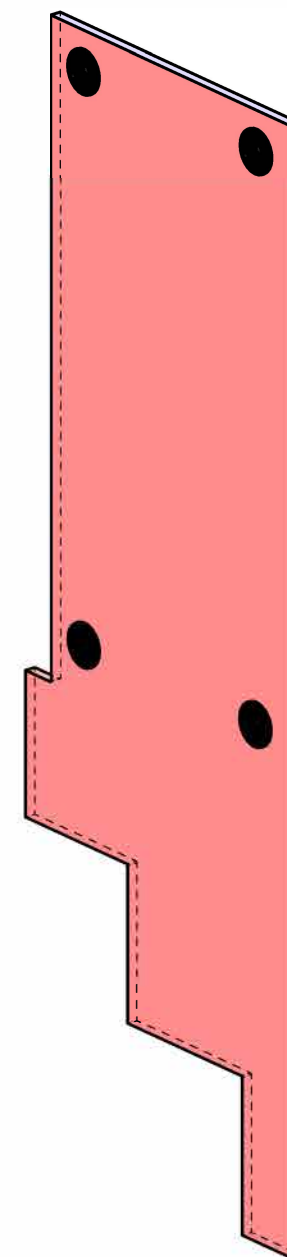
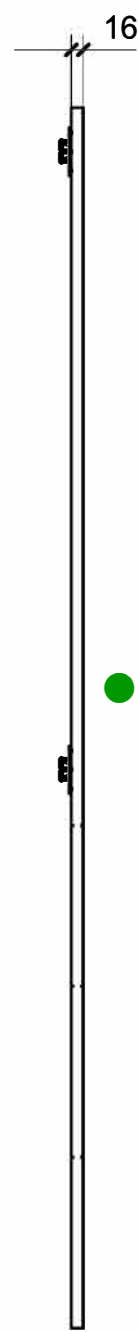
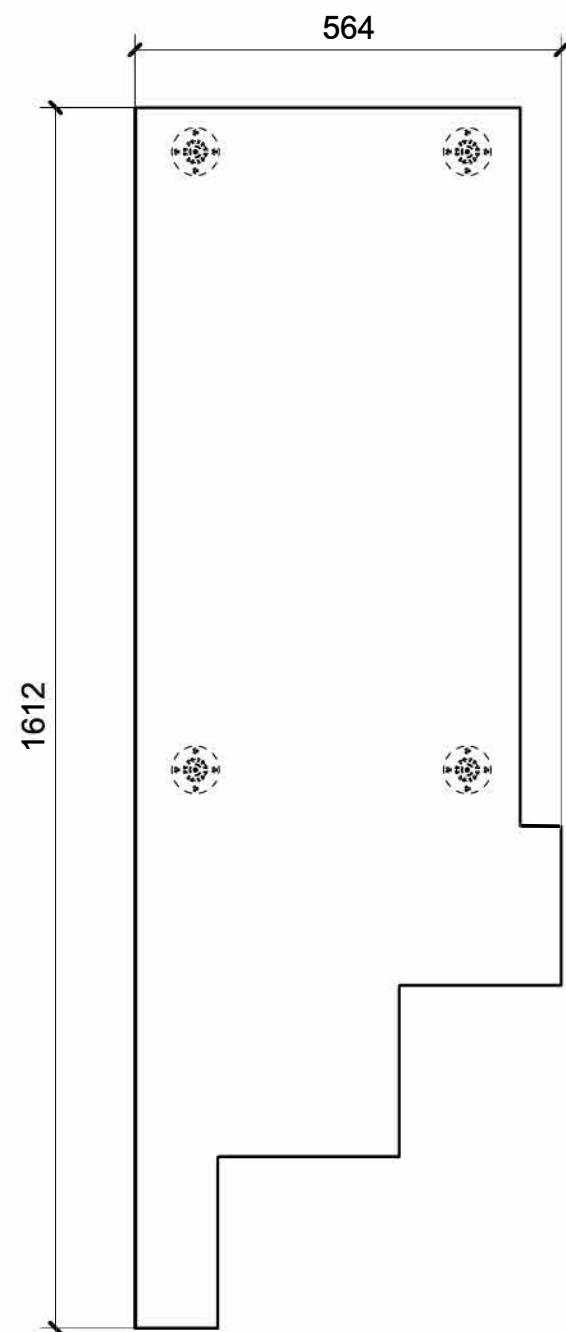

FERRAMENTA	QTY
FITLOCK M_MASCHERPA_3MM_6020202101	4

VERNICIATURA LASTRA/LACCATI:

● = VERNICIARE 1 LATO + FILI RASATI O BORDATI

NESSUN SIMBOLO = VERNICIARE 2 LATI + FILI RASATI O BORDATI

LOCALE	CODICE	DESCRIZIONE COMPONENTE	FINITURA	Q.TA
LOBBY	MD298_L01_CM01	RIV. PARETE FRONTE DISCESA SCALA	LACCATO BIANCO PERLA RAL 1013	1

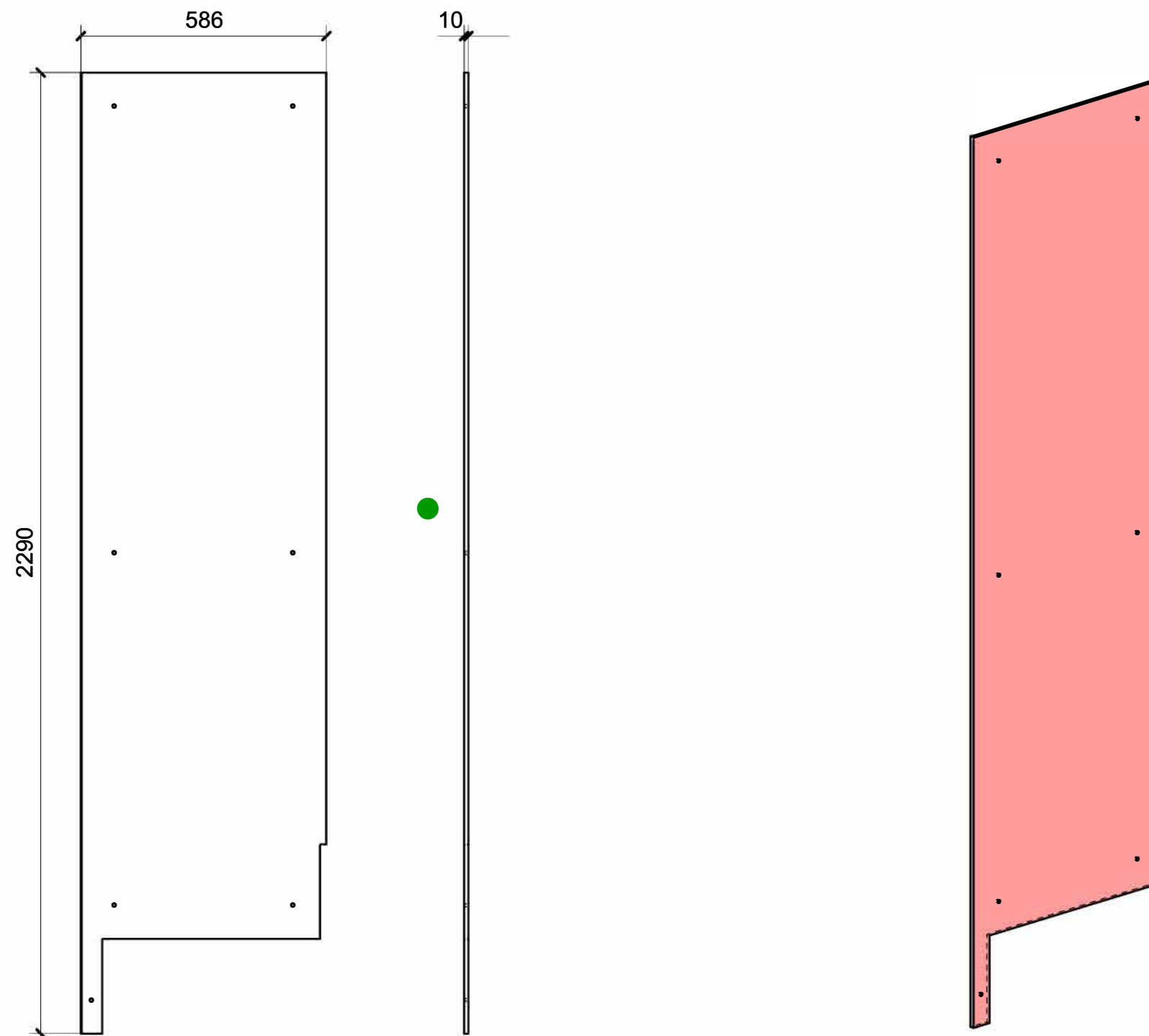

VERNICIATURA LASTRA/LACCATI:

● = VERNICIARE 1 LATO + FILI RASATI O BORDATI

NESSUN SIMBOLO = VERNICIARE 2 LATI + FILI RASATI O BORDATI

LOCALE	CODICE	DESCRIZIONE COMPONENTE	FINITURA	Q.TA
LOBBY	MD298_R01_CN01	RIV. LATERALE PORTA ARMATORE	LASTRA CHIARA	1

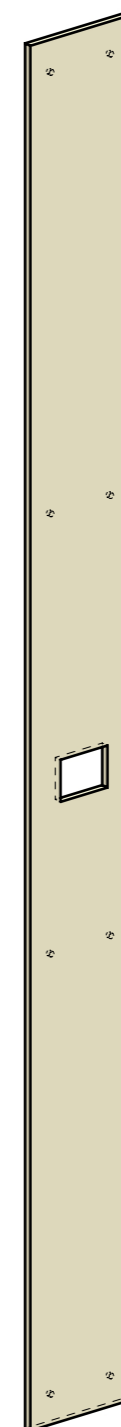
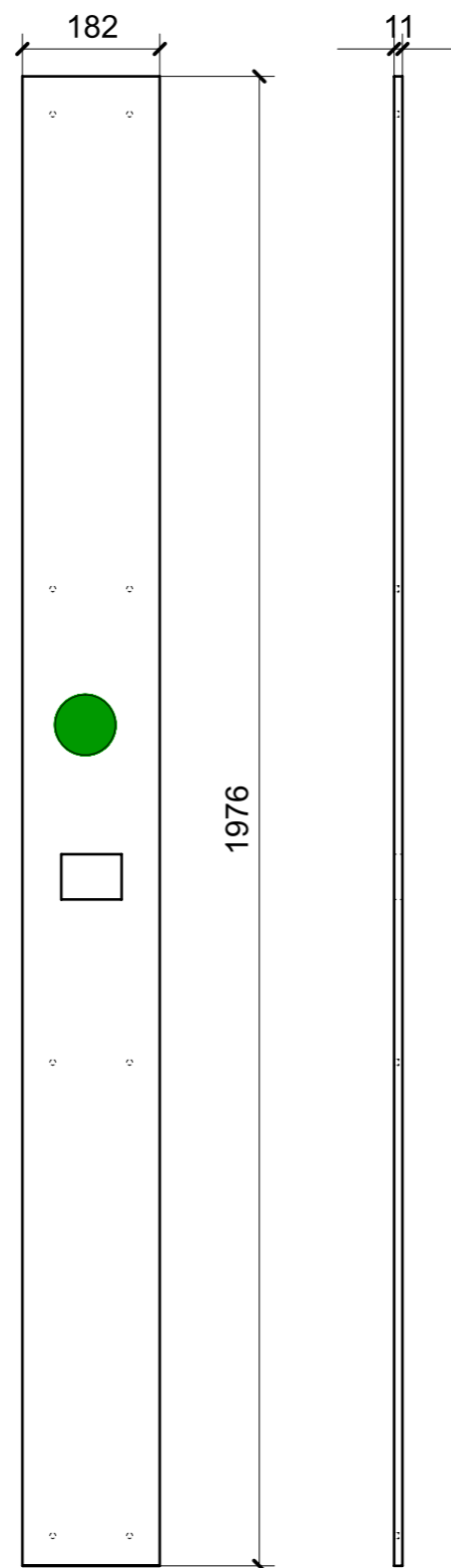

VERNICIATURA LASTRA/LACCATI:

● = VERNICIARE 1 LATO + FILI RASATI O BORDATI

NESSUN SIMBOLO = VERNICIARE 2 LATI + FILI RASATI O BORDATI

LOCALE	CODICE	DESCRIZIONE COMPONENTE	FINITURA	Q.TA
LOBBY	MD298_R01_CO01	RIV. PARATIA BAGNO VIP	LASTRA CHIARA	1

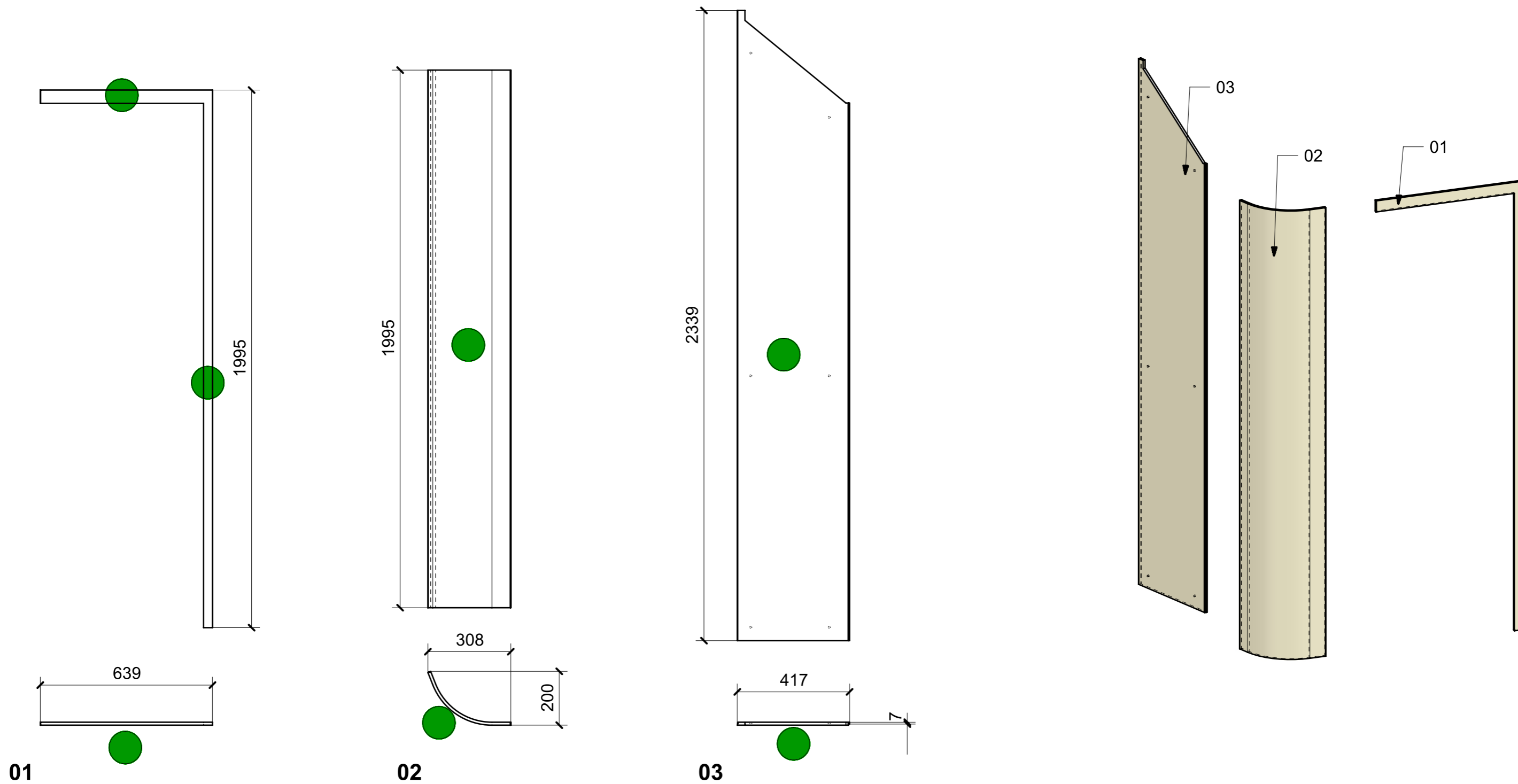

VERNICIATURA LASTRA/LACCATI:

● = VERNICIARE 1 LATO + FILI RASATI O BORDATI

NESSUN SIMBOLO = VERNICIARE 2 LATI + FILI RASATI O BORDATI

LOCALE	CODICE	DESCRIZIONE COMPONENTE	FINITURA	Q.TA
LOBBY	MD298_R01_CP01	RIV. TELAIO PORTA OSPITI	LASTRA CHIARA	1

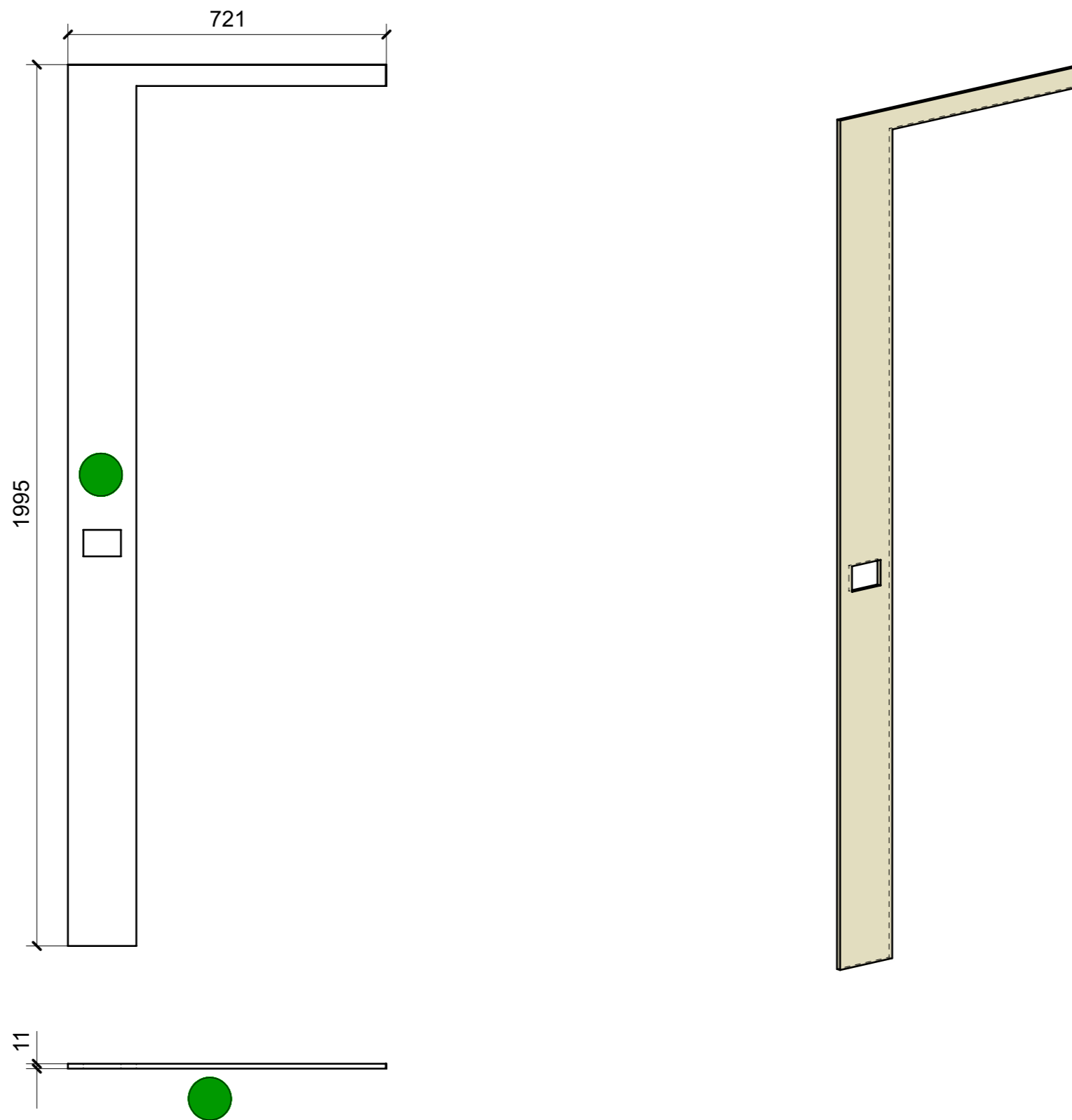

VERNICIATURA LASTRA/LACCATI:

● = VERNICIARE 1 LATO + FILI RASATI O BORDATI

NESSUN SIMBOLO = VERNICIARE 2 LATI + FILI RASATI O BORDATI