

| LOCALE | CODICE | DESCRIZIONE COMPONENTE | FINITURA | GR |
|--------|---------------|------------------------|----------|----|
| LOBBY | MD298_MF_CF01 | MOBILE WINE COOLER | | 8 |

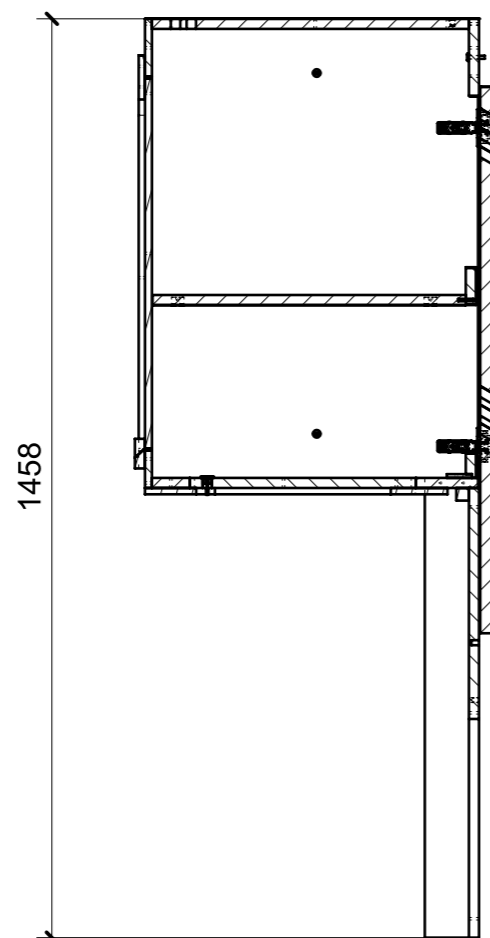

SECTION J-J

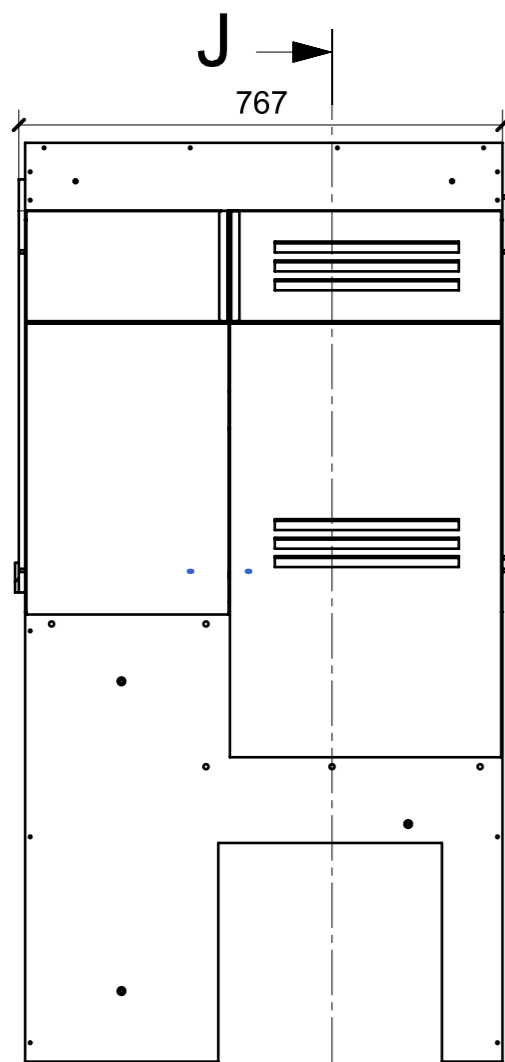
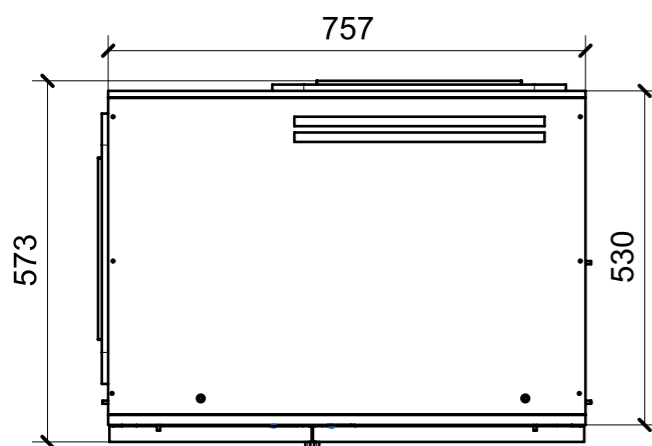

| FERRAMENTA | QTY |
|--|-----|
| VITE 4MA X 30 TESTA SVASATA ESAGONALE NERA | 4 |
| BASE_3-NERA_HAFELE_342.22.067-BLUM_175H3130.STP | 4 |
| COPERTURA BRACCIO CERNIERA NERO-HAFELE_342.94.602-BLUM_70.1503.STP | 4 |
| VITE 5MA X 25 TESTA SVASATA | 4 |
| BUSSOLA 6MA X 10 FORO DIAM.8 | 5 |
| VITE 5MA X 25 TESTA BOMBATA | 4 |
| CERNIERA 94° PIANA-NERA_HAFELE_342.46.604-BLUM_71B9550.STP | 4 |
| BUSSOLA 5MA ANKOR BORGHI | 18 |
| COPERTURA GABBIA CERNIERA NERO_HAFE_342.45.032-BLUM_70T3504.STP | 4 |
| VITE 4MAX8 ANKOR BORGHI | 18 |
| CALAMITA SEALED MAGNETIC_TECNOPARTNER_MC-JM50-BL | 2 |
| ALZAPAGLIOLI_FORESTI_164.C | 1 |
| GOMMINO PARACOLPO ANTA | 4 |
| PLACCHETTA COUNTER STEEL_TECNOPARTNER_MC-JM49 | 2 |
| MANIGLIA X MOBILE PAMAR_FBC BORGHI_886Z-175 ALOP | 2 |

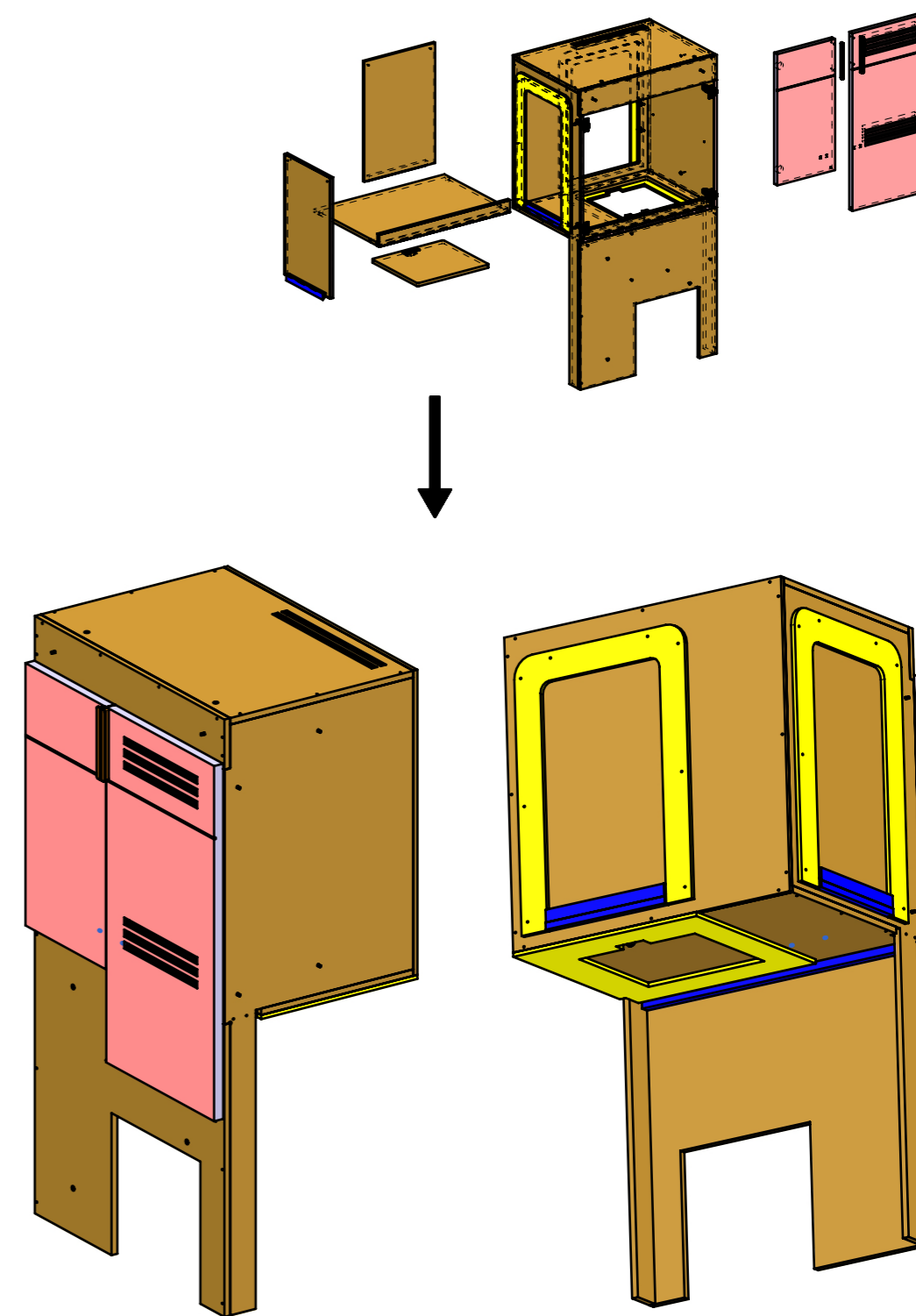

| LOCALE | CODICE | DESCRIZIONE COMPONENTE | FINITURA | GR |
|--------|------------|------------------------|-----------------------------------|----|
| LOBBY | MD298_CF01 | MOBILE WINE COOLER | LAMINATO LG23 PORO ROVERE\ GREZZO | 8 |

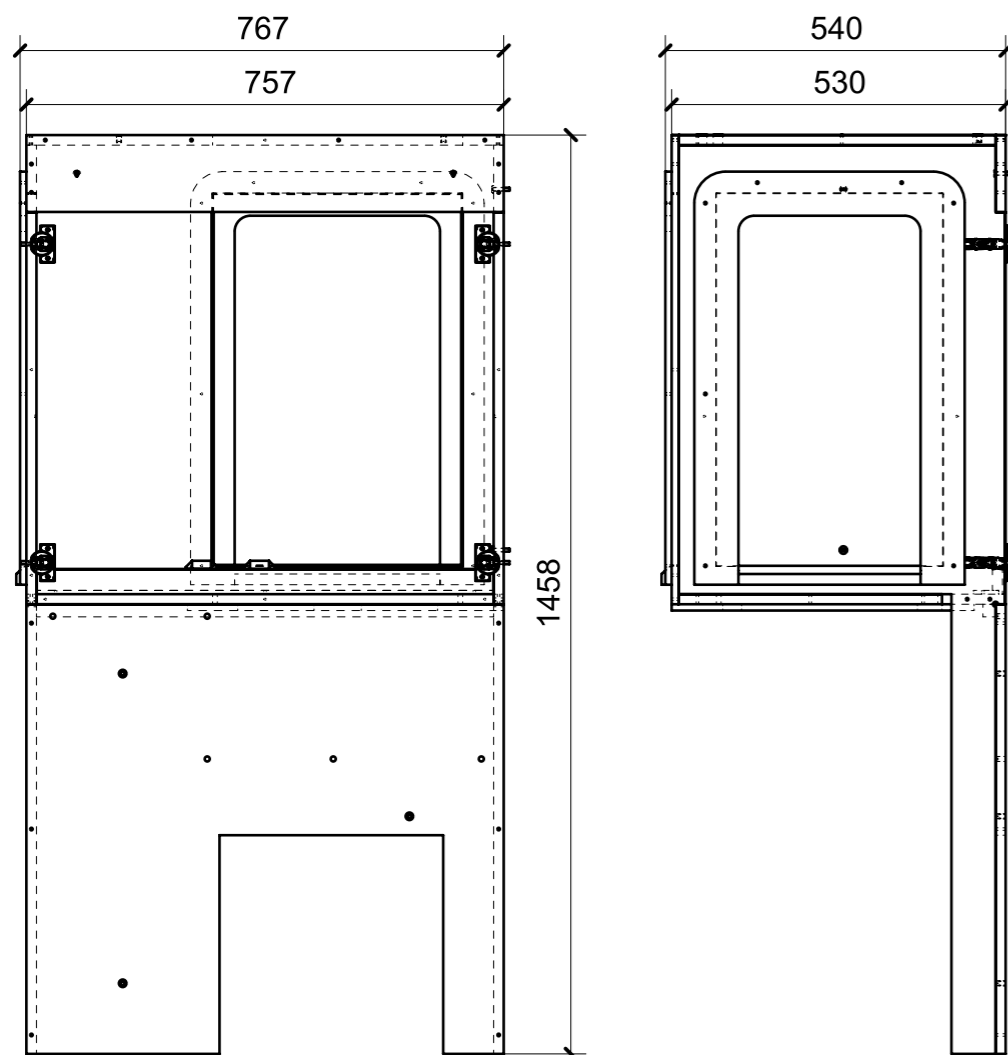

01

| FERRAMENTA | QTY |
|--|-----|
| BASE_3-NERA_HAFELE_342.22.067-BLUM_175H3130.STP | 4 |
| BUSSOLA 5MA ANKOR BORGHI | 18 |
| BUSSOLA 6MA X 10 FORO DIAM.8 | 5 |
| CALAMITA SEALED MAGNETIC_TECNOPARTNER_MC-JM50-BL | 2 |
| CERNIERA 94°_PIANA-NERA_HAFELE_342.46.604-BLUM_71B9550.STP | 4 |
| COPERTURA BRACCIO CERNIERA NERO-HAFELE_342.94.602-BLUM_70.1503.STP | 4 |
| COPERTURA GABBIA CERNIERA NERO_HAFE_342.45.032-BLUM_70T3504.STP | 4 |
| VITE 4MAX8 ANKOR BORGHI | 18 |
| VITE 5MA X 25 TESTA BOMBATA | 4 |
| VITE 5MA X 25 TESTA SVASATA | 4 |

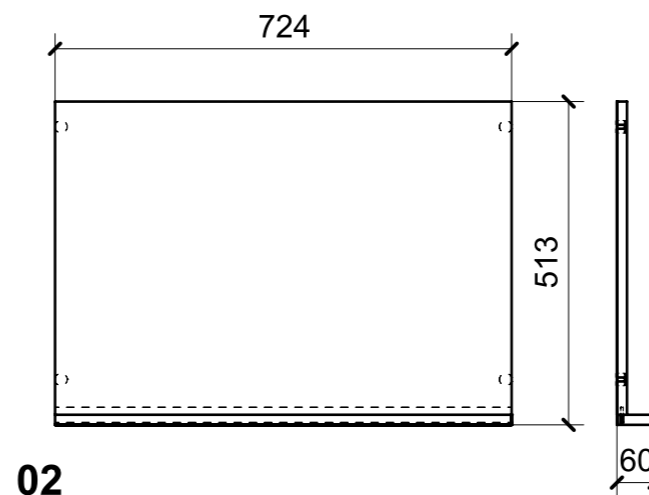

02

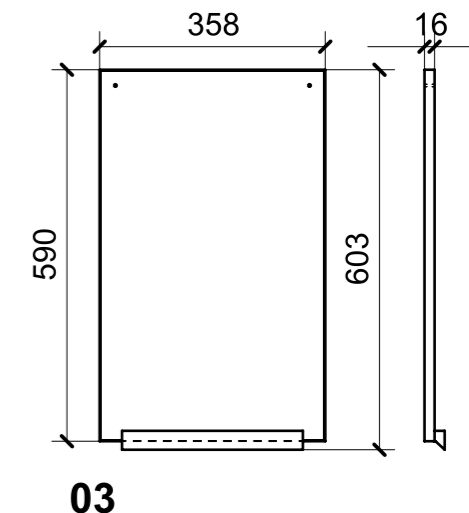

03

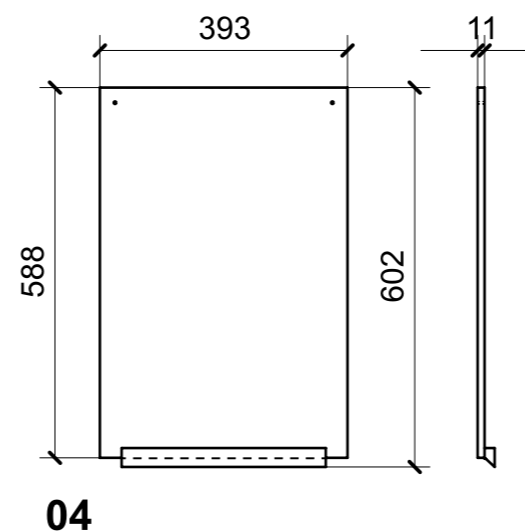

04

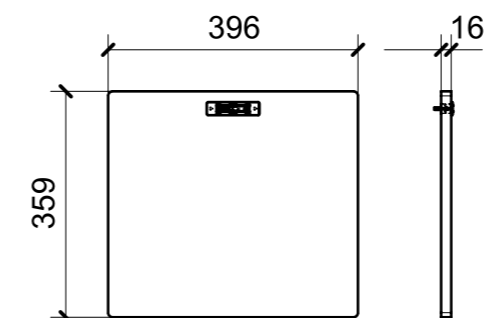

05

| FERRAMENTA | QTY |
|----------------------------|-----|
| ALZAPAGLIOLI_FORESTI_164.C | 1 |

ELEMENTI DA MONTARE
con L01_CF01_01-->02 in MF_CF01
e spedire con unico imballo

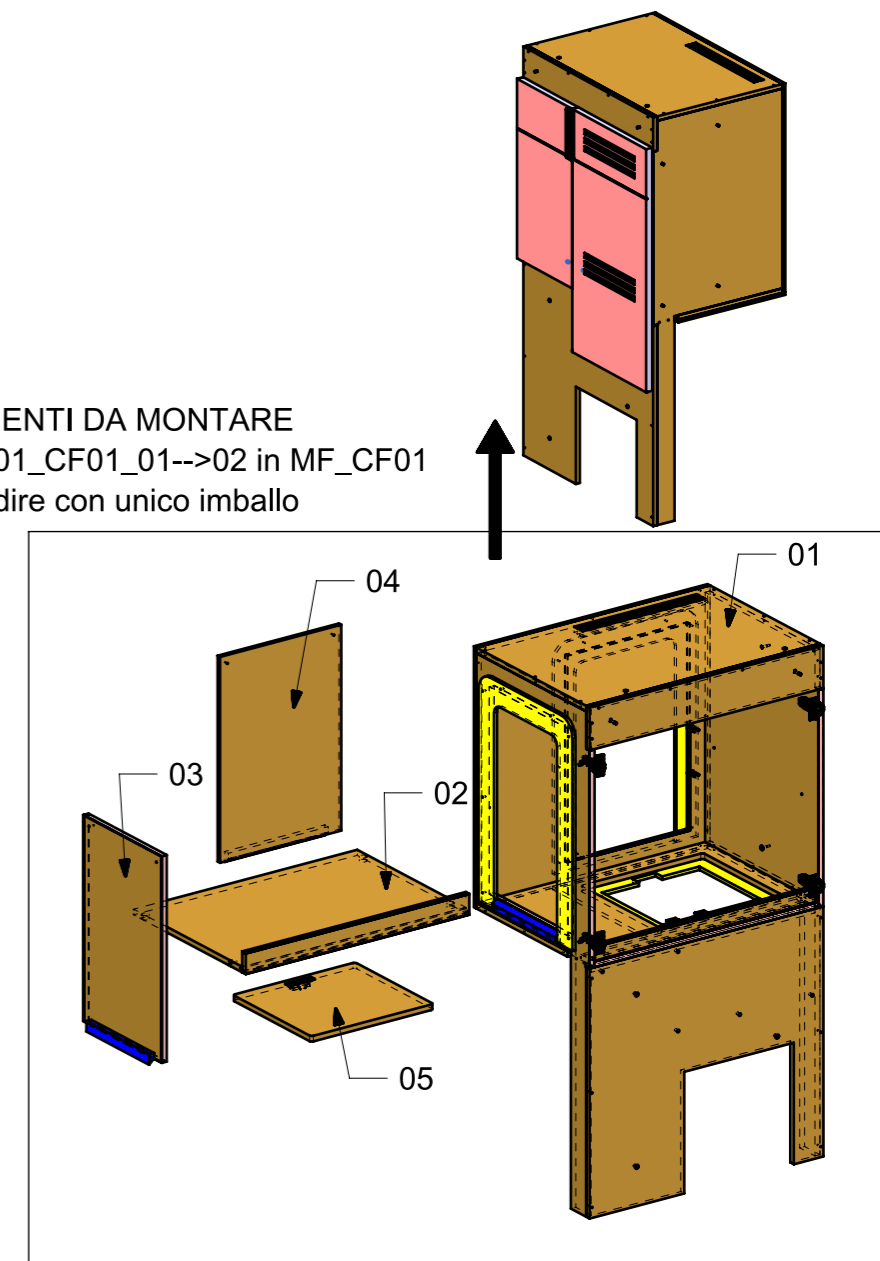

| LOCALE | CODICE | DESCRIZIONE COMPONENTE | FINITURA | GR |
|--------|----------------|------------------------|-------------------------------|----|
| LOBBY | MD298_L01_CF01 | MOBILE WINE COOLER | LACCATO BIANCO PERLA RAL 1013 | 8 |

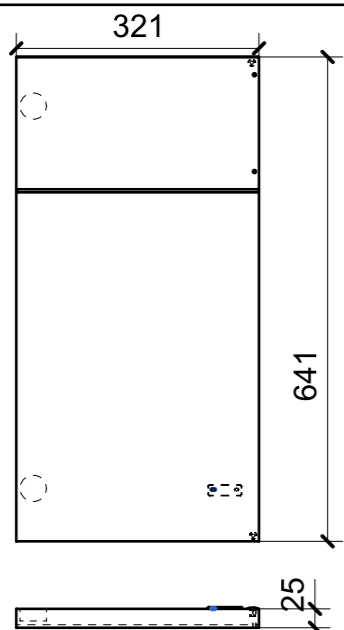

01

| FERRAMENTA | QTY |
|--|-----|
| GOMMINO PARACOLPO ANTA | 2 |
| PLACCHETTA COUNTER STEEL_TECHNOPARTNER_MC-JM49 | 1 |

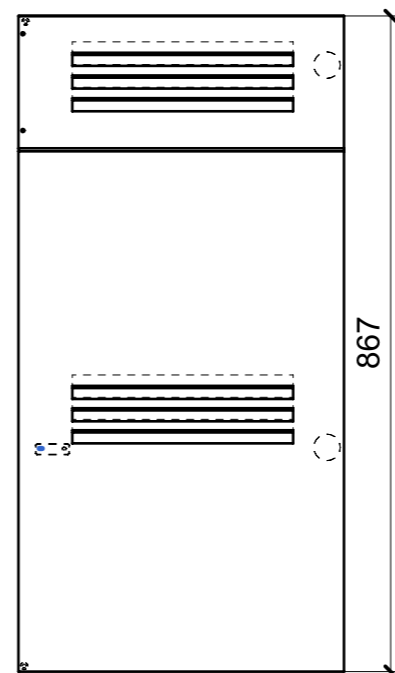

02

| FERRAMENTA | QTY |
|--|-----|
| GOMMINO PARACOLPO ANTA | 2 |
| PLACCHETTA COUNTER STEEL_TECHNOPARTNER_MC-JM49 | 1 |

01 02
ELEMENTI DA MONTARE
con CF01_01-->05 in MF_CF01
e spedire con unico imballo

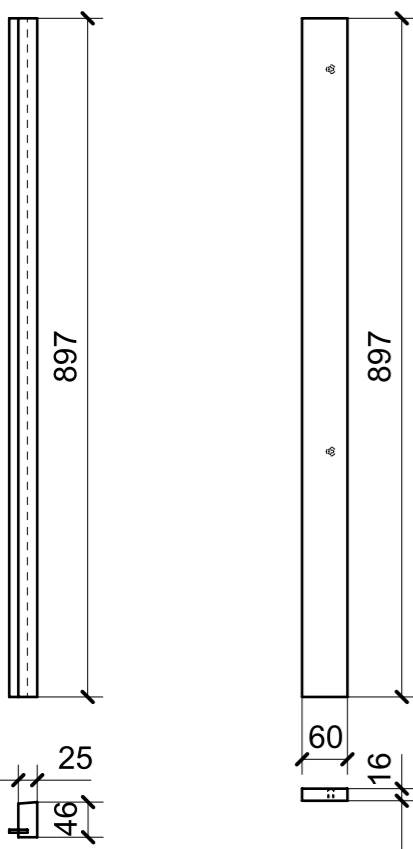

04

05

| FERRAMENTA | QTY |
|------------------------------|-----|
| BUSSOLA 5MA X 10 FORO DIAM.8 | 2 |

ELEMENTI DA MONTARE
in MG_CF01
e spedire con unico imballo

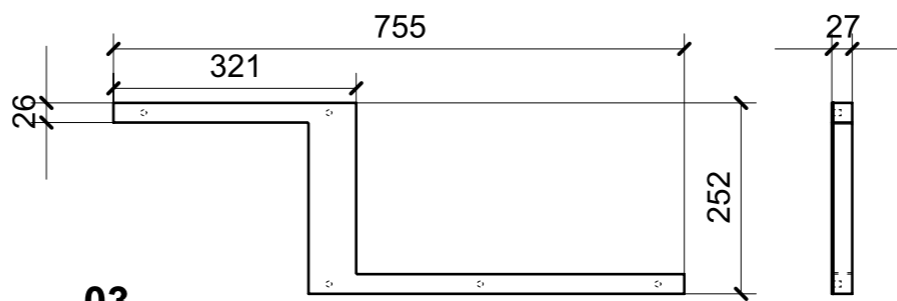

03

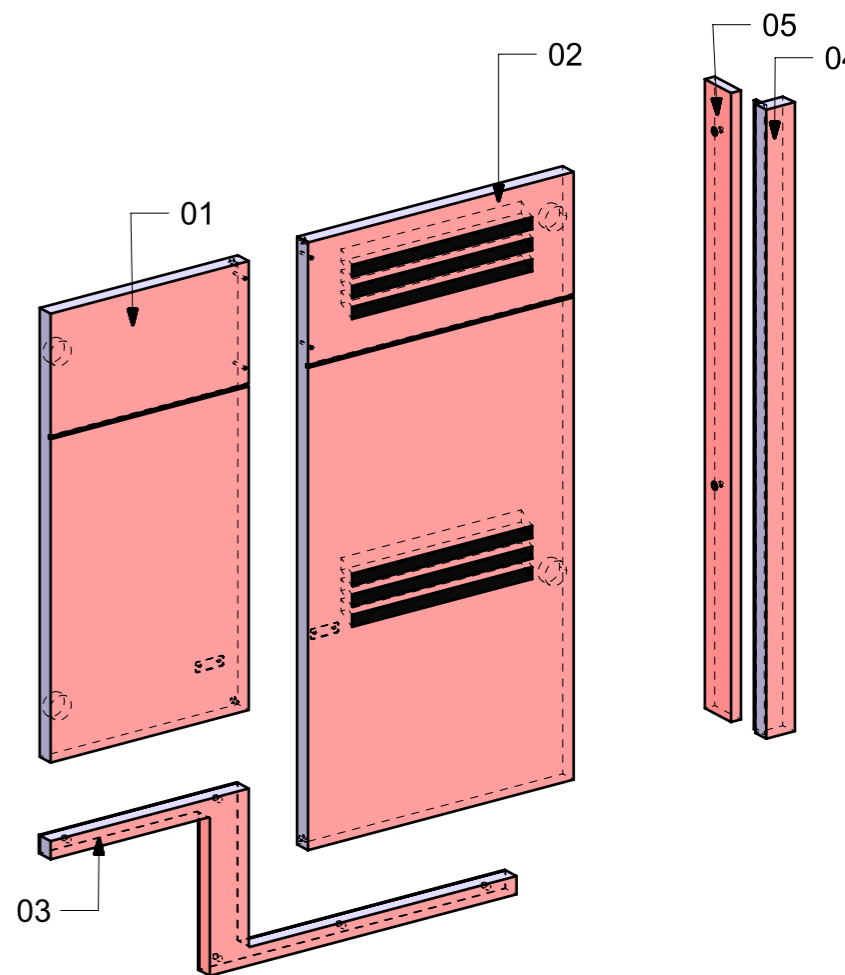

VERNICIATURA LASTRA/LACCATI:

● = VERNICIARE 1 LATO + FILI RASATI O BORDATI

NESSUN SIMBOLO = VERNICIARE 2 LATI + FILI RASATI O BORDATI

| LOCALE | CODICE | DESCRIZIONE COMPONENTE | FINITURA | Q.TA |
|--------|---------------|------------------------|-------------------------------|------|
| LOBBY | MD298_MG_CF01 | MOBILE WINE COOLER | LACCATO BIANCO PERLA RAL 1013 | 1 |

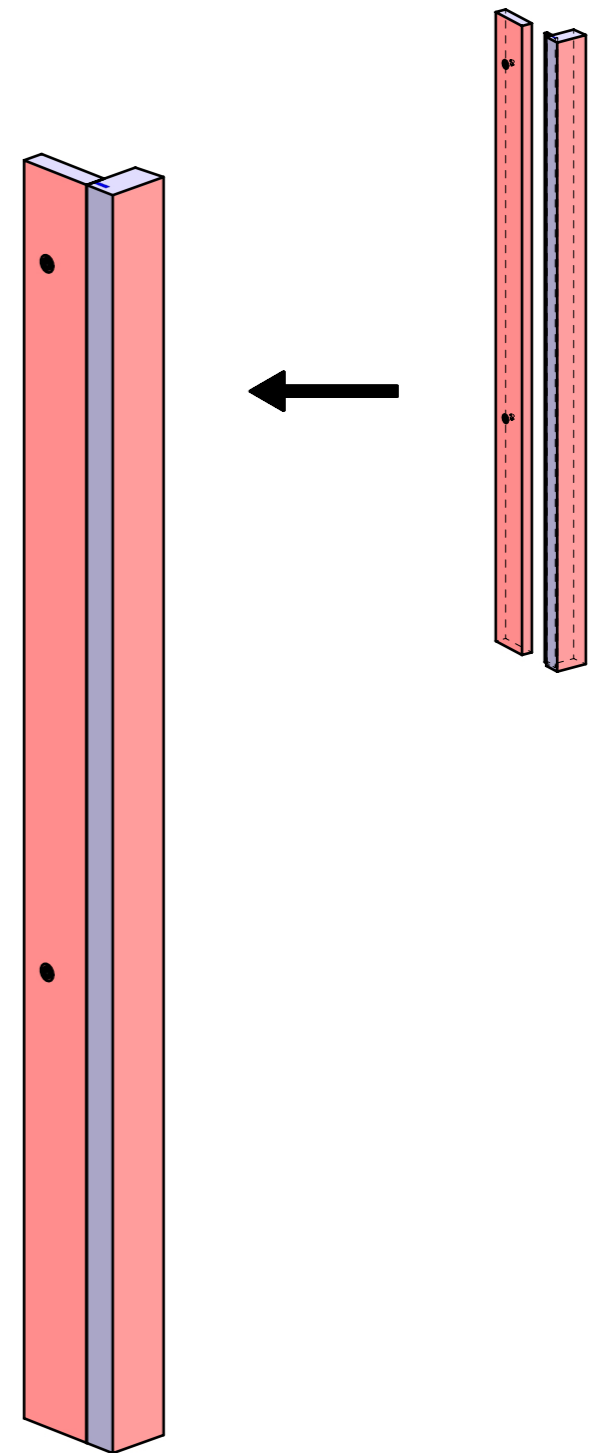
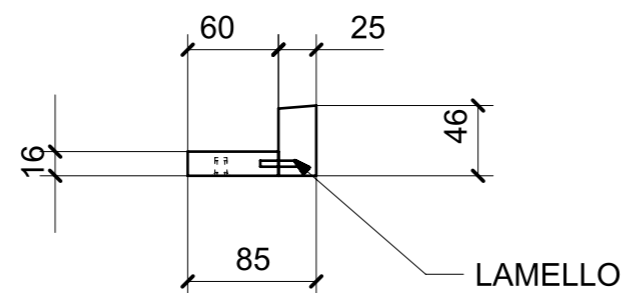
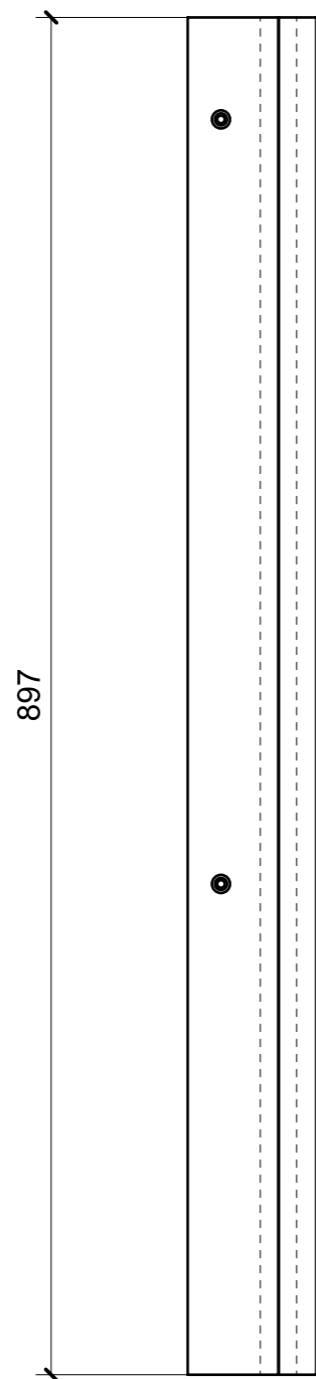

| FERRAMENTA | QTY |
|------------------------------|-----|
| BUSSOLA 5MA X 10 FORO DIAM.8 | 2 |

| LOCALE | CODICE | DESCRIZIONE COMPONENTE | FINITURA | GR |
|--------|----------------|------------------------|---------------------------------------|----|
| LOBBY | MD298_A01_CF01 | MOBILE WINE COOLER | MANIGLIA PAMAR VERN.serie 90MFY-01.02 | 8 |

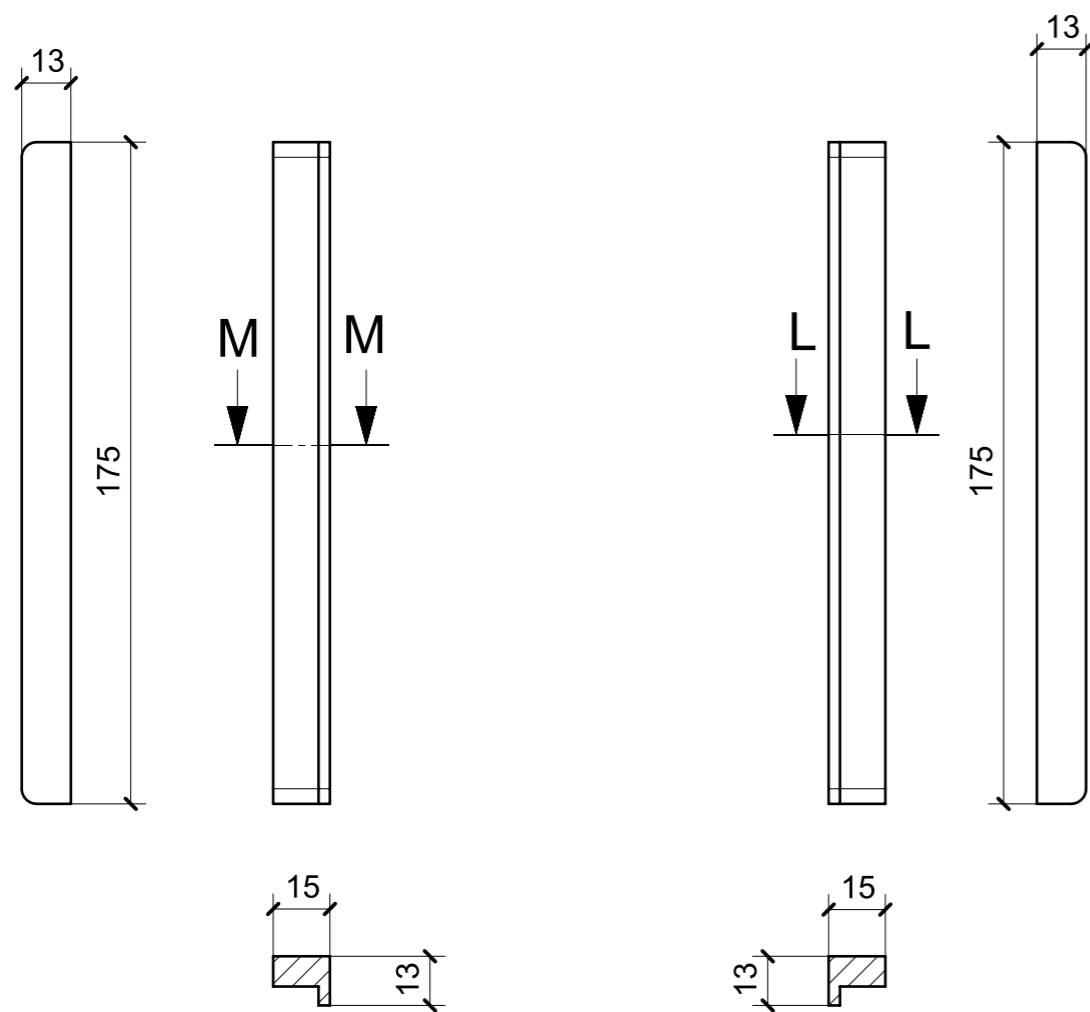

SECTION M-M

SECTION L-L

A_CF01_01

A_CF01_02

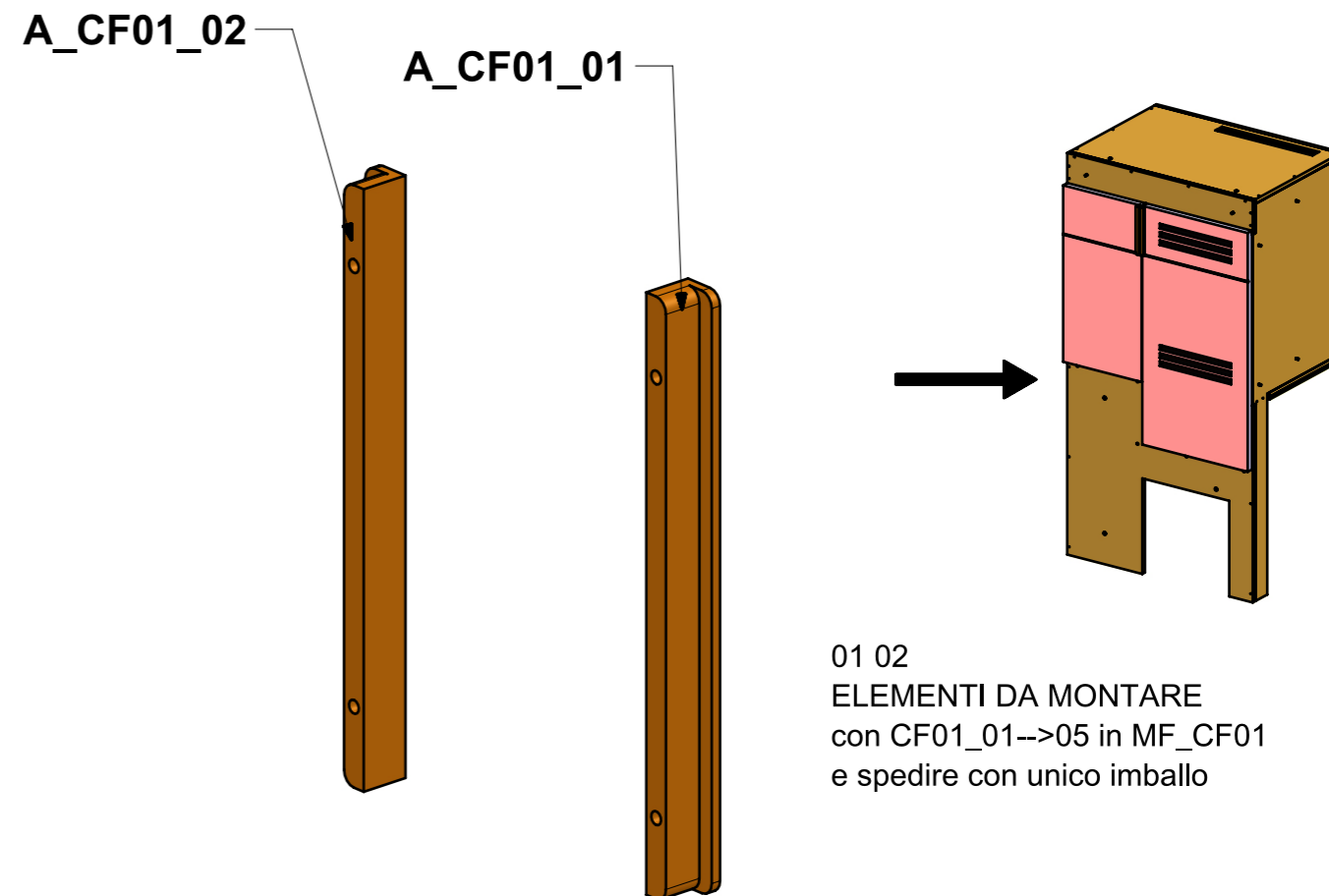

01 02
ELEMENTI DA MONTARE
con CF01_01-->05 in MF_CF01
e spedire con unico imballo

| LOCALE | CODICE | DESCRIZIONE COMPONENTE | FINITURA | Q.TA |
|--------|-------------|------------------------|---------------------------|------|
| LOBBY | MD298_CCF01 | MOBILE WINE COOLER_OPT | LAMINATO LG23 PORO ROVERE | 1 |

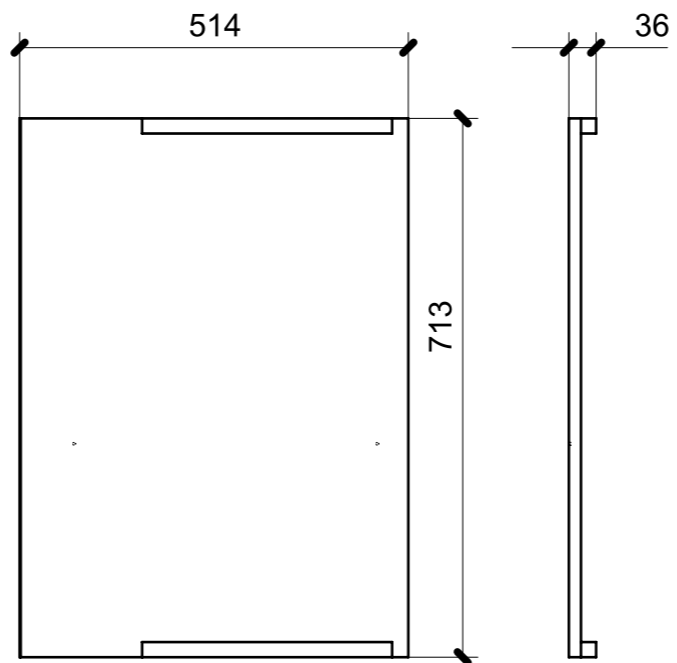
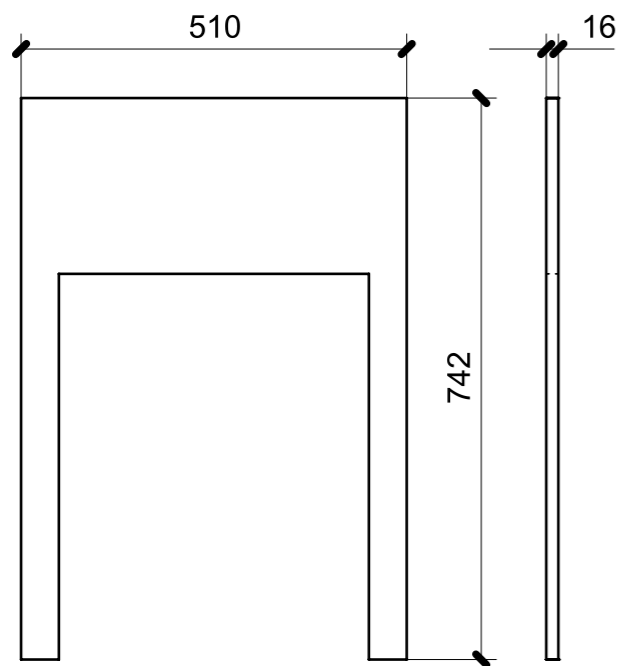

01

02

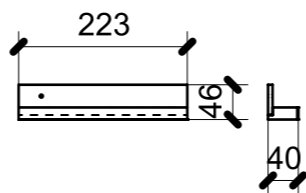
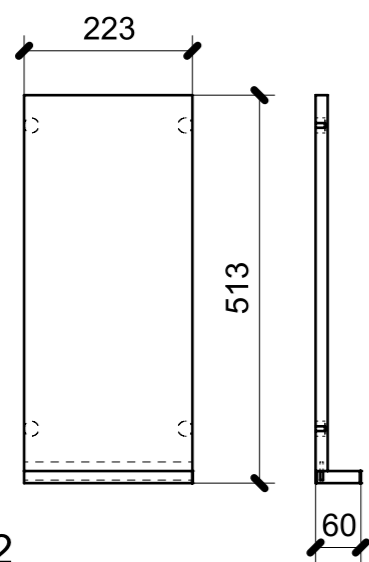

04

