

LOCALE	CODICE	DESCRIZIONE COMPONENTE	FINITURA	GR.
LOBBY	MD298_MF_CC01	ARMADIO SOTTOSCALA		8

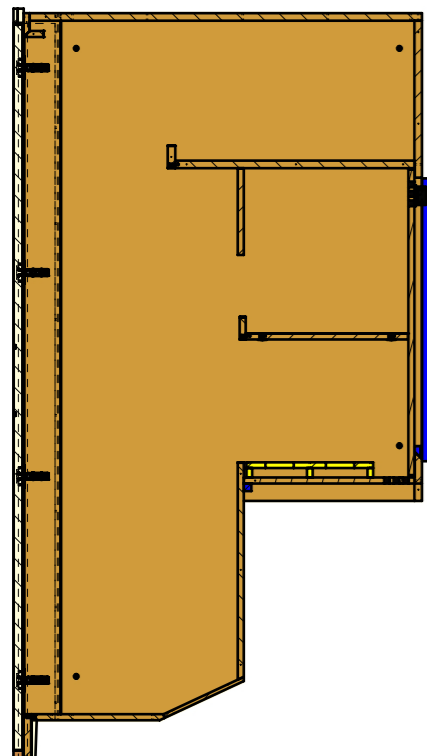

SECTION Y-Y

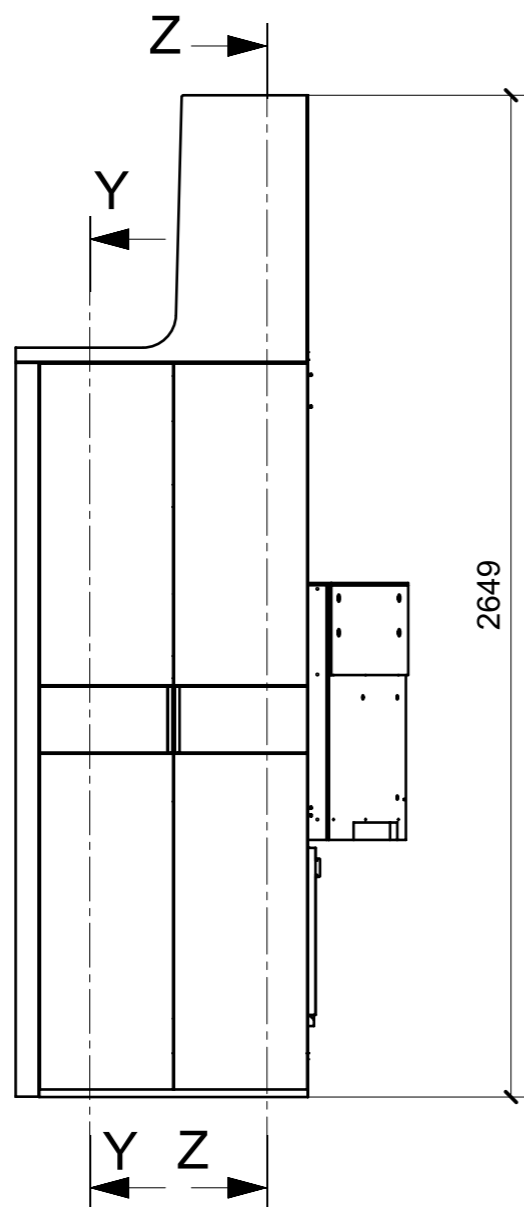

SECTION Z-Z

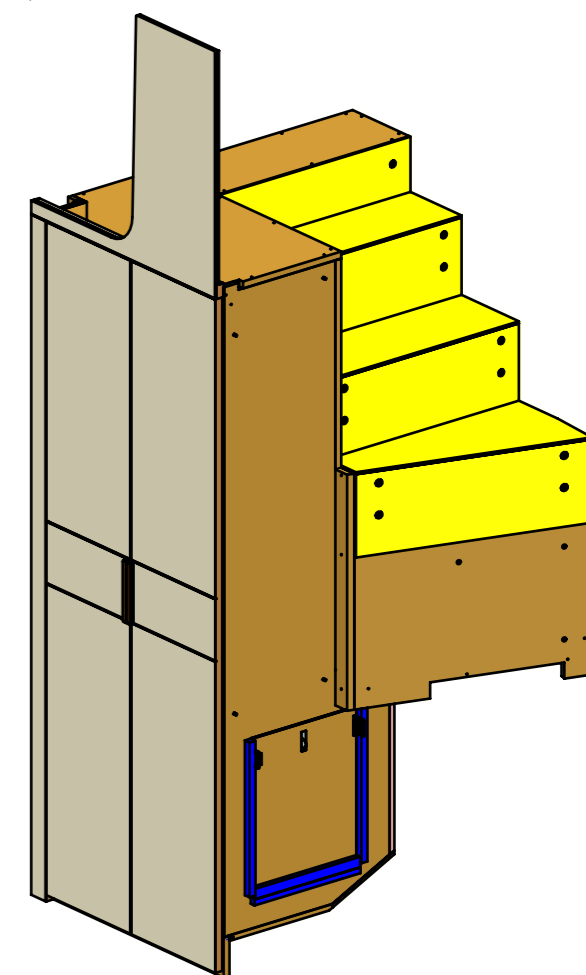
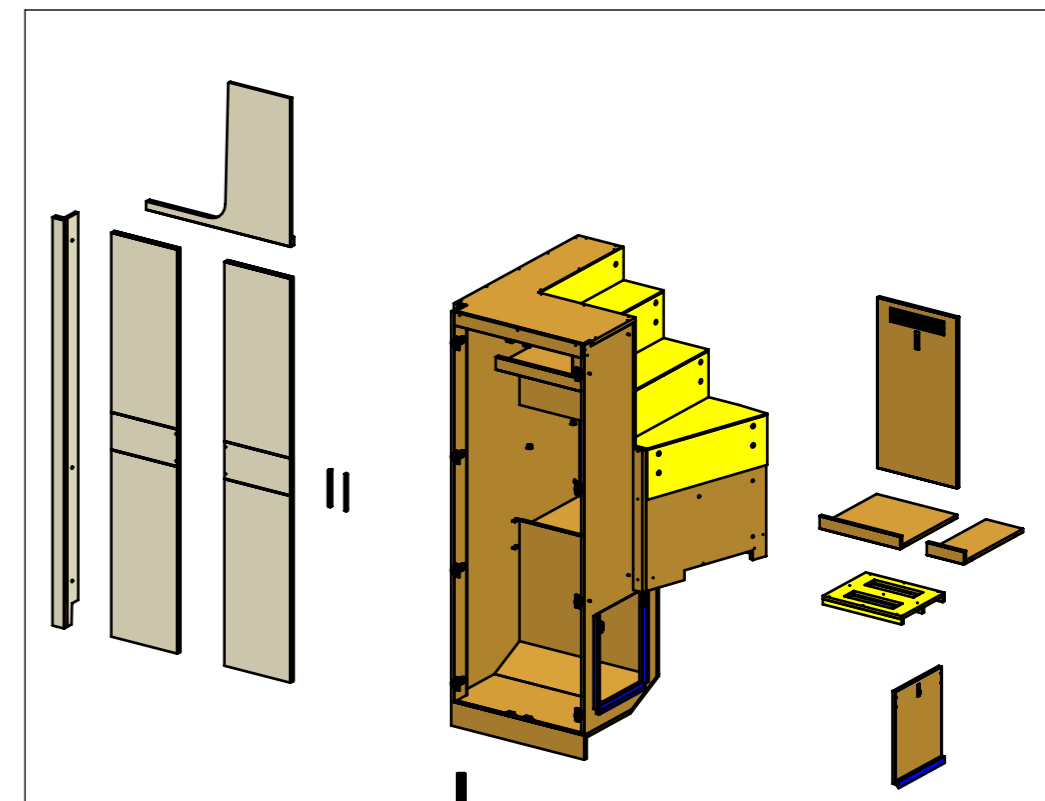
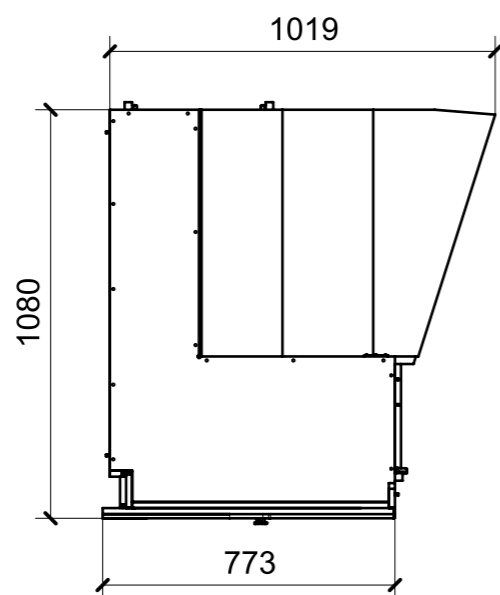

FERRAMENTA	QTY
ALZAPAGLIOLI_FORESTI_164.C	2
BASE_3-NERA_HAFELE_342.22.067-BLUM_175H3130.STP	8
BUSSOLA 5MA ANKOR BORGHI	32
BUSSOLA 5MA X 10 FORO DIAM.8	3
BUSSOLA 6MA X 10 FORO DIAM.8	5
CALAMITA SEALED MAGNETIC_TECNOPARTNER_MC-JM50-BL	4
CERNIERA 94°_PIANA-NERA_HAFELE_342.46.604-BLUM_71B9550.STP	8
CHIUSURA A SPINTA_TECNOPARTNER_SOU C3-203	4
COPERTURA BRACCIO CERNIERA NERO-HAFELE_342.94.602-BLUM_70.1503.STP	8
COPERTURA GABBIA CERNIERA NERO_HAFE_342.45.032-BLUM_70T3504.STP	8
FITLOCK F_MASCHERPA_6020101102	1
FITLOCK M_MASCHERPA_3MM_6020202101	1
GIUNTO REGGIRIPIANO_HAFELE_262.36.510	8
GOMMINO PARACOLPO ANTA	4
PLACCHETTA COUNTER STEEL_TECNOPARTNER_MC-JM49	4
VITE 4MA X 30 TESTA SVASATA ESAGONALE NERA	4
VITE 4MAX8 ANKOR BORGHI	32
VITE 5MA X 25 TESTA BOMBATA	2
VITE 5MA X 25 TESTA SVASATA	5
VITE 5MA X 30 TESTA BOMBATA	4

LOCALE	CODICE	DESCRIZIONE COMPONENTE	FINITURA	GR.
LOBBY	MD298_CC01	ARMADIO SOTTOSCALA	LAMINATO LG23 PORO ROVERE\ GREZZO	8

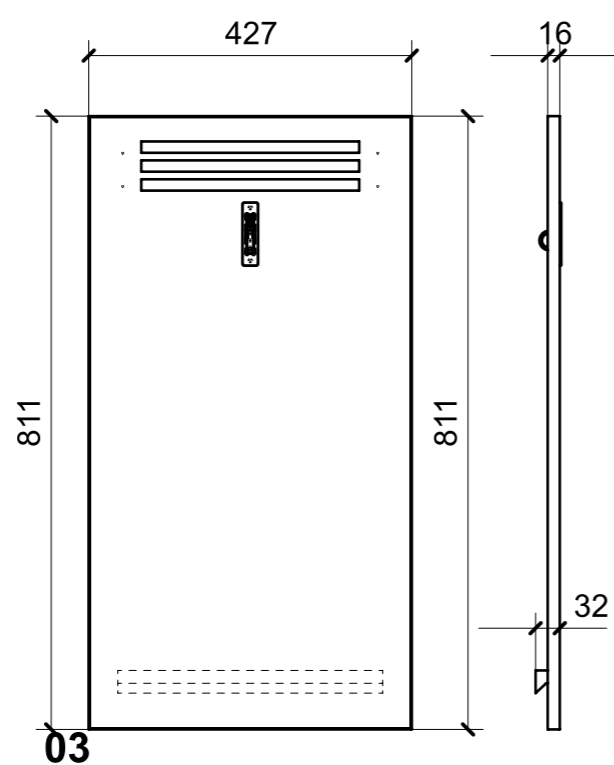
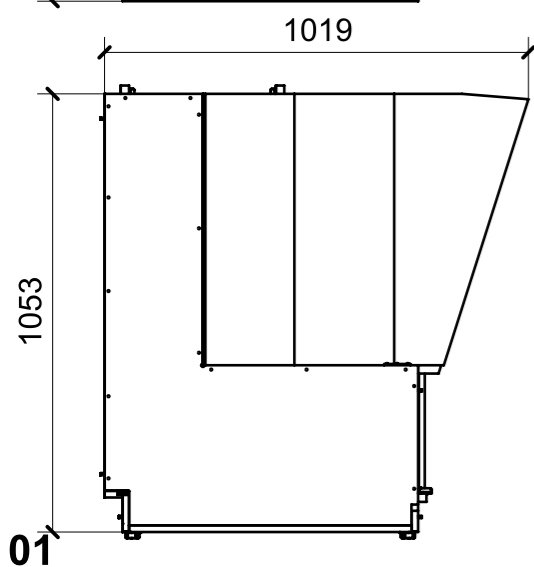
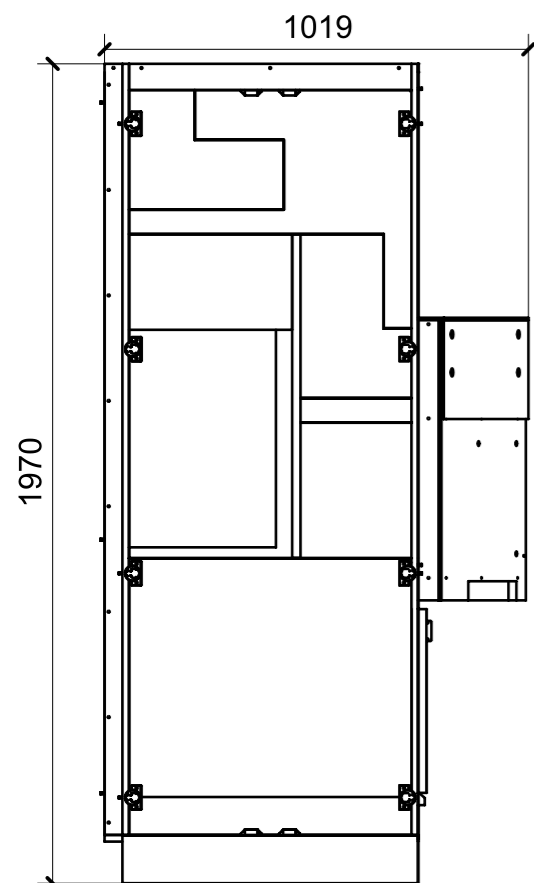

FERRAMENTA	QTY
ALZAPAGLIOLI_FORESTI_164.C	1

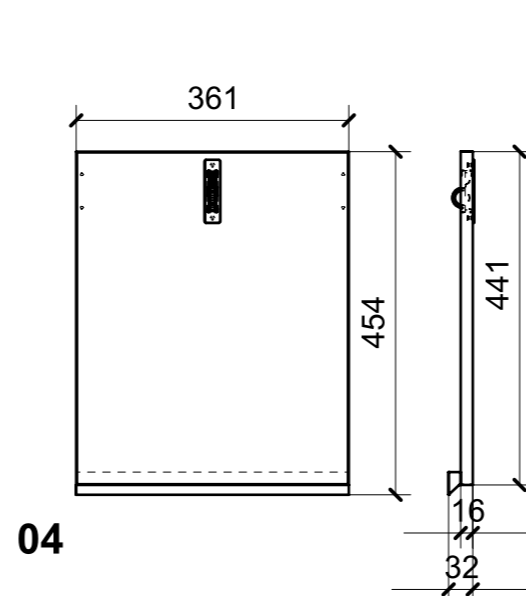

FERRAMENTA	QTY
ALZAPAGLIOLI_FORESTI_164.C	1

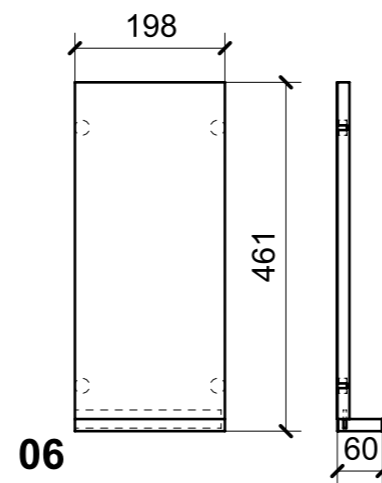
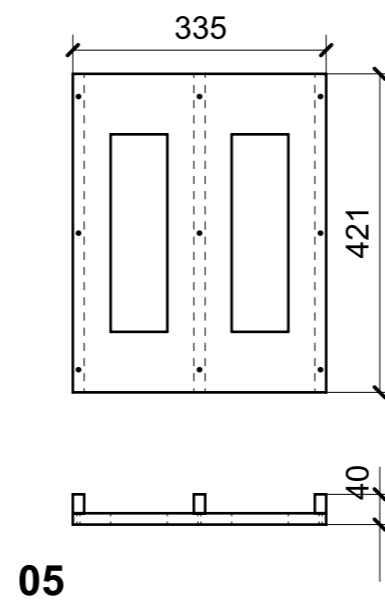
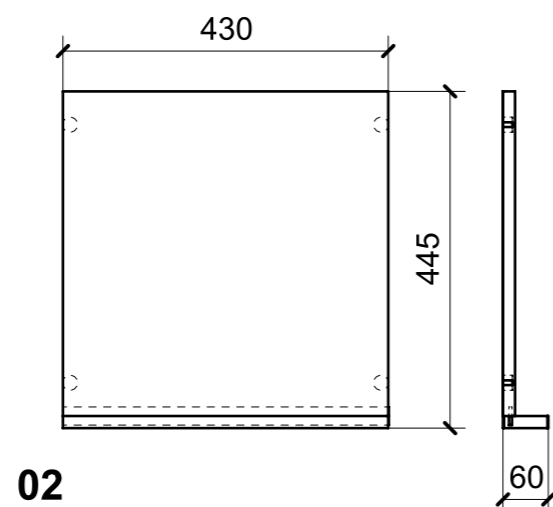

FERRAMENTA	QTY
BASE_3-NERA_HAFELE_342.22.067-BLUM_175H3130.STP	8
BUSSOLA 5MA ANKOR BORGHI	32
BUSSOLA 6MA X 10 FORO DIAM.8	5
CALAMITA SEALED MAGNETIC_TECNOPARTNER_MC-JM50-BL	4
CERNIERA 94°_PIANA-NERA_HAFELE_342.46.604-BLUM_71B9550.STP	8
CHIUSURA A SPINTA_TECNOPARTNER_SOU C3-203	4
COPERTURA BRACCIO CERNIERA NERO-HAFELE_342.94.602-BLUM_70.1503.STP	8
COPERTURA GABBIA CERNIERA NERO_HAFE_342.45.032-BLUM_70T3504.STP	8
FITLOCK F_MASCHERPA_6020101102	1
FITLOCK M_MASCHERPA_3MM_6020202101	1
VITE 4MAX8 ANKOR BORGHI	32
VITE 5MA X 25 TESTA BOMBATA	2
VITE 5MA X 25 TESTA SVASATA	5
VITE 5MA X 30 TESTA BOMBATA	4

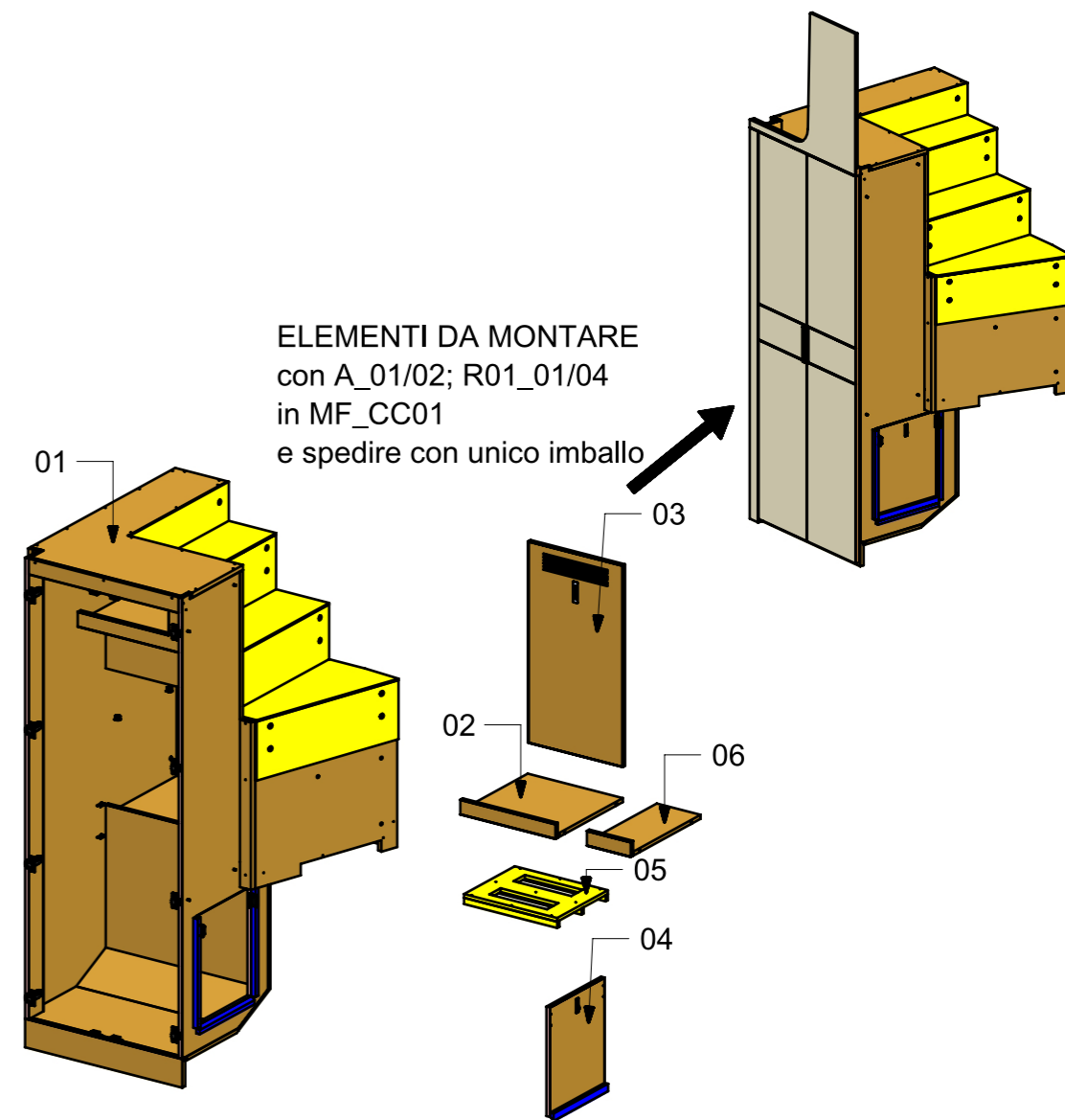

ELEMENTI DA MONTARE
con A_01/02; R01_01/04
in MF_CC01
e spedire con unico imballo

LOCALE	CODICE	DESCRIZIONE COMPONENTE	FINITURA	GR.
LOBBY	MD298_R01_CC01	ARMADIO SOTTOSCALA	LASTRA CHIARA	8

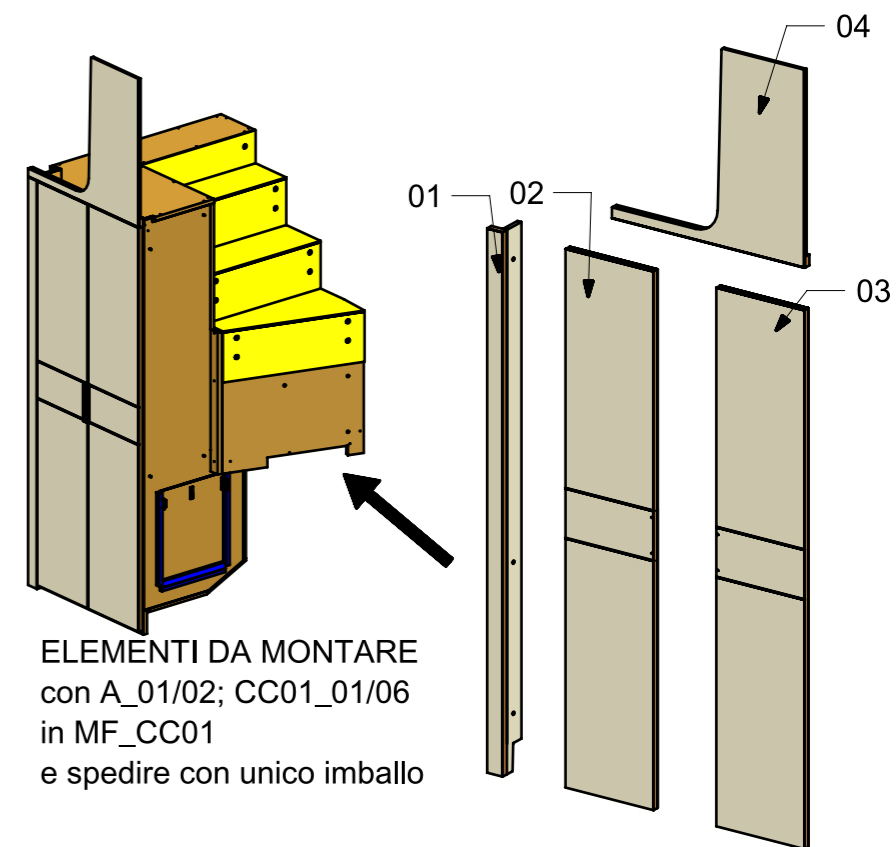
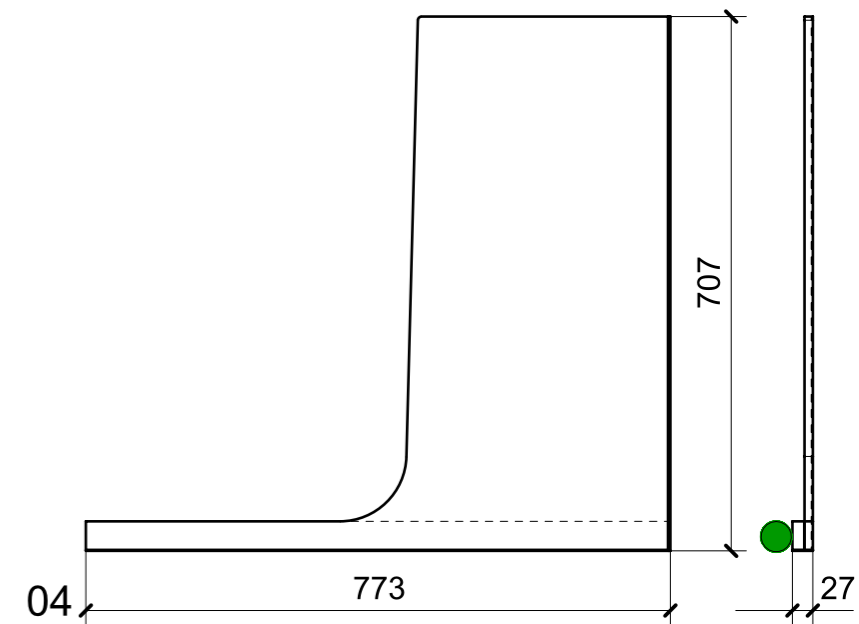
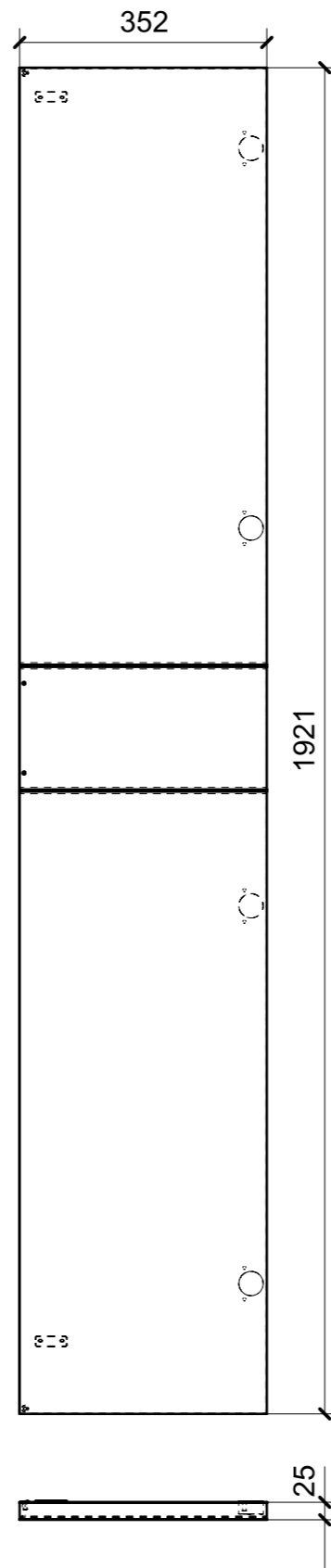
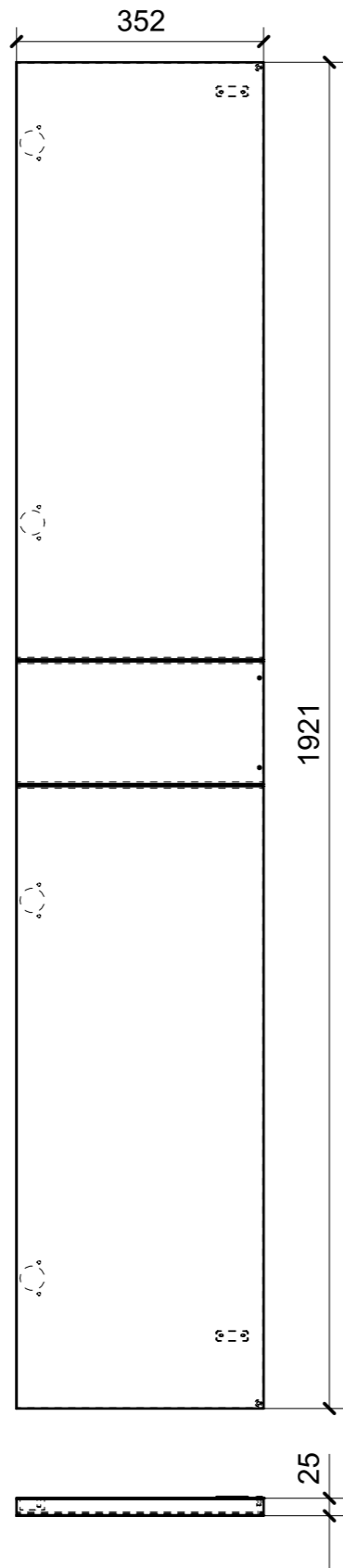
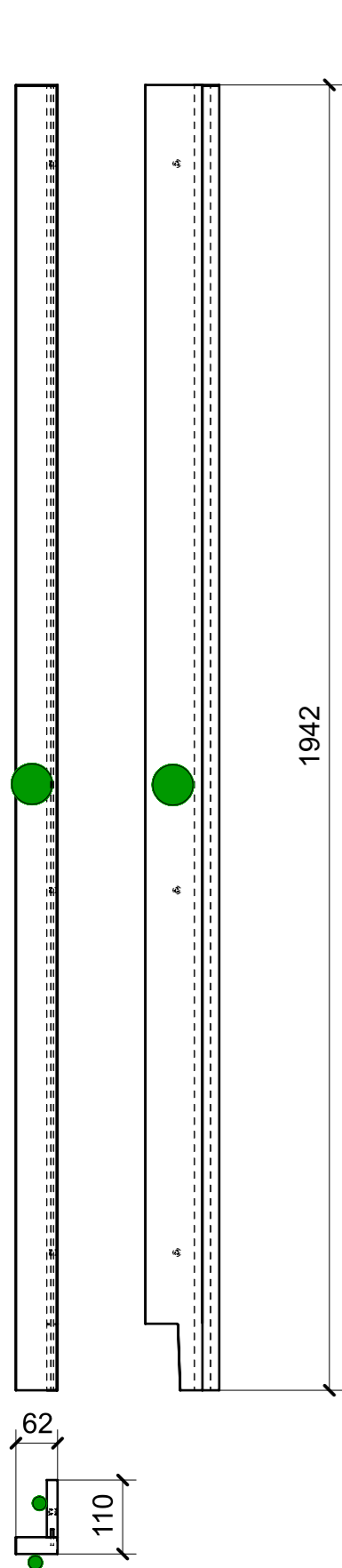

ELEMENTI DA MONTARE
con A_01/02; CC01_01/06
in MF_CC01
e spedire con unico imballo

01

FERRAMENTA	QTY
BUSSOLA 5MA X 10 FORO DIAM.8	3

FERRAMENTA	QTY
PLACCHETTA COUNTER STEEL_TECHNOPARTNER_MC-JM49	2
GOMMINO PARACOLPO ANTA	2

03

FERRAMENTA	QTY
GOMMINO PARACOLPO ANTA	2
PLACCHETTA COUNTER STEEL_TECHNOPARTNER_MC-JM49	2

VERNICIATURA LASTRA/LACCATI:

● = VERNICIARE 1 LATO + FILI RASATI O BORDATI

NESSUN SIMBOLO = VERNICIARE 2 LATI + FILI RASATI O BORDATI

LOCALE	CODICE	DESCRIZIONE COMPONENTE	FINITURA	GR.
LOBBY	MD298_A01_CC01	ARMADIO SOTTOSCALA	MANIGLIA PAMAR VERN.serie 90MFY-01.02	8

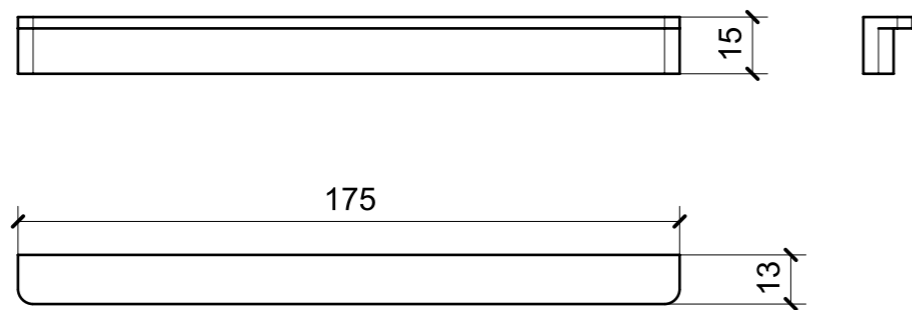

A_CC01_01

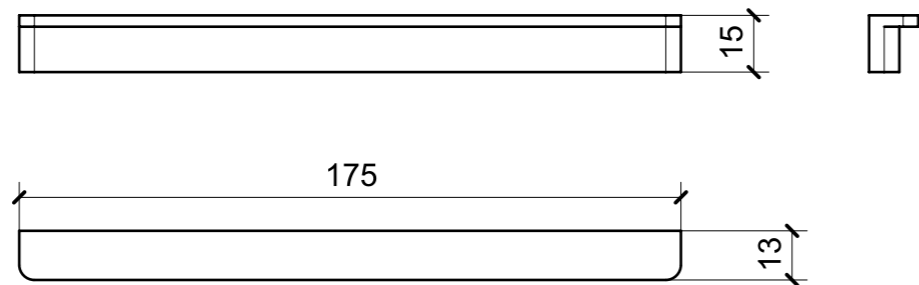

A_CC01_02

ELEMENTI DA MONTARE
 con R01_01/04; CC01_01/06
 in MF_CC01
 e spedire con unico imballo

