

LOCALE	CODICE	DESCRIZIONE COMPONENTE	FINITURA	GR
FRONTE MARCIA	MD298_MG_FD01	MOBILE QUADRI ELETTRICI	LACCATO SIMIL CAMPIONE PELLE M2553 RAL.	5

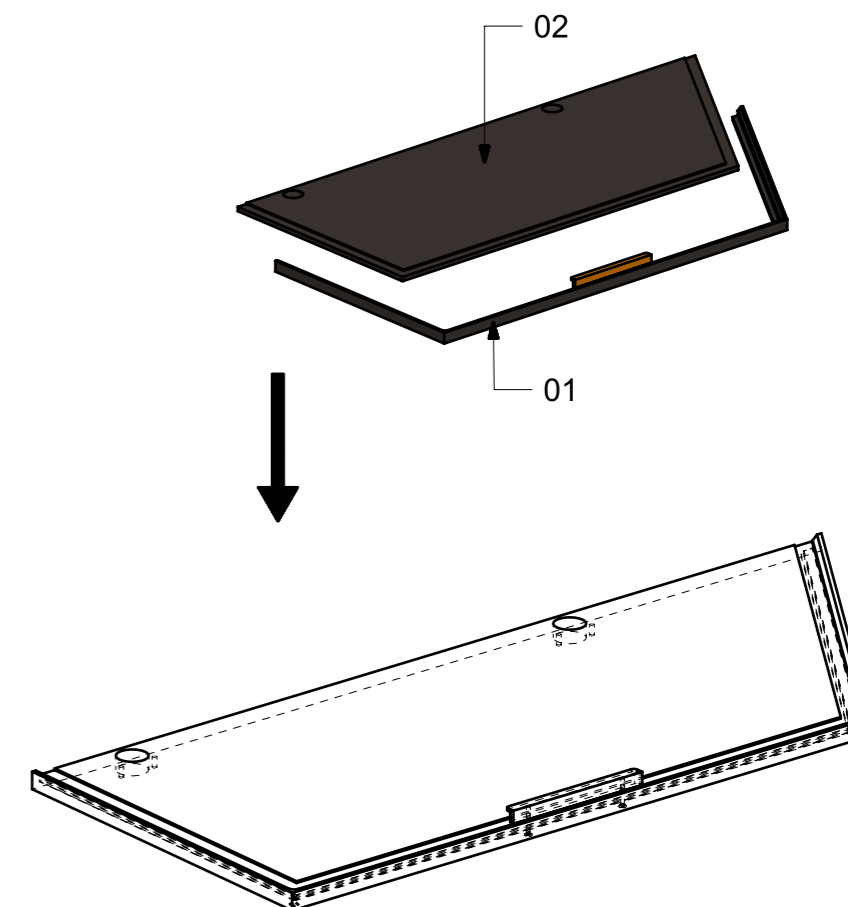
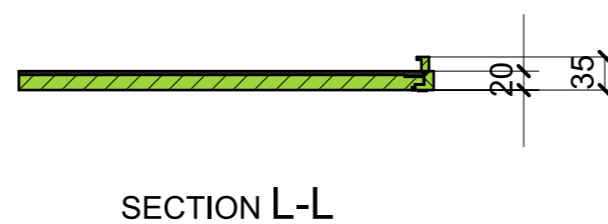
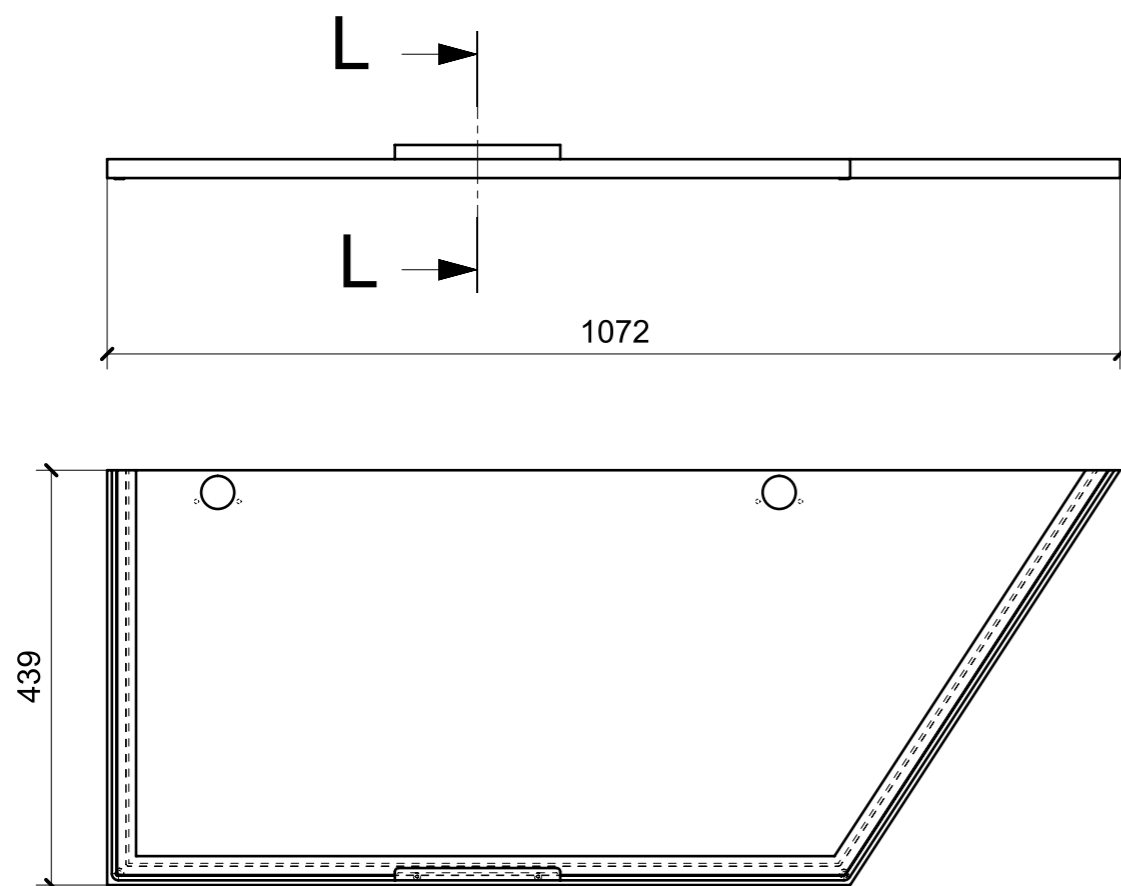

FERRAMENTA	QTY
MANIGLIA X MOBILE PAMAR_FBC BORGHI_886Z-175 ALOP	1
VITE 4MA X 25 TESTA SVASATA ESAGONALE NERA	2
GOMMINO PARACOLPO ANTA	2