

LOCALE	CODICE	DESCRIZIONE COMPONENTE	FINITURA	Q.TA
CABINA ARMATORE	MD298_R01_AA01	STRUTTURA MURATA DX	LASTRA CHIARA	1

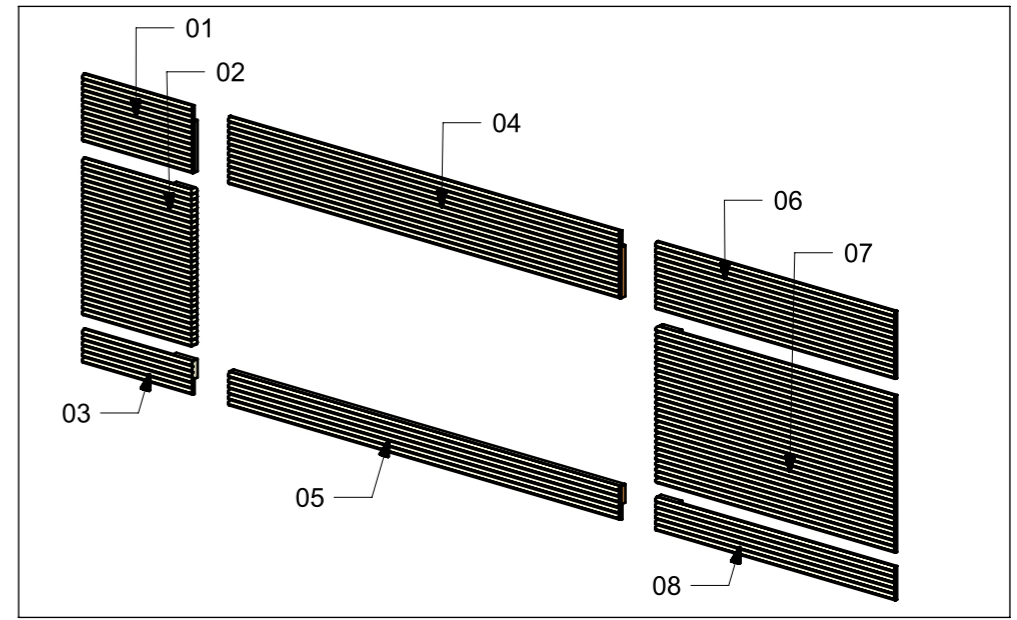
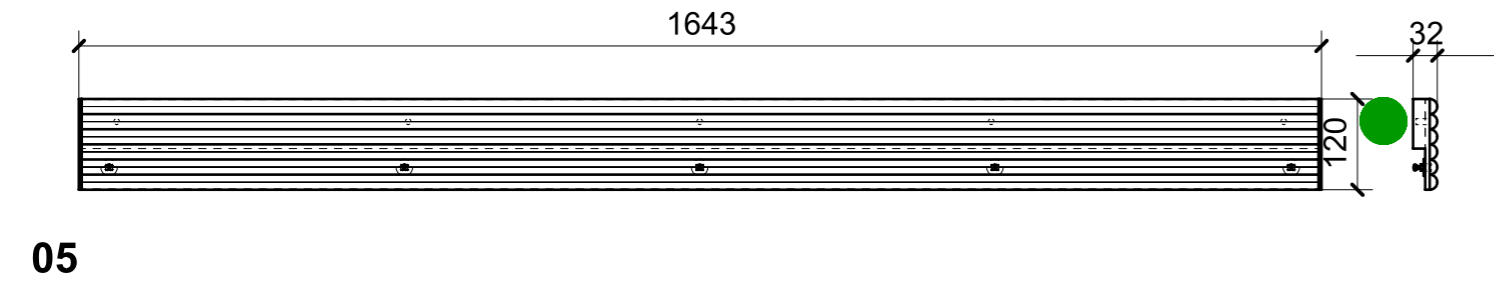
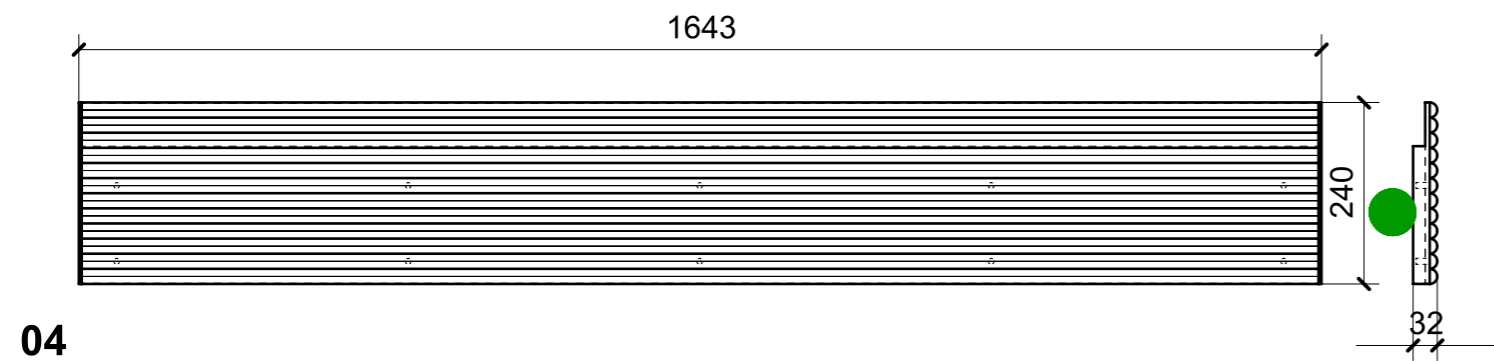
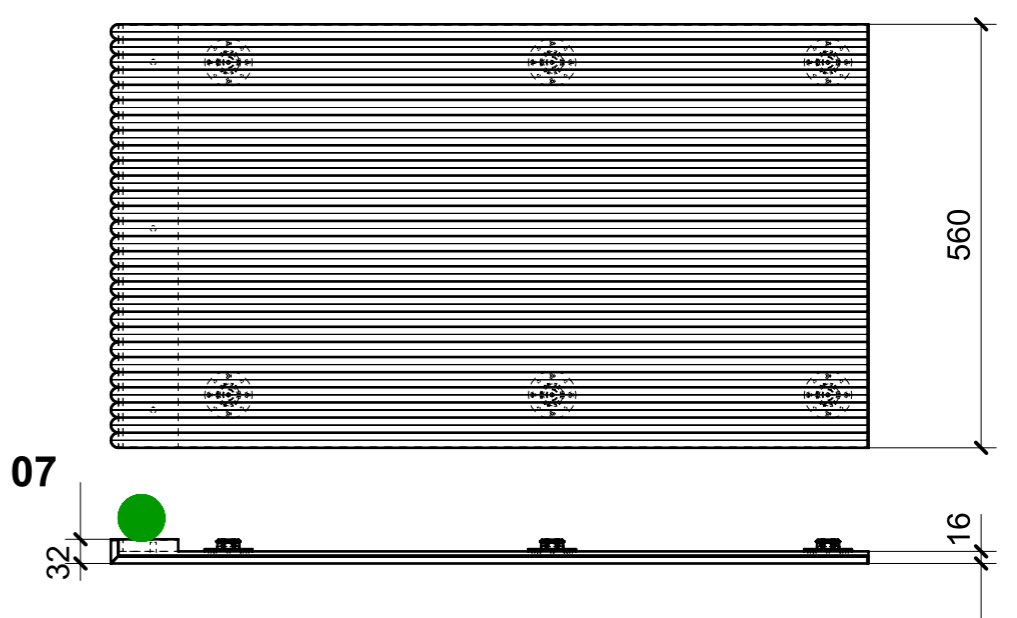
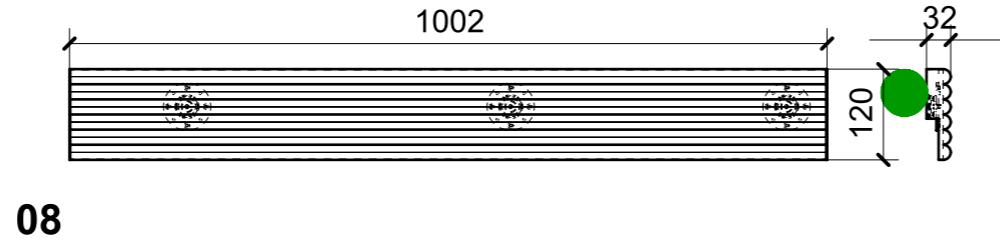
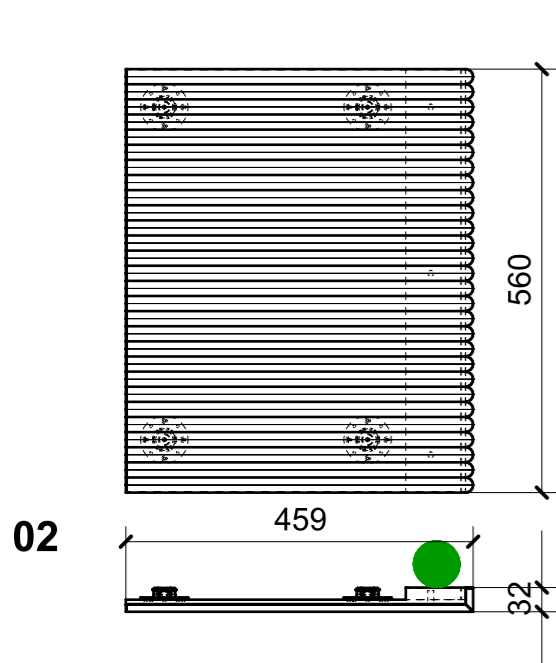
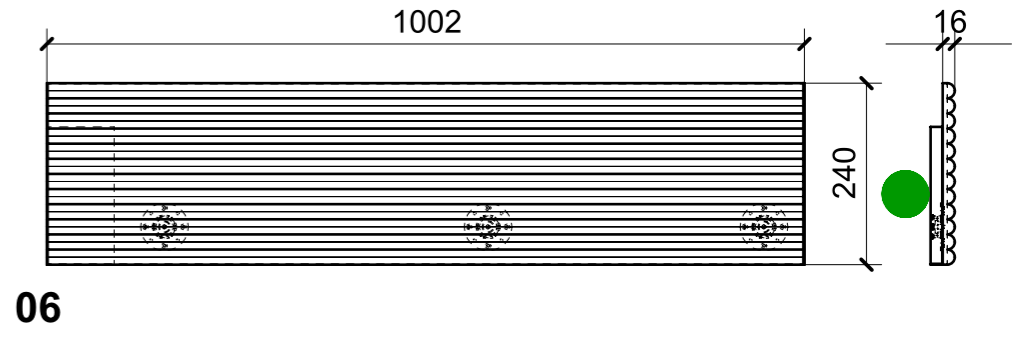
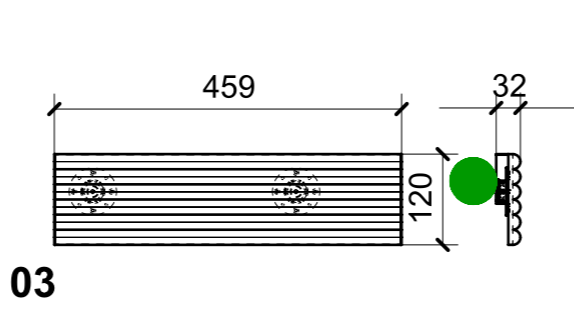
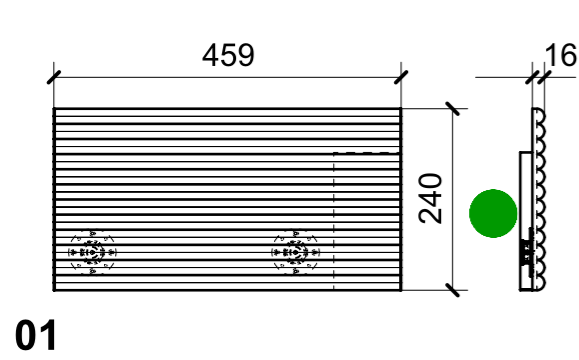

FERRAMENTA	QTY
MS INCASSO_ITALVIPLA_972_FMPC_M1B	5
FITLOCK M_MASCHERPA_3MM_6020202101	20

VERNICIATURA LASTRA/LACCATI:
 ● = VERNICIARE 1 LATO + FILI RASATI O BORDATI NESSUN SIMBOLO = VERNICIARE 2 LATI + FILI RASATI O BORDATI

LOCALE	CODICE	DESCRIZIONE COMPONENTE	FINITURA	Q.TA
CABINA ARMATORE	MD298_R01_AE01	STRUTTURA MURATA SX	LASTRA CHIARA	1

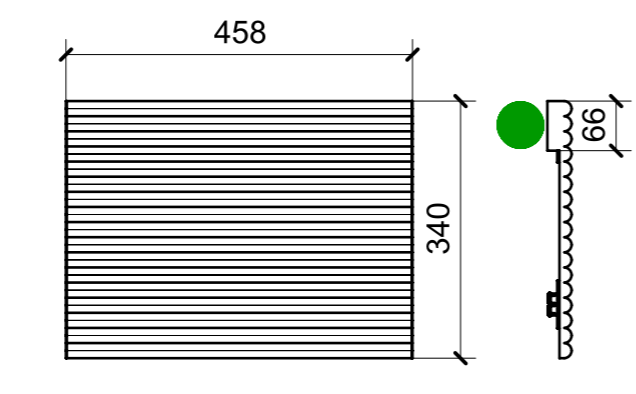
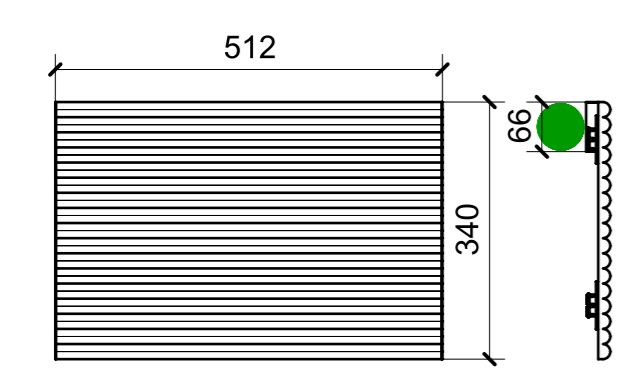
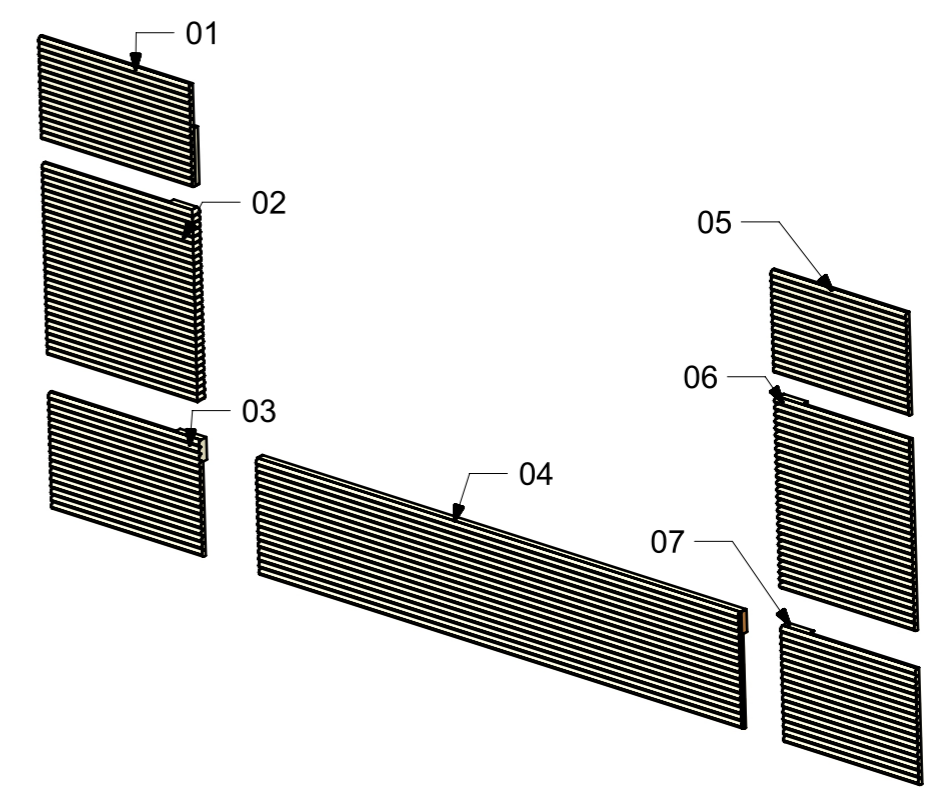
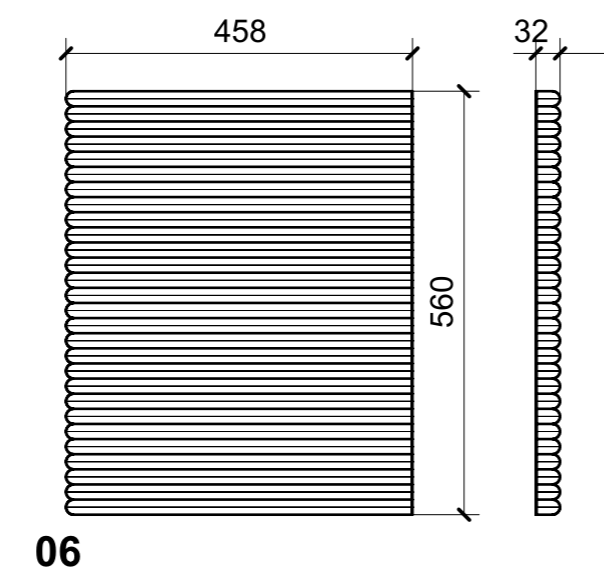
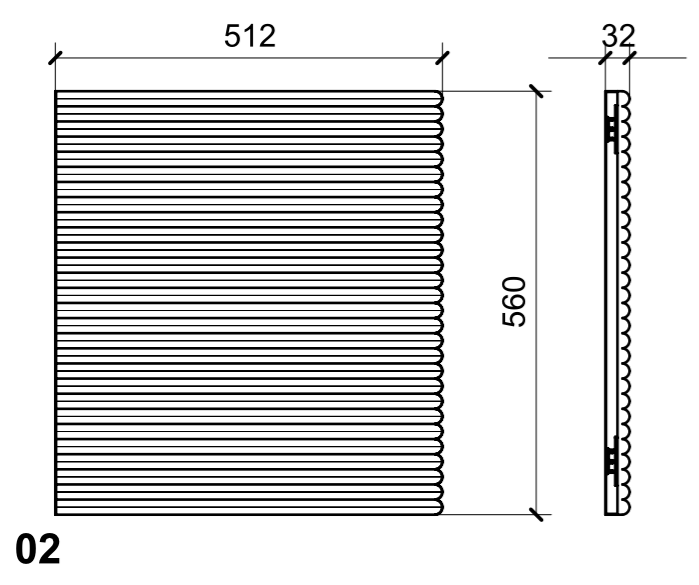
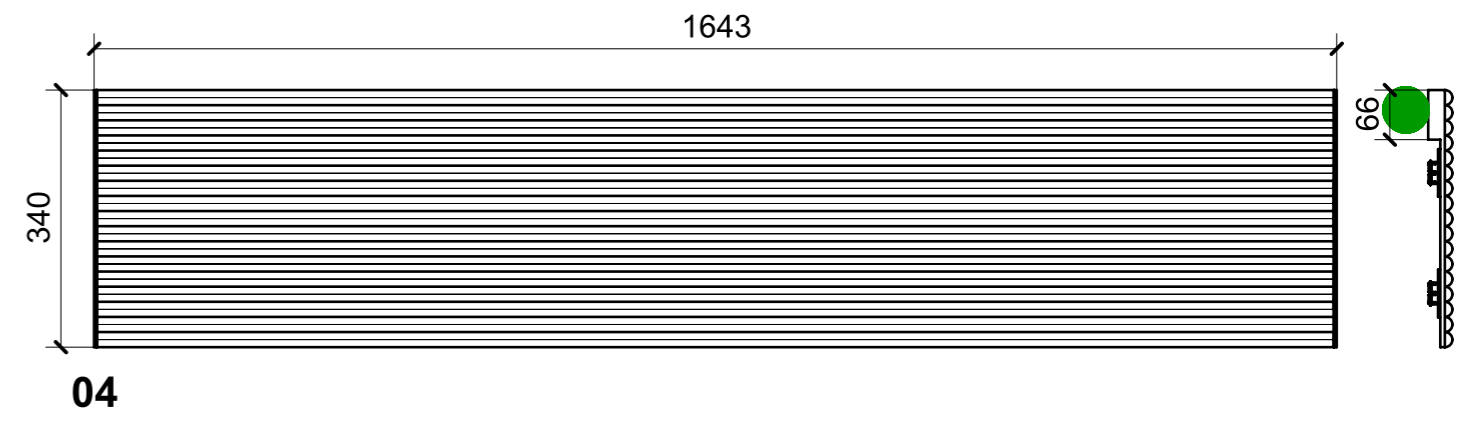
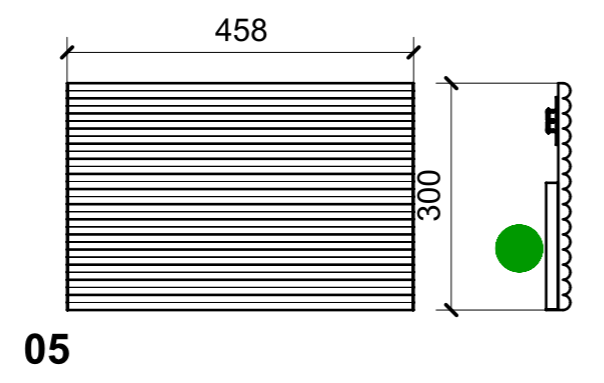
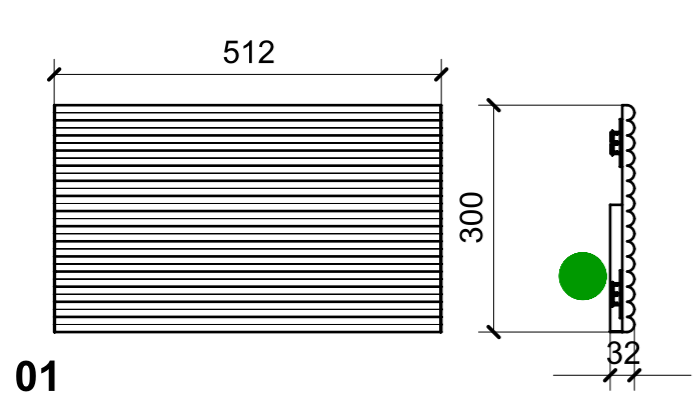

FERRAMENTA	QTY
FITLOCK M_MASCHERPA_3MM_6020202101	32

VERNICIATURA LASTRA/LACCATI:
 ● = VERNICIARE 1 LATO + FILI RASATI O BORDATI NESSUN SIMBOLO = VERNICIARE 2 LATI + FILI RASATI O BORDATI

LOCALE	CODICE	DESCRIZIONE COMPONENTE	FINITURA	Q.TA
CABINA ARMATORE	MD298_R01_AF01	STRUTTURA A PONTE MURATA SX	LASTRA CHIARA	1

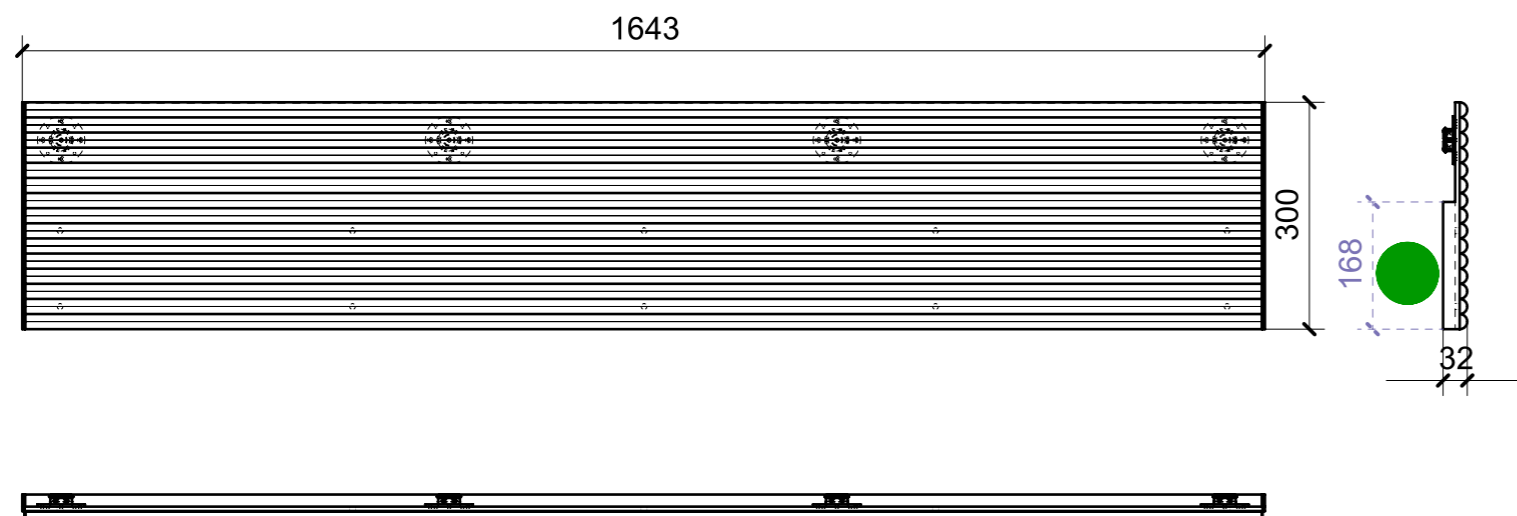

01

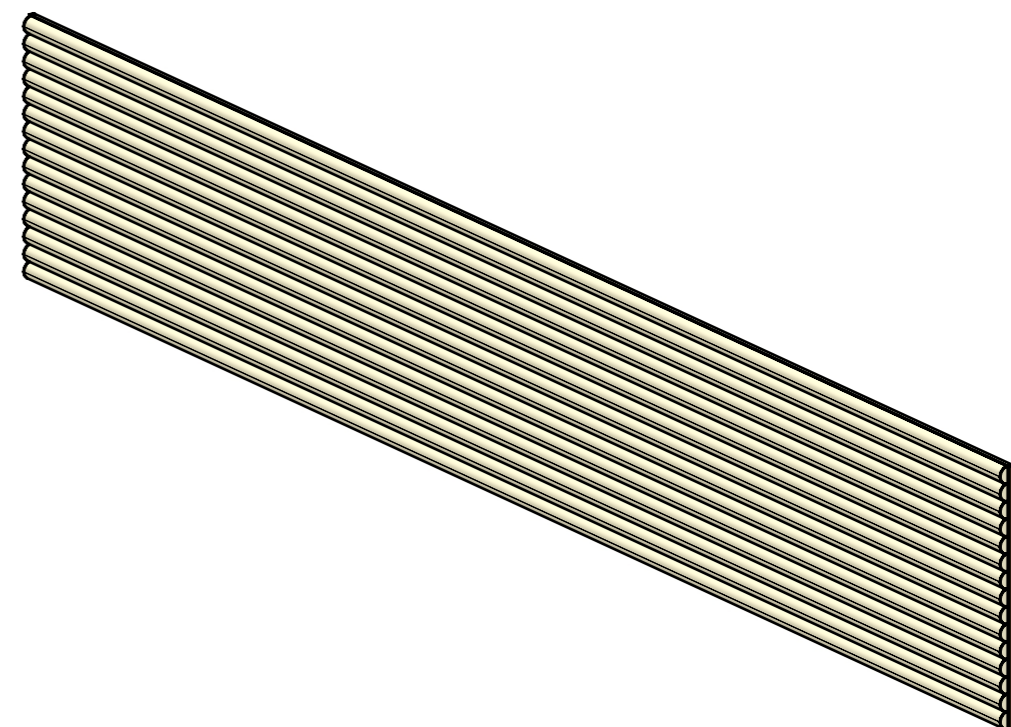

FERRAMENTA	QTY
FITLOCK M_MASCHERPA_3MM_6020202101	4

VERNICIATURA LASTRA/LACCATI:

● = VERNICIARE 1 LATO + FILI RASATI O BORDATI

NESSUN SIMBOLO = VERNICIARE 2 LATI + FILI RASATI O BORDATI

LOCALE	CODICE	DESCRIZIONE COMPONENTE	FINITURA	GR.
CABINA ARMATORE	MD298_R01_AI01	COMODINO PRODIERO	LASTRA CHIARA	06

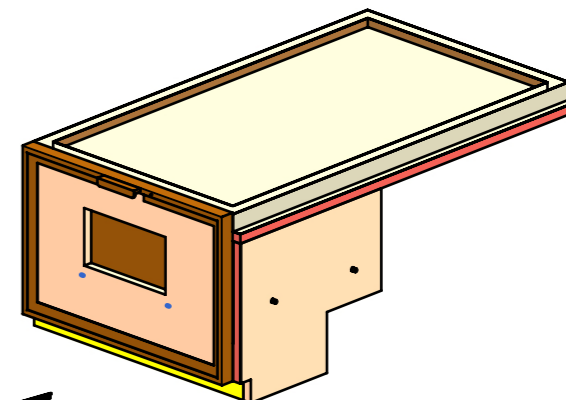
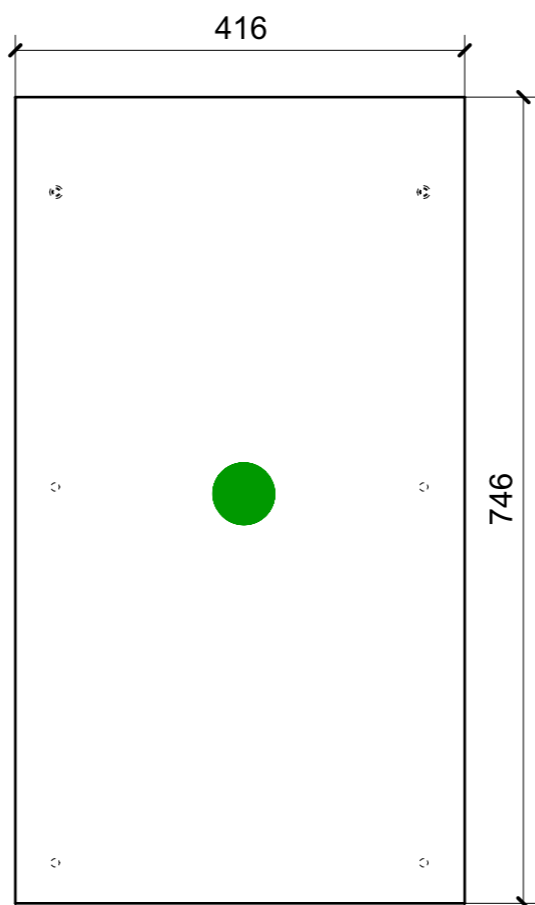
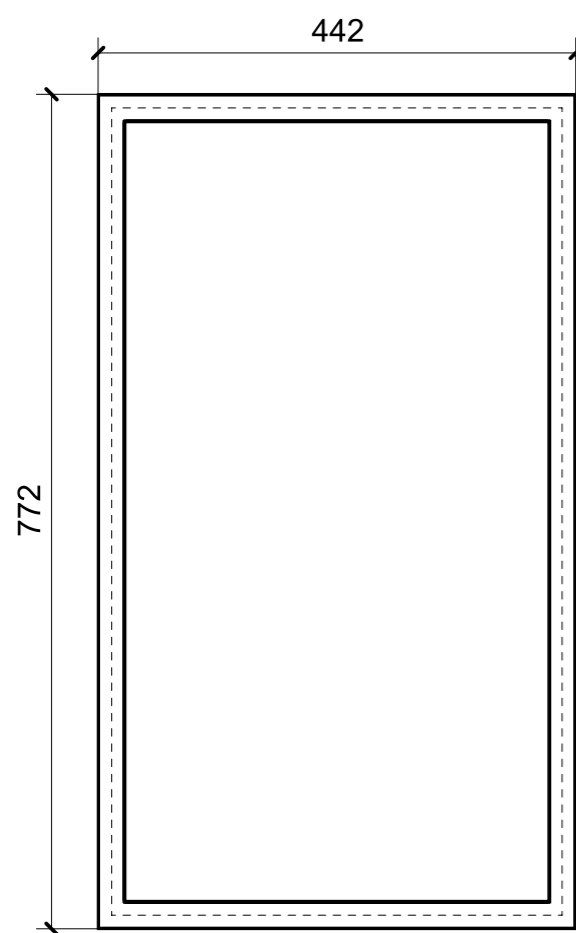
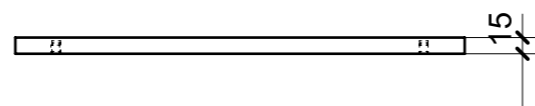
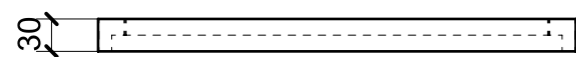

ELEMENTI DA MONTARE
 con AI_01/02; X01_AI01_01-->07
 A01_AI_13/14 in MF_AI01
 e spedire con unico imballo

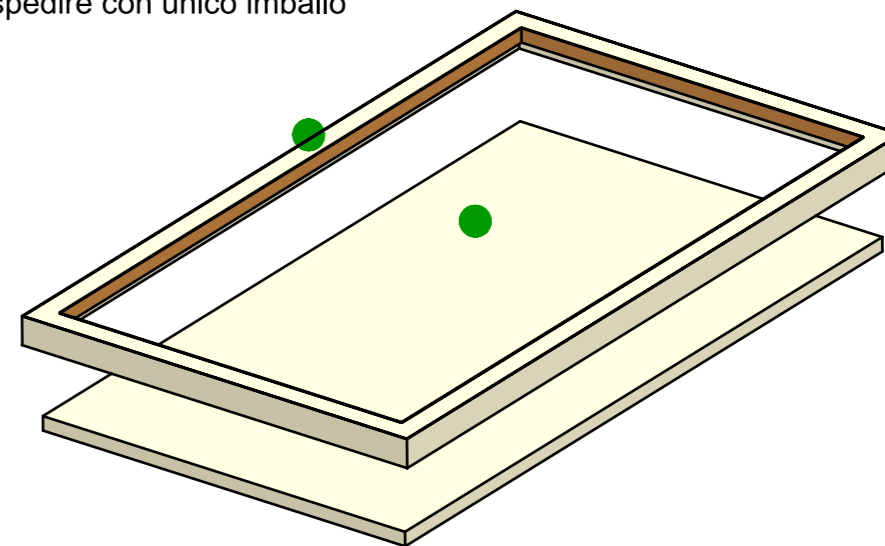

01

02

VERNICIATURA LASTRA/LACCATI:

● = VERNICIARE 1 LATO + FILI RASATI O BORDATI

NESSUN SIMBOLO = VERNICIARE 2 LATI + FILI RASATI O BORDATI

LOCALE	CODICE	DESCRIZIONE COMPONENTE	FINITURA	GR.
CABINA ARMATORE	MD298_R01_AL01	COMODINO POPPIERO	LASTRA CHIARA	06

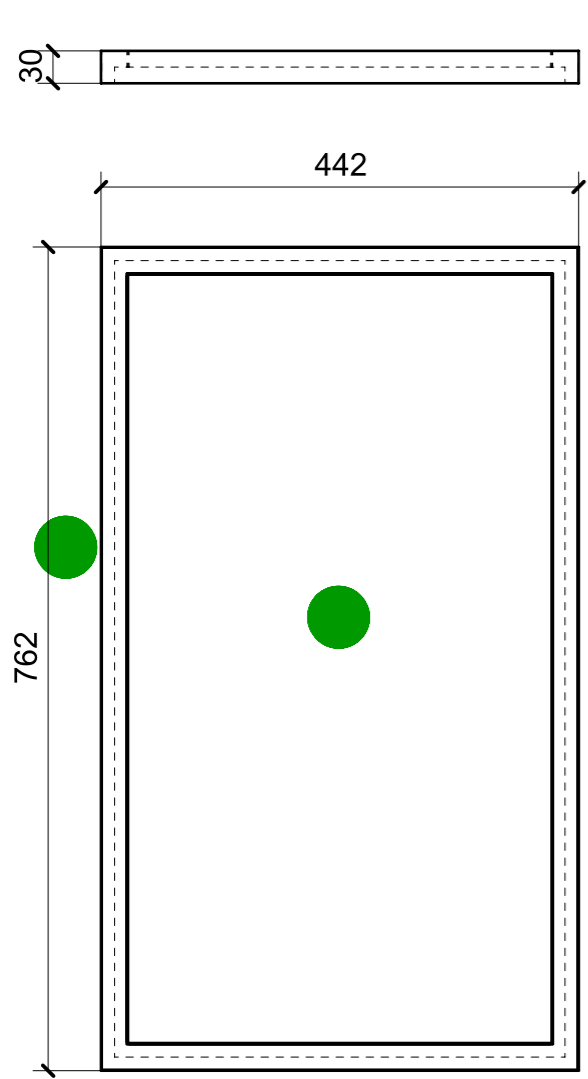

01

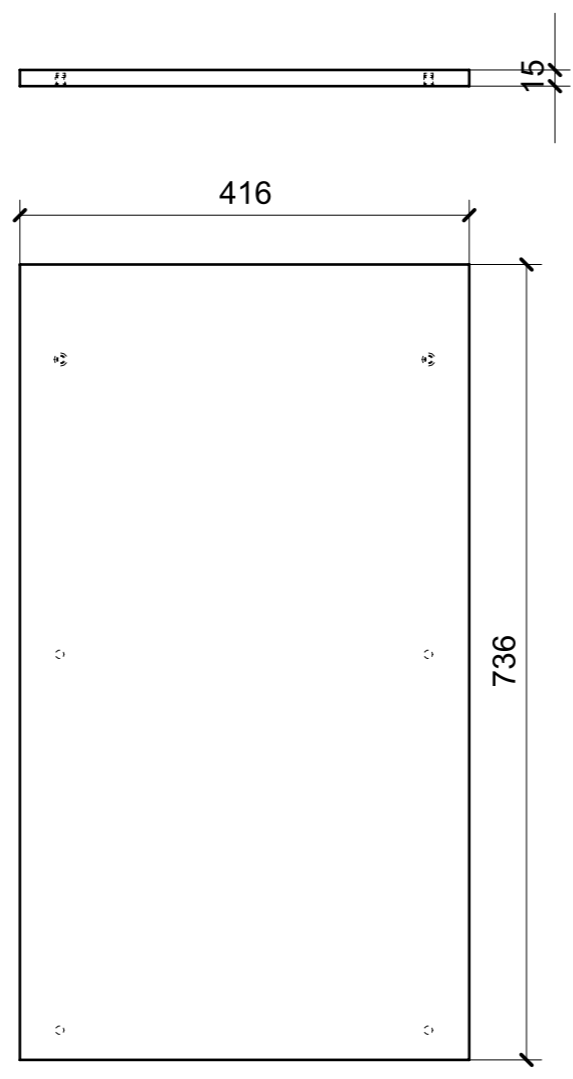

02

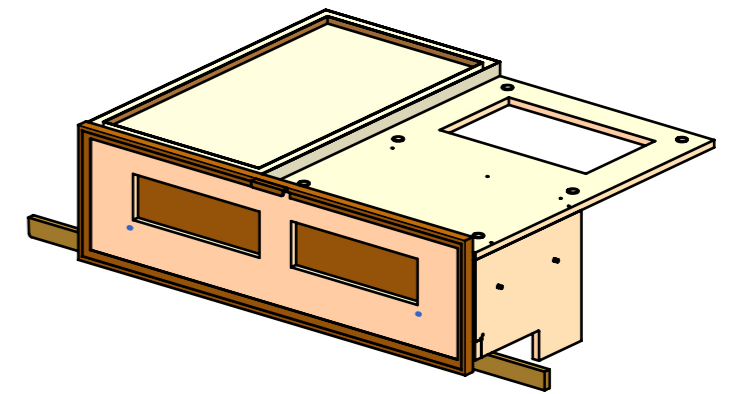

ELEMENTI DA MONTARE
 con AL01_01; X01_AL01_01; A15-A16
 in MF_AL01
 e spedire con unico imballo

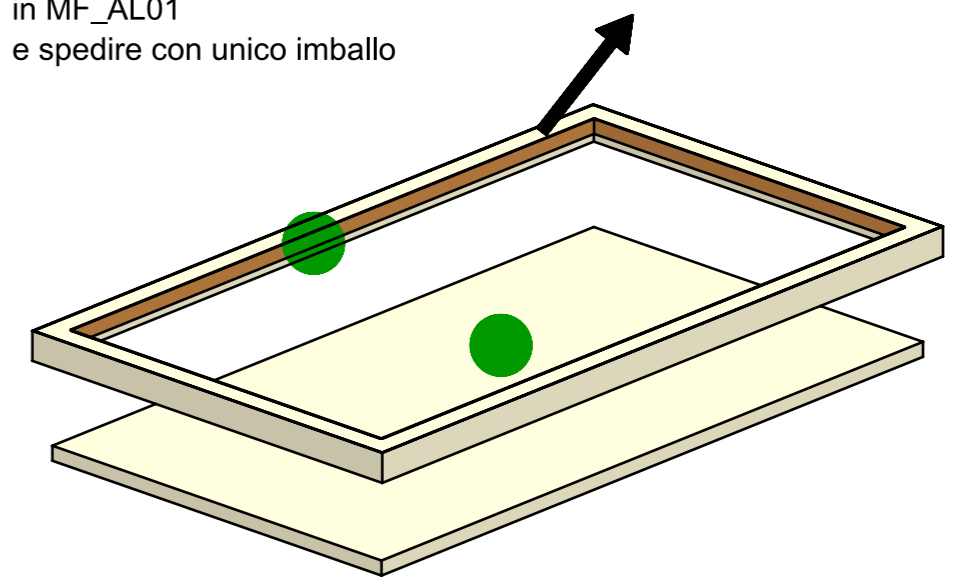

VERNICIATURA LASTRA/LACCATI:
 ● = VERNICIARE 1 LATO + FILI RASATI O BORDATI NESSUN SIMBOLO = VERNICIARE 2 LATI + FILI RASATI O BORDATI

LOCALE	CODICE	DESCRIZIONE COMPONENTE	FINITURA
CABINA ARMATORE	MD298_R01_AM01	MOBILE POPPIERO MURATA SX	LASTRA CHIARA

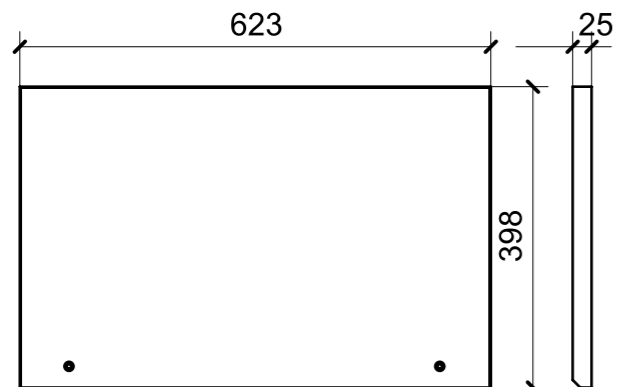

01

FERRAMENTA	QTY
BUSSOLA 6MA X 10 FORO DIAM.8	2

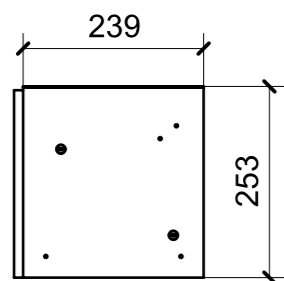
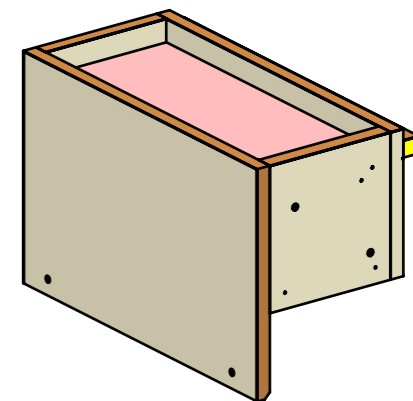

02

FERRAMENTA	QTY
VITE 5MA X 35 TESTA BOMBATA	2

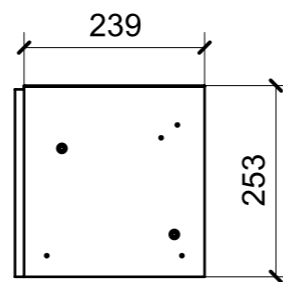

04

FERRAMENTA	QTY
BUSSOLA 5MA X 10 FORO DIAM.8	2

ELEMENTI DA MONTARE
con L01_AM01_01/02 in MF_AM01
e spedire con unico imballo

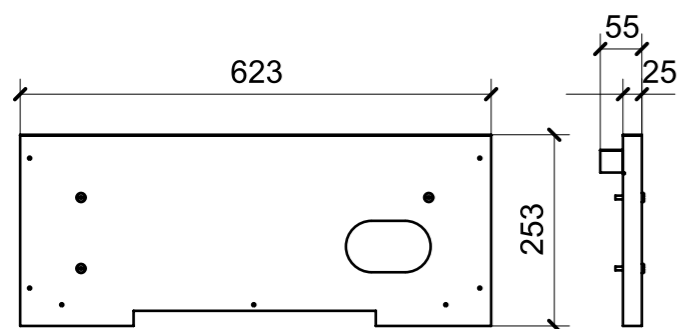
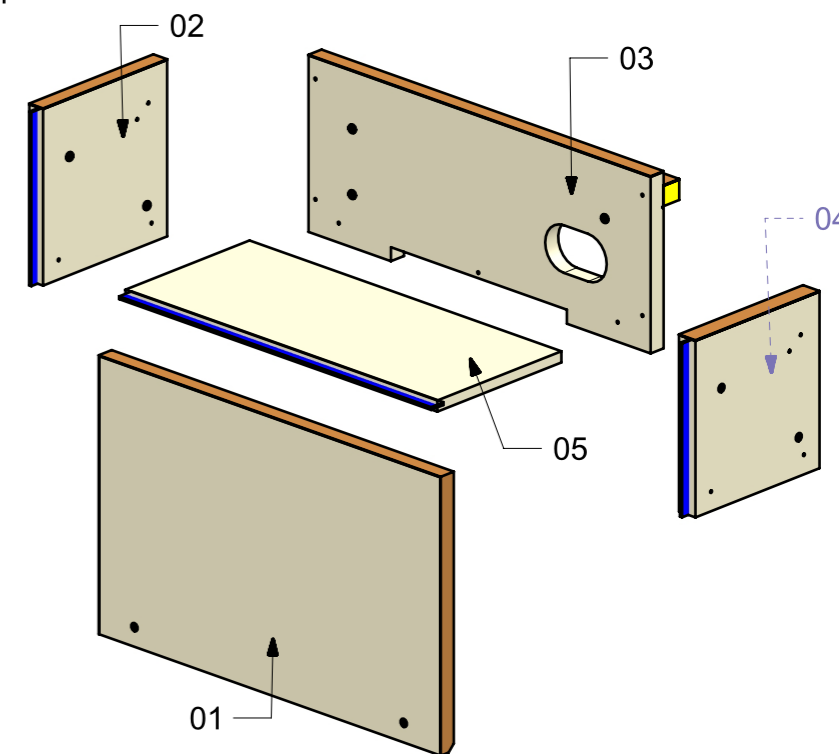

03

FERRAMENTA	QTY
VITE 5MA X 35 TESTA BOMBATA	3

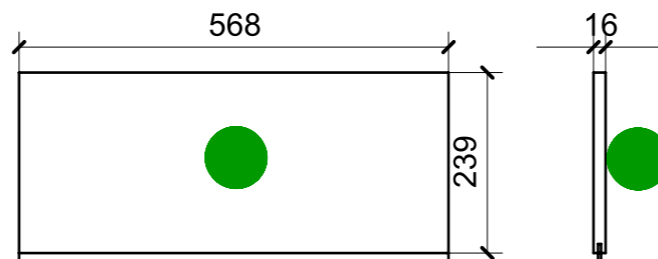

05

VERNICIATURA LASTRA/LACCATI:

● = VERNICIARE 1 LATO + FILI RASATI O BORDATI

NESSUN SIMBOLO = VERNICIARE 2 LATI + FILI RASATI O BORDATI

LOCALE	CODICE	DESCRIZIONE COMPONENTE	FINITURA
CABINA ARMATORE	MD298_R01_AN01	MOBILE CENTRALE MURATA SX	LASTRA CHIARA

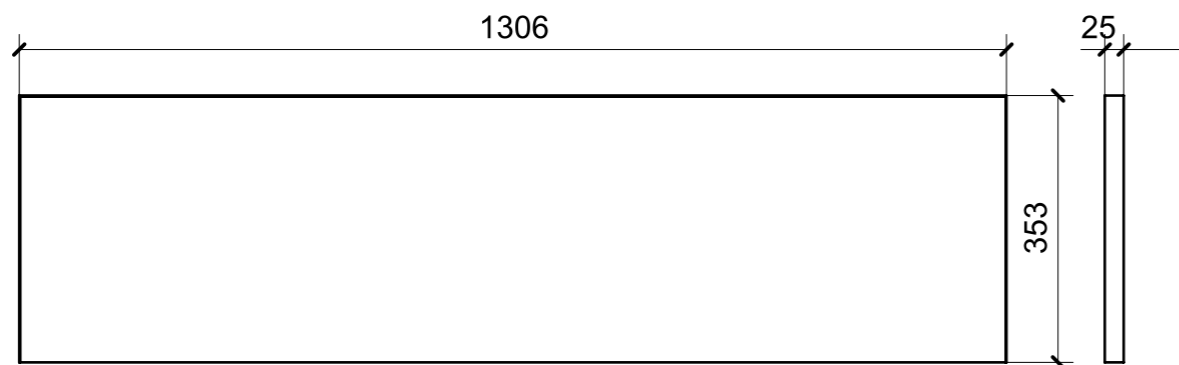

01

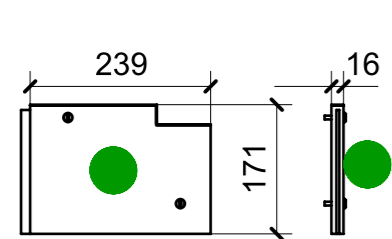

02

FERRAMENTA	QTY
VITE 5MA X 25 TESTA BOMBATA	2

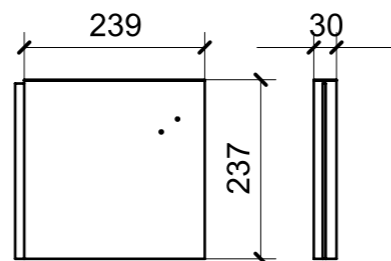

04

FERRAMENTA	QTY
VITE 5MA X 25 TESTA BOMBATA	2

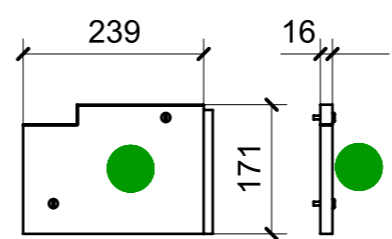

05

FERRAMENTA	QTY
VITE 5MA X 25 TESTA BOMBATA	2

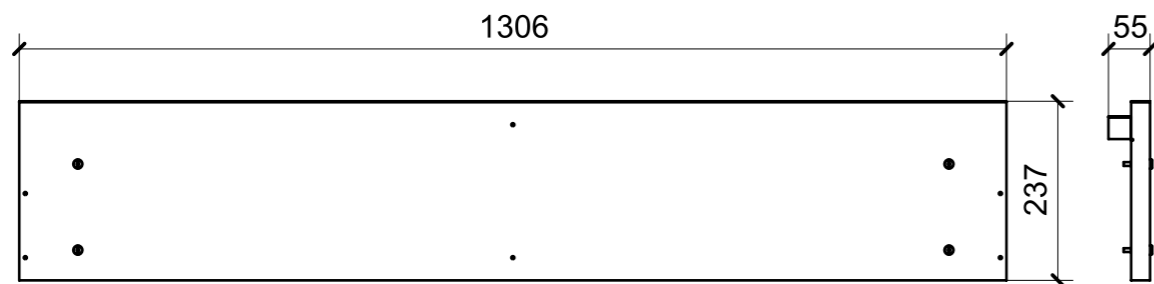

03

FERRAMENTA	QTY
VITE 5MA X 35 TESTA BOMBATA	4

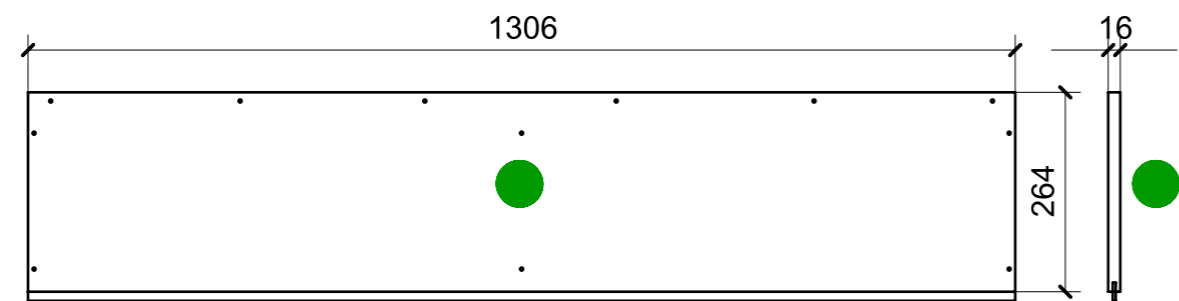

06

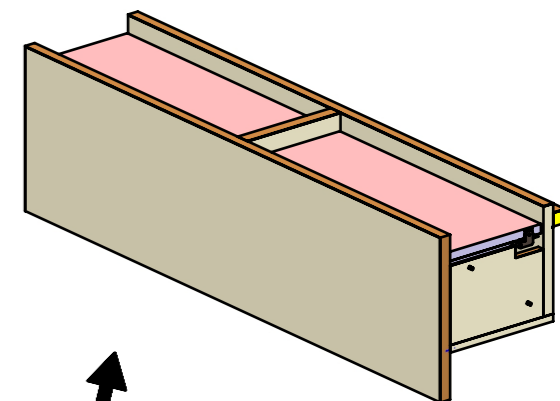

ELEMENTI DA MONTARE
con L01_AN01_01/04 in MF_AN01
e spedire con unico imballo

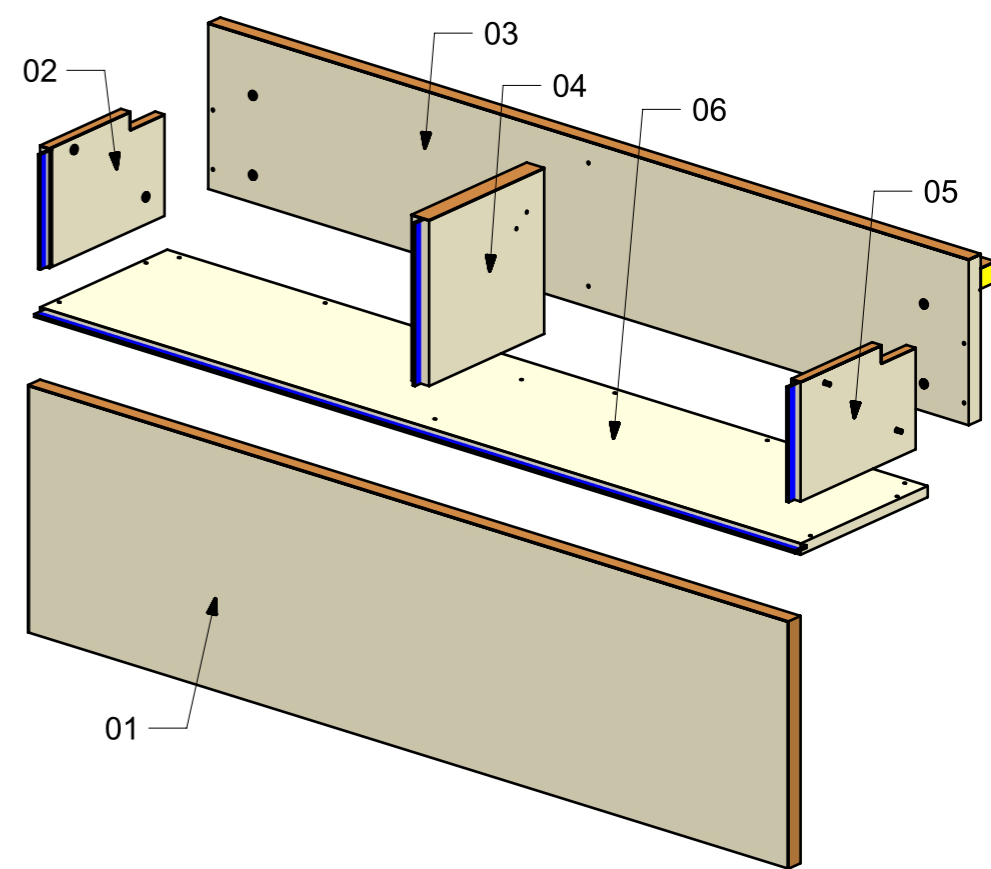

VERNICIATURA LASTRA/LACCATI:

● = VERNICIARE 1 LATO + FILI RASATI O BORDATI

NESSUN SIMBOLO = VERNICIARE 2 LATI + FILI RASATI O BORDATI

LOCALE	CODICE	DESCRIZIONE COMPONENTE	FINITURA	GR
CABINA ARMATORE	MD298_R01_AO01	MOBILE PRODIERO MURATA SX	LASTRA CHIARA	8

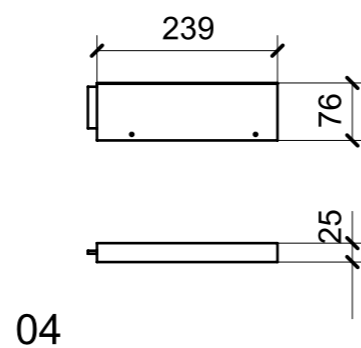
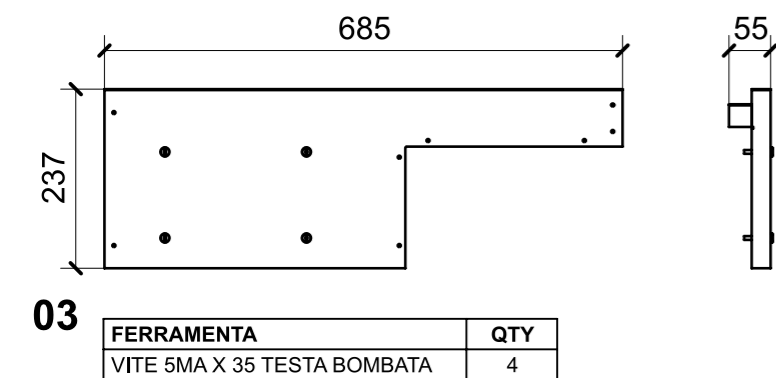
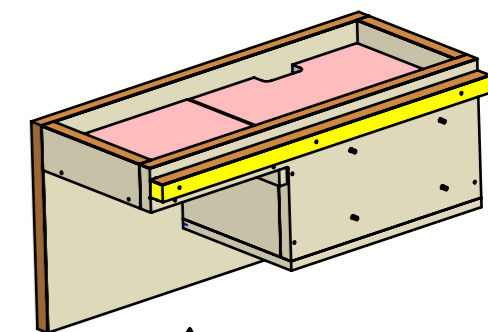
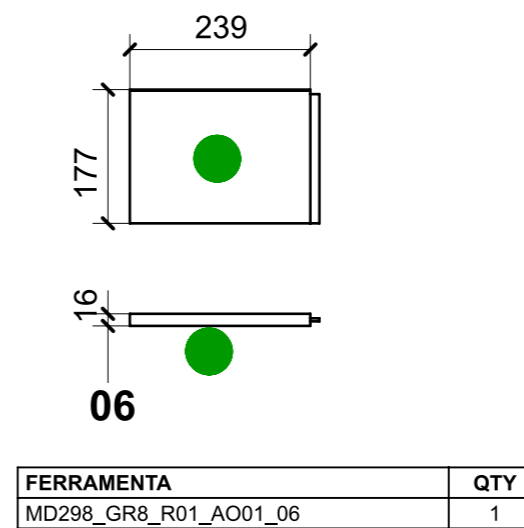
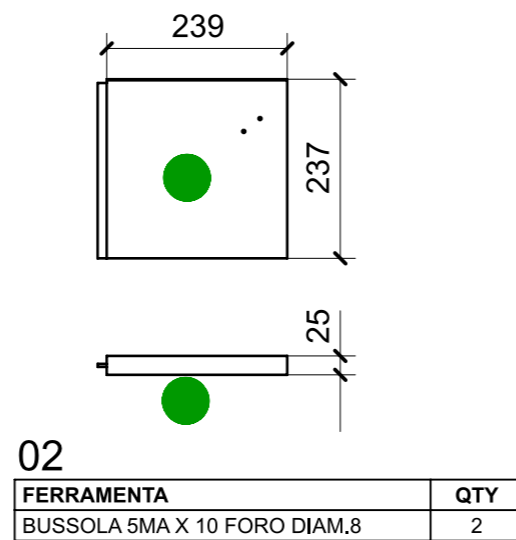
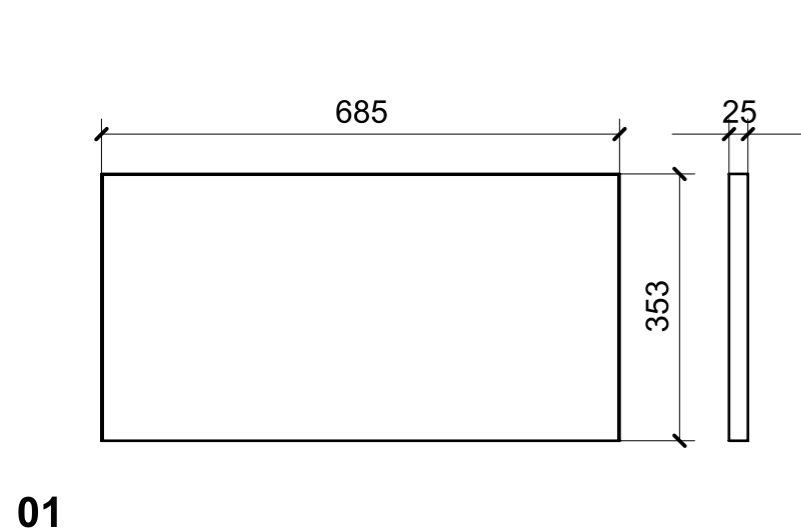

ELEMENTI DA MONTARE
con L01_AO01_01/03 in MF_AO01
e spedire con unico imballo

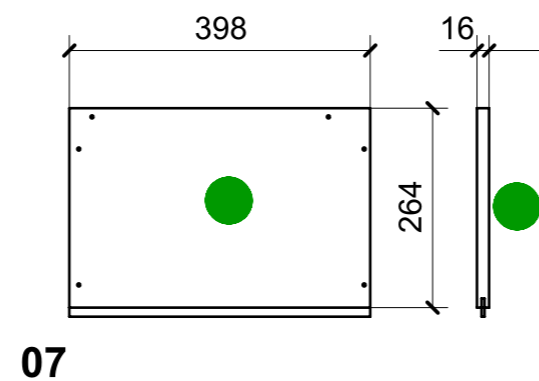
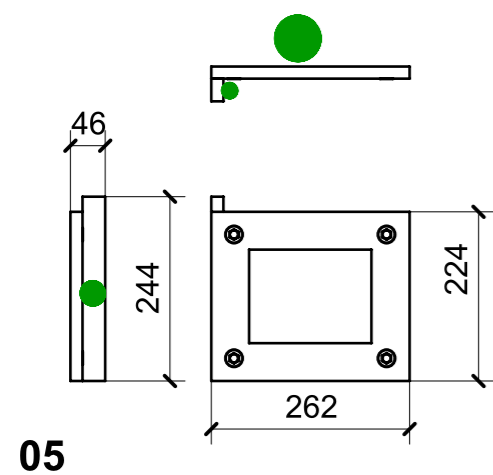
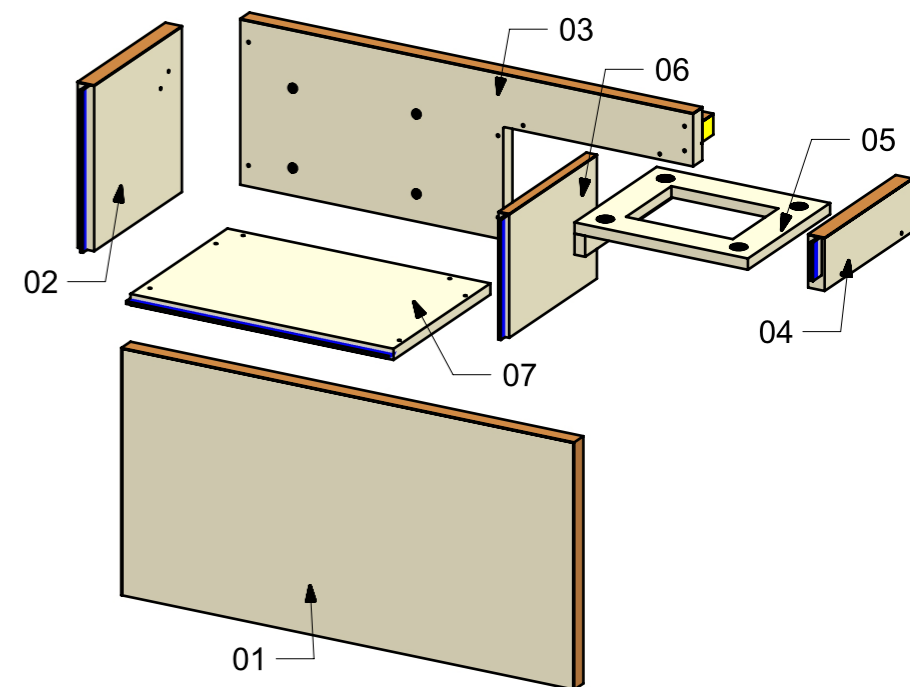

FERRAMENTA	QTY
FM INCASSO_ITALVIPLA_973_FMPC_F1A	4

VERNICIATURA LASTRA/LACCATI:

● = VERNICIARE 1 LATO + FILI RASATI O BORDATI

NESSUN SIMBOLO = VERNICIARE 2 LATI + FILI RASATI O BORDATI

LOCALE	CODICE	DESCRIZIONE COMPONENTE	FINITURA	GR
CABINA ARMATORE	MD298_R01_AP01	COMODINO LATO DIVANO_Var.1	LASTRA CHIARA	8

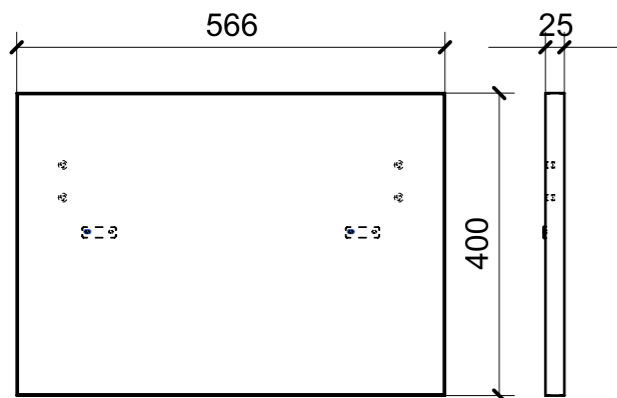

01

FERRAMENTA	QTY
BUSSOLA 5MA X 10 FORO DIAM.8	4
PLACCHETTA COUNTER STEEL_TECHNOPARTNER_MC-JM49	2

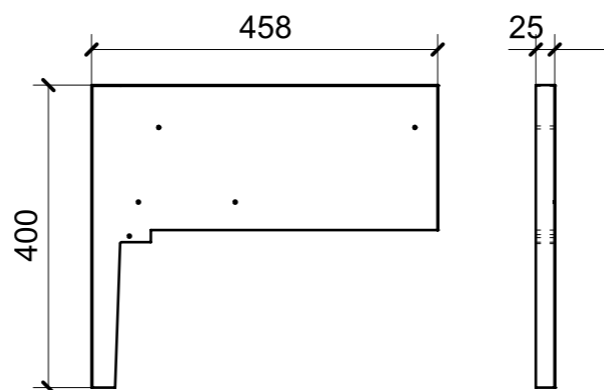

02

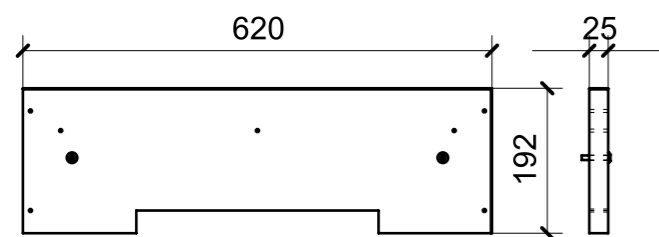
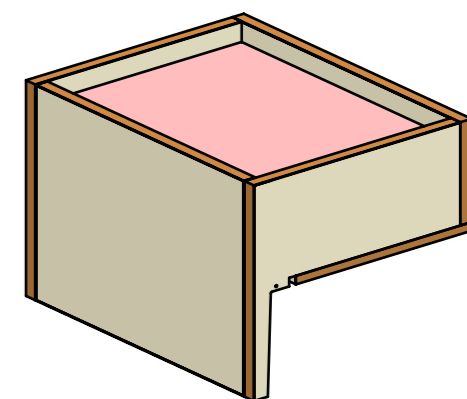

03

FERRAMENTA	QTY
VITE 6MA X 35 TESTA BOMBATA	2

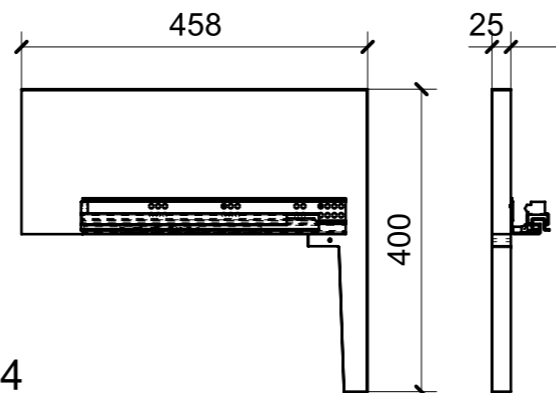

04

FERRAMENTA	QTY
CP GUIDA TANDEPLUS 350_HAFELE_423_54_735_ESSEPI_00175869	1

ELEMENTI DA MONTARE
con L01_AP01_01; AP01_01 in MF_AP01
e spedire con unico imballo

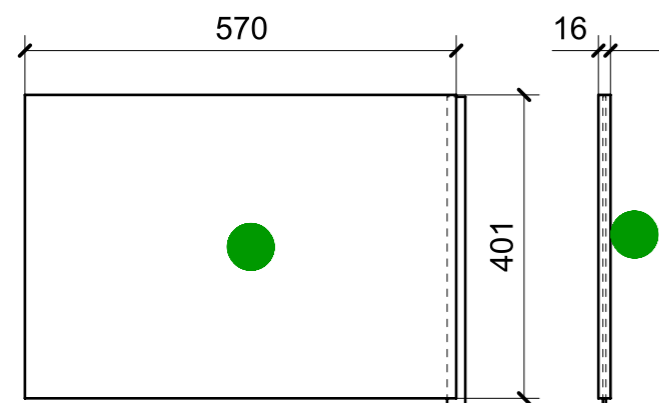
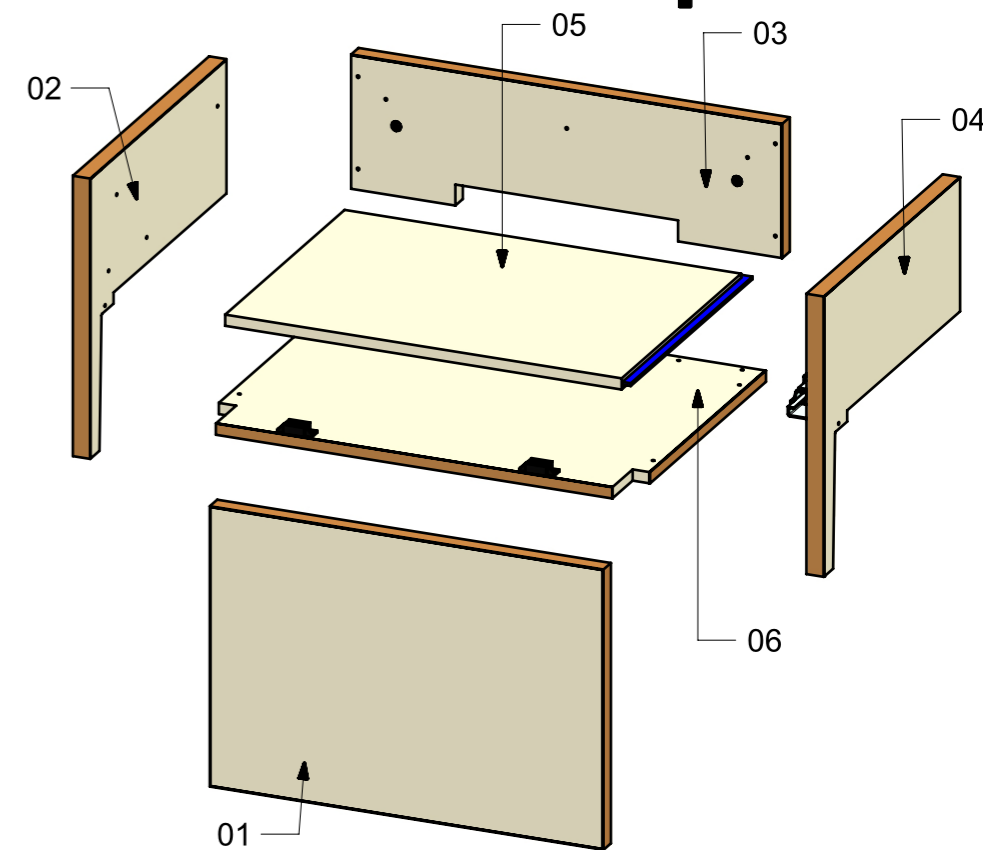

05

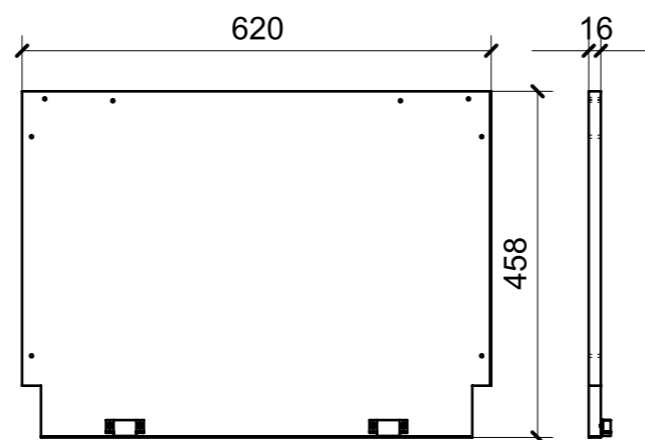

06

FERRAMENTA	QTY
CALAMITA SEALED MAGNETIC_TECNOPARTNER_MC-JM50-BL	2

VERNICIATURA LASTRA/LACCATI:

● = VERNICIARE 1 LATO + FILI RASATI O BORDATI

NESSUN SIMBOLO = VERNICIARE 2 LATI + FILI RASATI O BORDATI

LOCALE	CODICE	DESCRIZIONE COMPONENTE	FINITURA	GR.
CABINA ARMATORE	MD298_R01_AW01	CASSETTIERA Var.3	LASTRA CHIARA	08

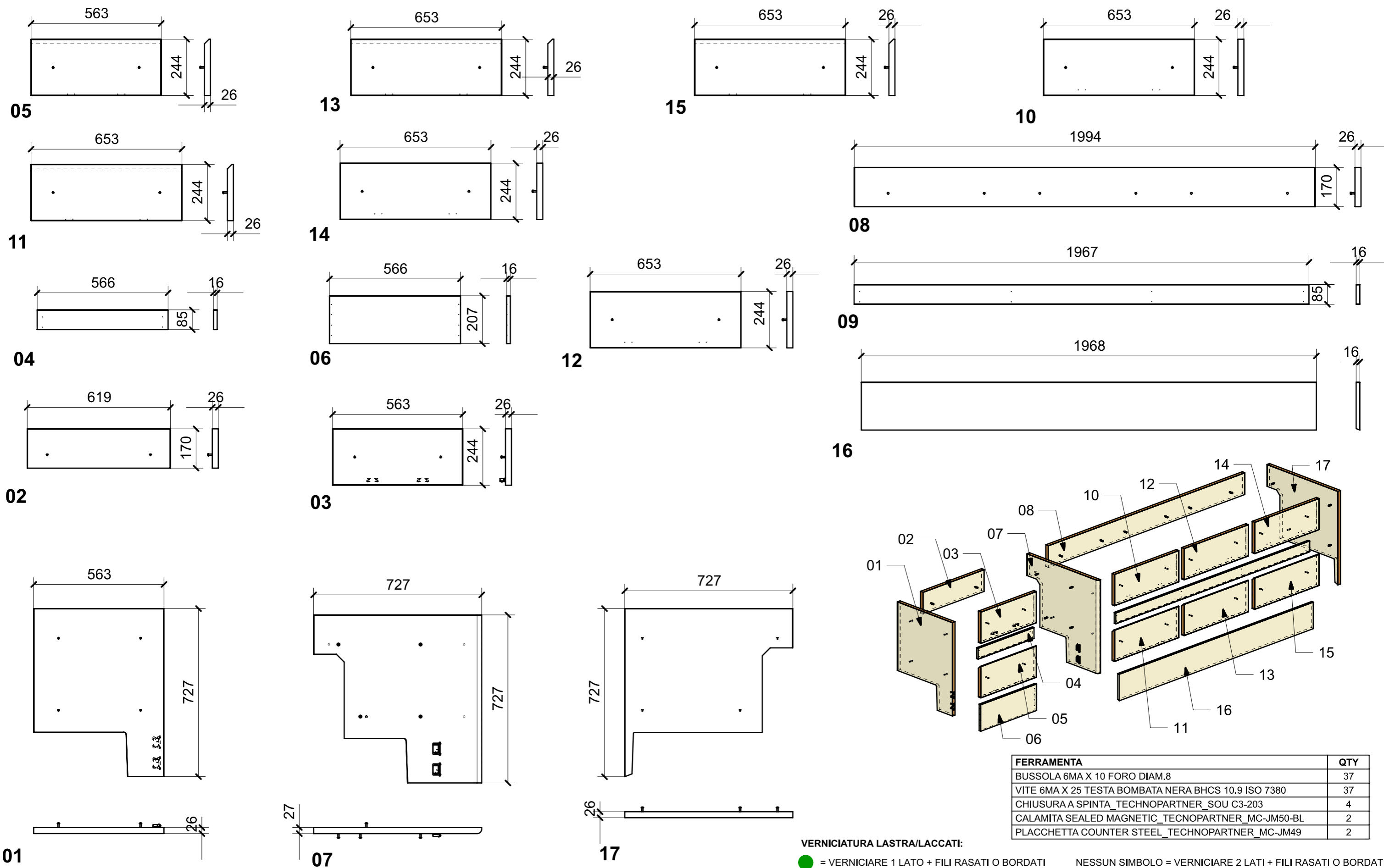

FERRAMENTA	QTY
BUSSOLA 6MA X 10 FORO DIAM.8	37
VITE 6MA X 25 TESTA BOMBATA NERA BHCS 10.9 ISO 7380	37
CHIUSURA A SPINTA_TECHNOPARTNER_SOU C3-203	4
CALAMITA SEALED MAGNETIC_TECNOPARTNER_MC-JM50-BL	2
PLACCHETTA COUNTER STEEL_TECNOPARTNER_MC-JM49	2

VERNICIATURA LASTRA/LACCATI:
● = VERNICIARE 1 LATO + FILI RASATI O BORDATI NESSUN SIMBOLO = VERNICIARE 2 LATI + FILI RASATI O BORDATI

LOCALE	CODICE	DESCRIZIONE COMPONENTE	FINITURA	GR.
CABINA ARMATORE	MD298_R01_AU01	VANITY CASSETTIERA Var.2	LASTRA CHIARA	08

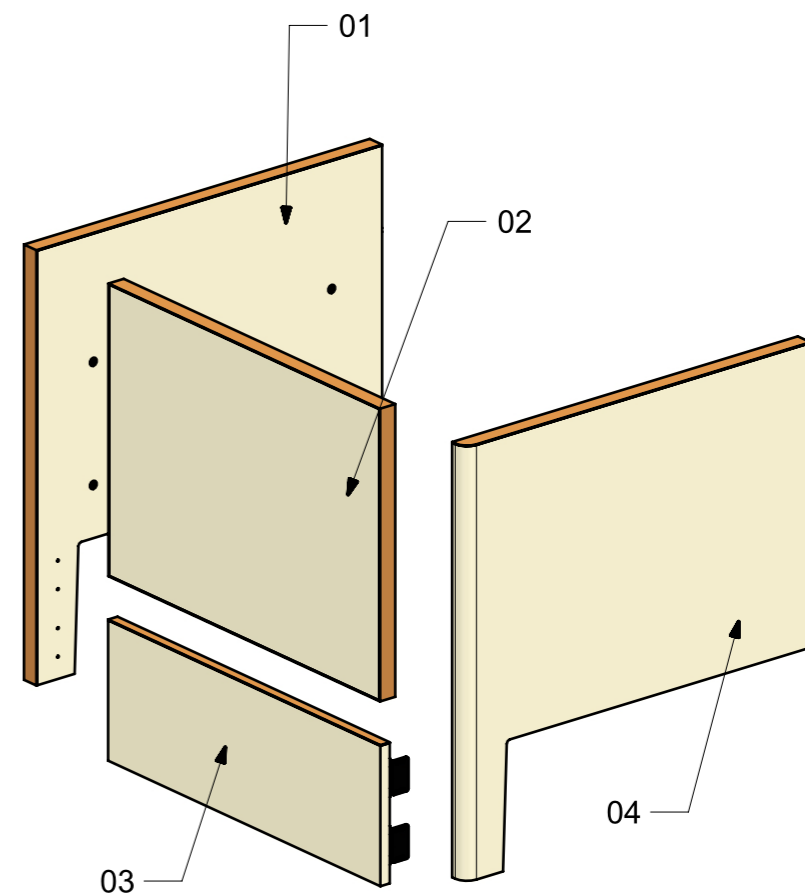
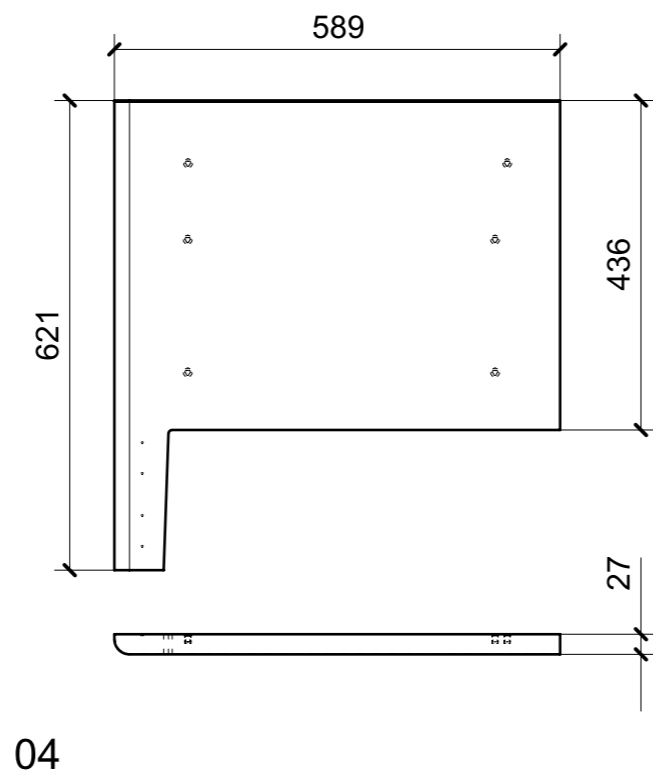
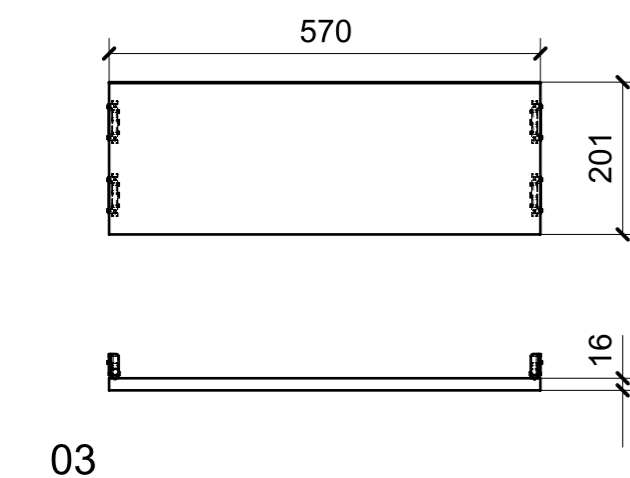
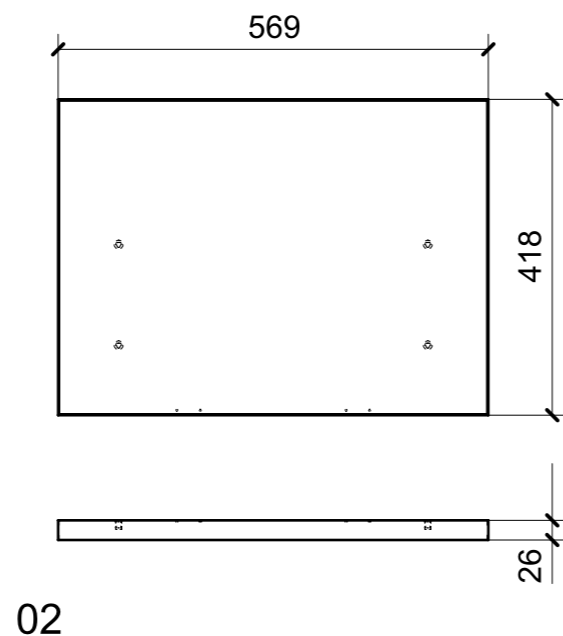
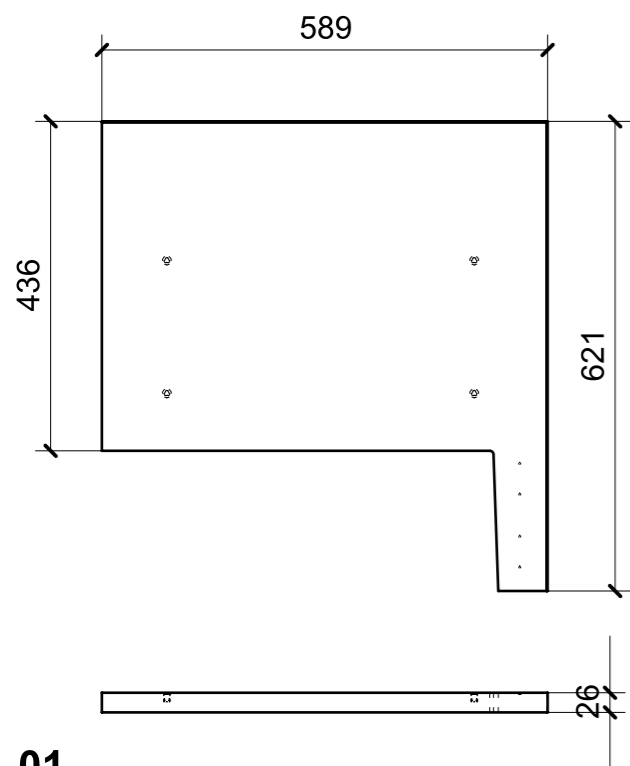

FERRAMENTA	QTY
BUSSOLA 6MA X 10 FORO DIAM.8	14
CHIUSURA A SPINTA_TECHNOPARTNER_SOU C3-203	4

VERNICIATURA LASTRA/LACCATI:

● = VERNICIARE 1 LATO + FILI RASATI O BORDATI

NESSUN SIMBOLO = VERNICIARE 2 LATI + FILI RASATI O BORDATI

LOCALE	CODICE	DESCRIZIONE COMPONENTE	FINITURA	GR.
CABINA ARMATORE	MD298_R01_AX01	VANITY CASSETTIERA PRUA Var.2	LASTRA CHIARA	8

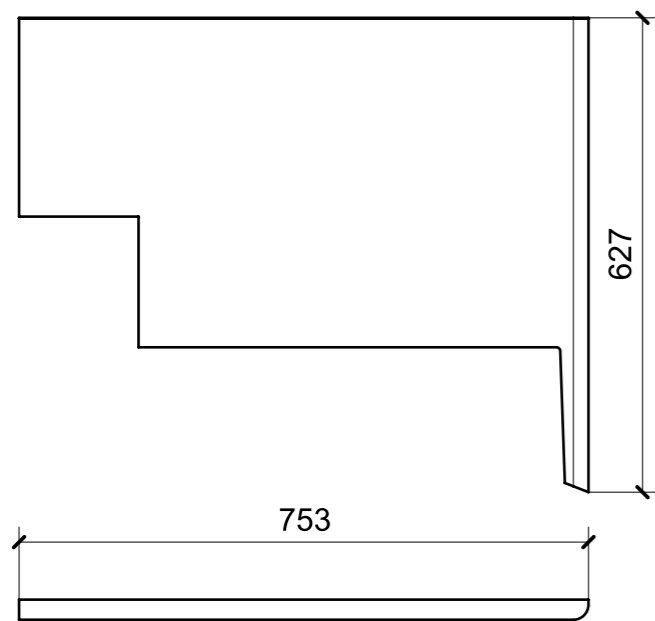

01

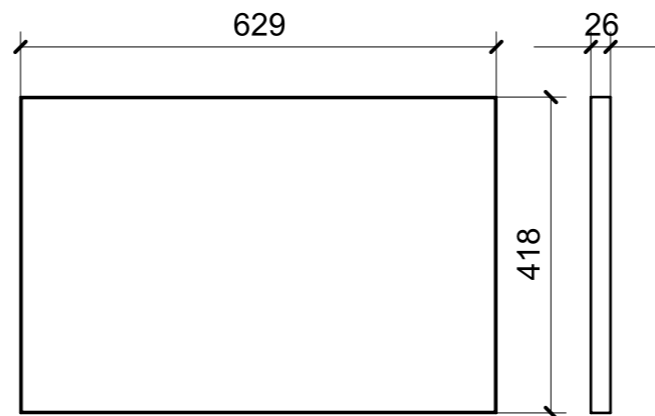

02

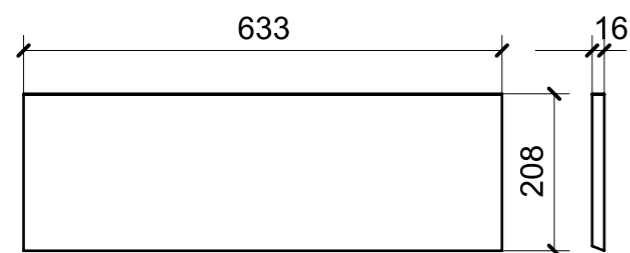
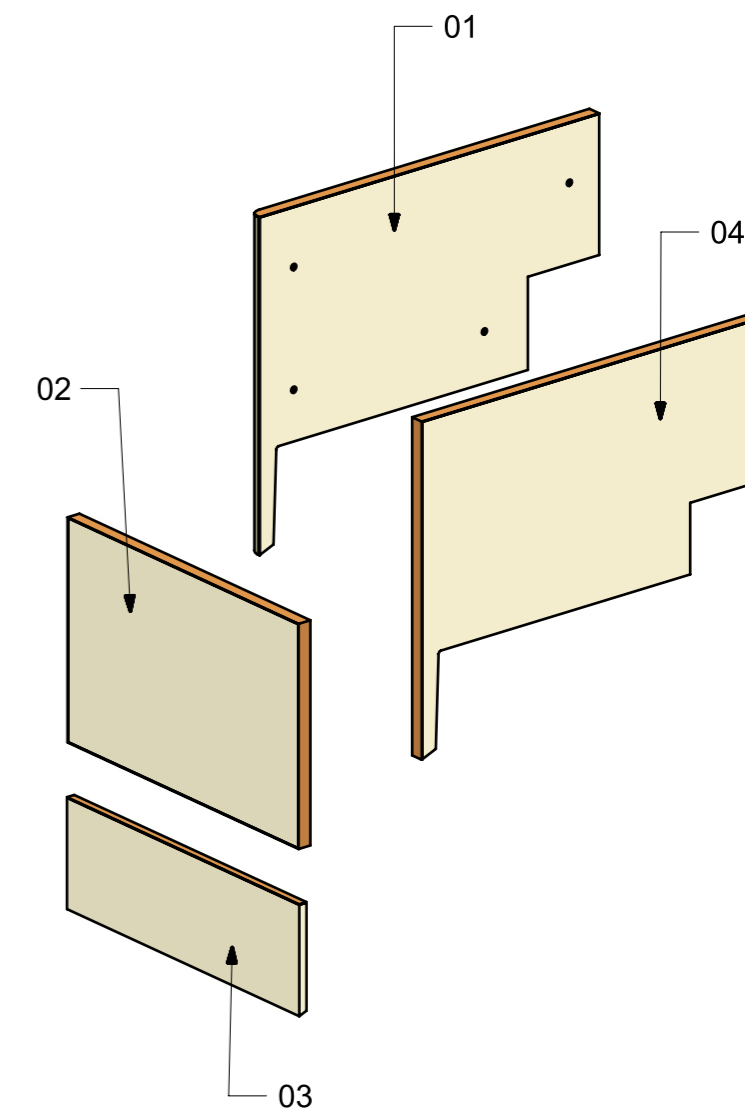

03

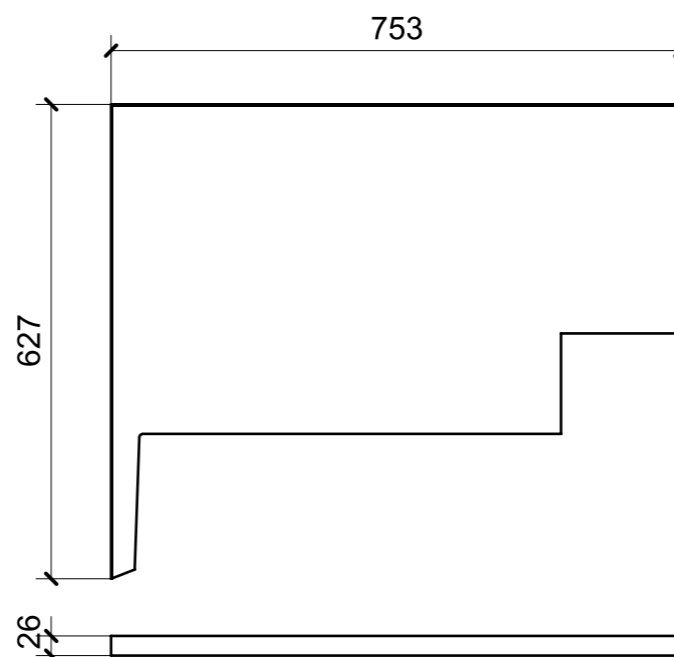

04

FERRAMENTA	QTY
BUSSOLA 6MA X 10 FORO DIAM.8	12

VERNICIATURA LASTRA/LACCATI:

● = VERNICIARE 1 LATO + FILI RASATI O BORDATI

NESSUN SIMBOLO = VERNICIARE 2 LATI + FILI RASATI O BORDATI