

LOCALE	CODICE	DESCRIZIONE COMPONENTE	FINITURA	Q.TA
SALONE	MD298_MF_SP01	TAVOLO SALONE STD		1

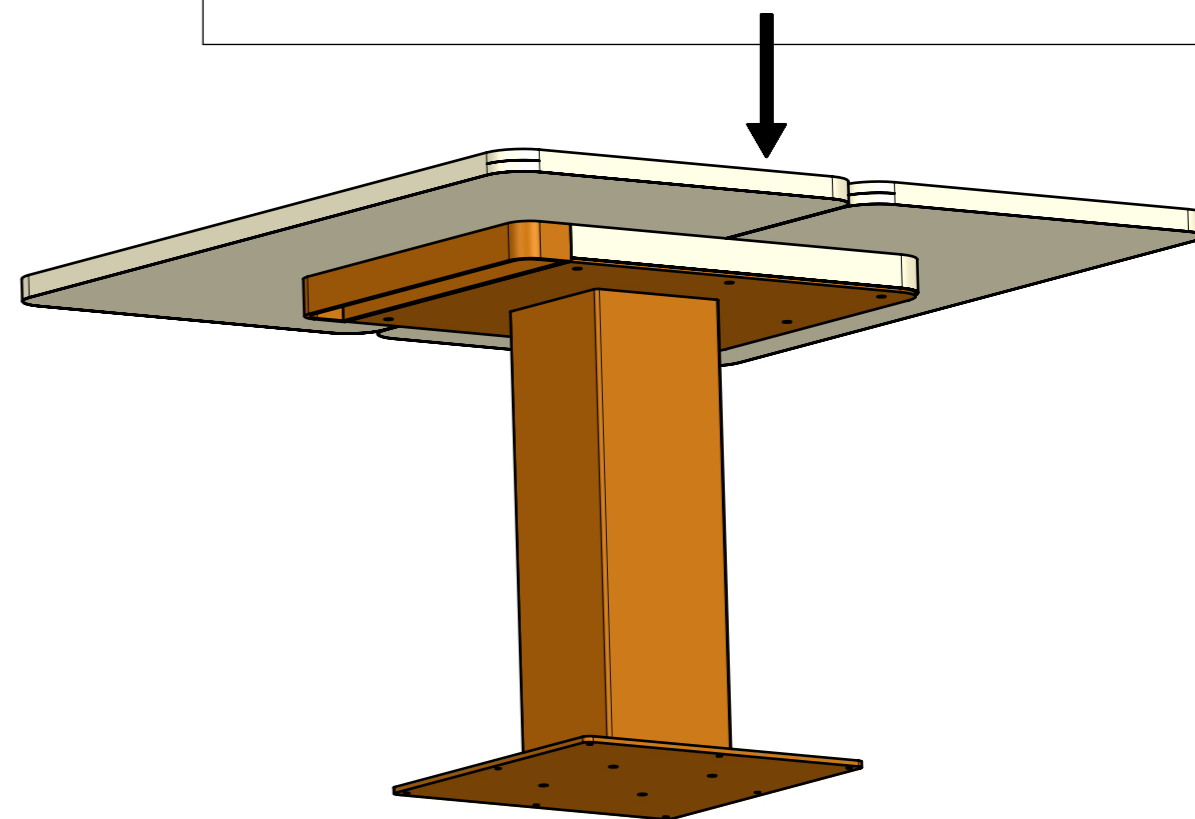

LOCALE	CODICE	DESCRIZIONE COMPONENTE	FINITURA	Q.TA
SALONE	MD298_MF_SQ01	TAVOLO SALONE OPT		1

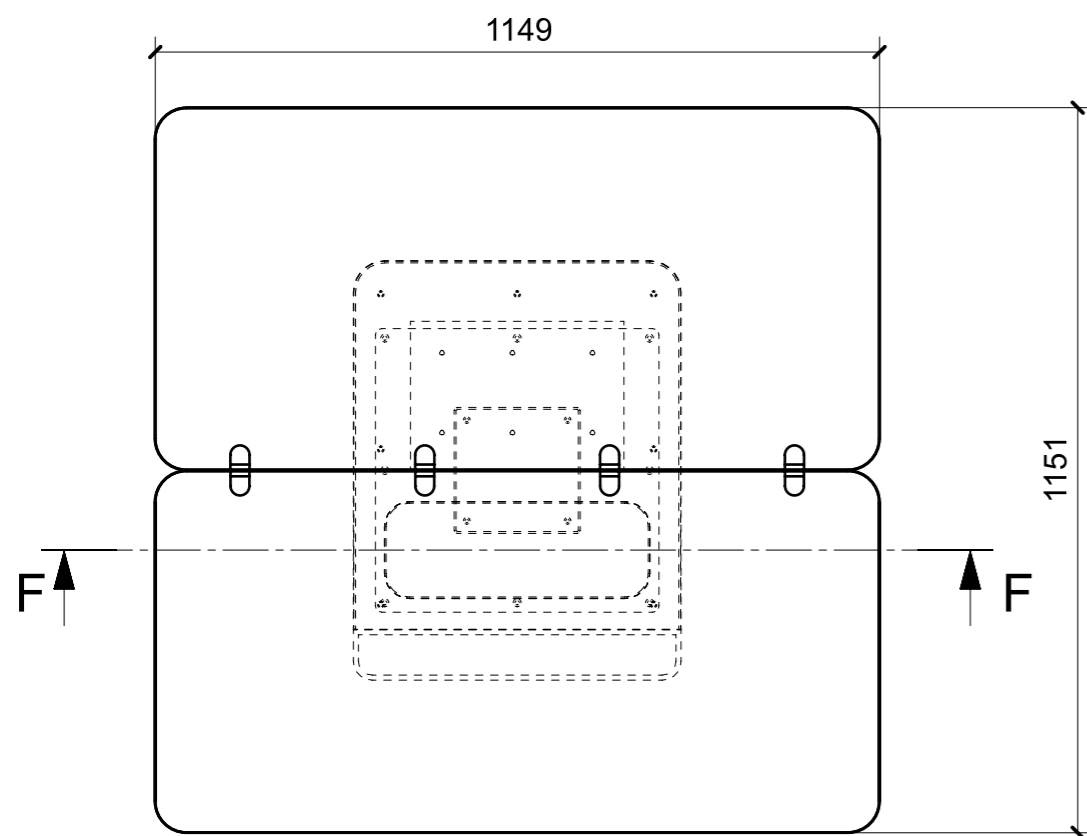
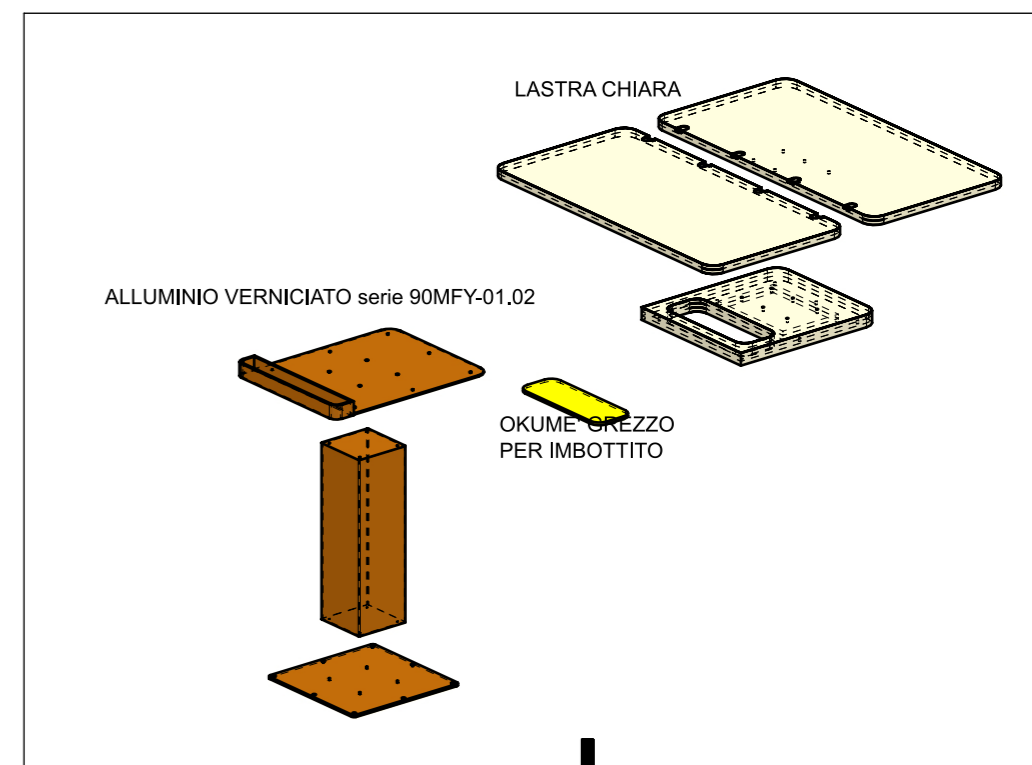
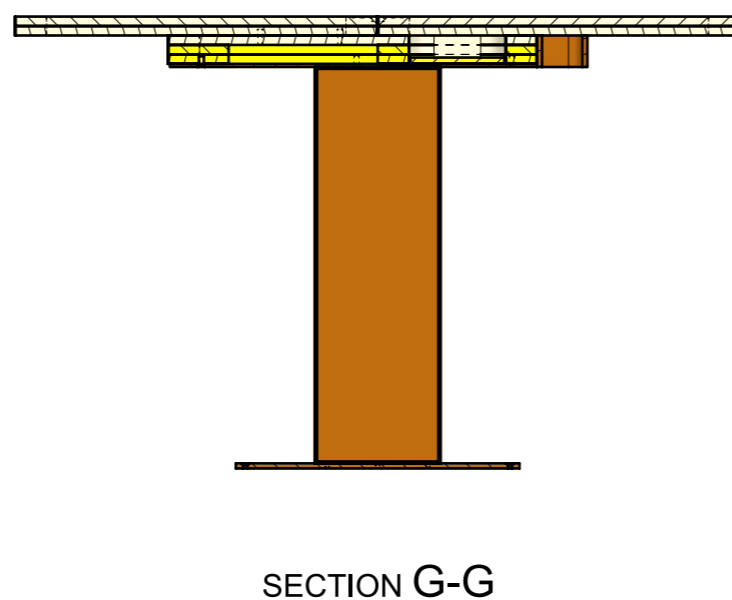
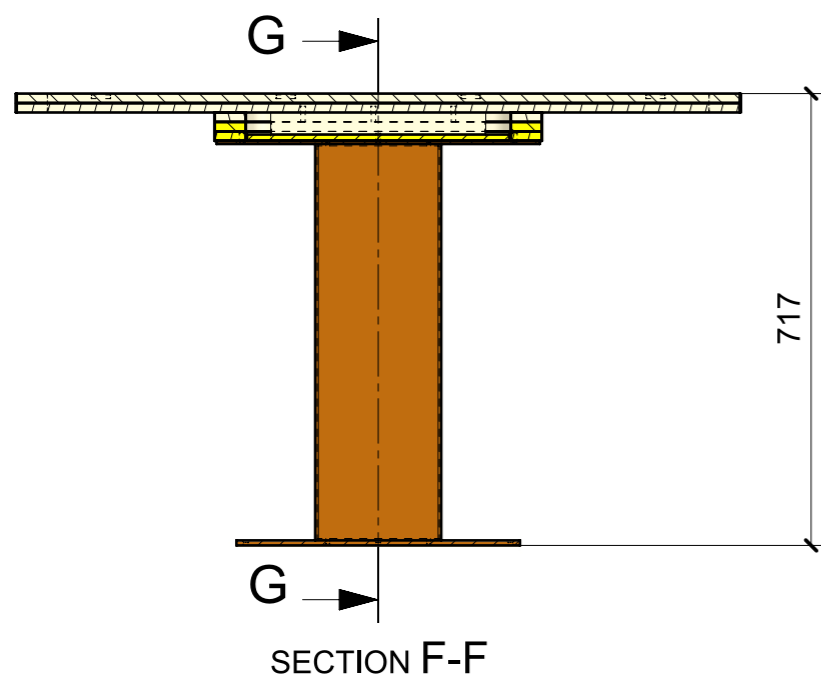
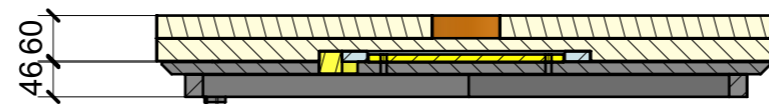
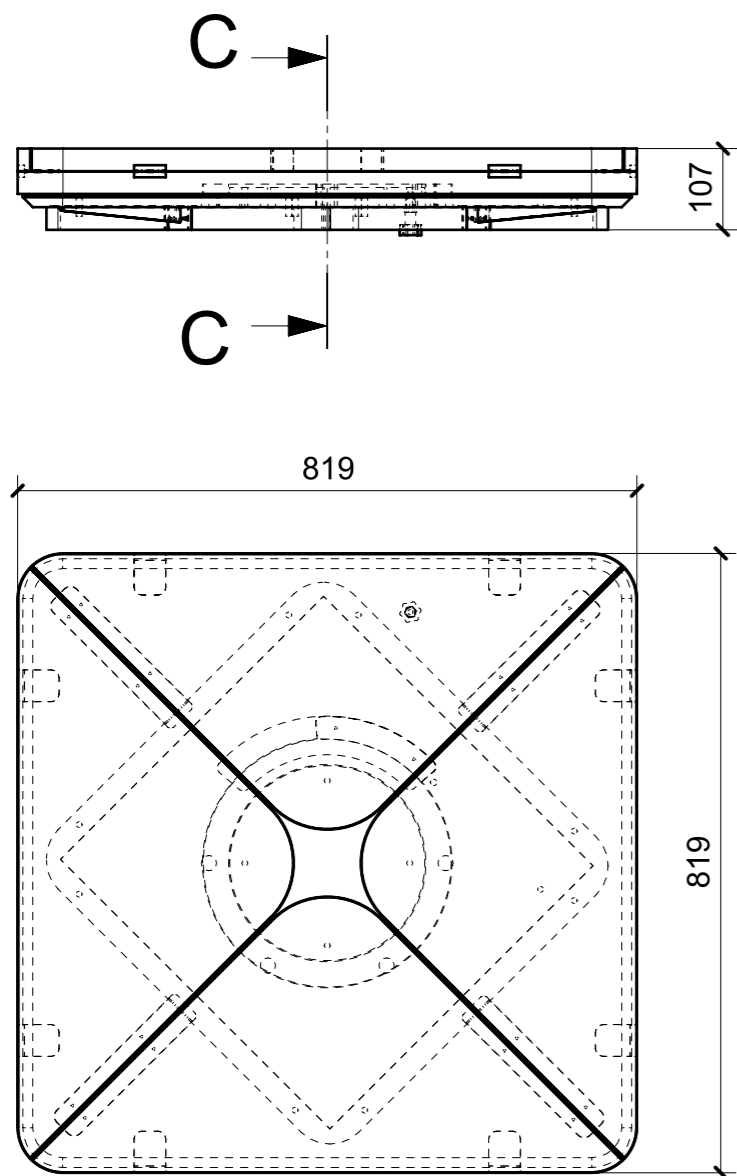

SECTION C-C

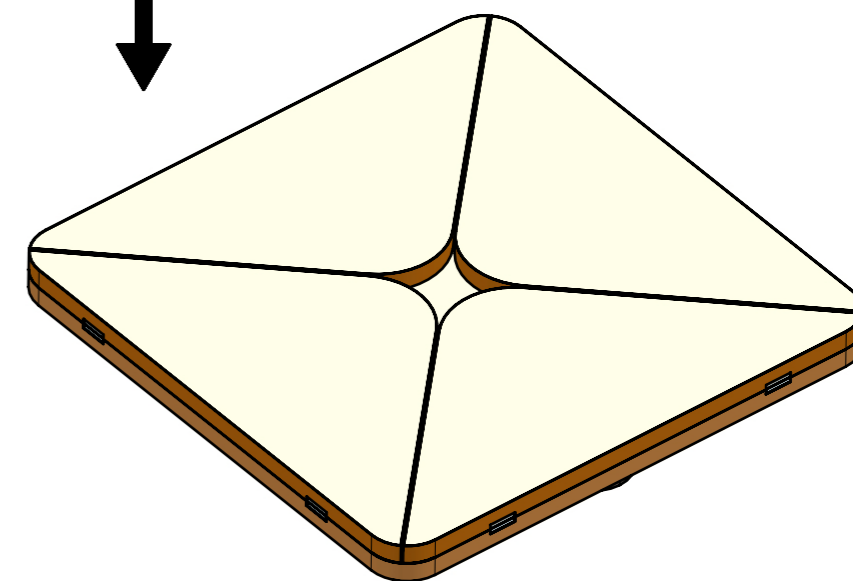
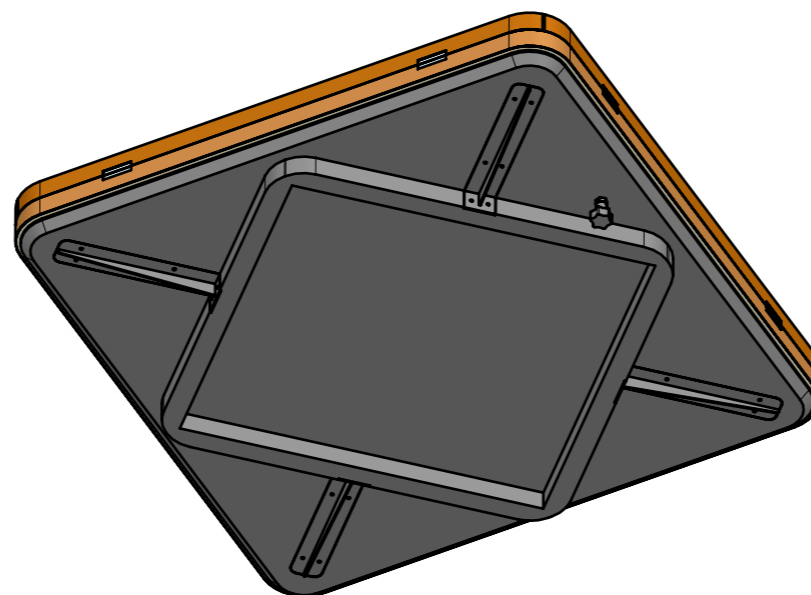
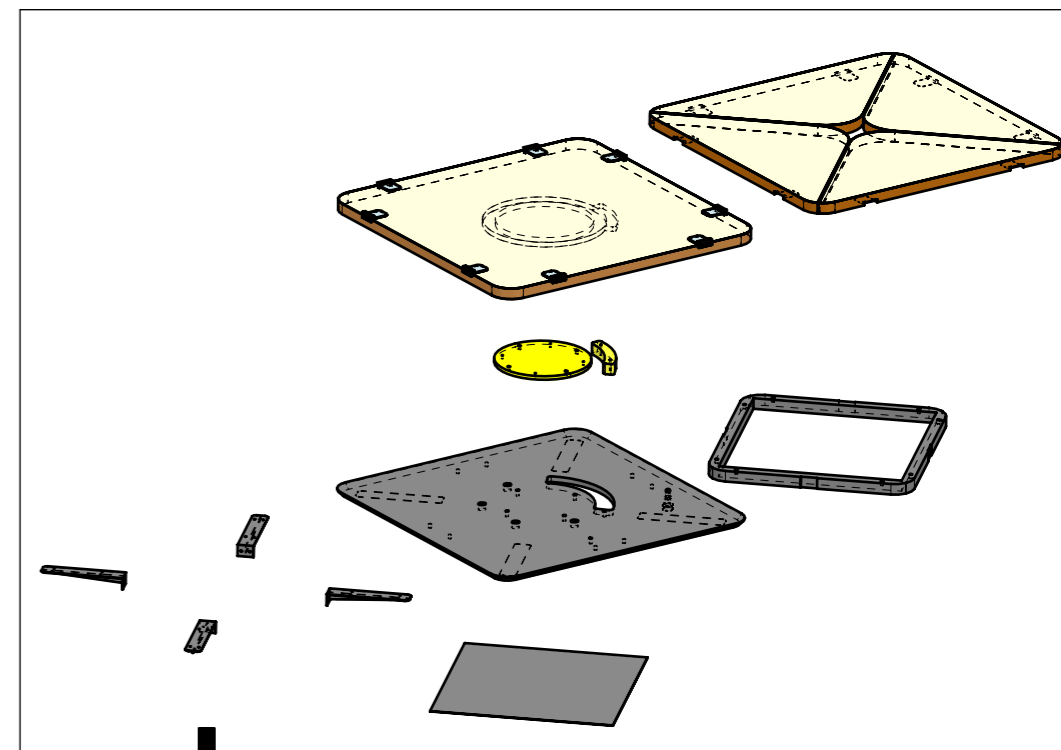

FERRAMENTA	QTY
PIATTO GIREVOLE_HAFELE_646_27_347	1
CERNIERA A RIBALTA 180_OSCULATI_38_292_00	8
FERMO PER TAVOLO GIREVOLE	1