

LOCALE	CODICE	DESCRIZIONE COMPONENTE	FINITURA	Q.TA
LOBBY	MD298_CA01	MOBILE LAVATRICE	LAMINATO LG23 PORO ROVERE	1

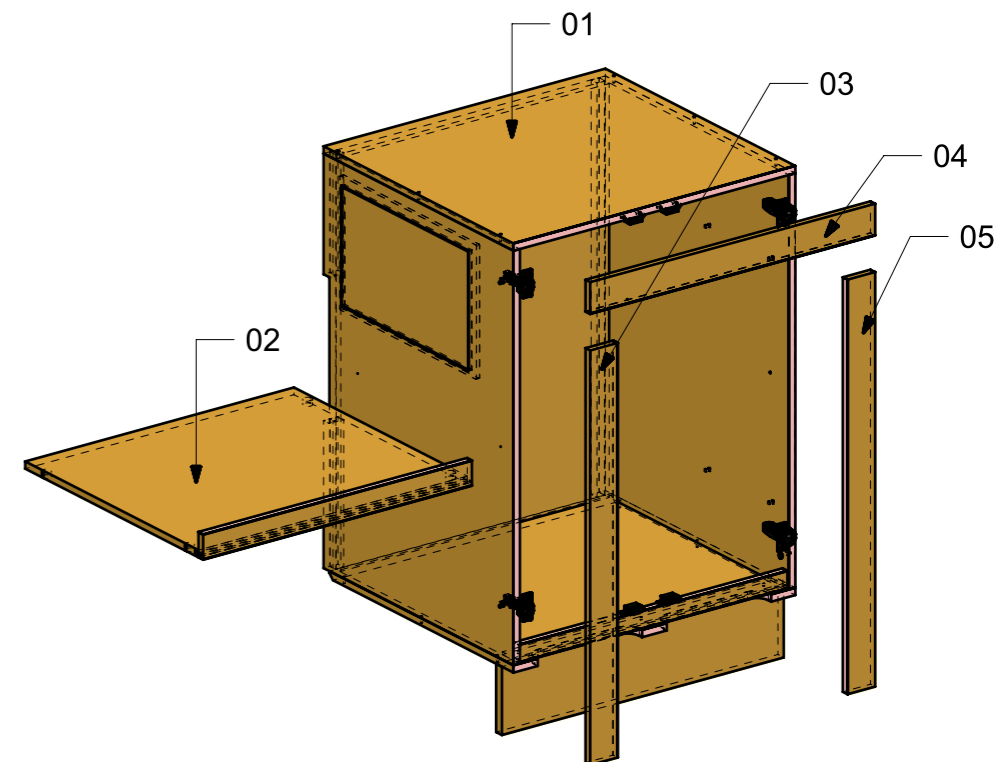
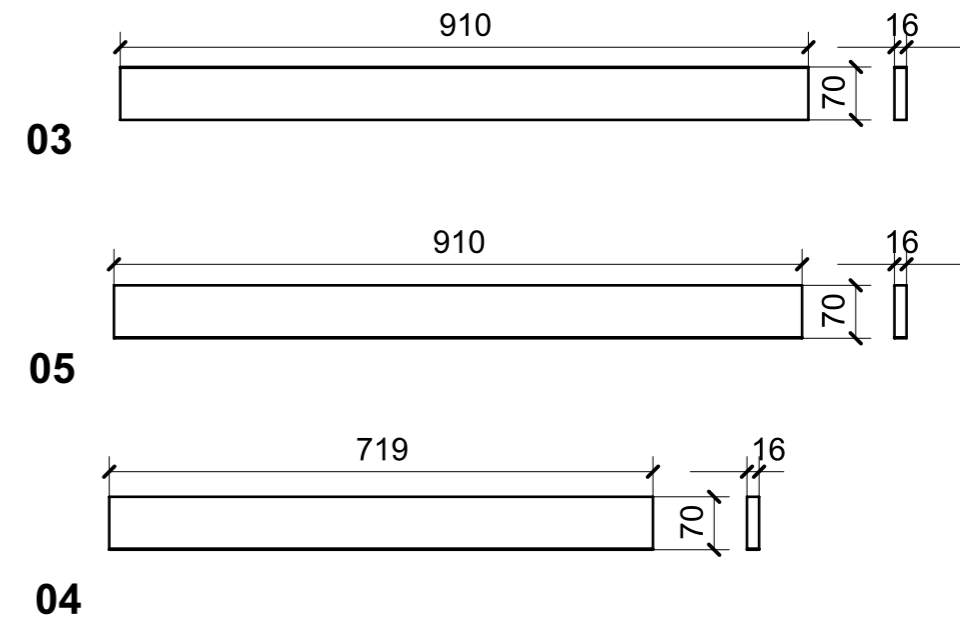
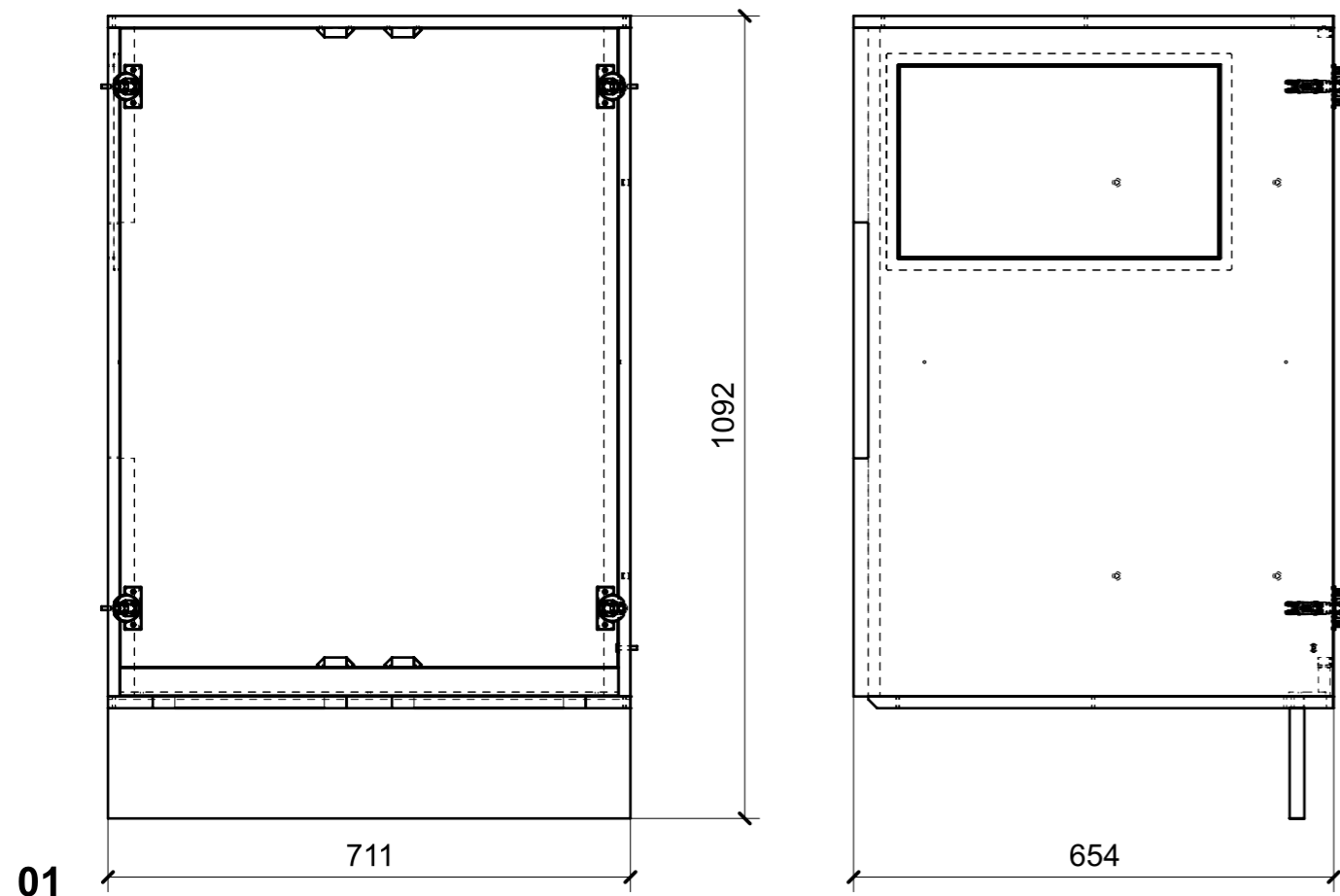

FERRAMENTA	QTY
BASE_3-NERA_HAFELE_342.22.067-BLUM_175H3130.STP	4
BUSSOLA 5MA ANKOR BORGHI	16
BUSSOLA 6MA X 10 FORO DIAM.8	4
CALAMITA SEALED MAGNETIC_TECNOPARTNER_MC-JM50-BL	4
CERNIERA 94°_PIANA-NERA_HAFELE_342.46.604-BLUM_71B9550.STP	4
COPERTURA BRACCIO CERNIERA NERO-HAFELE_342.94.602-BLUM_70.1503.STP	4
COPERTURA GABBIA CERNIERA NERO_HAFE_342.45.032-BLUM_70T3504.STP	4
VITE 4MAX8 ANKOR BORGHI	16
VITE 5MA X 25 TESTA BOMBATA	1
VITE 5MA X 25 TESTA SVASATA	3

02

LOCALE	CODICE	DESCRIZIONE COMPONENTE	FINITURA	GR.
LOBBY	MD298_CC01	ARMADIO SOTTOSCALA	LAMINATO LG23 PORO ROVERE\ GREZZO	8

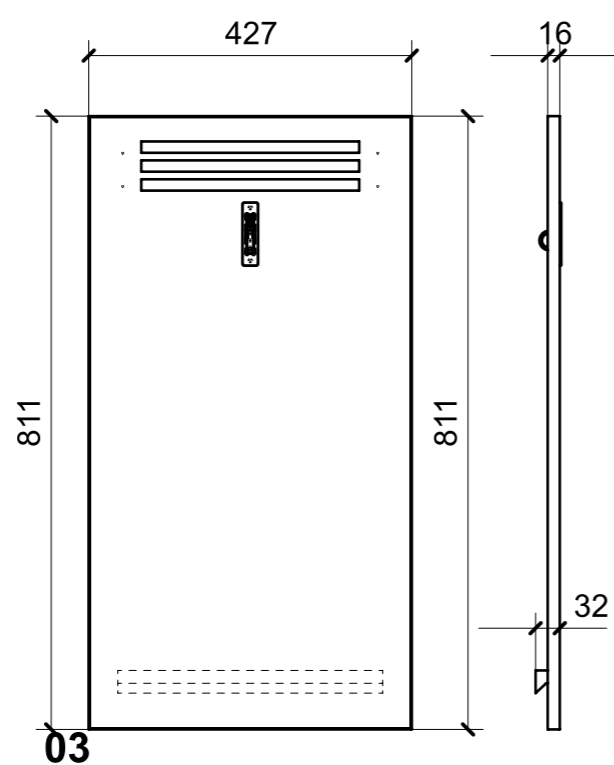
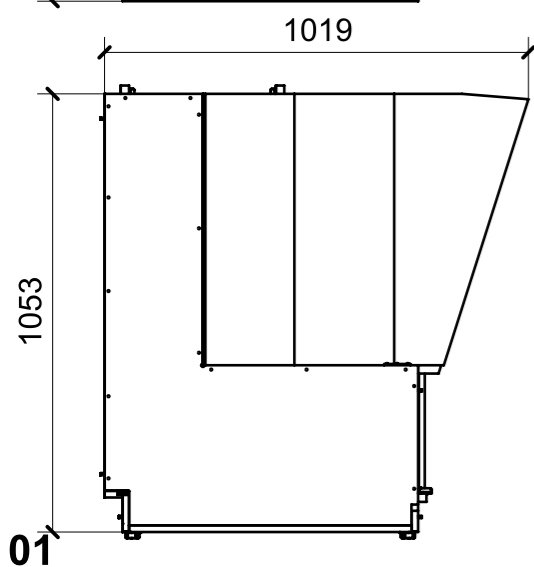
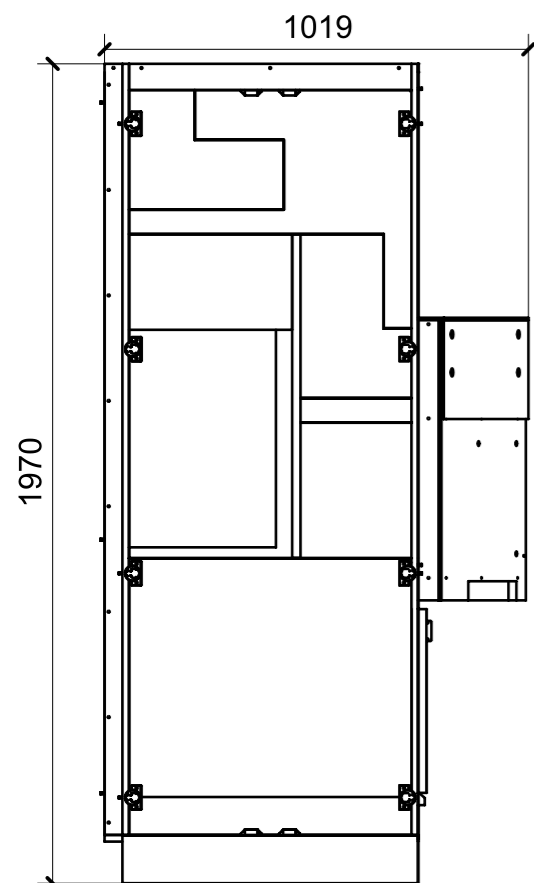

FERRAMENTA	QTY
ALZAPAGLIOLI_FORESTI_164.C	1

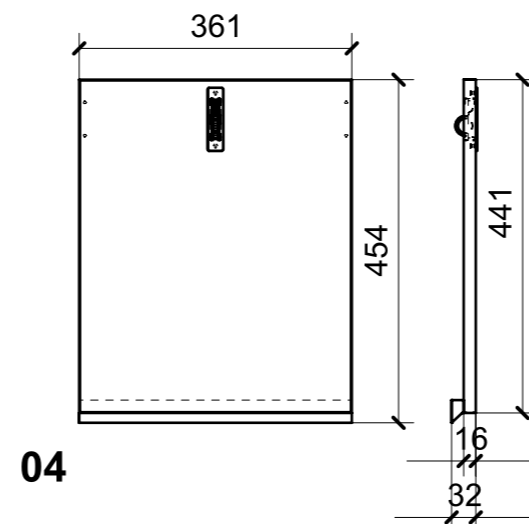

FERRAMENTA	QTY
ALZAPAGLIOLI_FORESTI_164.C	1

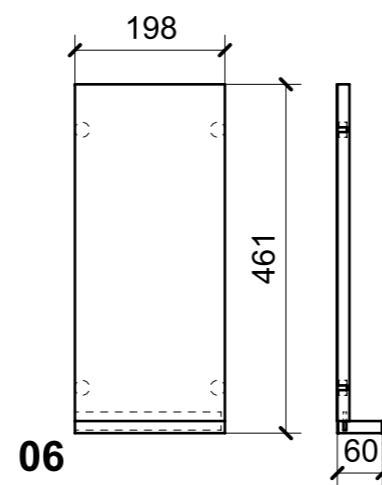
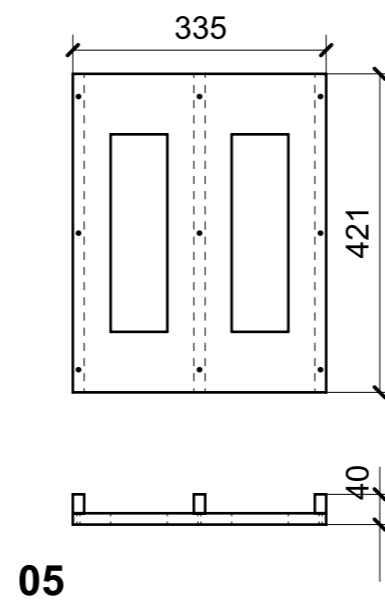
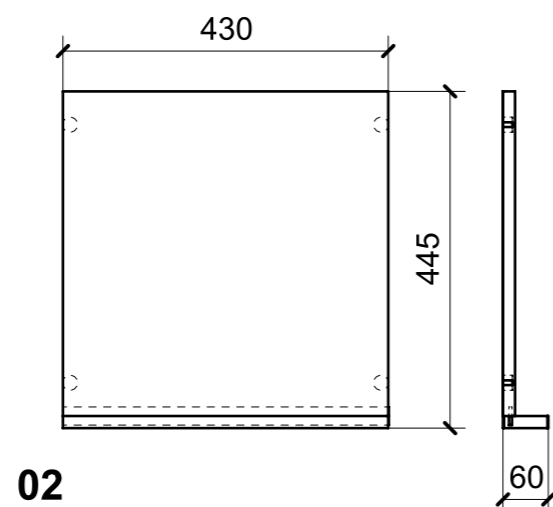

FERRAMENTA	QTY
BASE_3-NERA_HAFELE_342.22.067-BLUM_175H3130.STP	8
BUSSOLA 5MA ANKOR BORGHI	32
BUSSOLA 6MA X 10 FORO DIAM.8	5
CALAMITA SEALED MAGNETIC_TECNOPARTNER_MC-JM50-BL	4
CERNIERA 94°_PIANA-NERA_HAFELE_342.46.604-BLUM_71B9550.STP	8
CHIUSURA A SPINTA_TECNOPARTNER_SOU C3-203	4
COPERTURA BRACCIO CERNIERA NERO-HAFELE_342.94.602-BLUM_70.1503.STP	8
COPERTURA GABBIA CERNIERA NERO_HAFE_342.45.032-BLUM_70T3504.STP	8
FITLOCK F_MASCHERPA_6020101102	1
FITLOCK M_MASCHERPA_3MM_6020202101	1
VITE 4MAX8 ANKOR BORGHI	32
VITE 5MA X 25 TESTA BOMBATA	2
VITE 5MA X 25 TESTA SVASATA	5
VITE 5MA X 30 TESTA BOMBATA	4

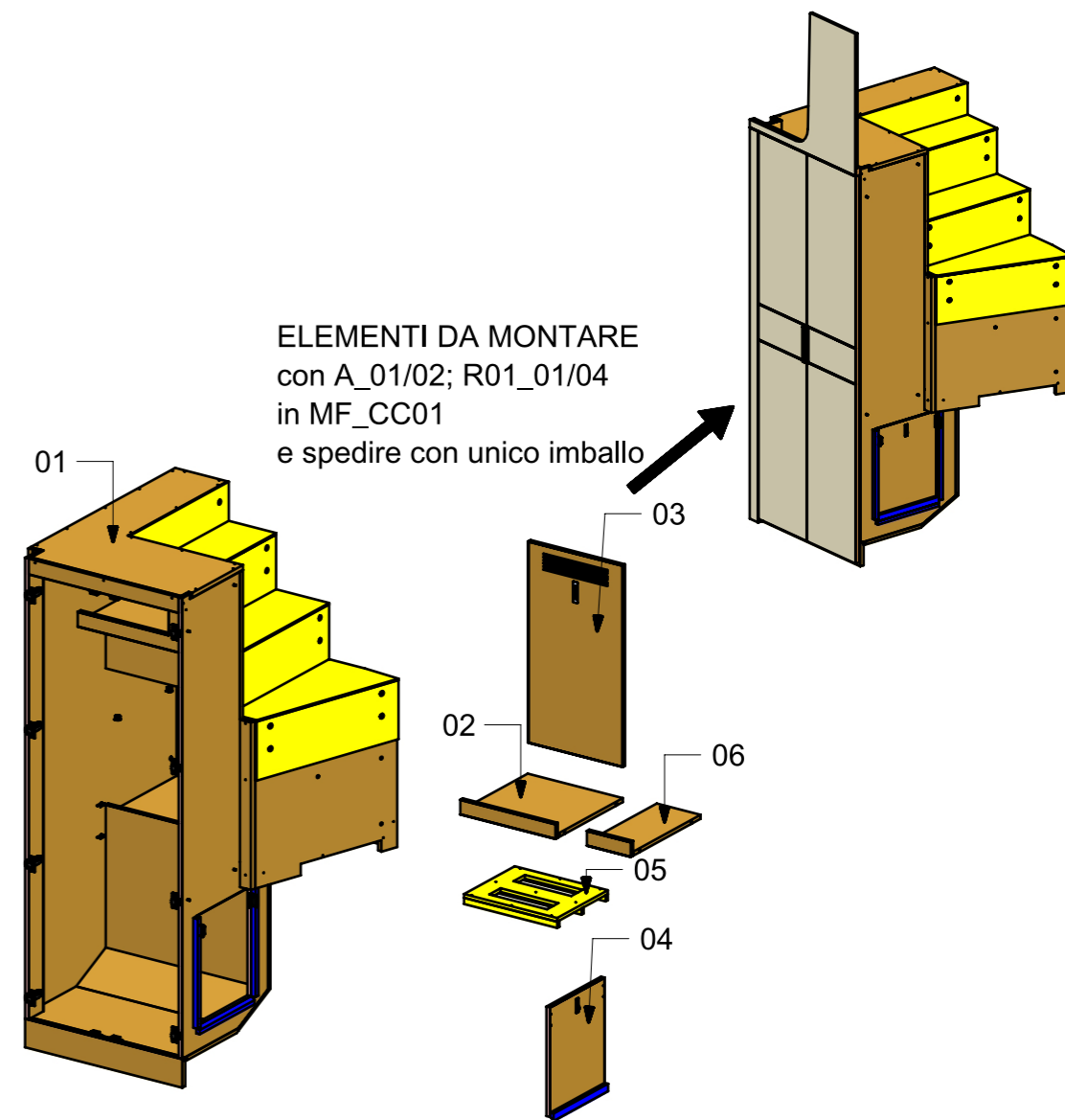

LOCALE	CODICE	DESCRIZIONE COMPONENTE	FINITURA	GR
LOBBY	MD298_CD01	STRUTTURA GRADINI PIANEROTTOLO	OKUME' GREZZO	8

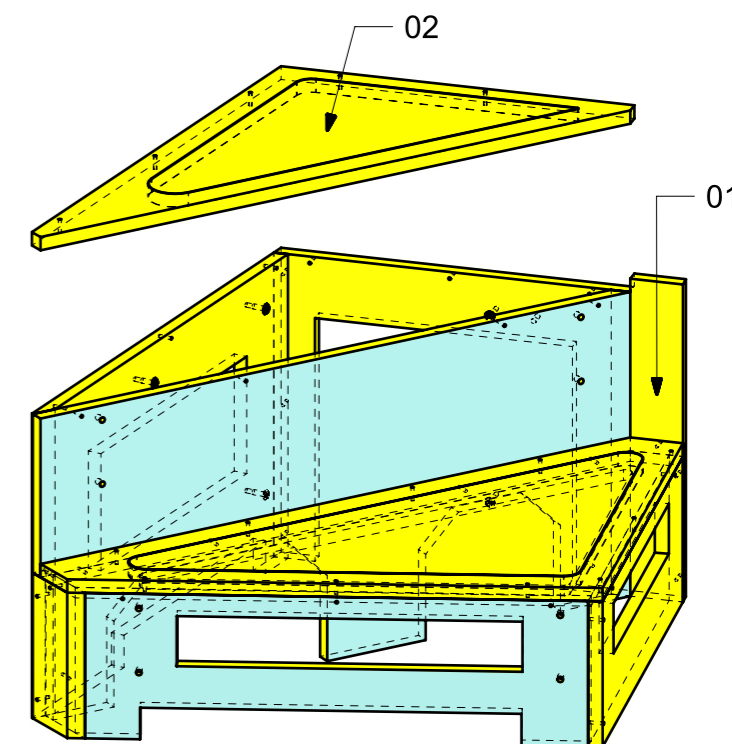
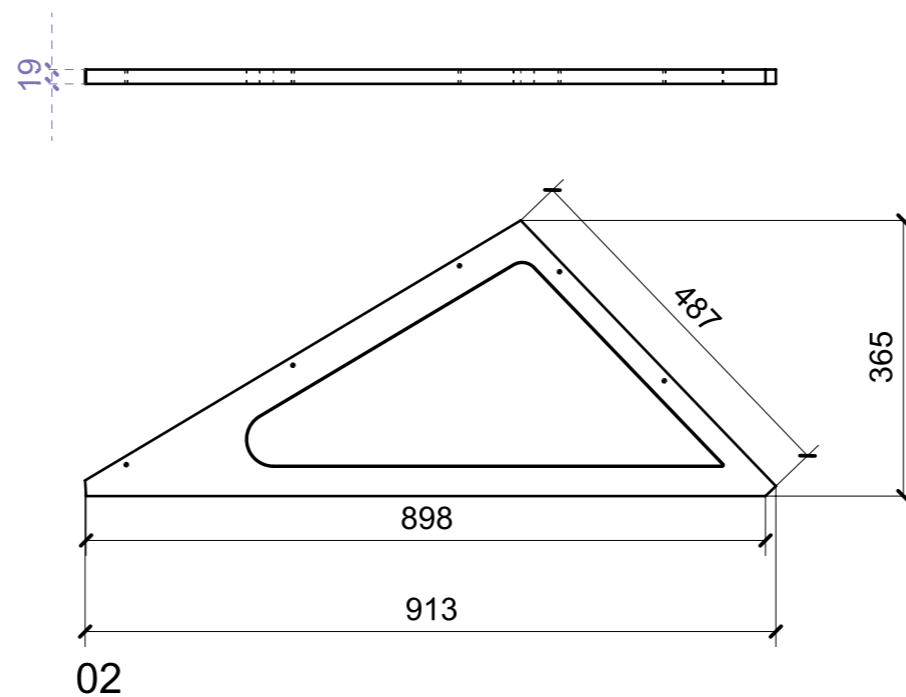
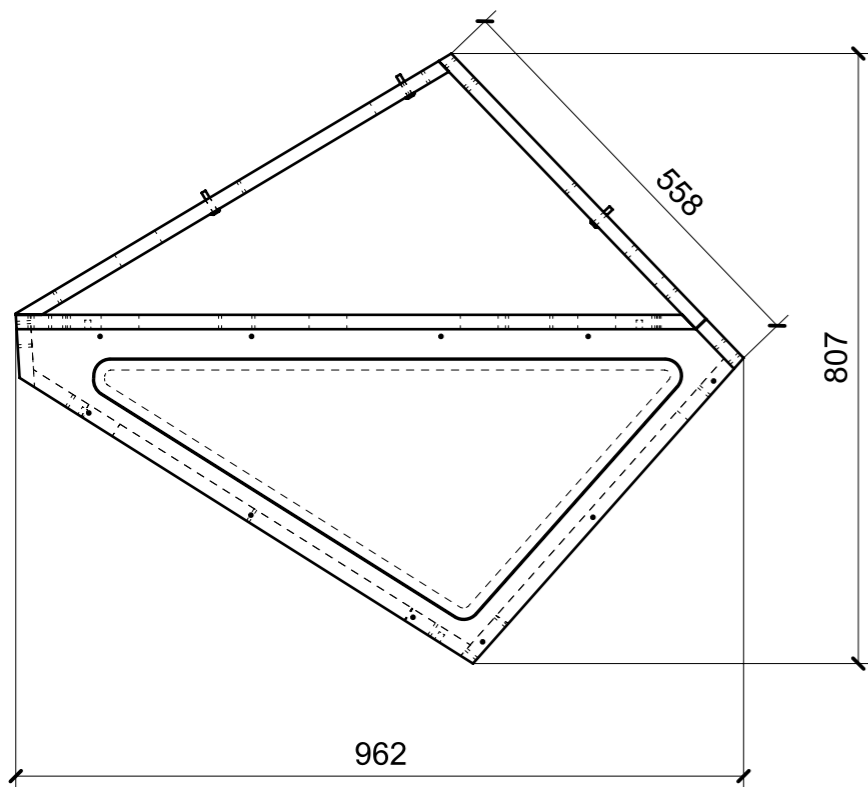
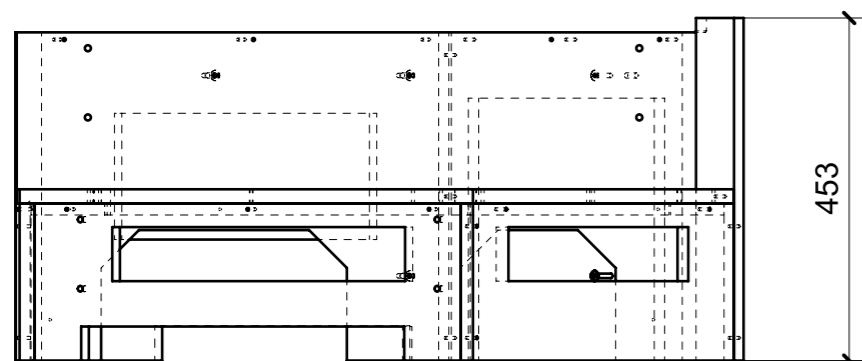

FERRAMENTA	QTY
VITE 6MA X 30 TESTA BOMBATA	5

01

LOCALE	CODICE	DESCRIZIONE COMPONENTE	FINITURA	Q.TA
LOBBY	MD298_CE01	SPESSORAMENTI PER LED GRADINI	OKUME' GREZZO	1

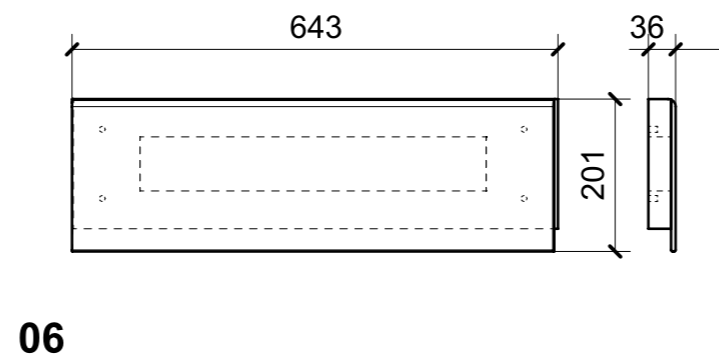
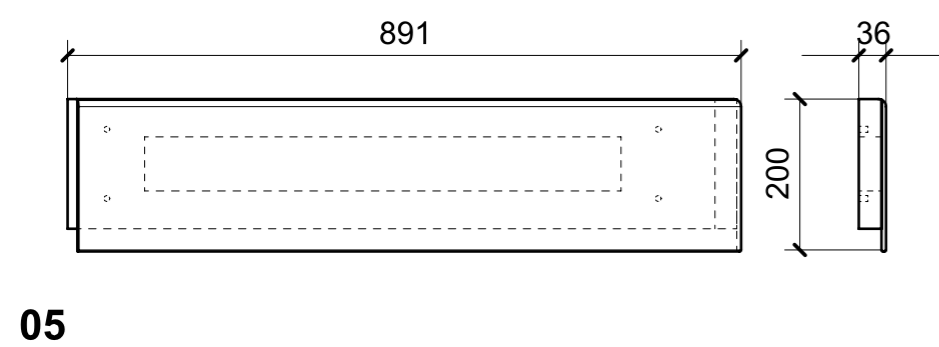
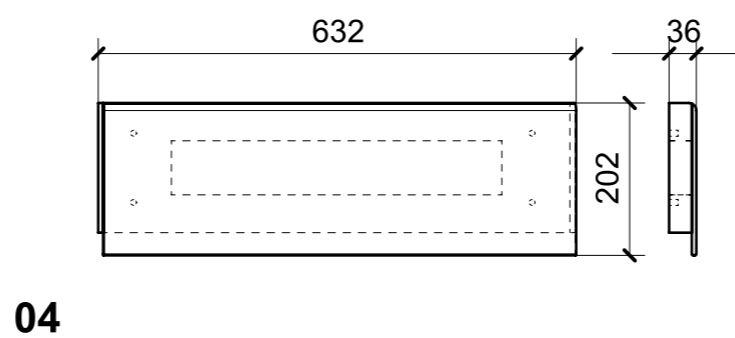
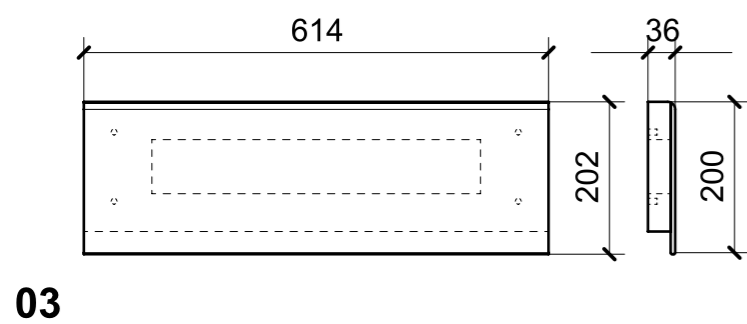
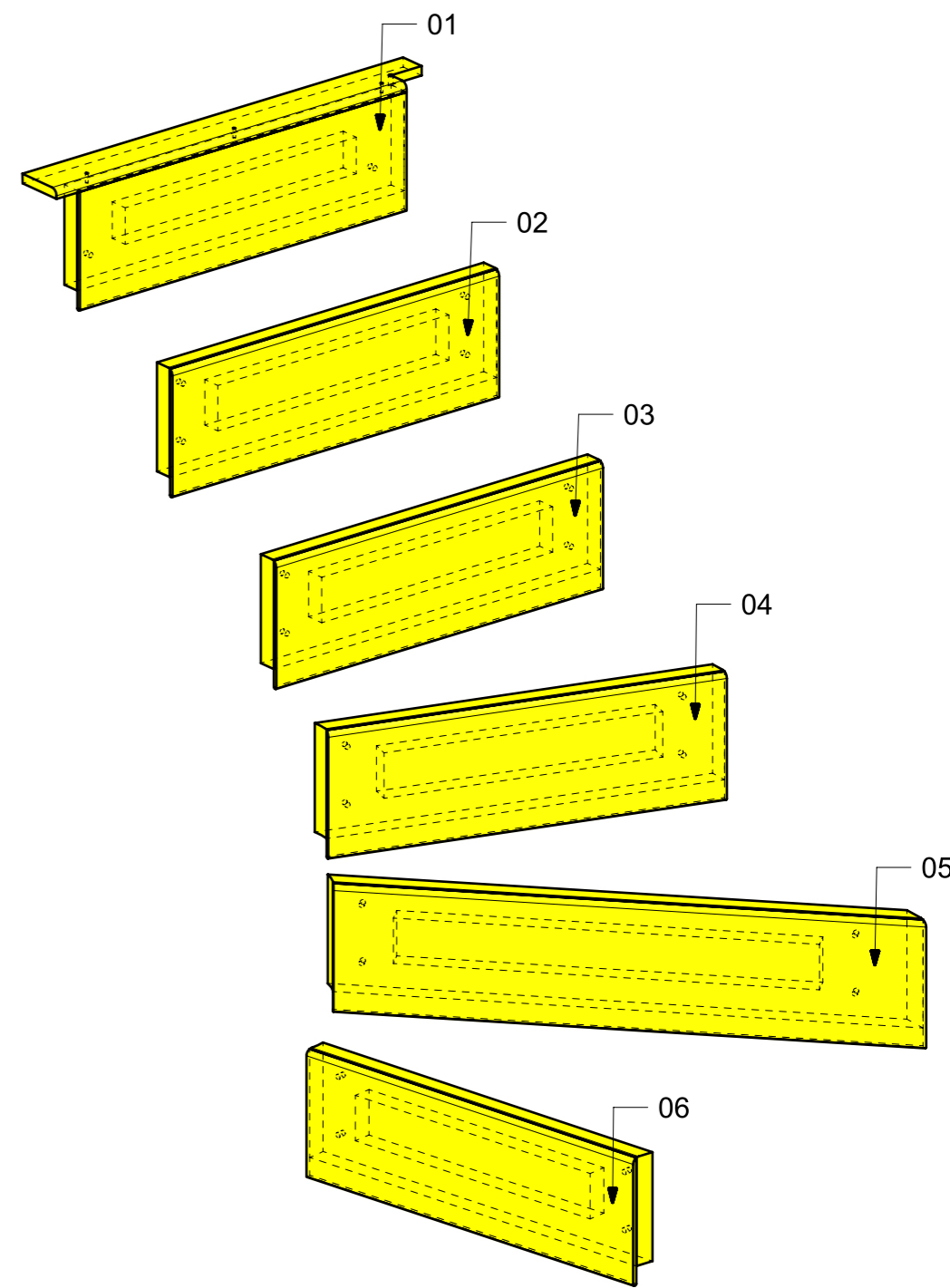
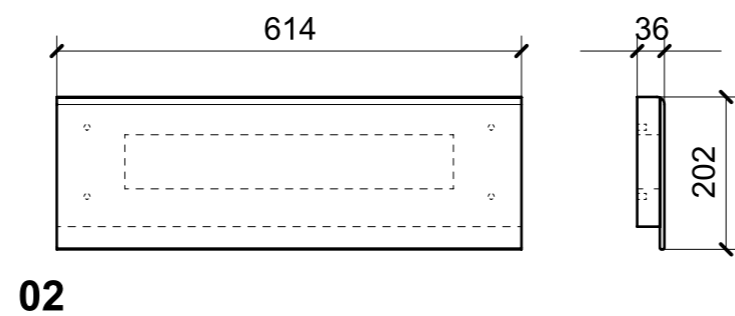
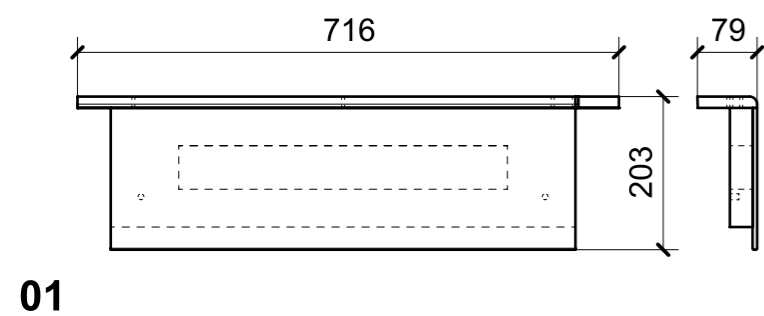

LOCALE	CODICE	DESCRIZIONE COMPONENTE	FINITURA	GR
LOBBY	MD298_CF01	MOBILE WINE COOLER	LAMINATO LG23 PORO ROVERE\ GREZZO	8

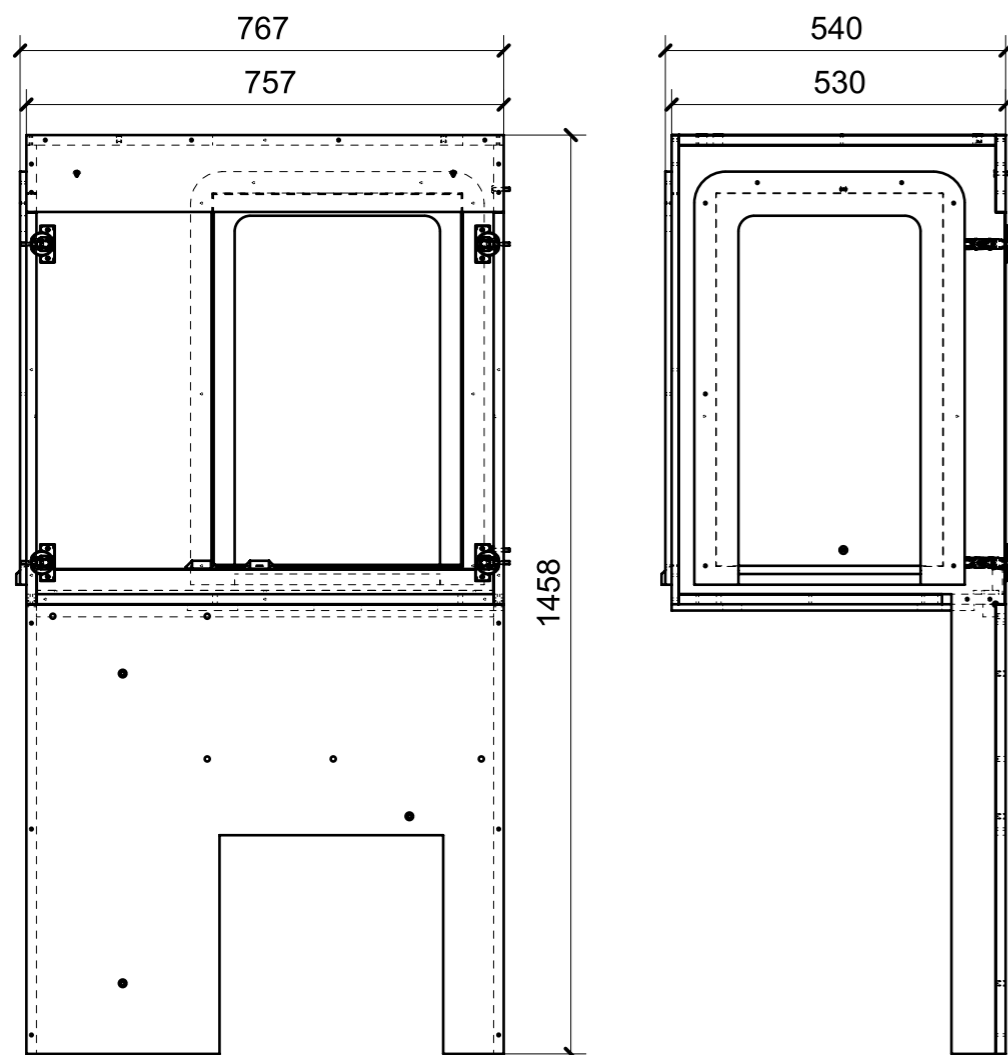

01

FERRAMENTA	QTY
BASE_3-NERA_HAFELE_342.22.067-BLUM_175H3130.STP	4
BUSSOLA 5MA ANKOR BORGHI	18
BUSSOLA 6MA X 10 FORO DIAM.8	5
CALAMITA SEALED MAGNETIC_TECNOPARTNER_MC-JM50-BL	2
CERNIERA 94°_PIANA-NERA_HAFELE_342.46.604-BLUM_71B9550.STP	4
COPERTURA BRACCIO CERNIERA NERO-HAFELE_342.94.602-BLUM_70.1503.STP	4
COPERTURA GABBIA CERNIERA NERO_HAFE_342.45.032-BLUM_70T3504.STP	4
VITE 4MAX8 ANKOR BORGHI	18
VITE 5MA X 25 TESTA BOMBATA	4
VITE 5MA X 25 TESTA SVASATA	4

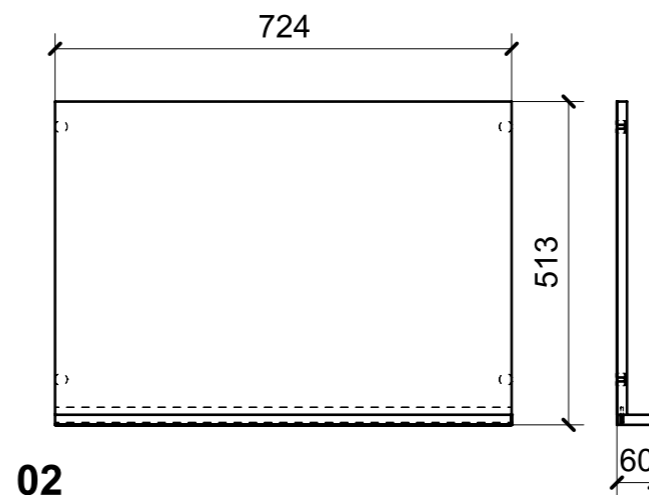

02

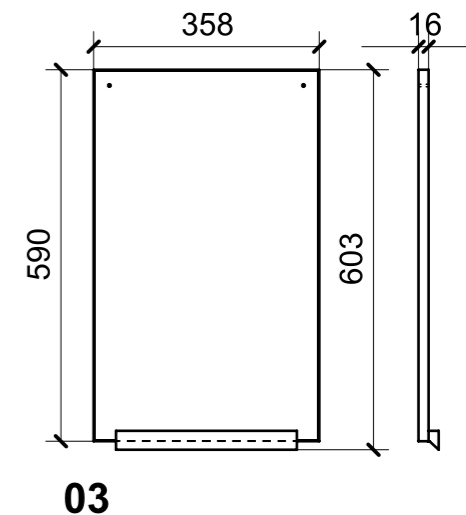

03

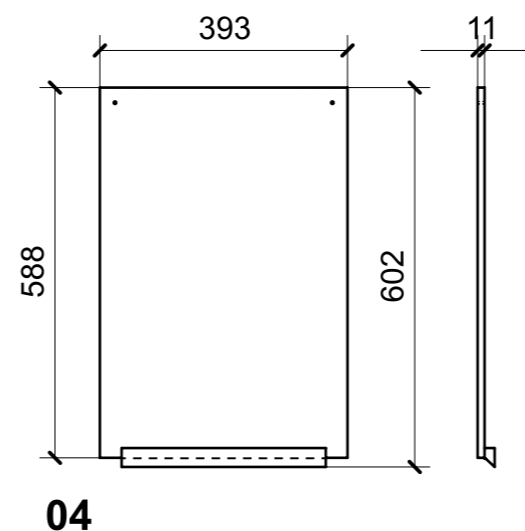

04

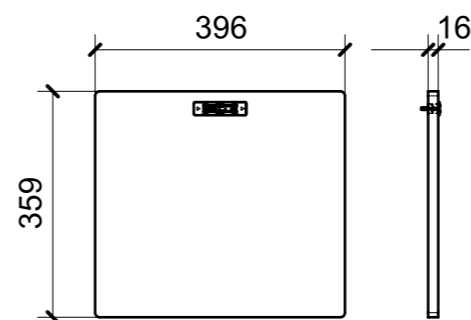

05

FERRAMENTA	QTY
ALZAPAGLIOLI_FORESTI_164.C	1

ELEMENTI DA MONTARE
con L01_CF01_01-->02 in MF_CF01
e spedire con unico imballo

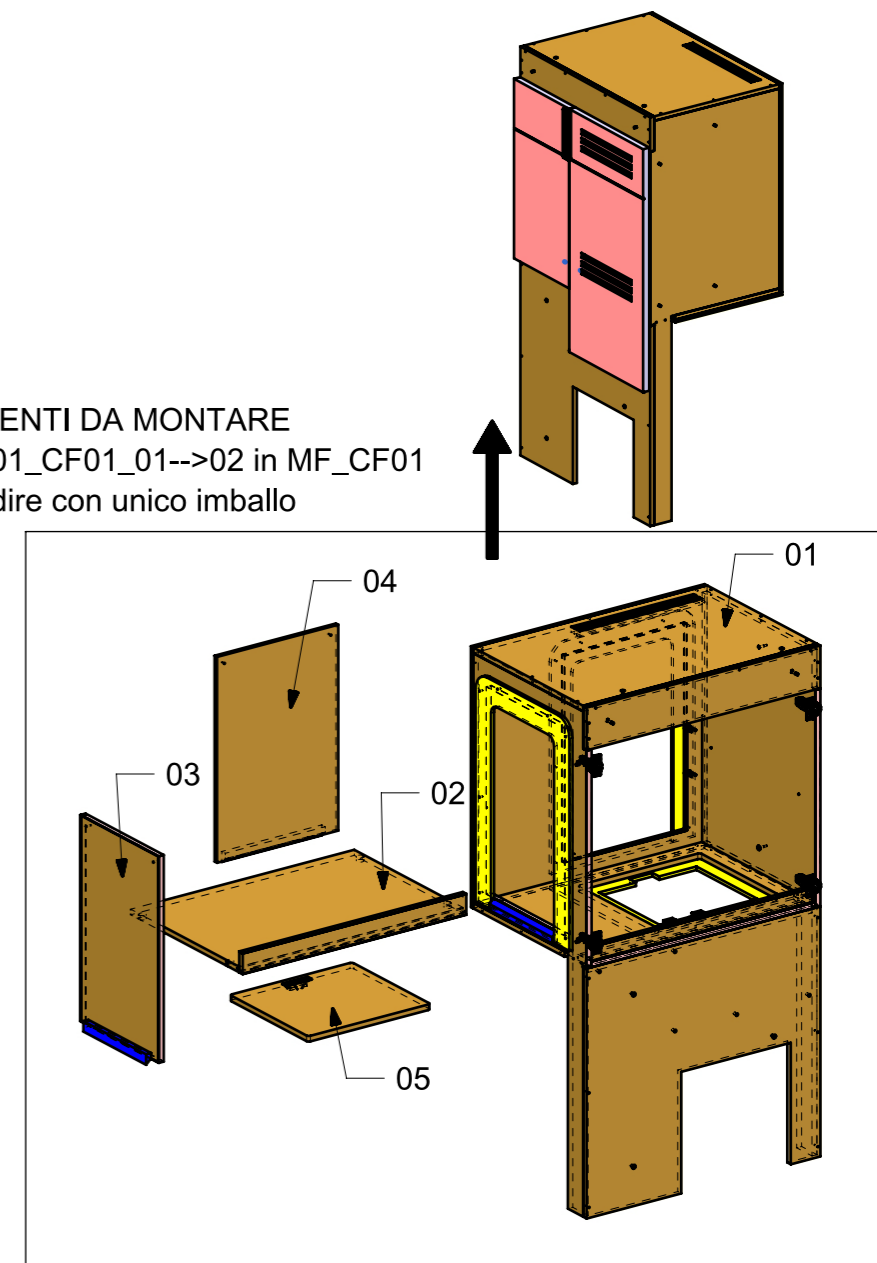

LOCALE	CODICE	DESCRIZIONE COMPONENTE	FINITURA	Q.TA
LOBBY	MD298_CH01	GRADINI GREZZI DISCESA ARMATORE	OKUME' GREZZO	1

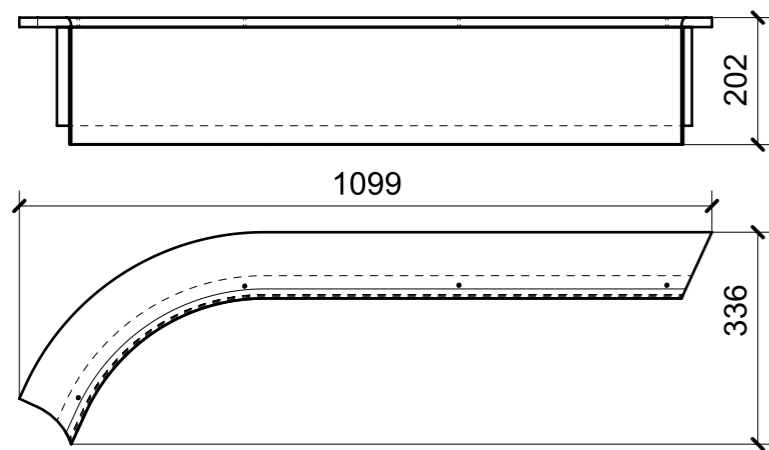

01

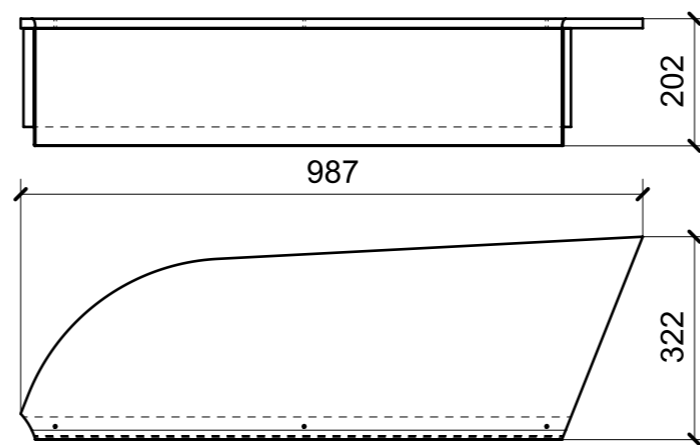

02

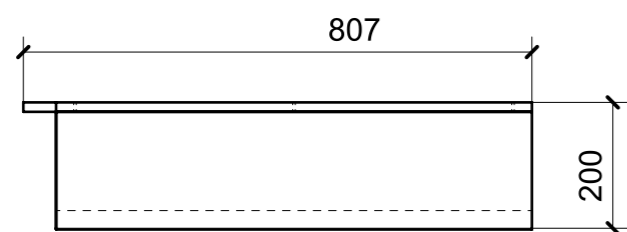

03

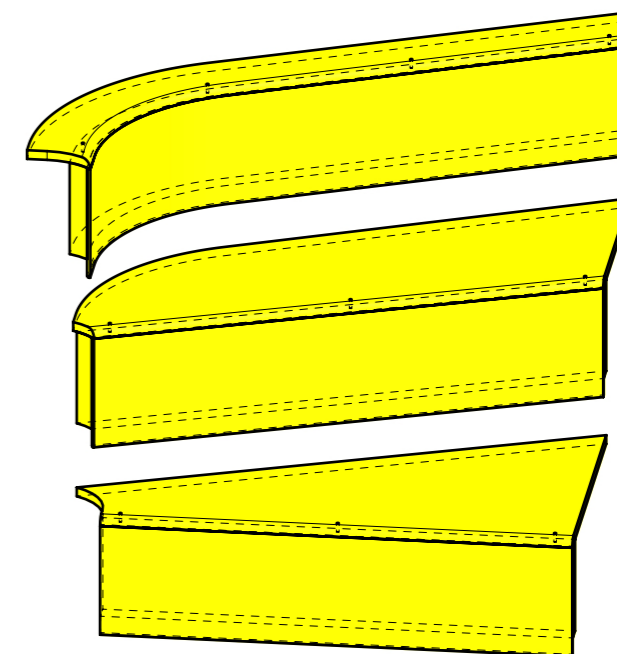

LOCALE	CODICE	DESCRIZIONE COMPONENTE	FINITURA	Q.TA
LOBBY	MD298_CI01	RIV. PARETE SX DISCESA SCALA	OKUME' GREZZO	1

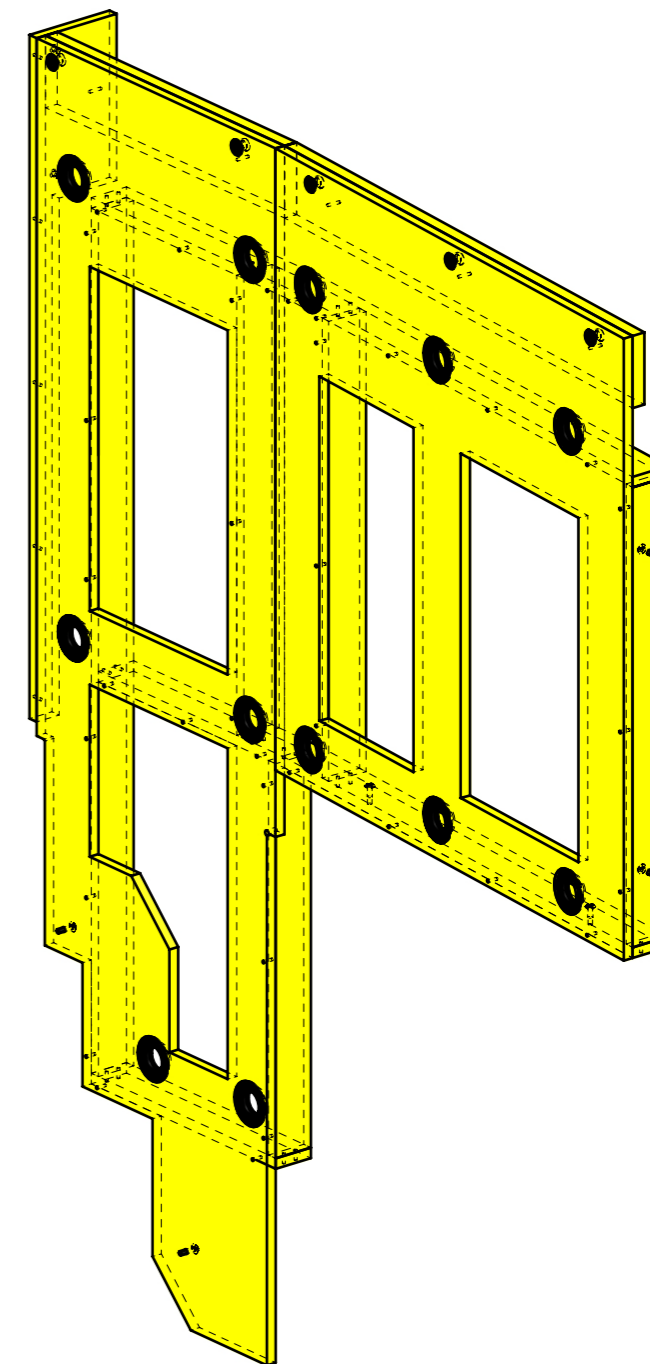
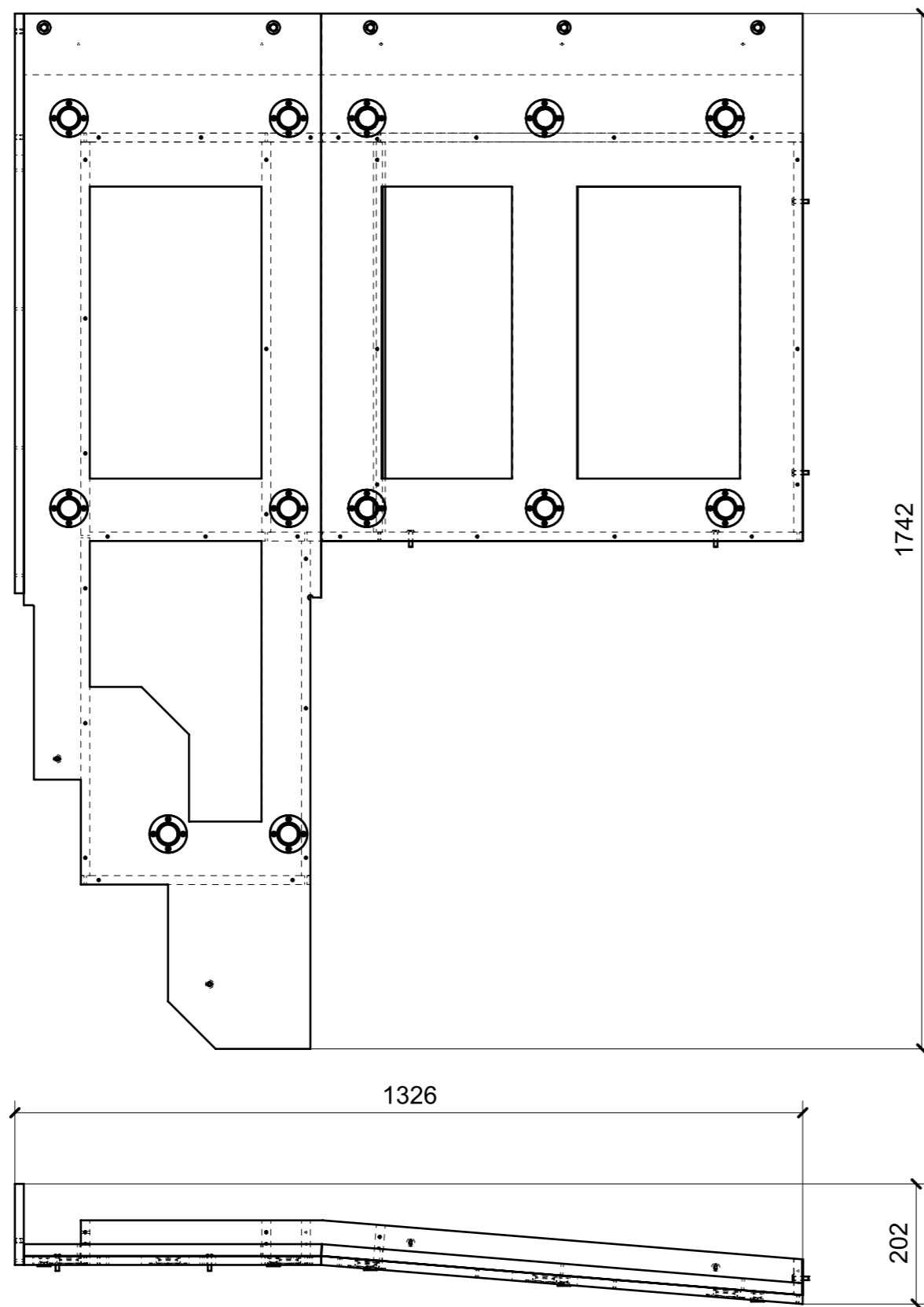

FERRAMENTA	QTY
FM INCASSO_ITALVIPLA_973_FMPC_F1A	5
BUSSOLA 6MA X 10 FORO DIAM.8	2
FITLOCK F_MASCHERPA_6020101102	12
VITE 6MA X 25 TESTA BOMBATA	6

LOCALE	CODICE	DESCRIZIONE COMPONENTE	FINITURA	Q.TA
LOBBY	MD298_CG01	MONTANTE VERTICALE MOBILE SOTTOSCALA	OKUME' GREZZO	1

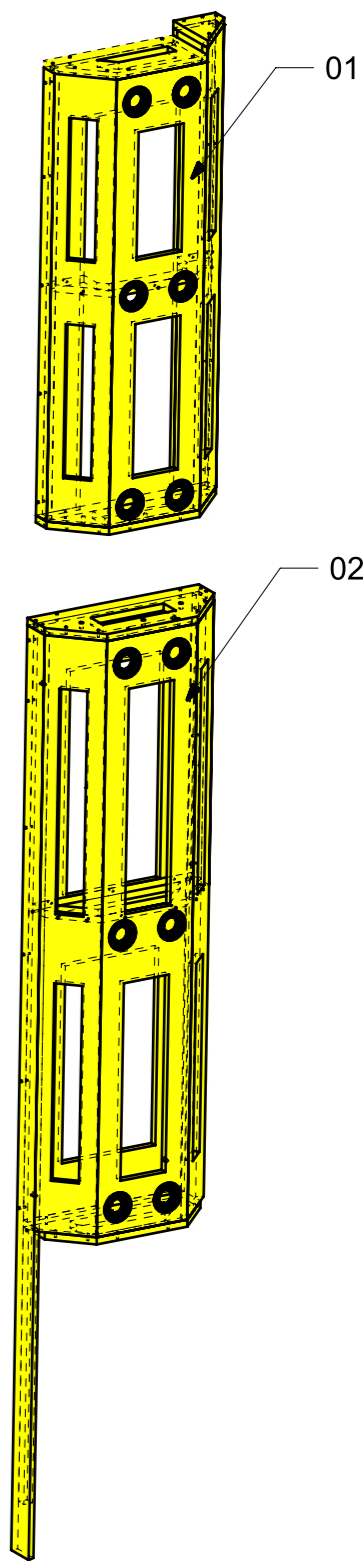
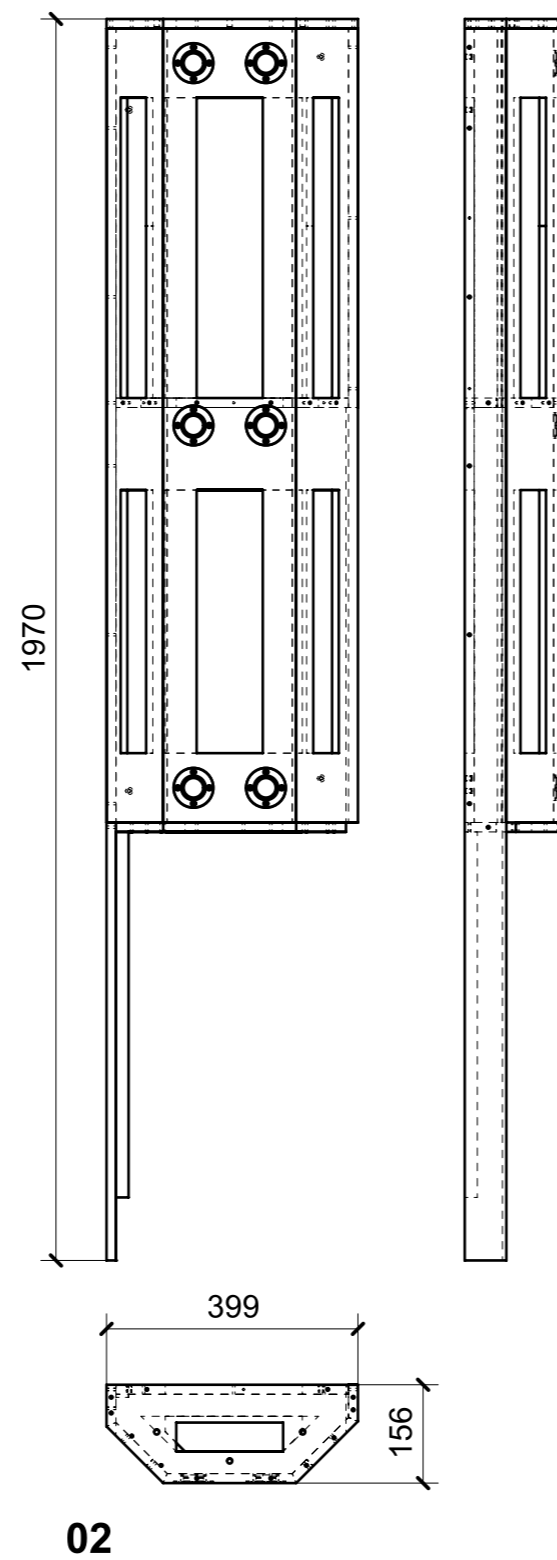
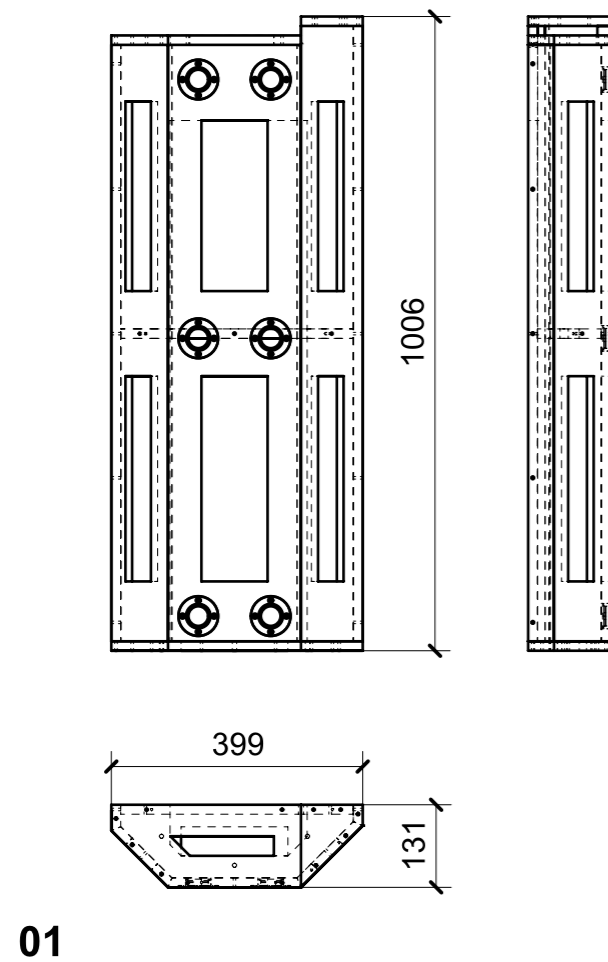

FERRAMENTA	QTY
FITLOCK F_MASCHERPA_6020101102	12
BUSSOLA 5MA X 10 FORO DIAM.8	4

LOCALE	CODICE	DESCRIZIONE COMPONENTE	FINITURA	Q.TA
LOBBY	MD298_CL01	RIV. PARETE DX DISCESA SCALA	OKUME' GREZZO	1

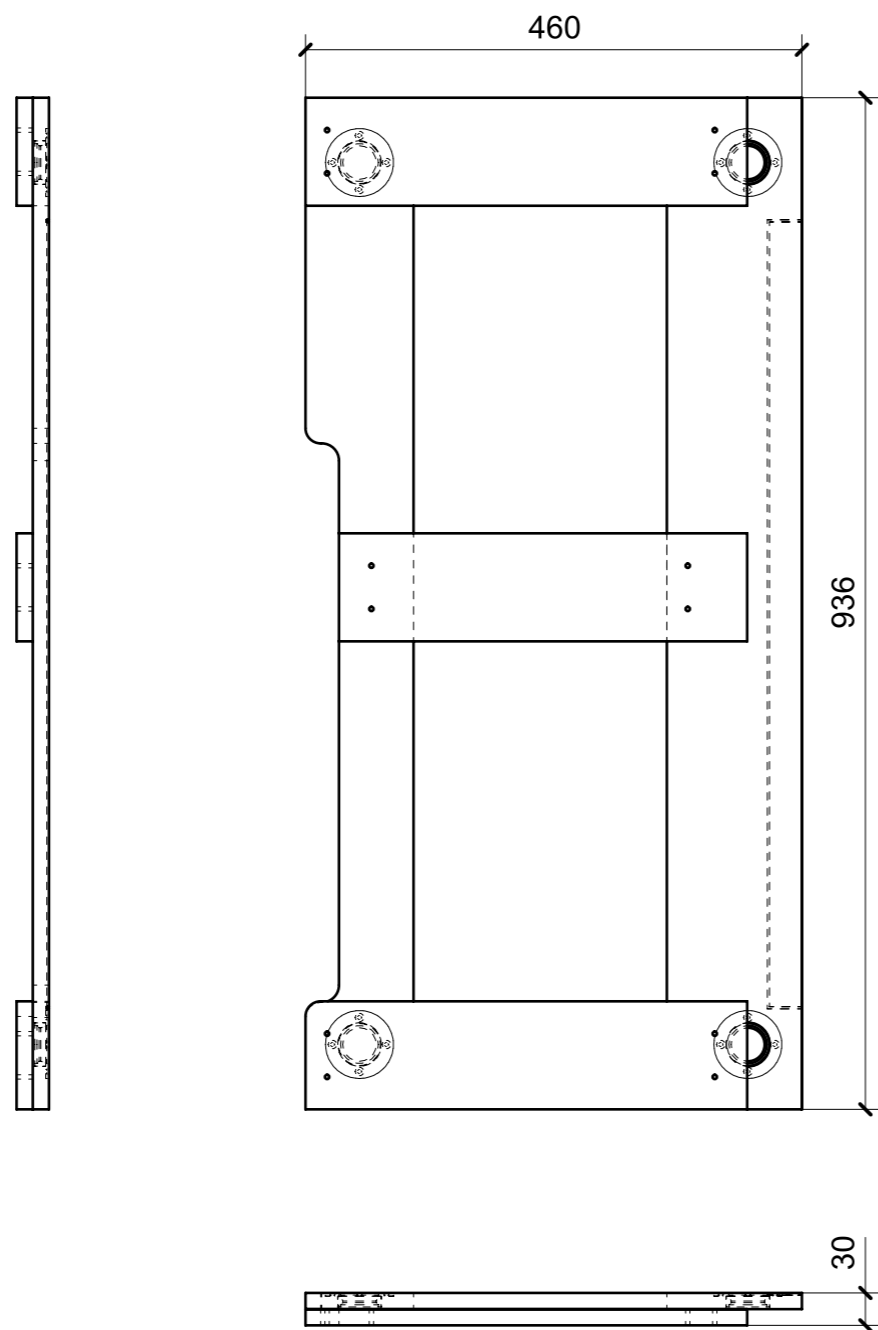

ELEMENTO DA MONTARE
con A05_CL01_01 in MF_CL01
e spedire con unico imballo

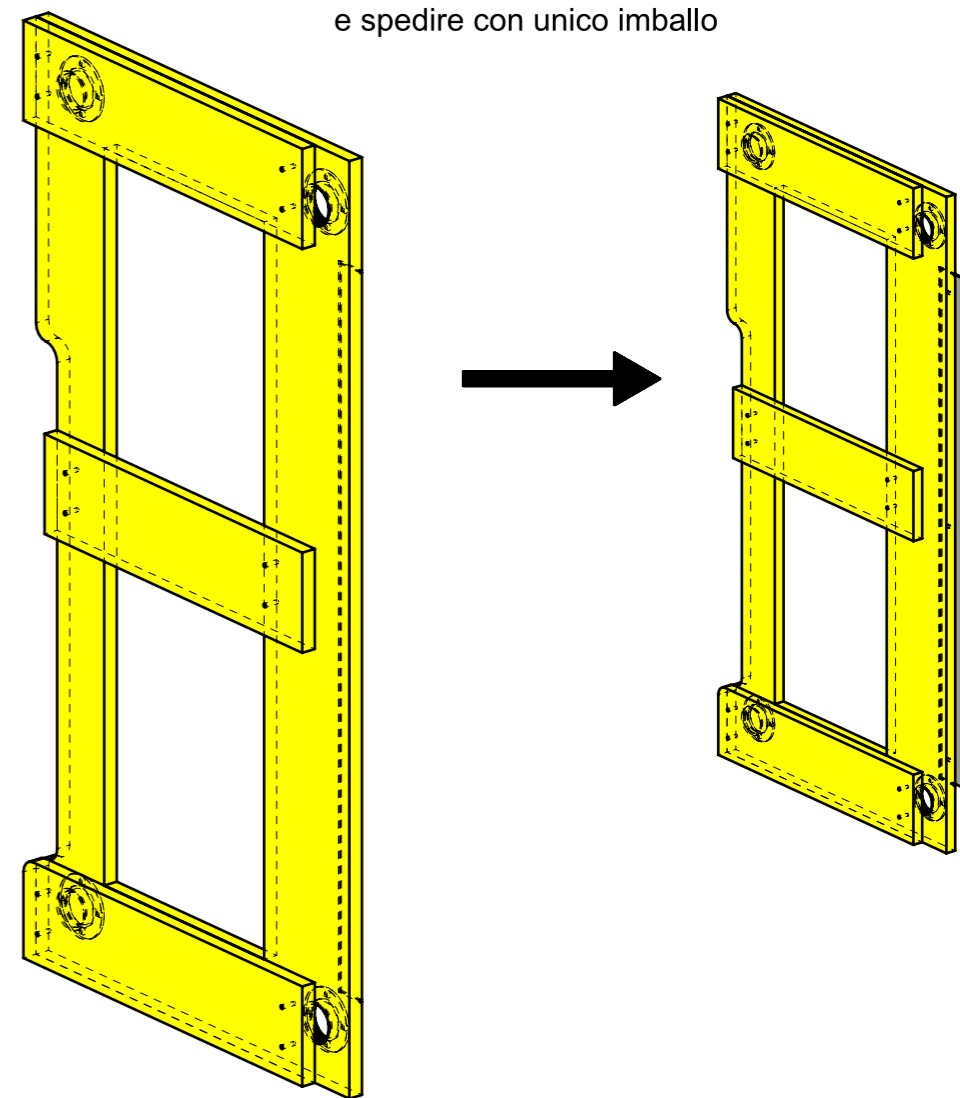

FERRAMENTA	QTY
FITLOCK F_MASCHERPA_6020101102	4

LOCALE	CODICE	DESCRIZIONE COMPONENTE	FINITURA	Q.TA
LOBBY	MD298_CCF01	MOBILE WINE COOLER_OPT	LAMINATO LG23 PORO ROVERE	1

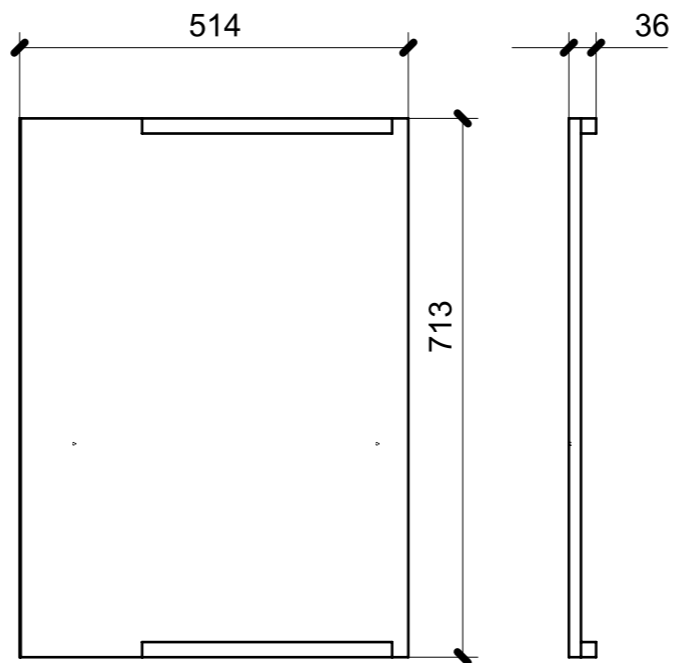
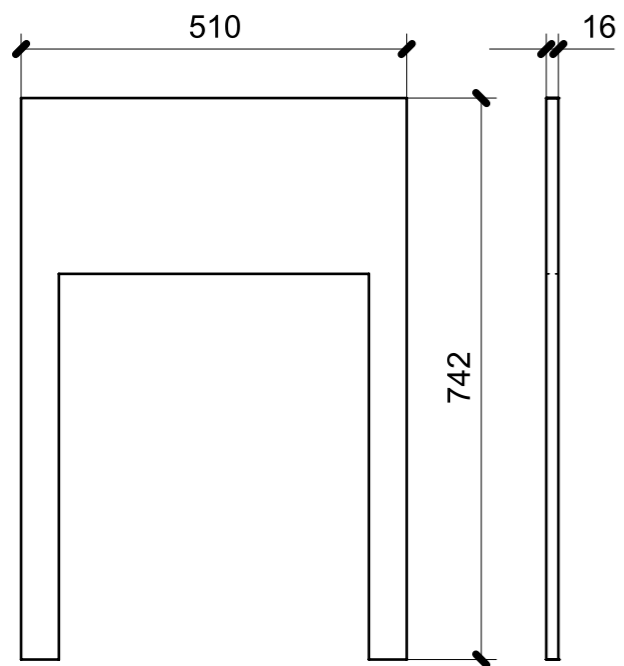

01

02

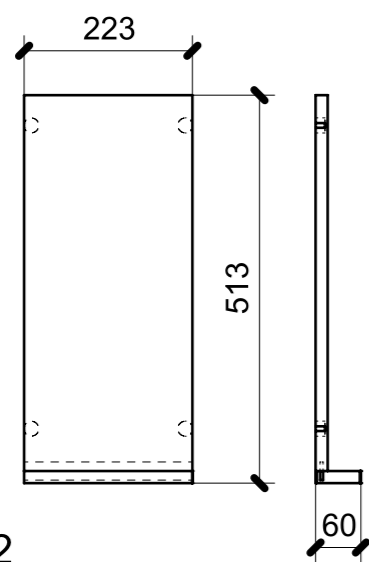

02

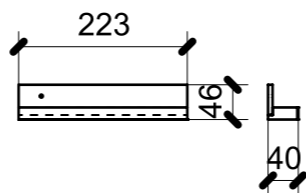

04

