

LOCALE	CODICE	DESCRIZIONE COMPONENTE	FINITURA	Q.TA
SALONE	MD298_I01_SA01	MONTANTE CENTRALE DX	OKUME' GREZZO	1

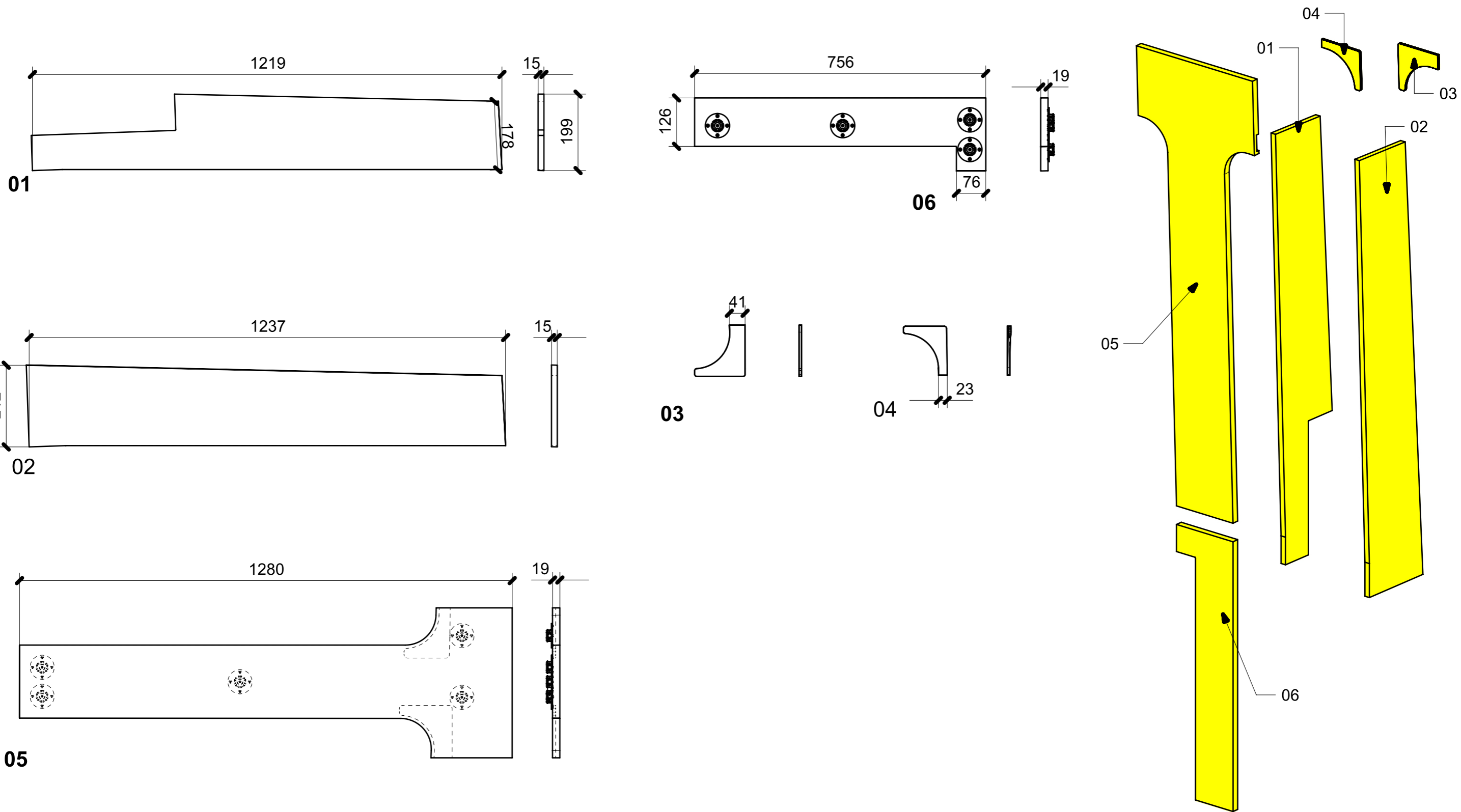

FERRAMENTA	QTY
FITLOCK M_MASCHERPA_3MM_6020202101	9

LOCALE	CODICE	DESCRIZIONE COMPONENTE	FINITURA	GR
SALONE	MD298_I01_SC01	MANTOVANA MURATA DX	OKUME' GREZZO	5

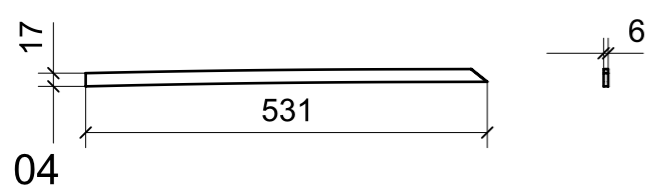
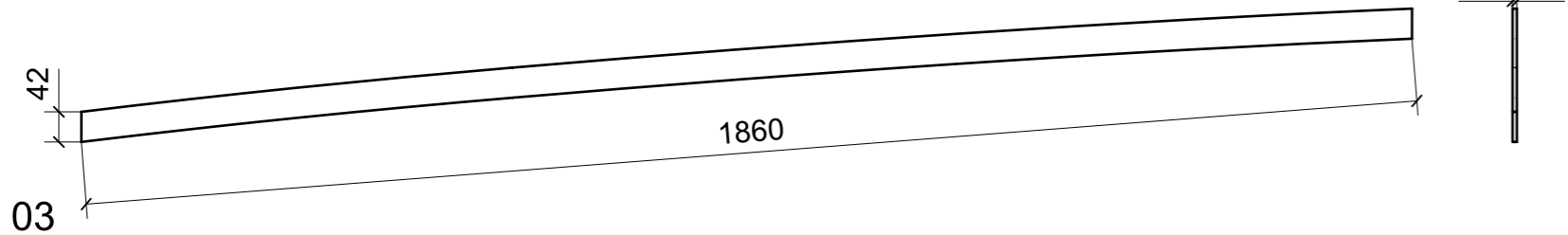
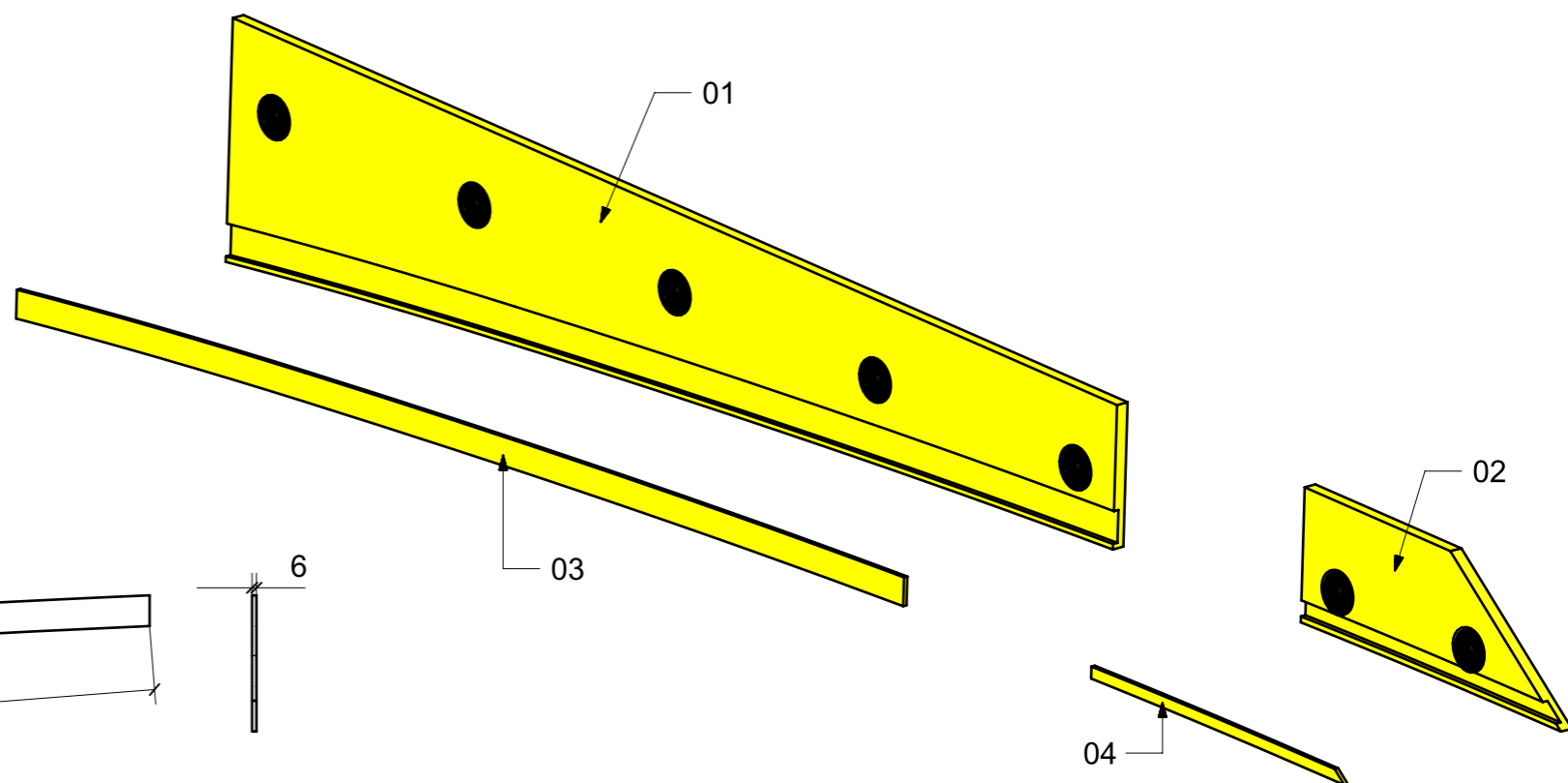
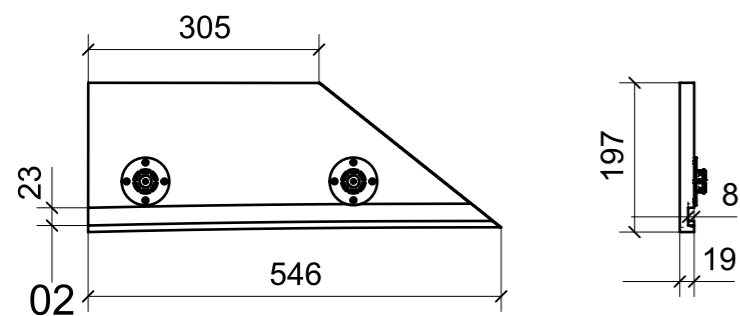
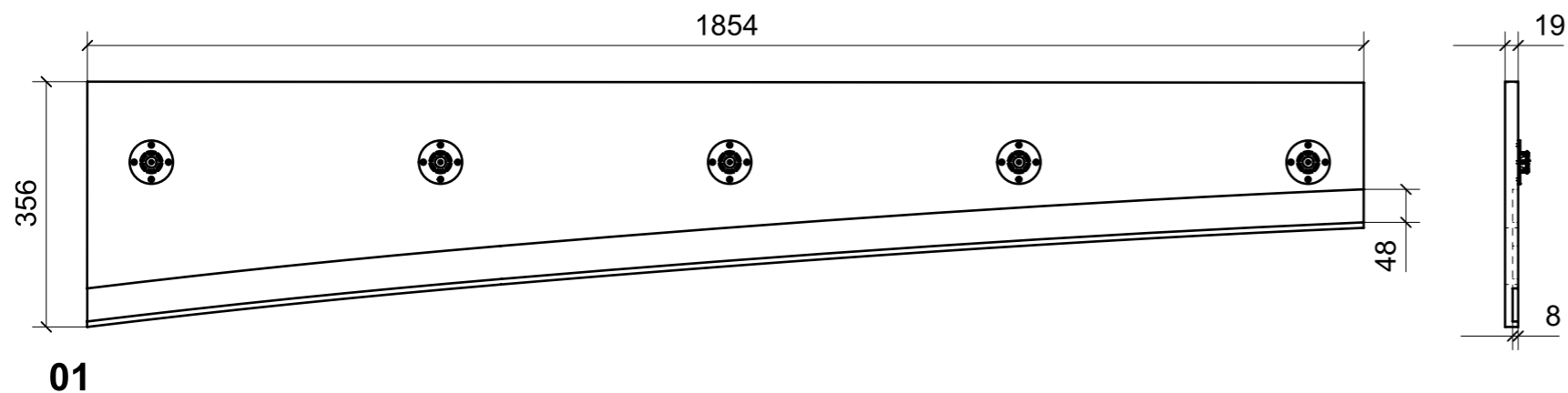

FERRAMENTA	QTY
FITLOCK M_MASCHERPA_3MM_6020202101	7

LOCALE	CODICE	DESCRIZIONE COMPONENTE	FINITURA	Q.TA
SALONE	MD298_I01_SD01	COLONNA SX DI POPPA	OKUME' GREZZO	1

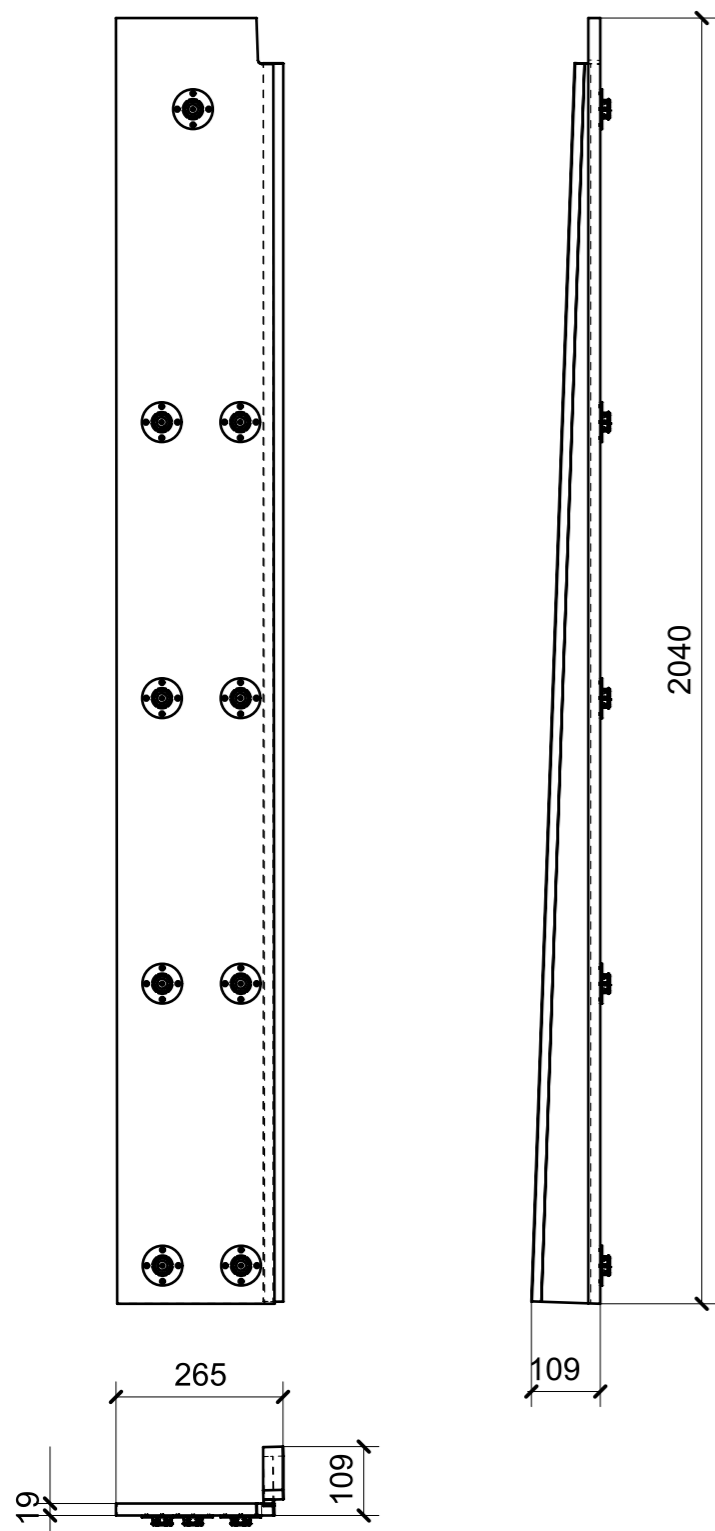

01

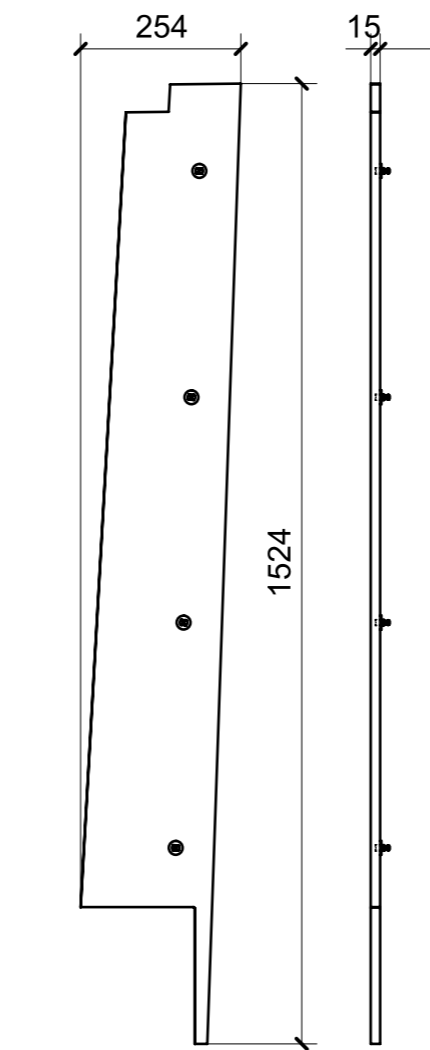

02

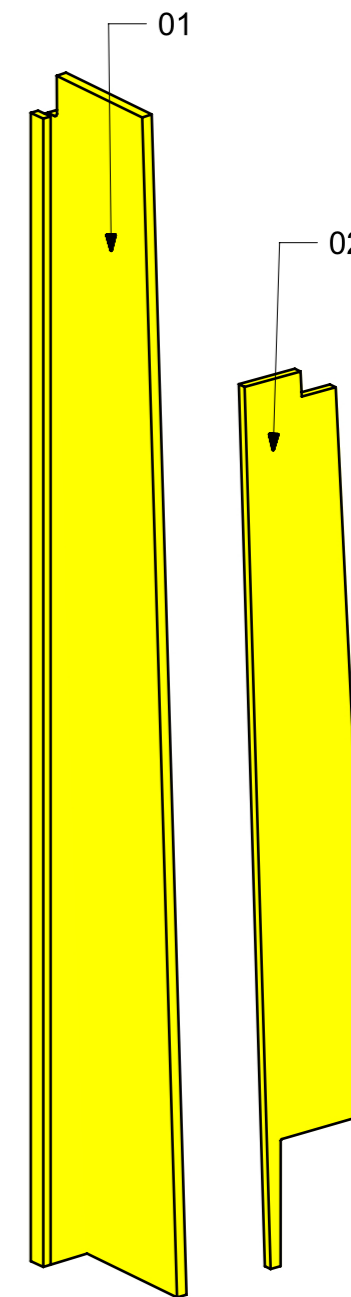

FERRAMENTA	QTY
FITLOCK M_MASCHERPA_3MM_6020202101	9
MS INCASSO_ITALVIPLA_972_FMPC_M1B	4

LOCALE	CODICE	DESCRIZIONE COMPONENTE	FINITURA	Q.TA
SALONE	MD298_I01_SE01	MURATA SX DI POPPA	OKUME' GREZZO	1

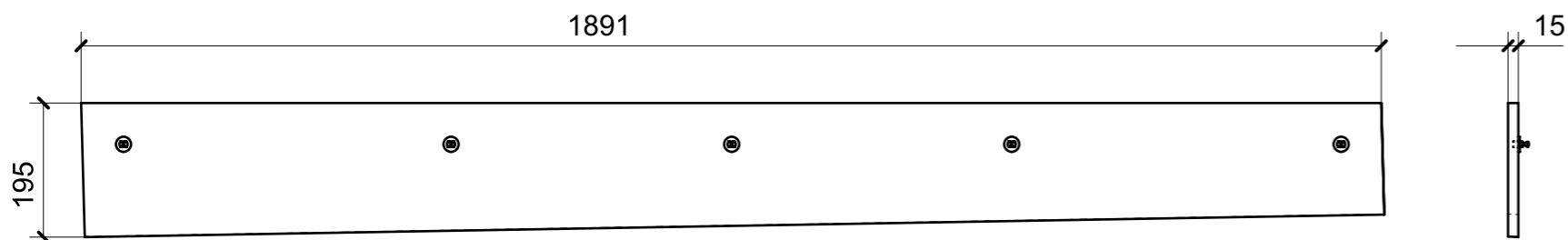

01

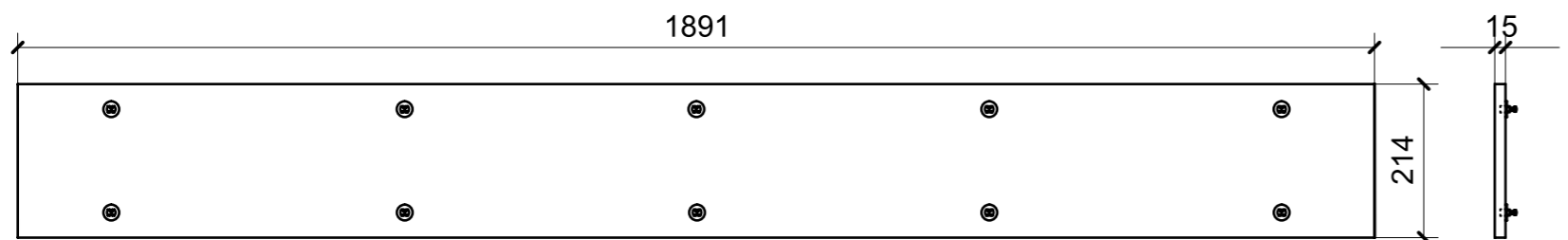

02

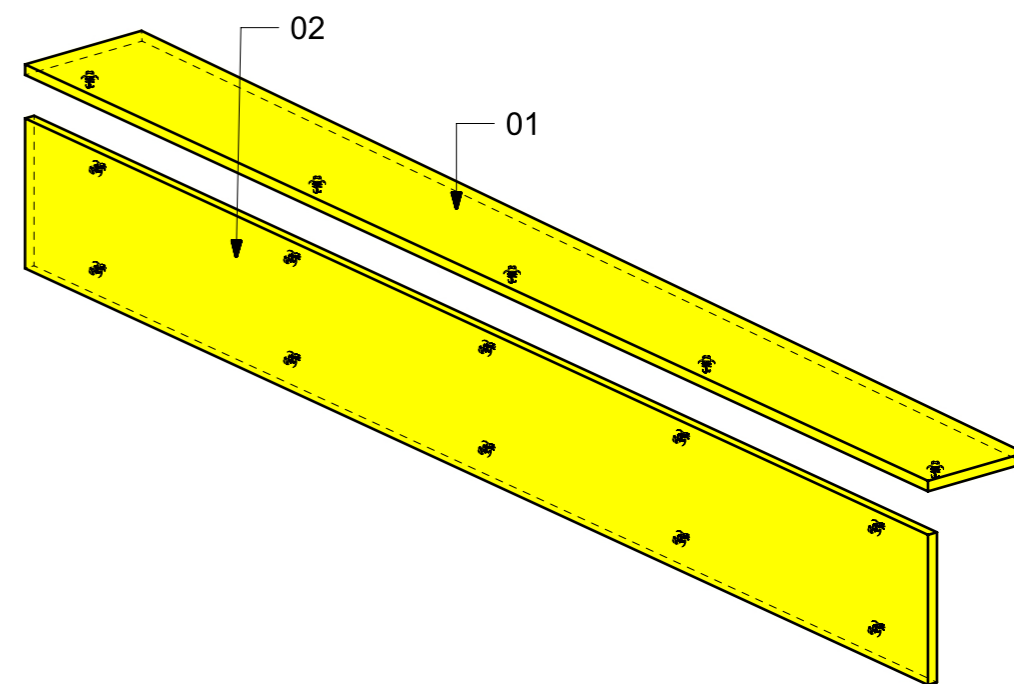

FERRAMENTA	QTY
MS INCASSO_ITALVIPLA_972_FMPC_M1B	15

LOCALE	CODICE	DESCRIZIONE COMPONENTE	FINITURA	Q.TA
SALONE	MD298_I01_SF01	MANTOVANA SX DI POPPA	OKUME' GREZZO	1

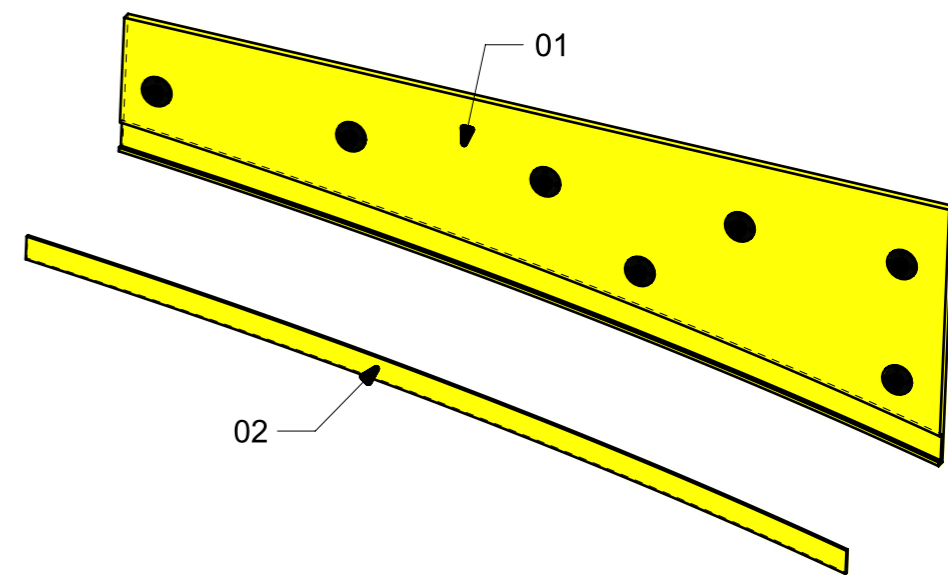
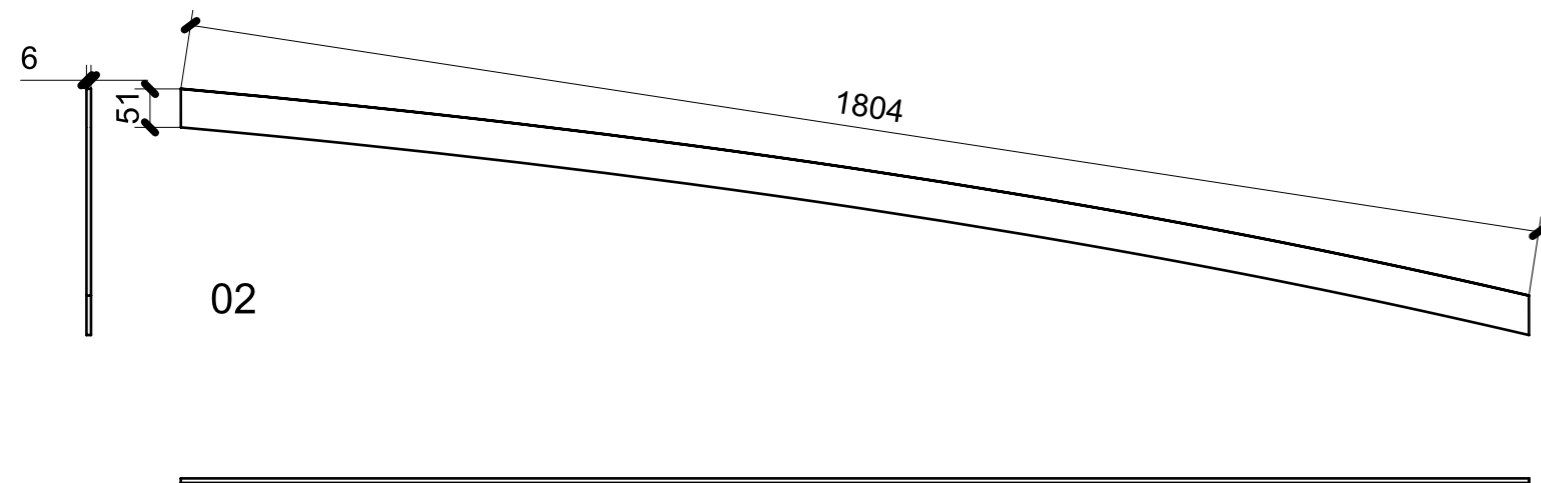
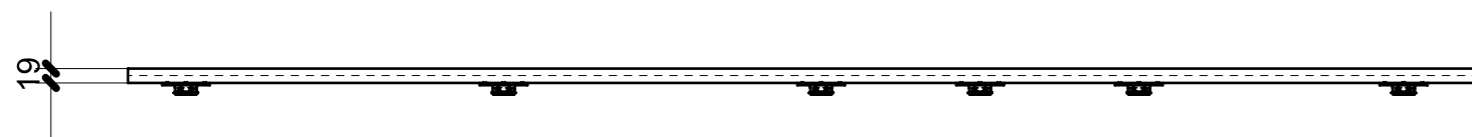
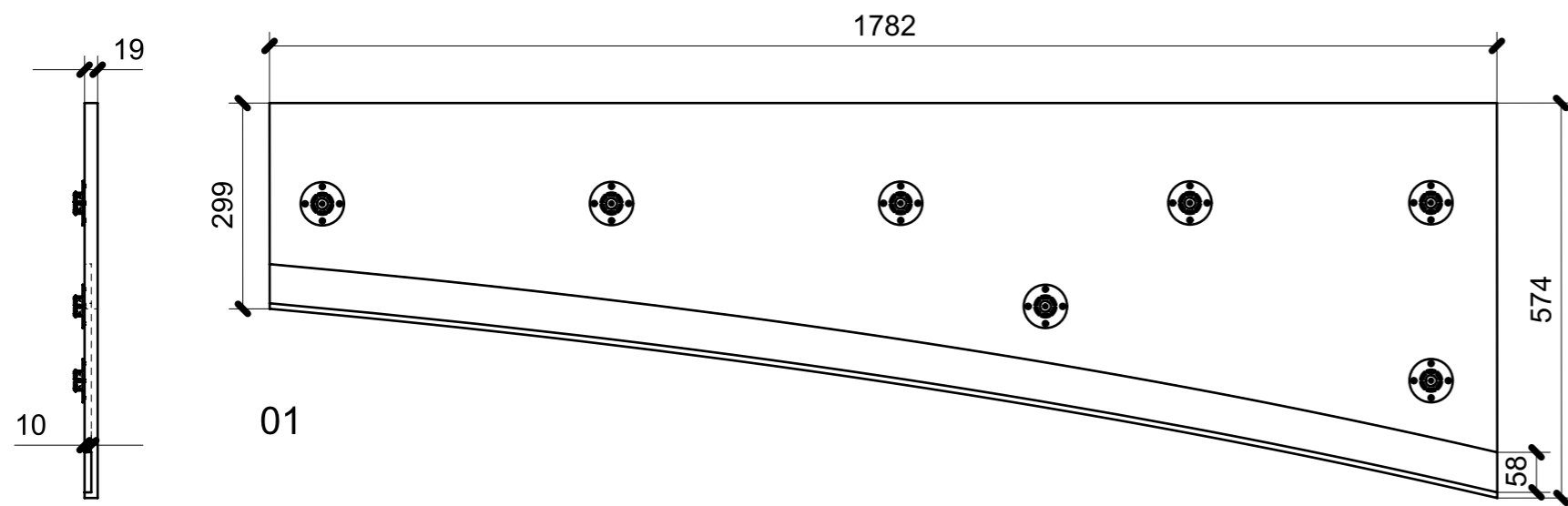

FERRAMENTA	QTY
FITLOCK M_MASCHERPA_3MM_6020202101	7

LOCALE	CODICE	DESCRIZIONE COMPONENTE	FINITURA	Q.TA
SALONE	MD298_I01_SG01	MURATA SX DI PRUA	OKUME' GREZZO	1

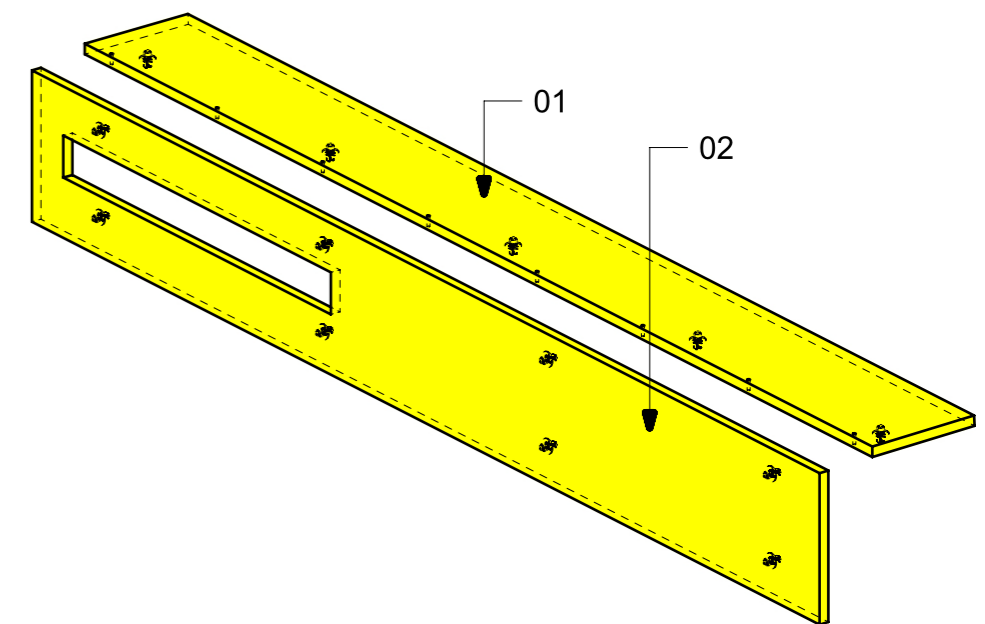
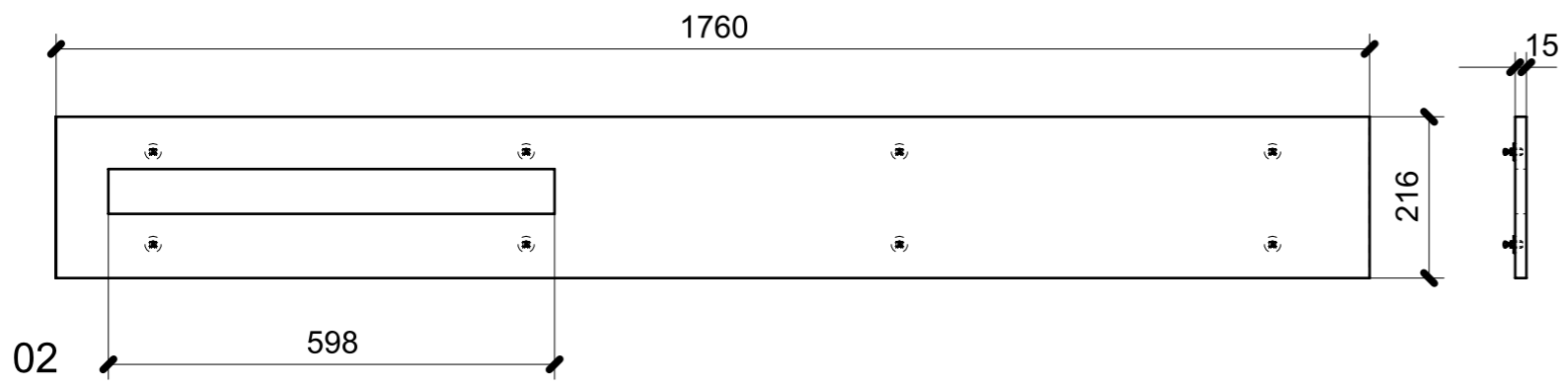
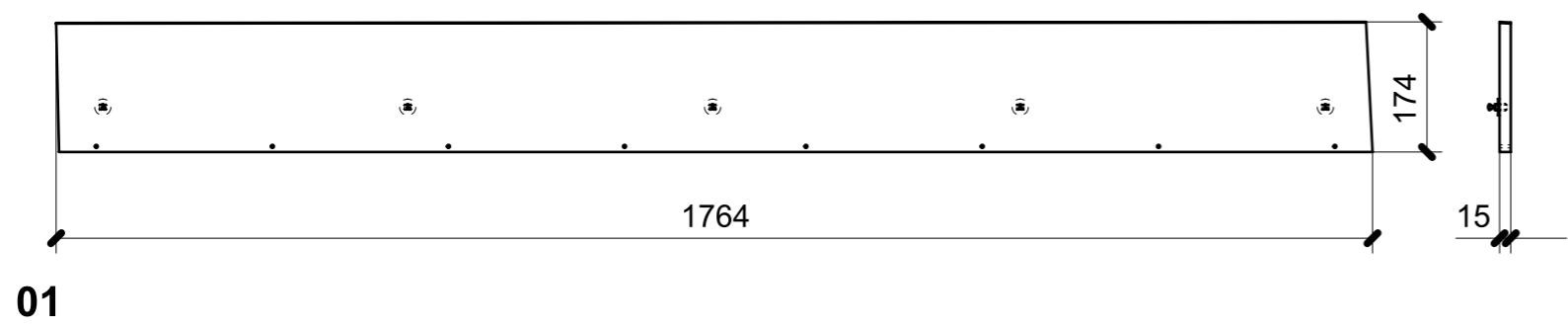

FERRAMENTA	QTY
MS INCASSO_ITALVIPLA_972_FMPC_M1B	13

LOCALE	CODICE	DESCRIZIONE COMPONENTE	FINITURA	Q.TA
SALONE	MD298_I01_SH01	MONTANTE CENTRALE SX	OKUME' GREZZO	1

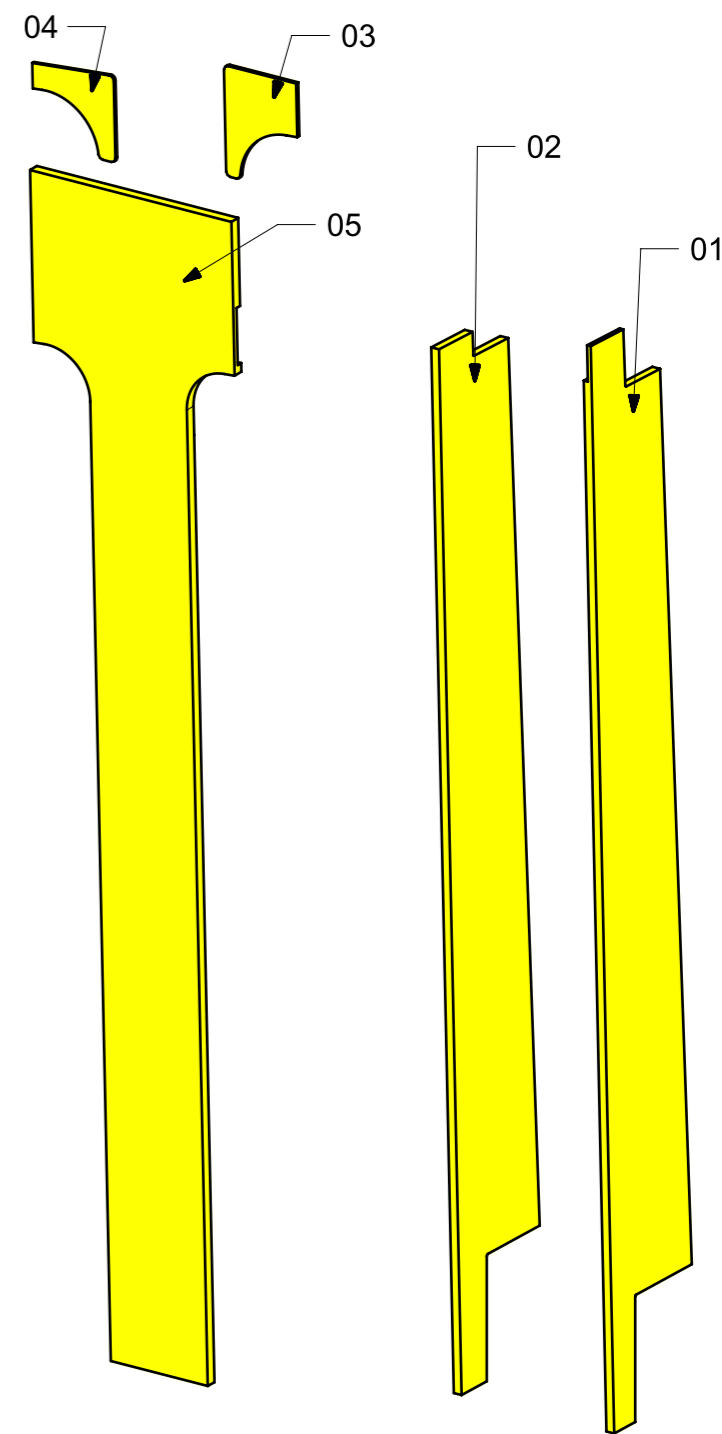
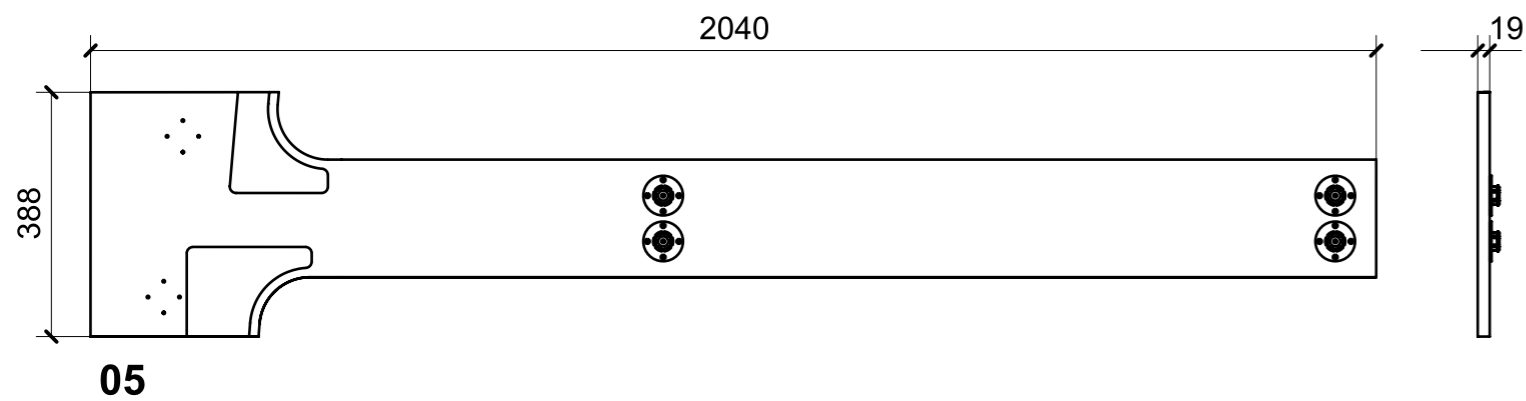
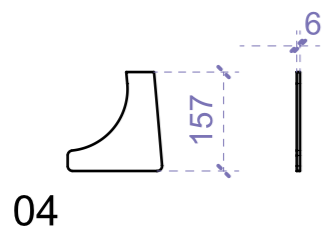
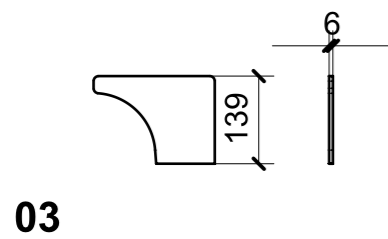
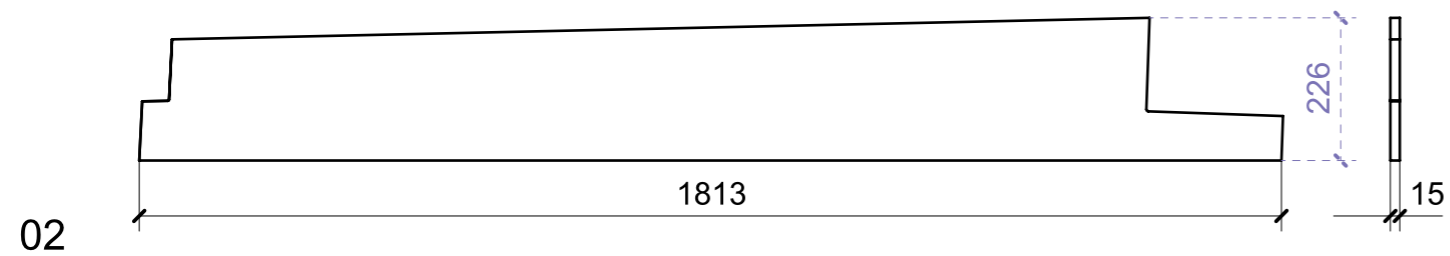
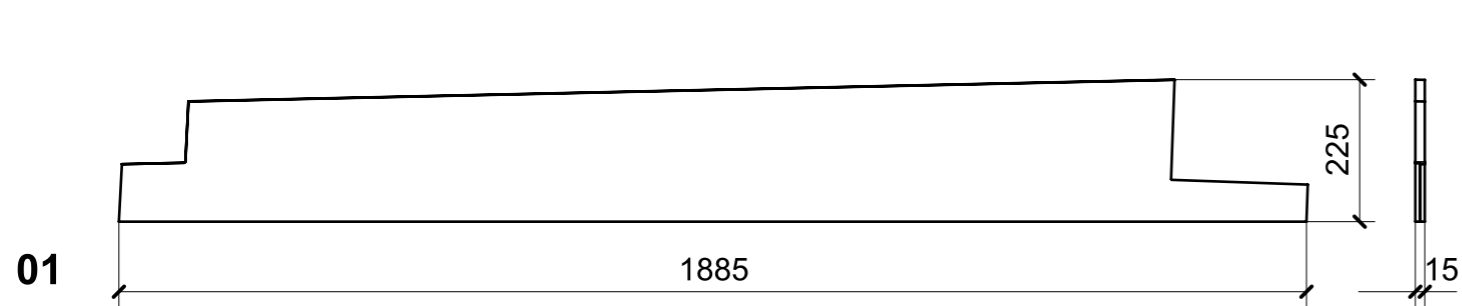

FERRAMENTA	QTY
FITLOCK M_MASCHERPA_3MM_6020202101	4

LOCALE	CODICE	DESCRIZIONE COMPONENTE	FINITURA	GR
SALONE	MD298_I01_SI01	MANTOVANA SX DI PRUA	OKUME' GREZZO	5

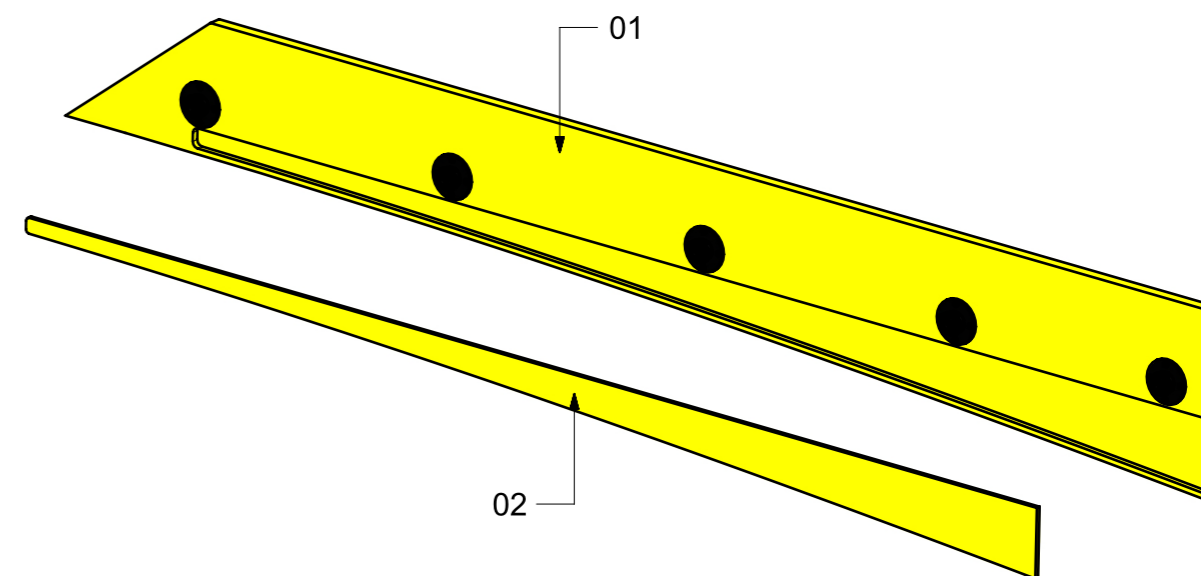
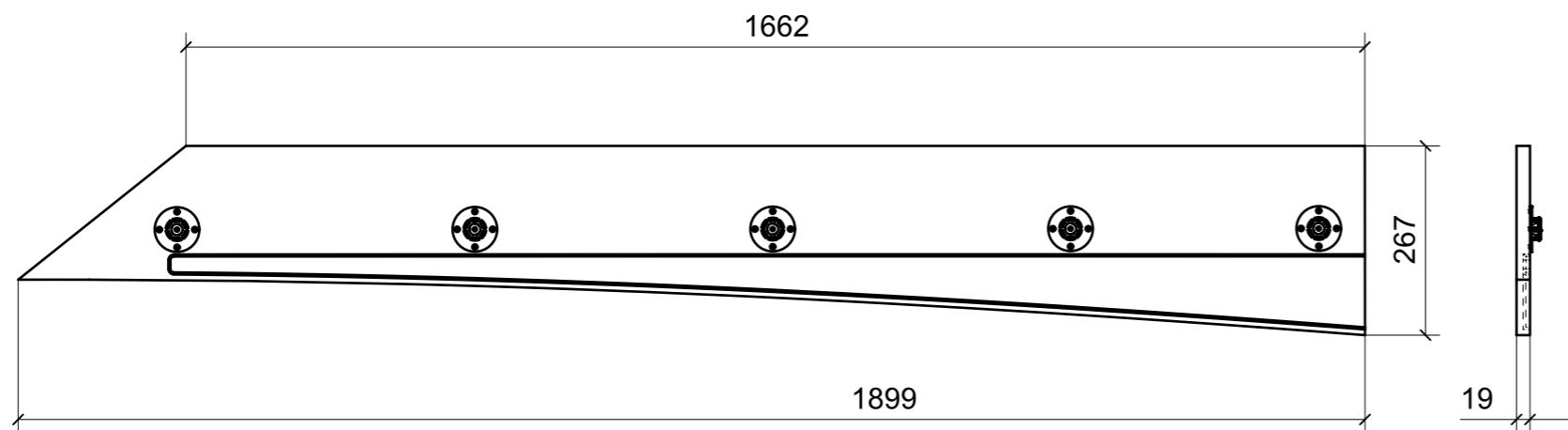

FERRAMENTA	QTY
FITLOCK M_MASCHERPA_3MM_6020202101	5

LOCALE	CODICE	DESCRIZIONE COMPONENTE	FINITURA	Q.TA
SALONE	MD298_I01_SL01	MONTANTE SX DI PRUA	OKUME' GREZZO	1

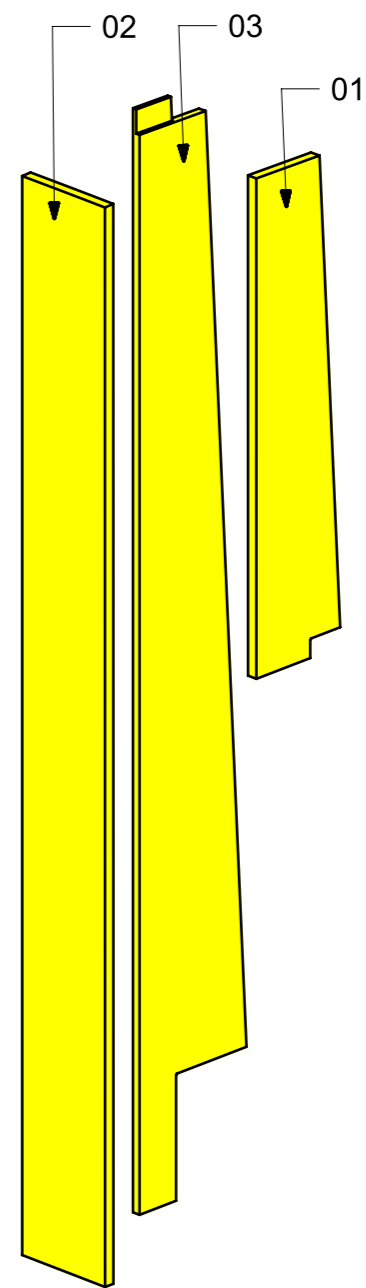
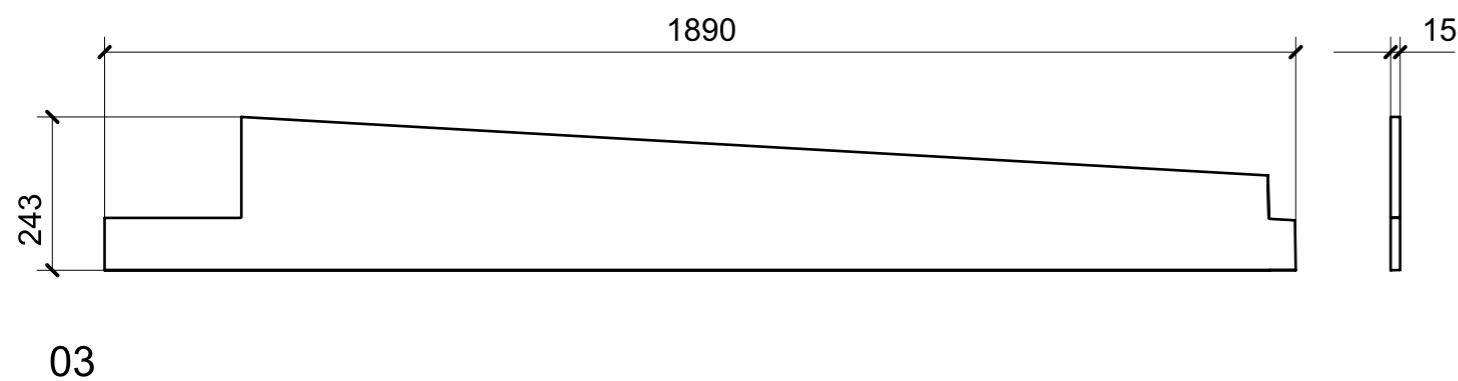
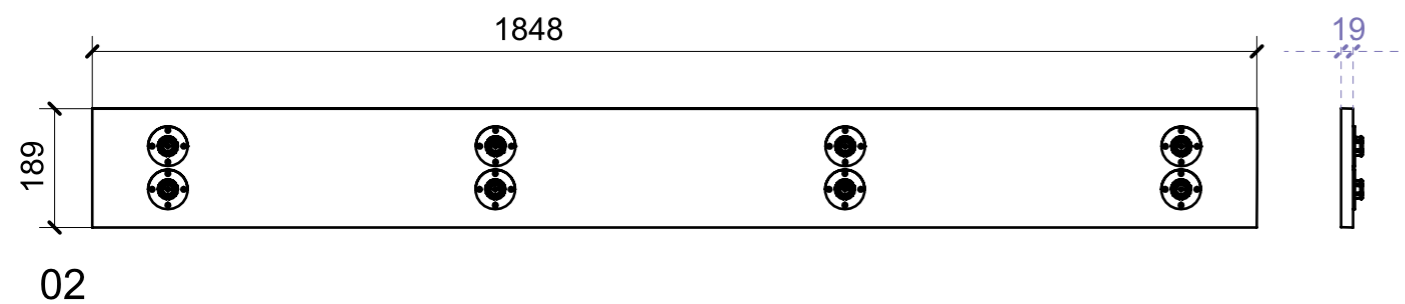
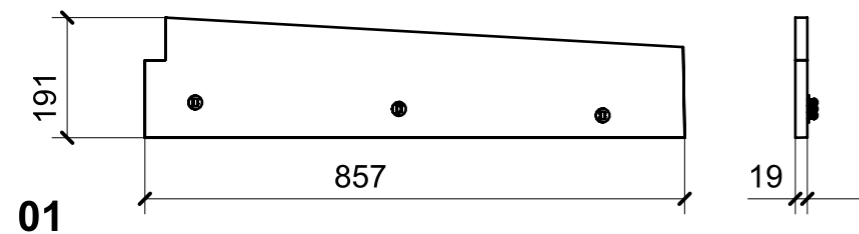

FERRAMENTA	QTY
FITLOCK M_MASCHERPA_3MM_6020202101	8
MS INCASSO_ITALVIPLA_972_FMPC_M1B	3

LOCALE	CODICE	DESCRIZIONE COMPONENTE	FINITURA	Q.TA
SALONE	MD298_I01_SO01	PANNELLI SOTTO CARTER PARABREZZA	OKUME' GREZZO	1

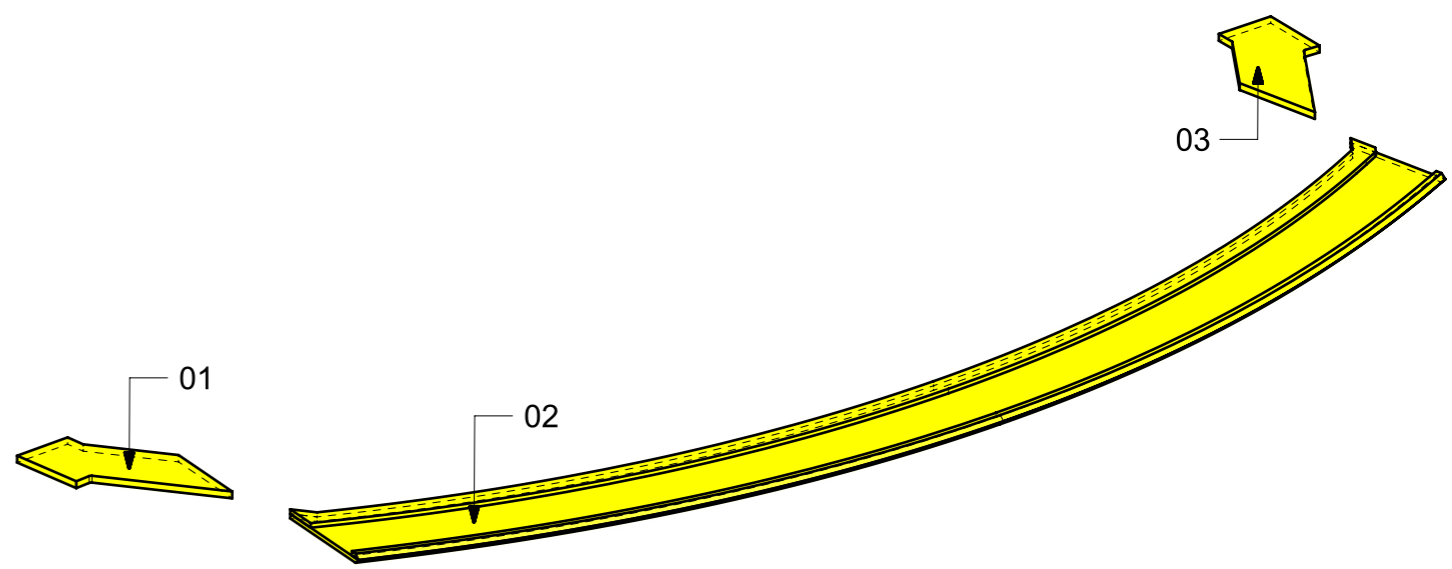
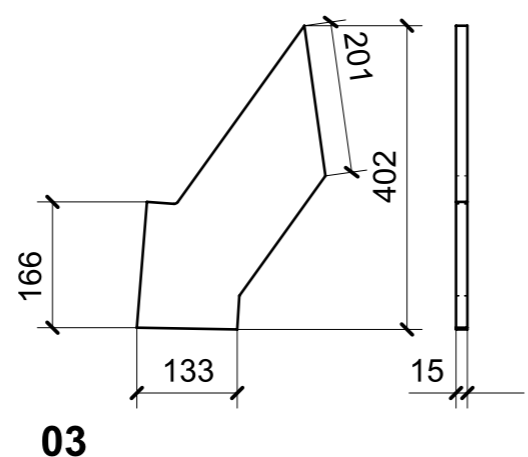
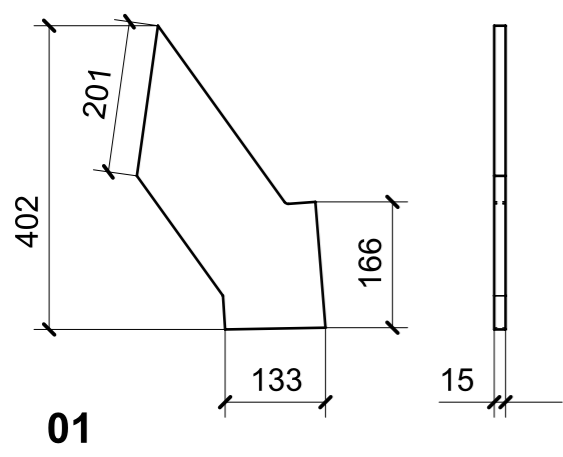
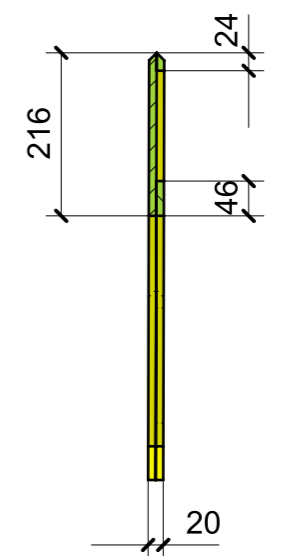
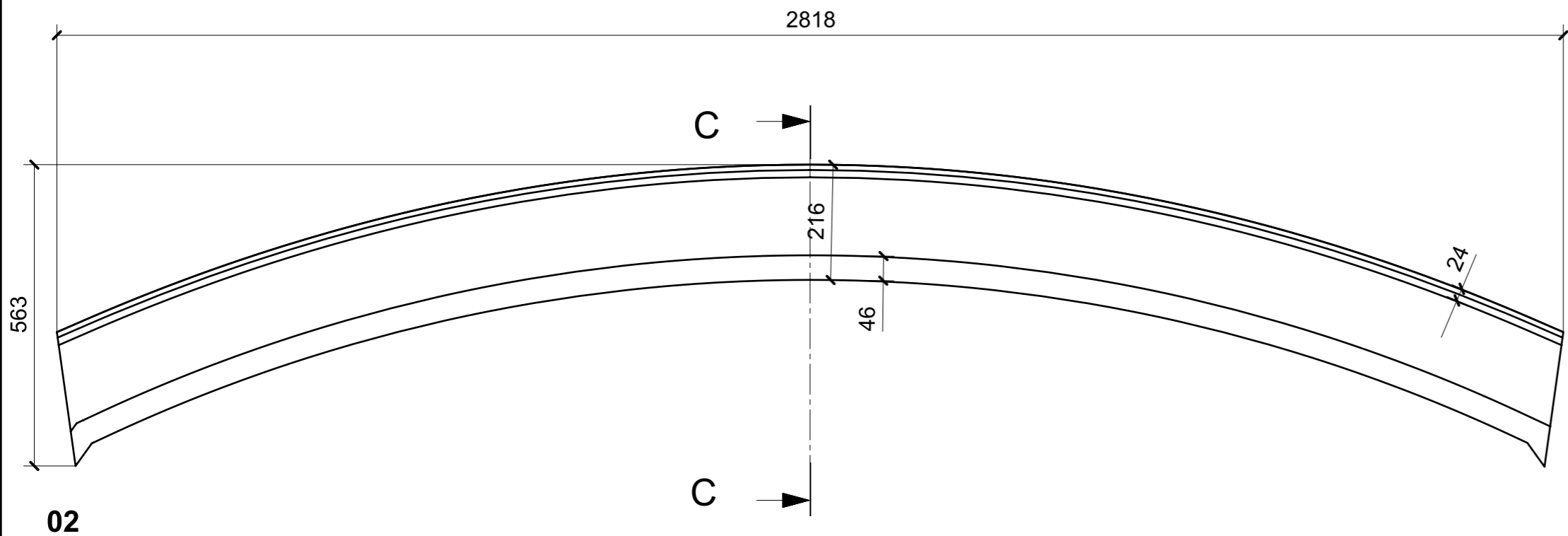

LOCALE	CODICE	DESCRIZIONE COMPONENTE	FINITURA	Q.TA
SALONE	MD298_I01_SP01	TAVOLO SALONE STD	OKUME' GREZZO	1

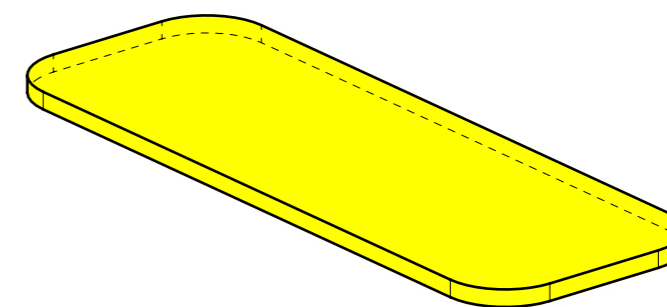
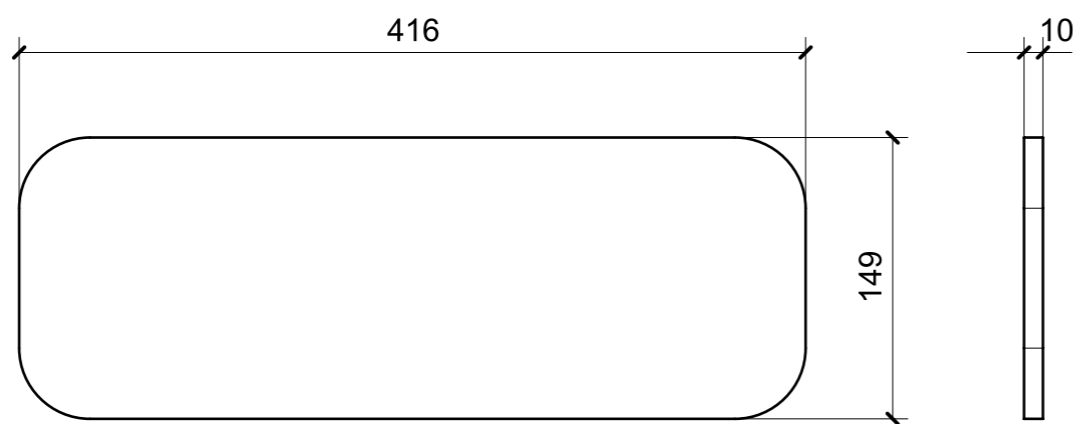

ELEMENTO DA MONTARE
con A36-A37-A38; R01_SP01_01-->03
in MF_SP01
e spedire con unico imballo

