

LOCALE	CODICE	DESCRIZIONE COMPONENTE	FINITURA	GR
CABINA VIP	MD298_A01_VA01	LETTO	ACCIAIO GREZZO	8

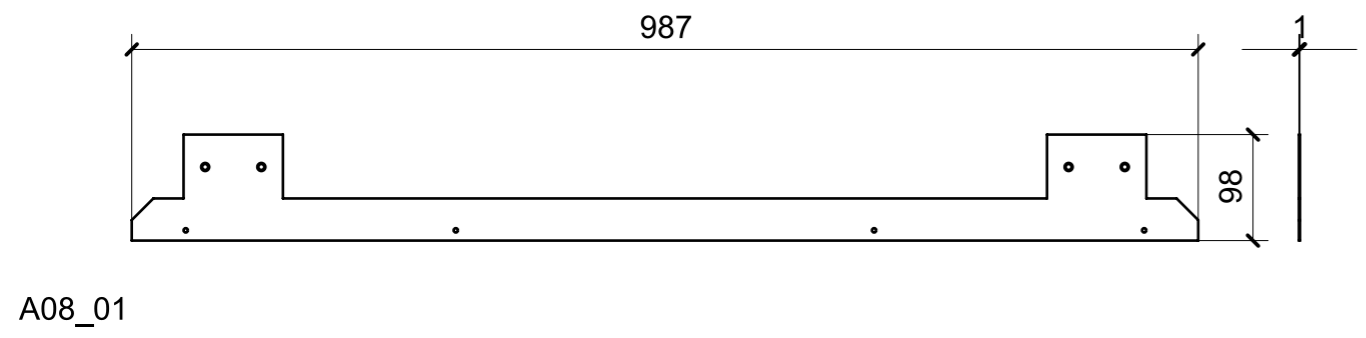

ELEMENTI DA MONTARE con  
VA01\_06 in MF\_VA01  
e spedire con unico imballo

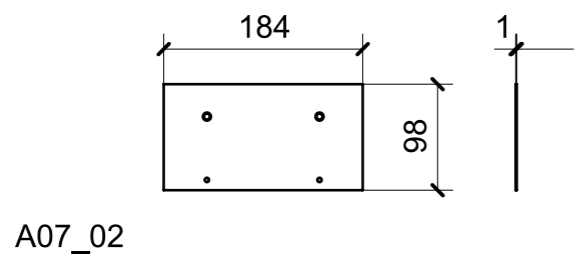
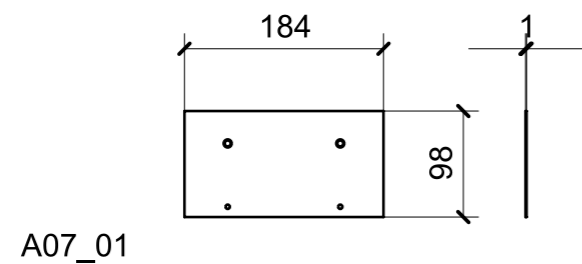
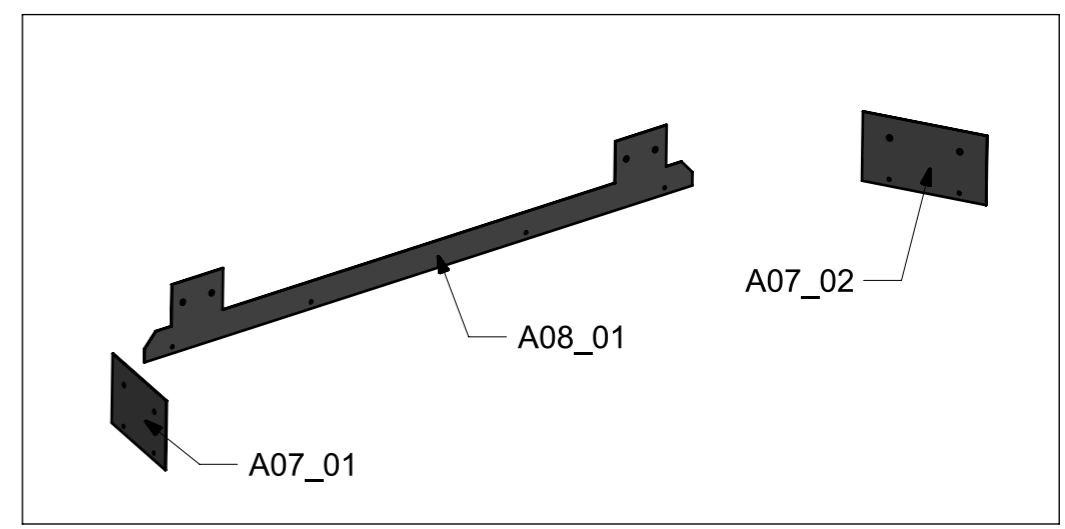
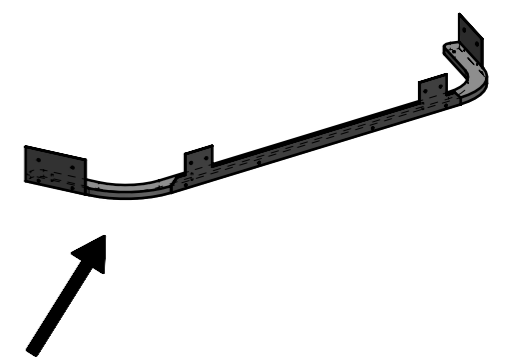

LOCALE	CODICE	DESCRIZIONE COMPONENTE	FINITURA	GR.
CABINA VIP	MD298_A01_VF01	ARMADIO SX	ACCIAIO GREZZO	5

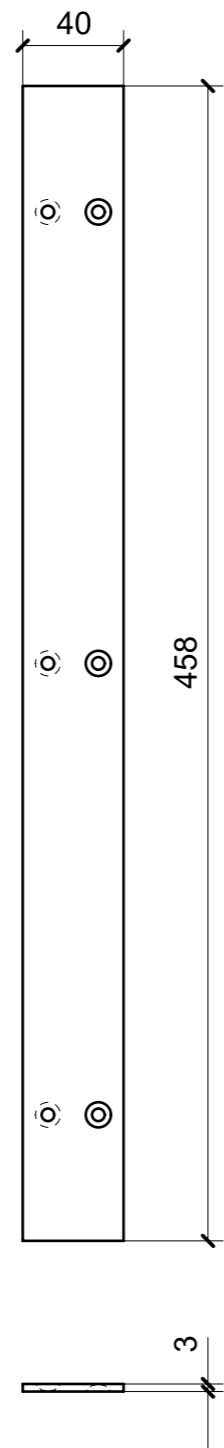

A09\_VF01\_01

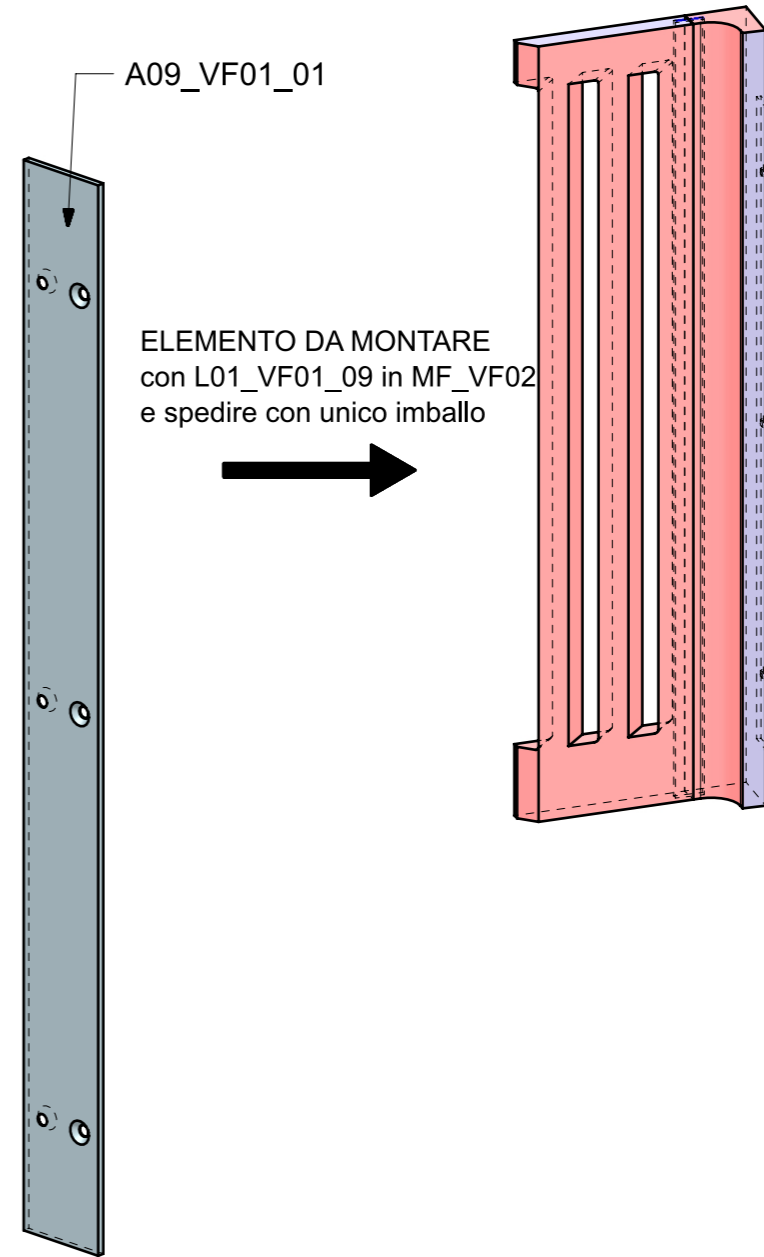

LOCALE	CODICE	DESCRIZIONE COMPONENTE	FINITURA	Q.TA
CABINA VIP	MD298_A01_VG01	ARMADIO DX	ACCIAIO GREZZO	1

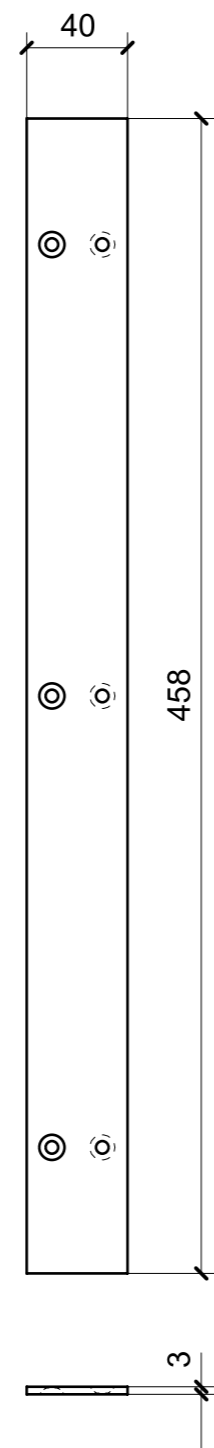

ELEMENTO DA MONTARE  
in MF\_VG02  
e spedire con unico imballo

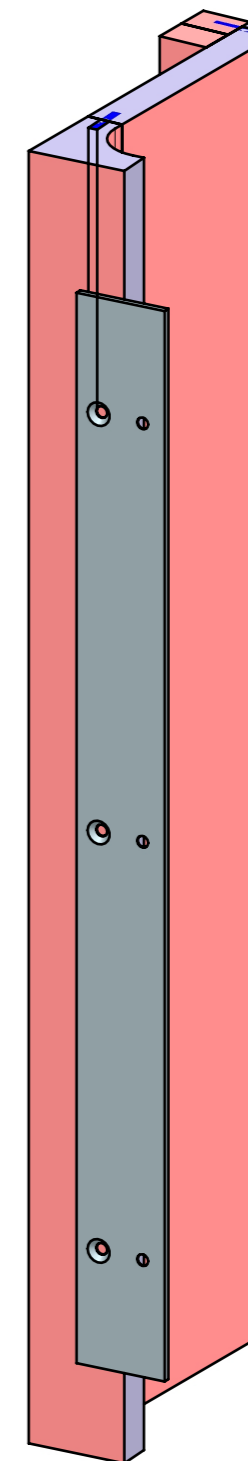

LOCALE	CODICE	DESCRIZIONE COMPONENTE	FINITURA	Q.TA
CABINA VIP	MD298_A01_VH01	COLLEGAMENTO ALTO	ACCIAIO GREZZO	1

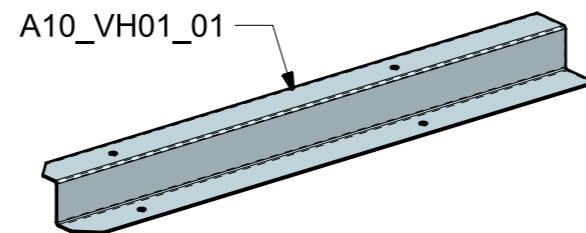
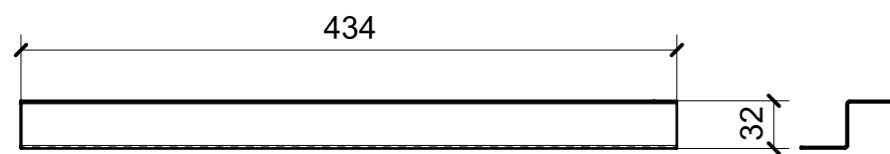

ELEMENTO DA MONTARE  
con VH01\_01 in MF\_VH01  
e spedire con unico imballo

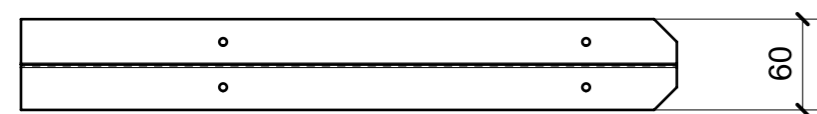
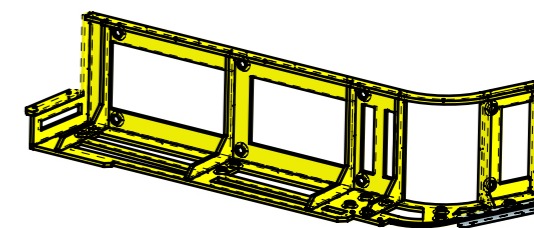

A10\_VH01\_01

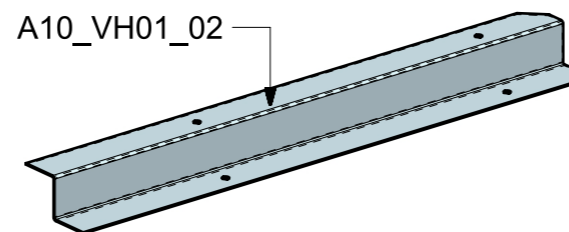
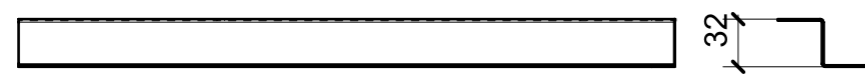

ELEMENTO DA MONTARE  
con VH01\_02 in MF\_VH02  
e spedire con unico imballo

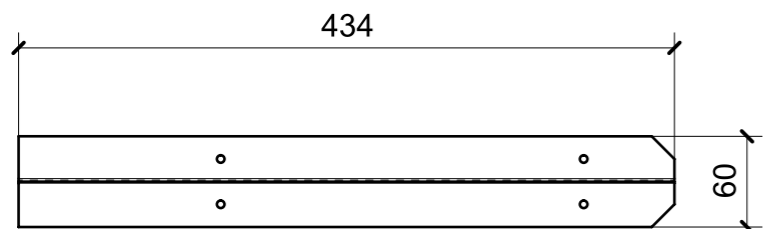
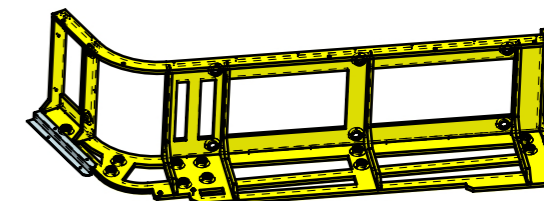

A10\_VH01\_02

LOCALE	CODICE	DESCRIZIONE COMPONENTE	FINITURA	Q.TA
CABINA VIP	MD298_A01_VM01	MURATA OBLO' SX	ACCIAIO GREZZO	1

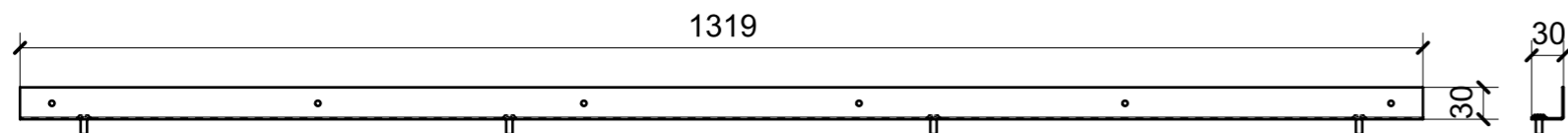

A12\_VM01\_01

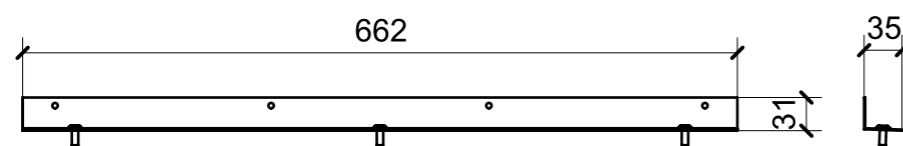

A11\_VM01\_01

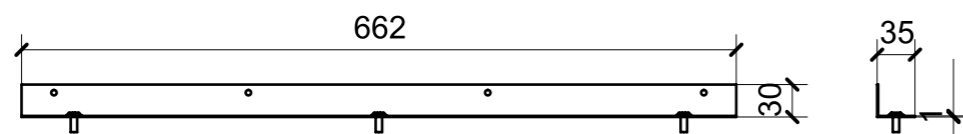

A11\_VM01\_02

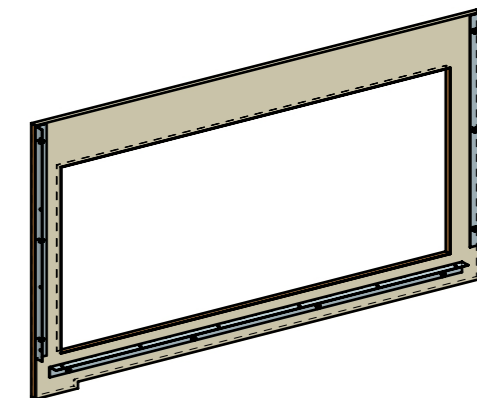

ELEMENTI DA MONTARE  
con R01 in MF\_VM01\_01  
e spedire con unico imballo

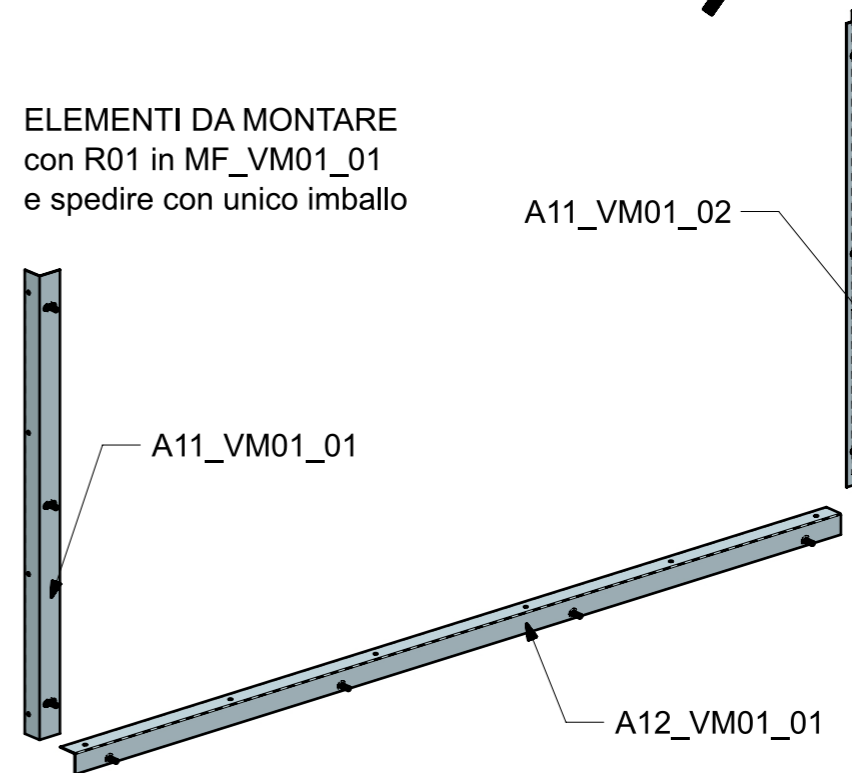

FERRAMENTA	QTY
VITE 6MA X 15 TESTA BOMBATA	10

LOCALE	CODICE	DESCRIZIONE COMPONENTE	FINITURA	Q.TA
CABINA VIP	MD298_A01_VN01	MURATA OBLO' DX	ACCIAIO GREZZO	1

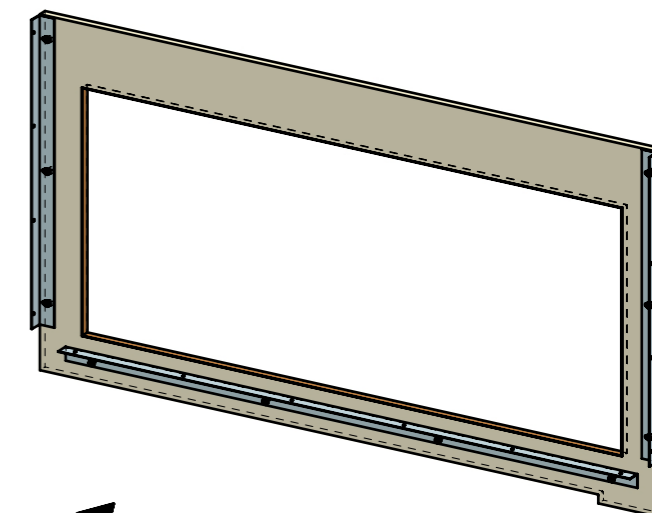
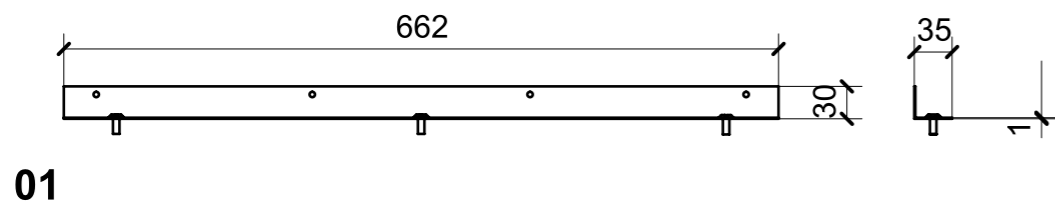
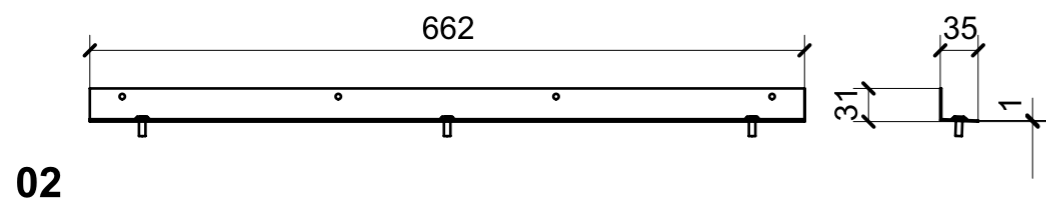
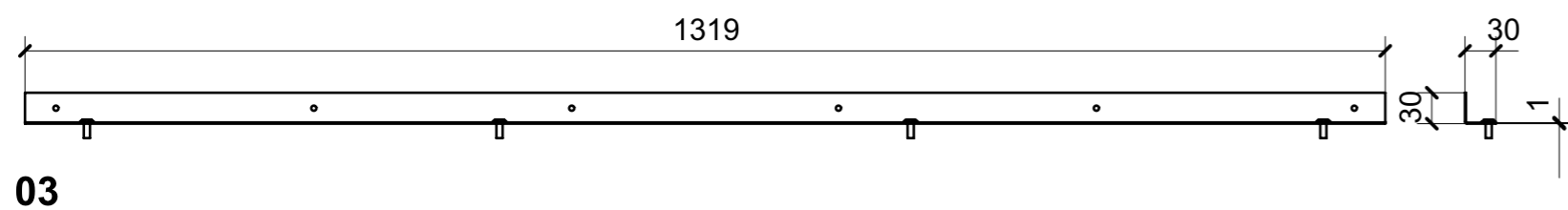

ELEMENTI DA MONTARE  
 con R01\_VN01\_01  
 in MF\_VN01  
 e spedire con unico imballo

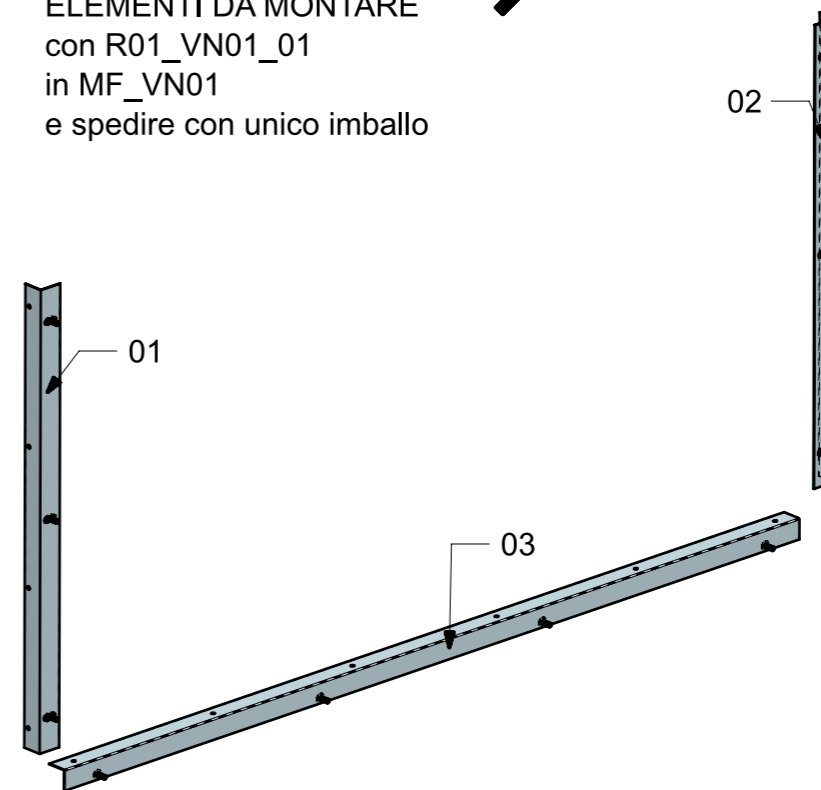

FERRAMENTA	QTY
VITE 6MA X 15 TESTA BOMBATA	10