

LOCALE	CODICE	DESCRIZIONE COMPONENTE	FINITURA	Q.TA
SALONE	MD298_A01_SP01	TAVOLO SALONE STD	ALLUMINIO VERNICIATO serie 90MFY-01.02	1

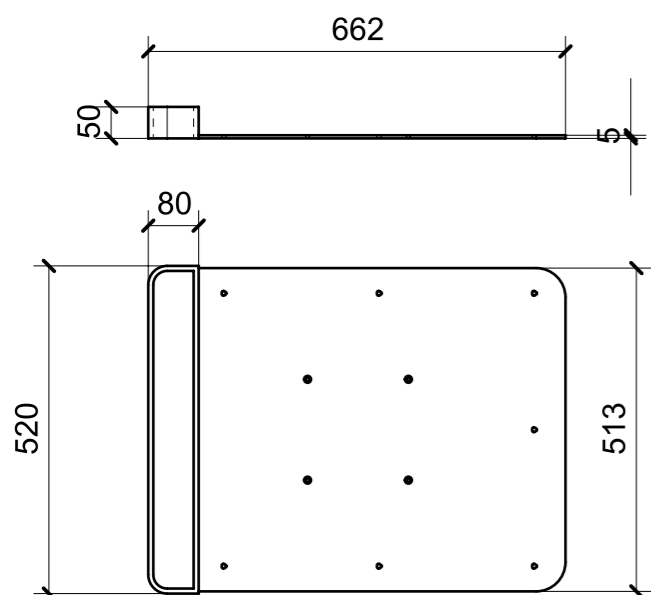

A36_SP01_01

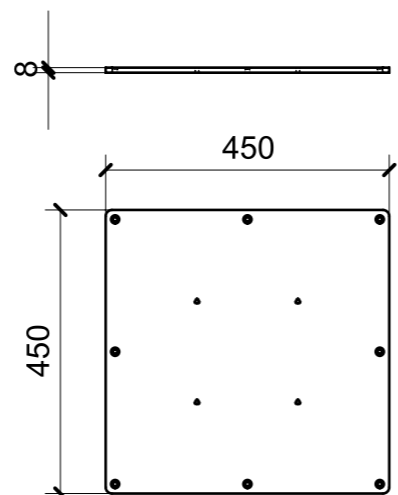

A38_SP01_01

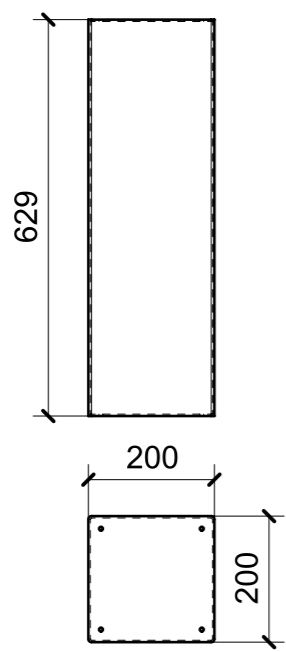

A37_SP01_01

ELEMENTI DA MONTARE
 con R01_SP01_01-->03; I01_SP01_01
 in MF_SP01
 e spedire con unico imballo

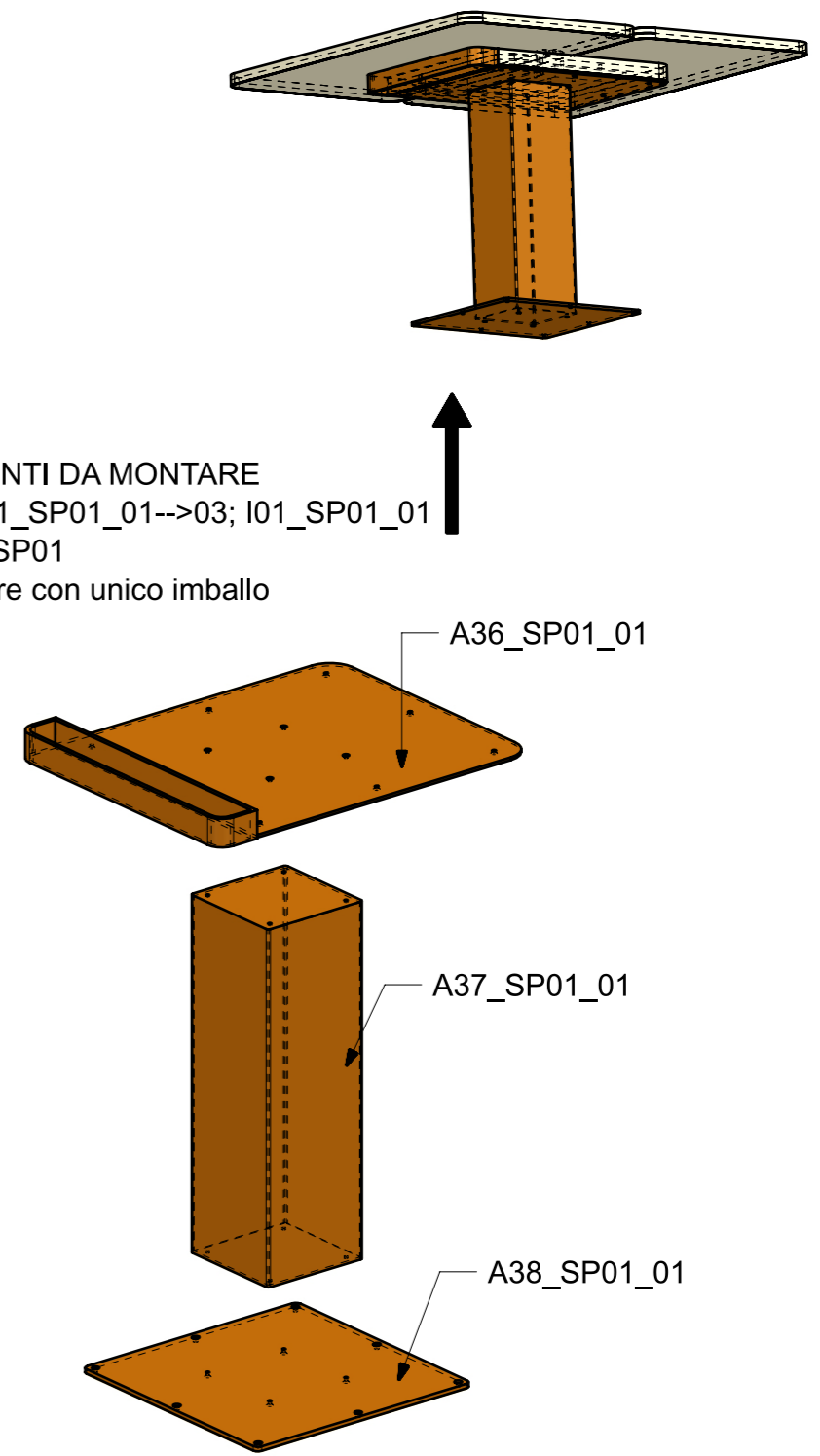

LOCALE	CODICE	DESCRIZIONE COMPONENTE	FINITURA	Q.TA
SALONE	MD298_A01_SQ01	TAVOLO SALONE OPT	ALLUMINIO SIMIL CAMPIONE PELLE M2553	1

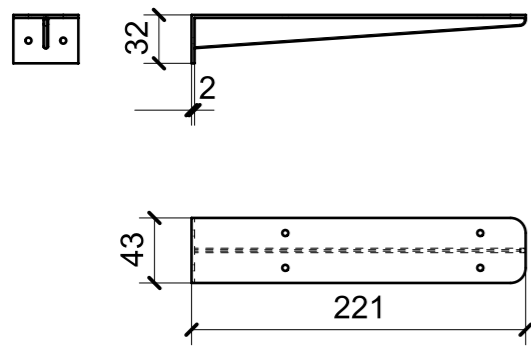

A39_SQ01_01

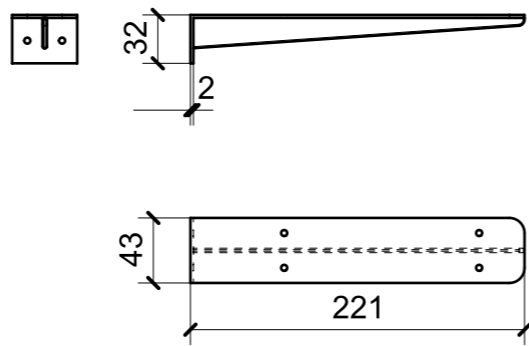

A39_SQ01_02

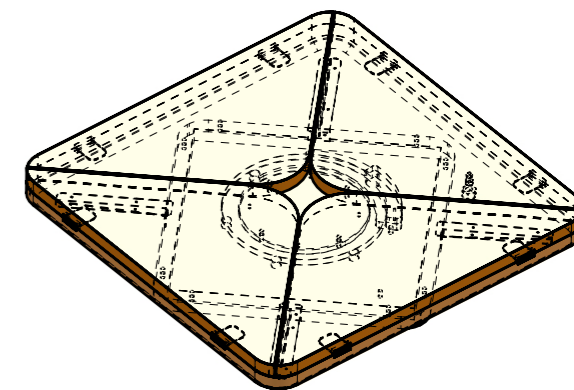

ELEMENTI DA MONTARE
 con SQ01_01/02; R01_SQ01/05
 L01_SQ01/02; X01_SQ01
 in MF_SQ01_01
 e spedire con unico imballo

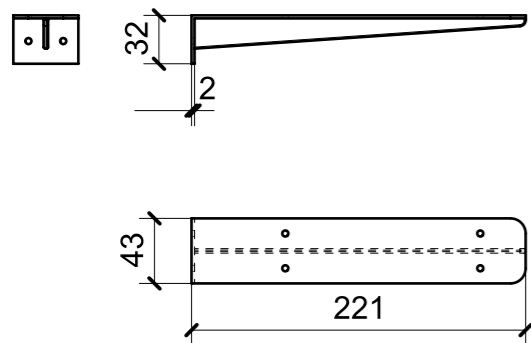

A39_SQ01_03

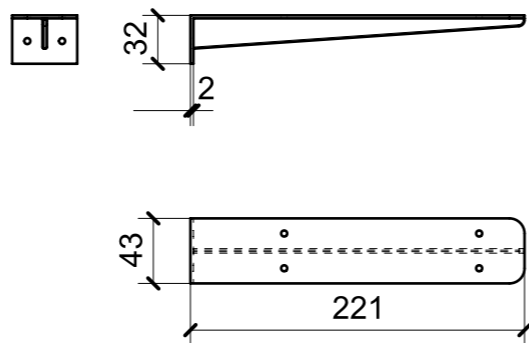

A39_SQ01_04

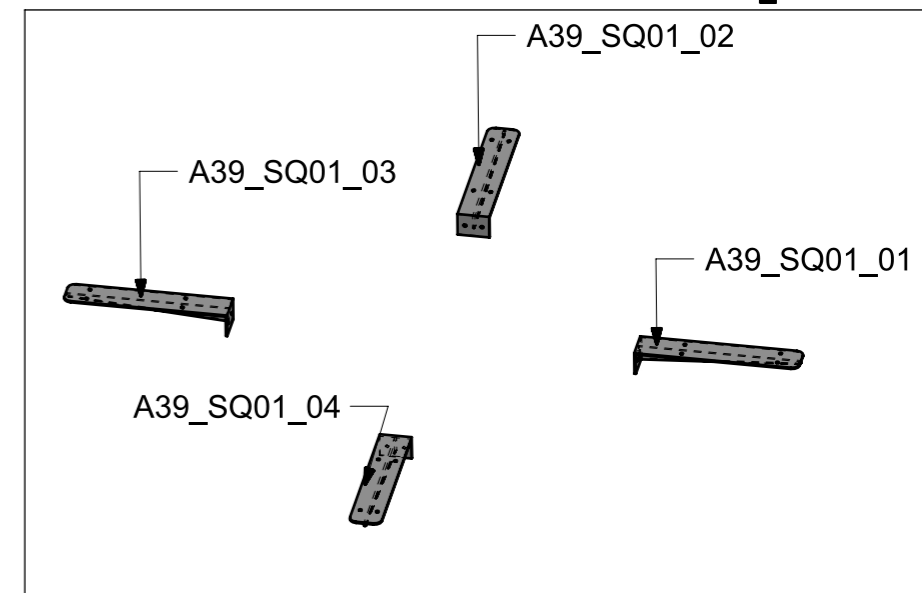

LOCALE	CODICE	DESCRIZIONE COMPONENTE	FINITURA	GR.
SALONE	MD320_A01_SR01	BRISE SOLEIL	ACCIAIO LACCATO RAL 1013	PTP

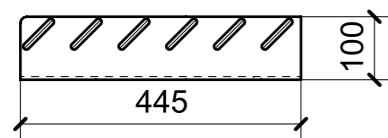

SECTION B-B

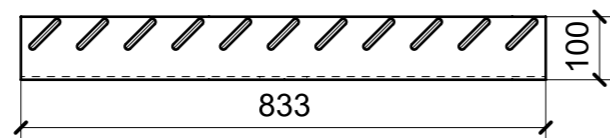

SECTION C-C

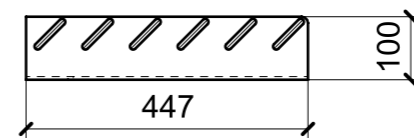

SECTION D-D

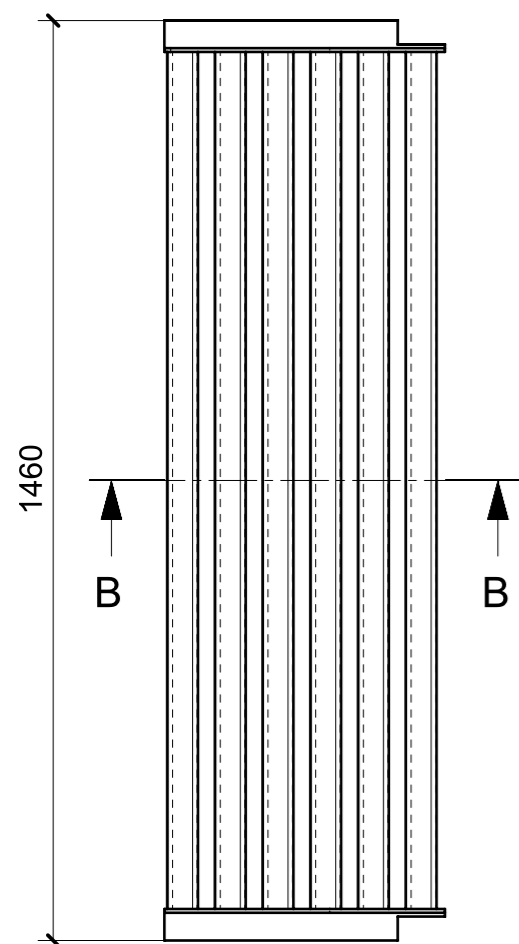

01

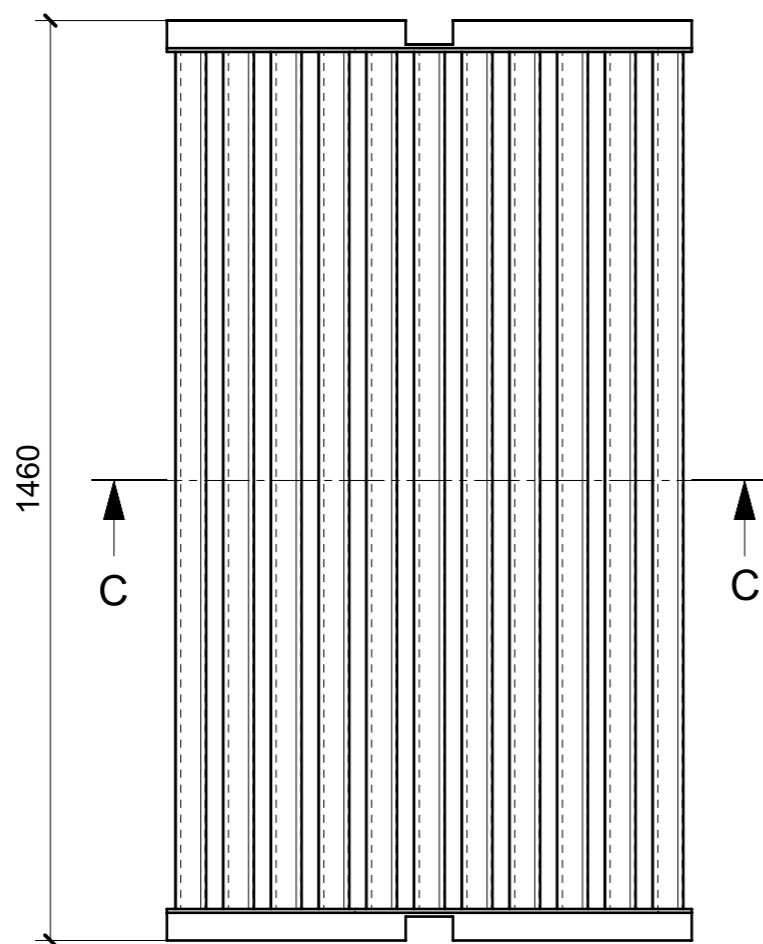

02

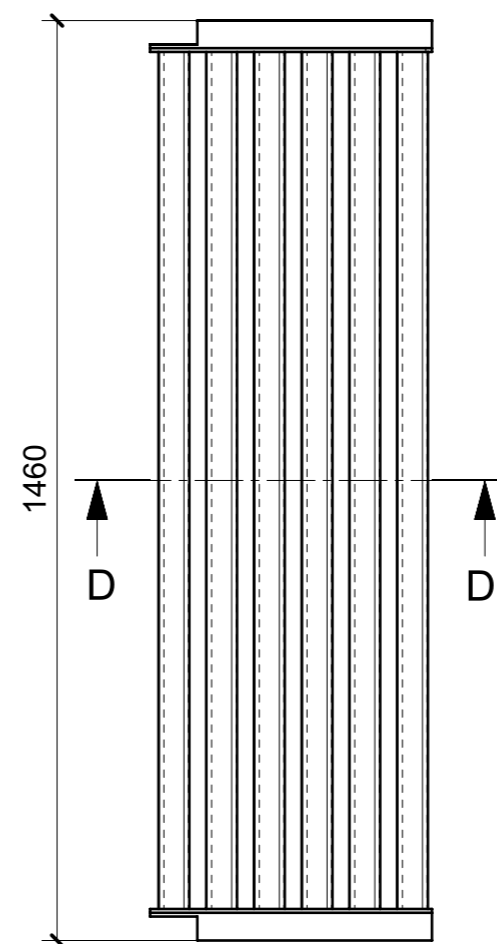

03

