

AZ68F

REV. 18-10-2022

LOCALE	CODICE	DESCRIZIONE COMPONENTE	FINITURA	Q.TA	OPERATORE
SALONE A POPPA	AZ68F-MF_SSD01	MURATA BASSA TV			Damiano

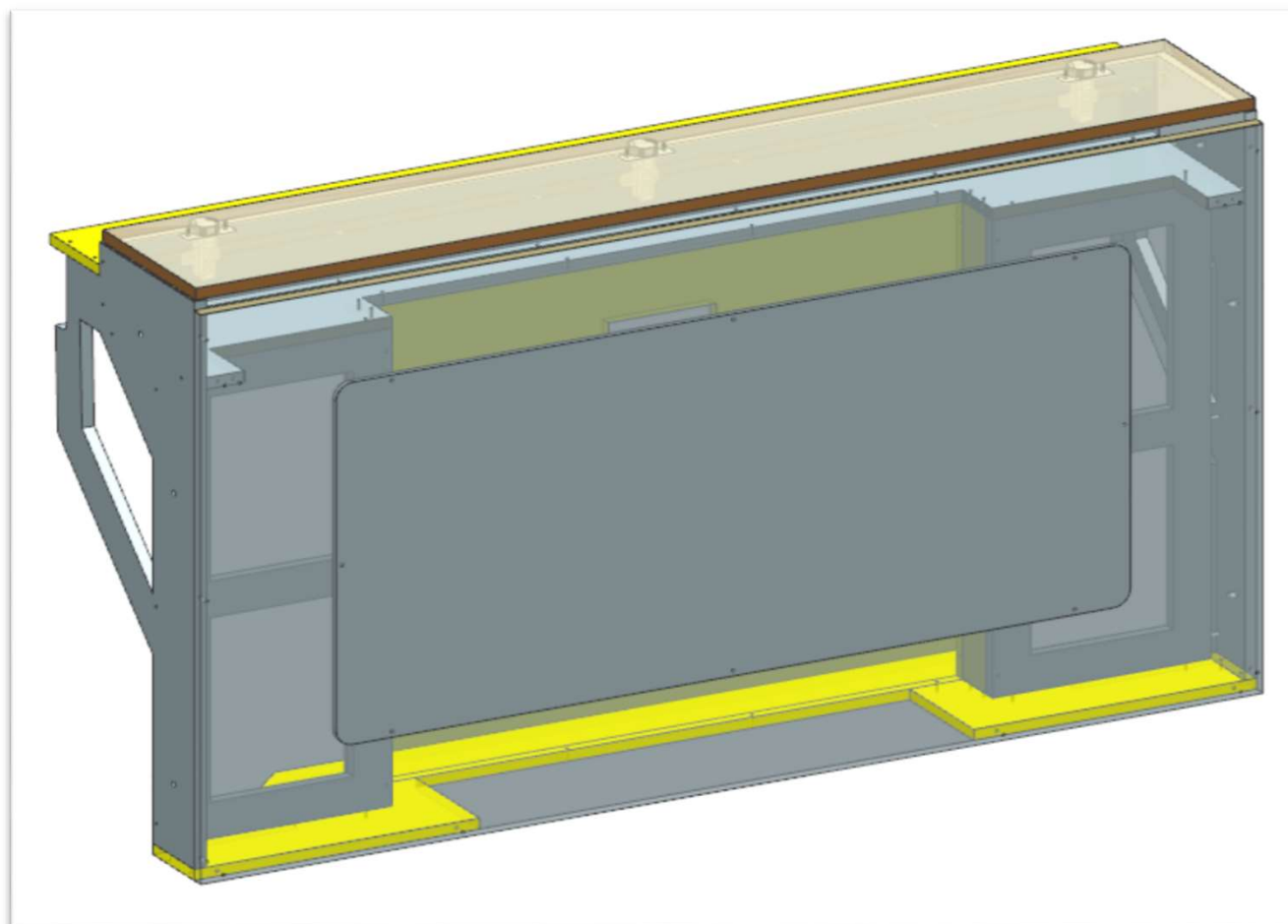

FERRAMENTA:

- N° 3 - CERNIERA PIANA
- N° 3 - Basetta H6
- N° 12 - ANKOR BORGHI
- N° 2 - GOMMINO PARACOLPI
- N° 6 - BUSSOLA ZAMA 6MA

AZ68F

REV. 29-04-2024

LOCALE	CODICE	DESCRIZIONE COMPONENTE	FINITURA	Q.TA	OPERATORE
SALONE A POPPA	AZ68F-SSD01	MURATA BASSA TV	LAMINATO NADIR	1	Damiano

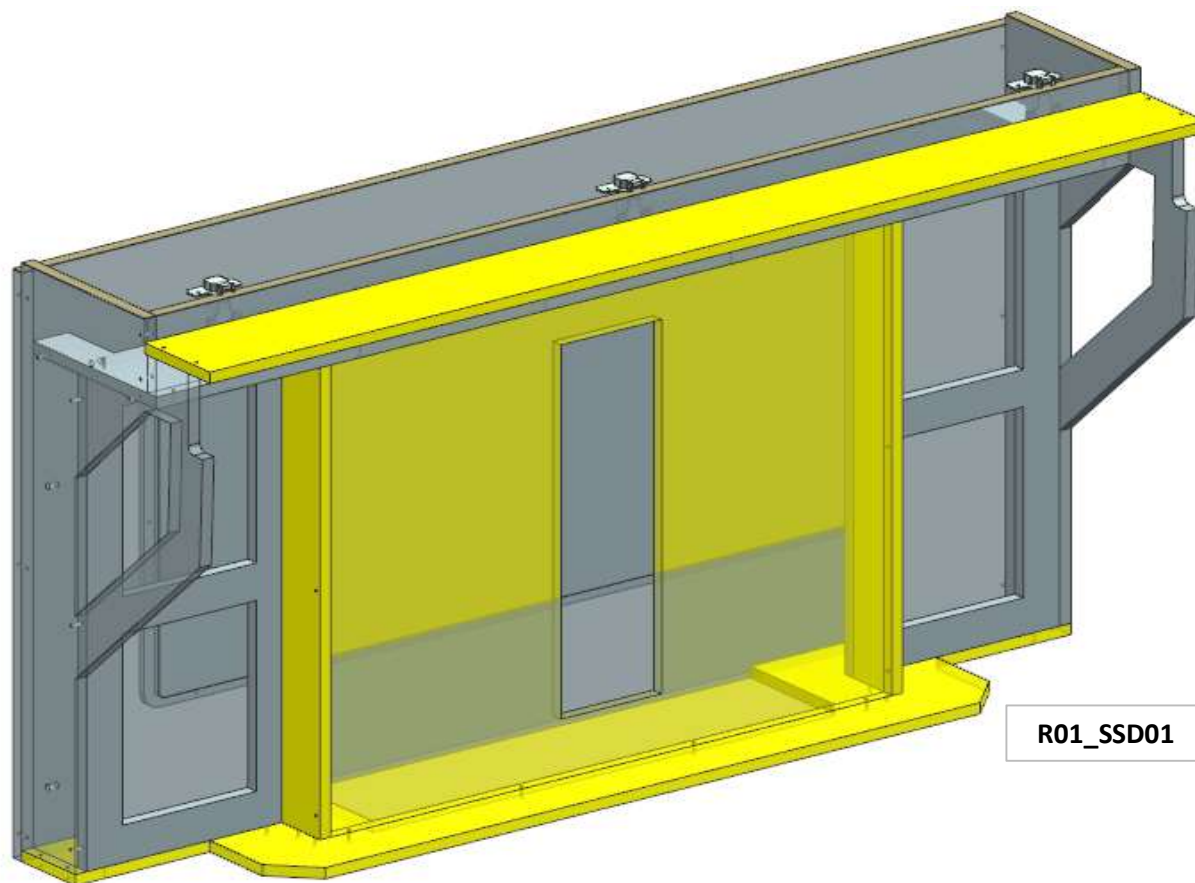

R01_SSD01

FERRAMENTA:

- N° 3 - CERNIERA PIANA SENZA MOLLA
- N° 3 - BASETTA H6
- N° 12 - ANKOR BORGHI
- N° 2 - GOMMINO PARACOLPI
- N° 6 - BUSSOLA ZAMA 6MA

ELEMENTO DA MONTARE:

R01-SSD01

e spedire con un unico imballo

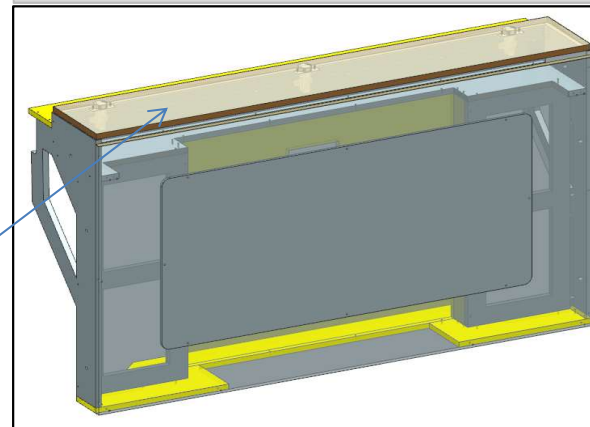

AZ68F

DA MAT.229

REV. 29-04-2024

LOCALE	CODICE	DESCRIZIONE COMPONENTE	FINITURA	Q.TA	OPERATORE
SALONE A POPPA	AZ68F-R01_SSD01	MURATA BASSA TV	LASTRA CHIARA	2	Damiano

- 1 - L 1380 x H 226 x sp 16mm
- 2 - L 2091 x H 49 x sp 16mm
- 3 - L 2091 x H 115 x sp 16mm

**VERIFICARE
PRESENZA
BORDO**

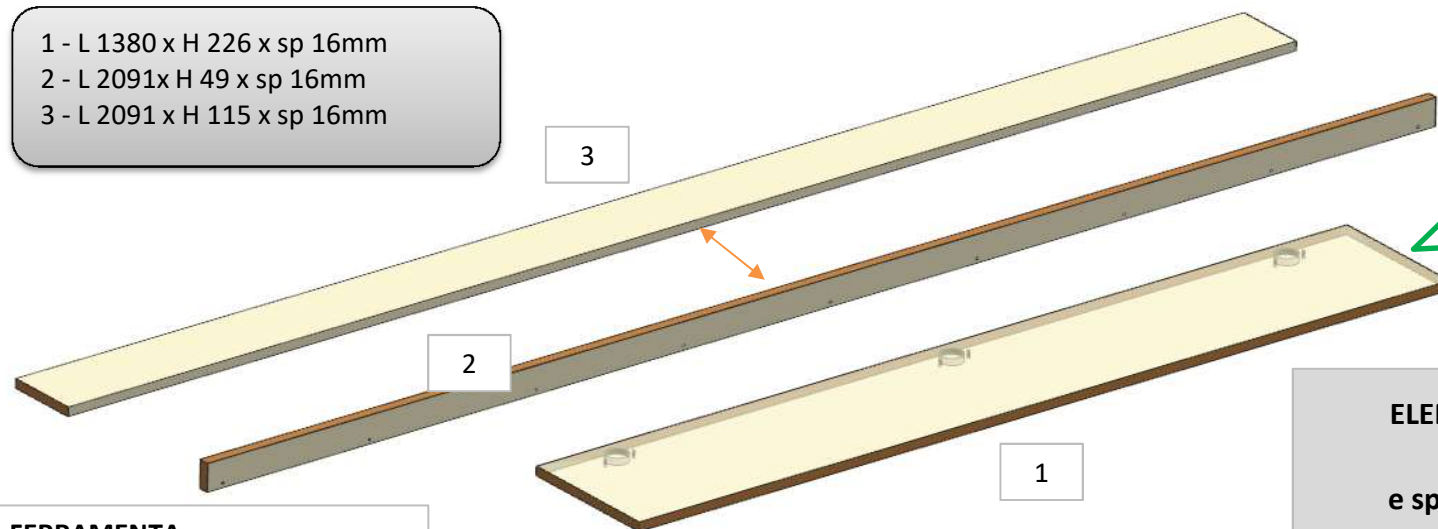

**ELEMENTO N.1 DA MONTARE:
SSD01
e spedire con un unico imballo**

FERRAMENTA:

- N° 3 - CERNIERA PIANA SENZA MOLLA
- N° 3 - Basetta H6
- N° 12 - ANKOR BORGHI
- N° 2 - GOMMINO PARACOLPI
- N° 6 - BUSSOLA ZAMA 6MA

**ELEMENTI N.2 E 3 DA MONTARE:
MG_SSD01
e spedire con un unico imballo**

MG_SSD01

SSD01

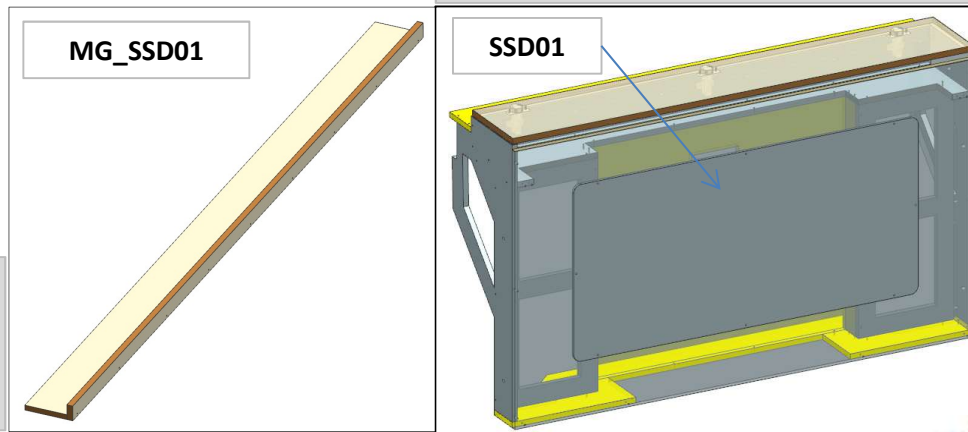

consonni&c

AZ68F

DA MAT.212 REV. 13-09-2021

LOCALE	CODICE	DESCRIZIONE COMPONENTE	FINITURA	Q.TA	OPERATORE
SALONE A POPPA	AZ68F-MG_SSD01	MURATA BASSA TV			Damiano

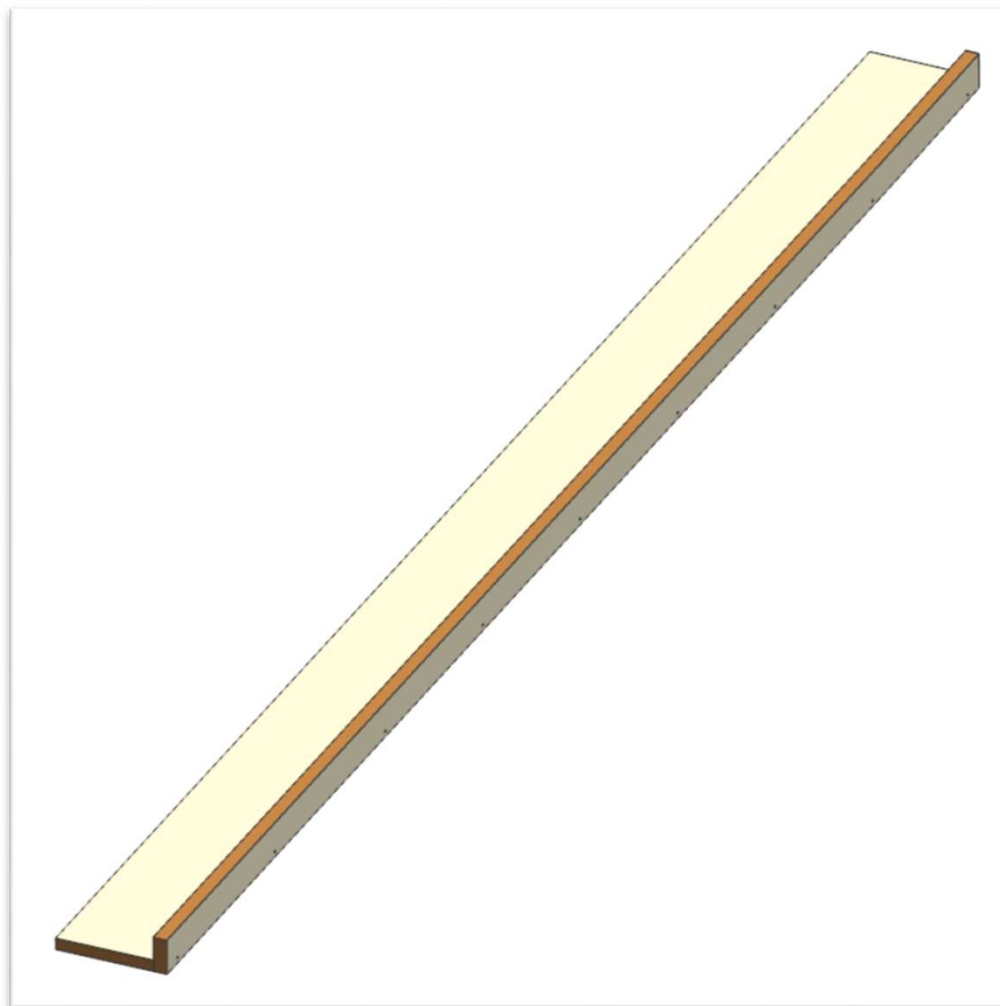

AZ68F

DA MAT. 203 REV. 18-10-2022

LOCALE	CODICE	DESCRIZIONE COMPONENTE	FINITURA	Q.TA	OPERATORE
SALONE A POPPA	AZ68F-MF_SSE01	CASSAPANCA DX			Damiano

MF-SSE02

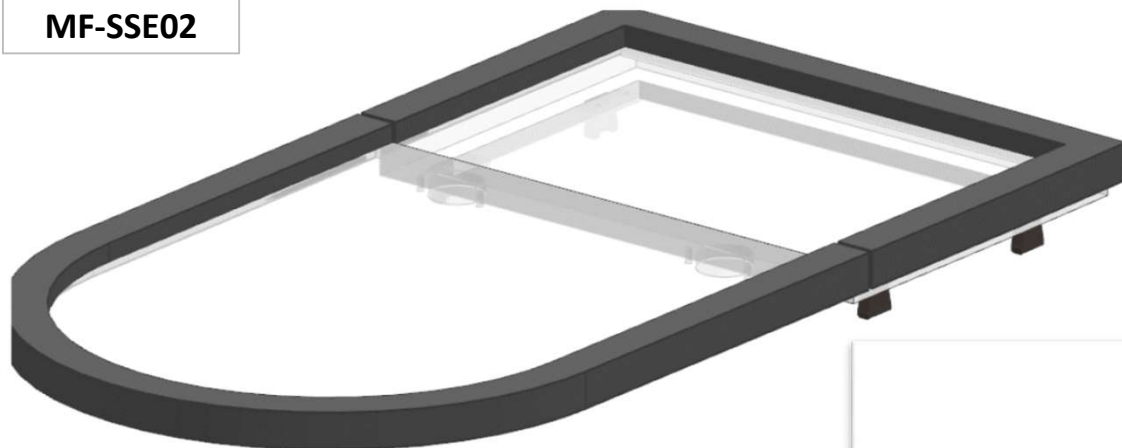

MF-SSE01

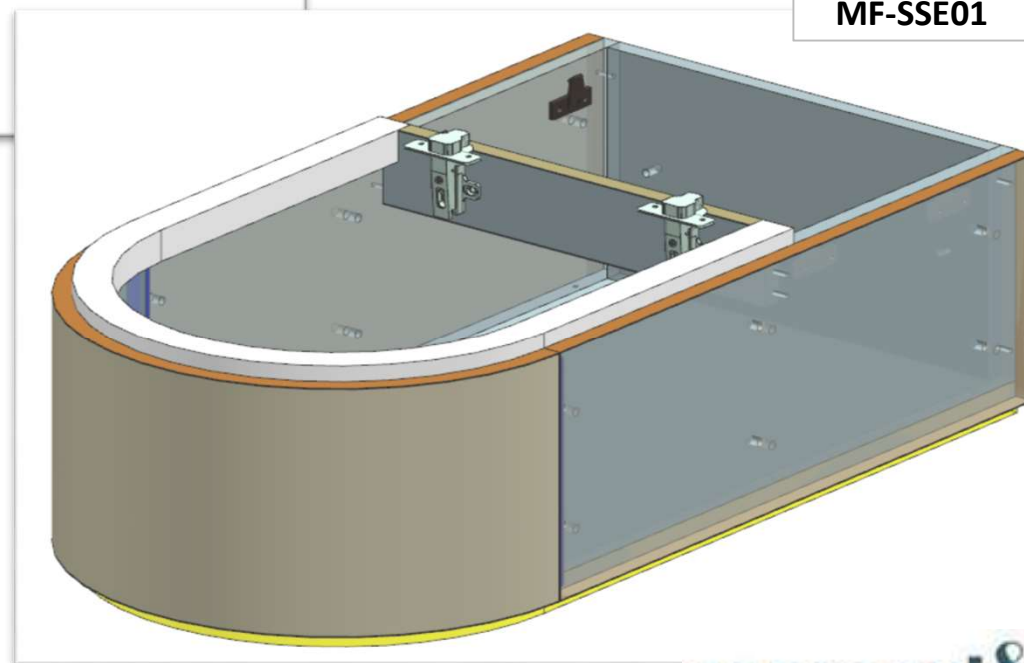

FERRAMENTA:

- N° 2 - CERNIERA MEZZO COLLO 40mm
- N° 2 - Basetta H0
- N° 8 - ANKOR BORGHI
- N° 2 - GOMMINO PARACOLPI
- N° 4 - KEKU FRONTALE
- N° 2 - VITI 6MA
- N° 12 - BUSSOLA ZAMA 6MA
- N° 1 - BRACCETTO A CIPOLLA

consonni&c

AZ68F

DA MAT. 203 REV. 29-04-2024

LOCALE	CODICE	DESCRIZIONE COMPONENTE	FINITURA	Q.TA	OPERATORE
SALONE A POPPA	AZ68F-SSE01	CASSAPANCA DX	LAMINATO NADIR	1	Damiano

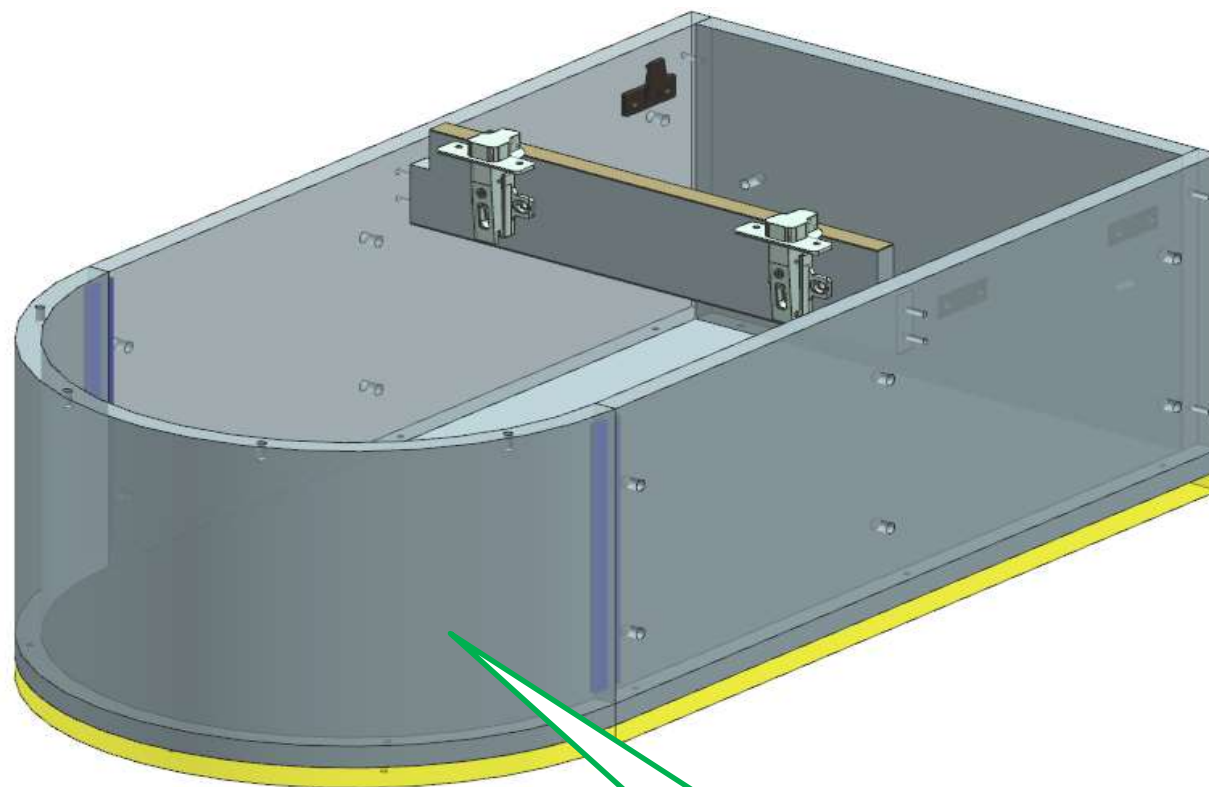

CURVA IN UN PEZZO SOLO

FERRAMENTA:

- N° 2 - CERNIERA MEZZO COLLO 40mm
- N° 2 - Basetta H0
- N° 8 - ANKOR BORGHI
- N° 2 - GOMMINO PARACOLPI
- N° 4 - KEKU FRONTALE
- N° 2 - VITI 6MA
- N° 12 - BUSSOLA ZAMA 6MA
- N° 1 - BRACCETTO A CIPOLLA

ELEMENTO DA MONTARE:

R01-SSE01

L01-SSE01

e spedire con un unico imballo

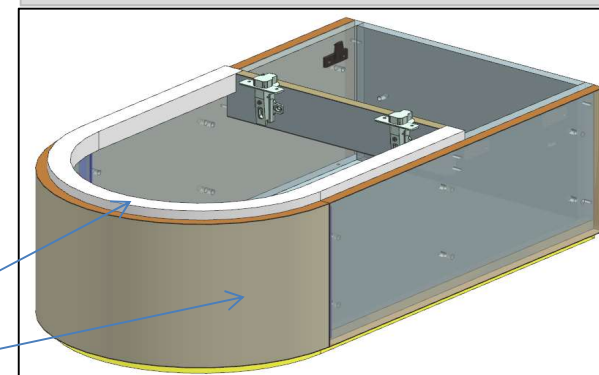

L01_SSE01
R01_SSE01

AZ68F

DA MAT. 203 REV. 29-04-2024

LOCALE	CODICE	DESCRIZIONE COMPONENTE	FINITURA	Q.TA	OPERATORE
SALONE A POPPA	AZ68F-R01_SSE01	CASSAPANCA DX	LASTRA CHIARA	3	Damiano

1 - 3 - L.598 x H 235 x sp 16
2 - SVILUPPO: L.706 x H 235 x sp 16

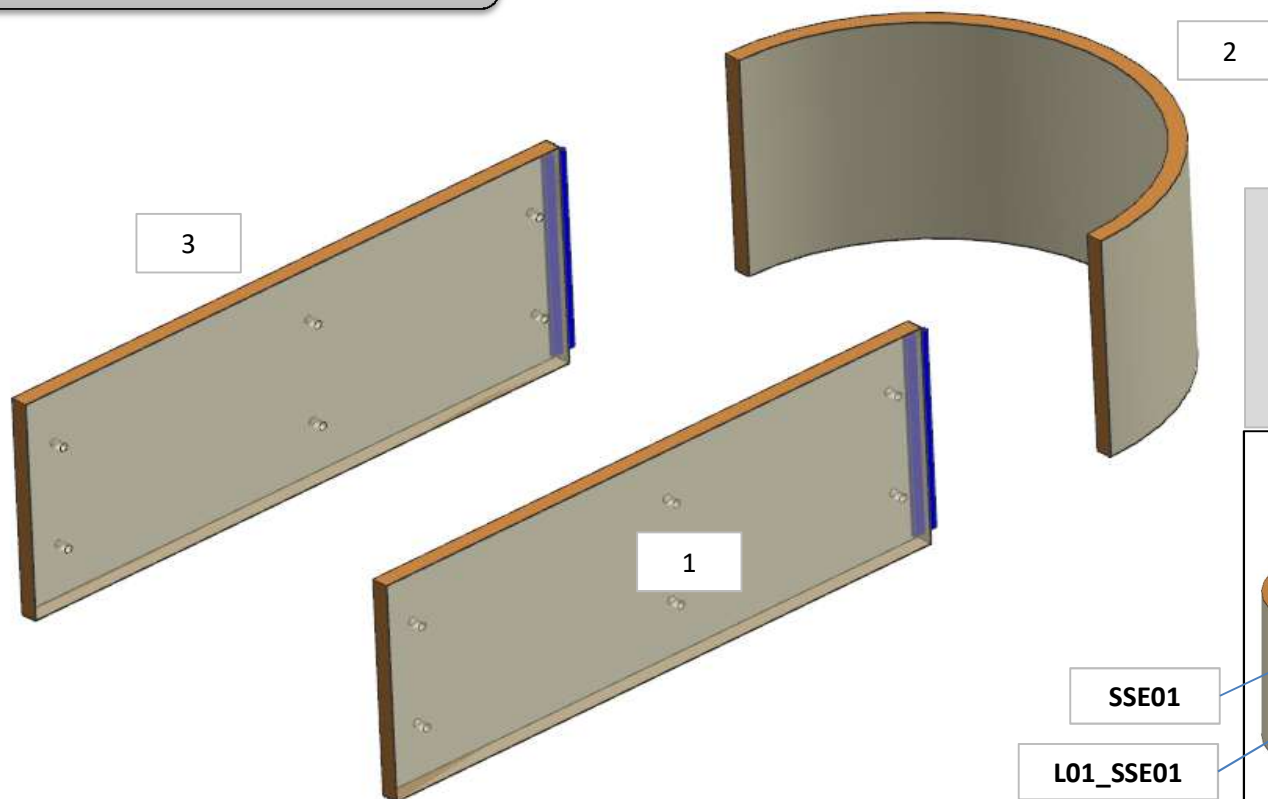

**ELEMENTO DA MONTARE:
SSE01
L01-SSE01
e spedire con un unico imballo**

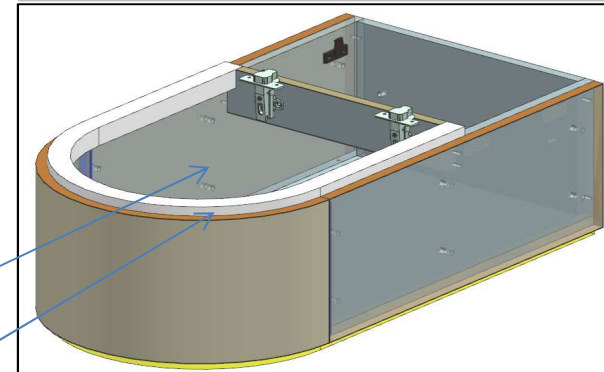

AZ68F

DA MAT. 203 REV. 18-10-2022

LOCALE	CODICE	DESCRIZIONE COMPONENTE	FINITURA	Q.TA	OPERATORE
SALONE A POPPA	AZ66F-L01_SSE01	CASSAPANCA DX	LACCATO BIANCO ARTICO	3	Damiano

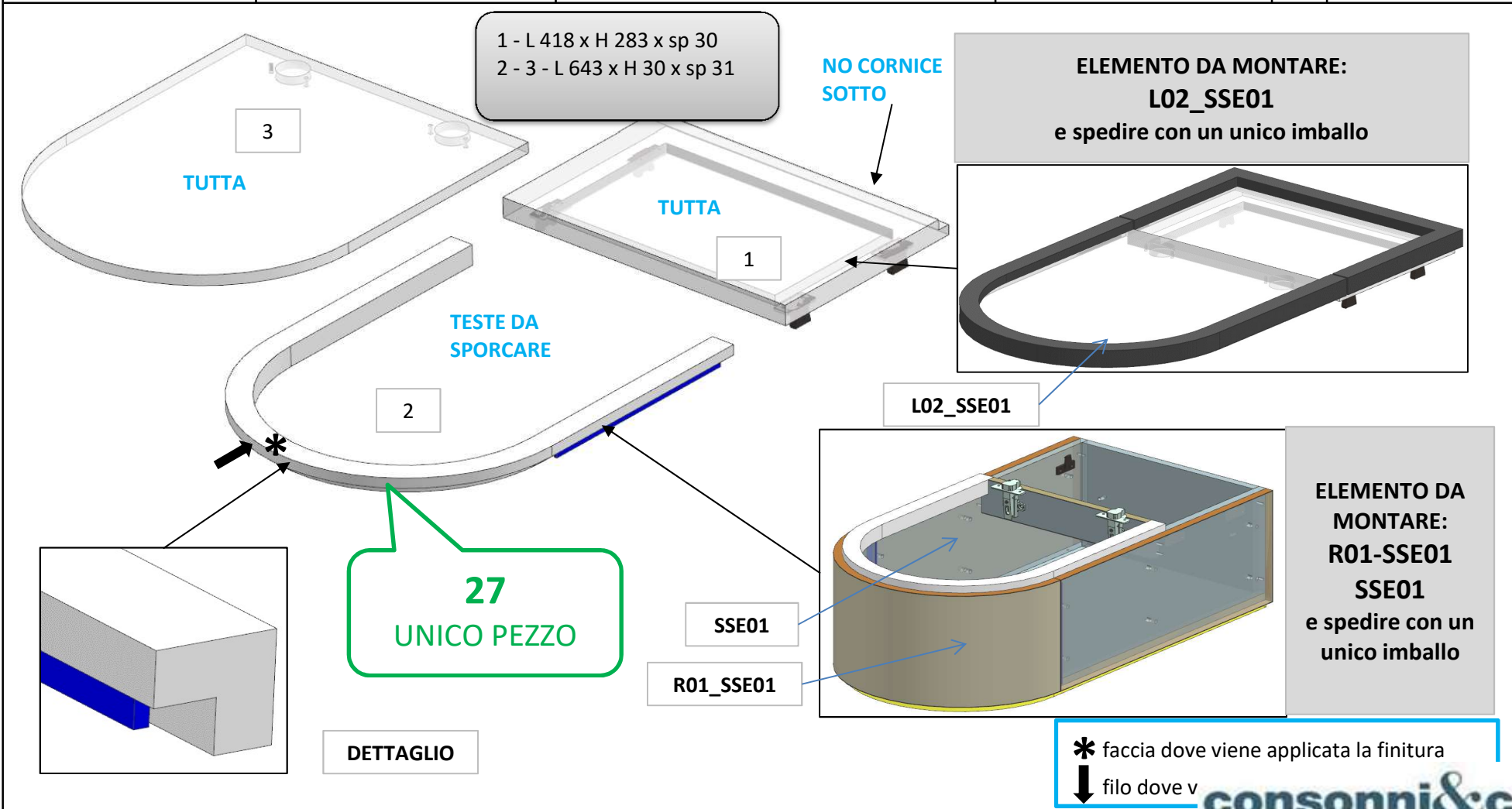

AZ68F

DA MAT. 203 REV. 18-10-2022

LOCALE	CODICE	DESCRIZIONE COMPONENTE	FINITURA	Q.TA	OPERATORE
SALONE A POPPA	AZ66F-L02_SSE01	CASSAPANCA DX	LACCATO MOGANO 100 GLOSS	2	Damiano

1 - L.450 x H 30 x sp 30
2 - SVILUPPO: L.1331 x H 283 x sp 30

DETTAGLIO

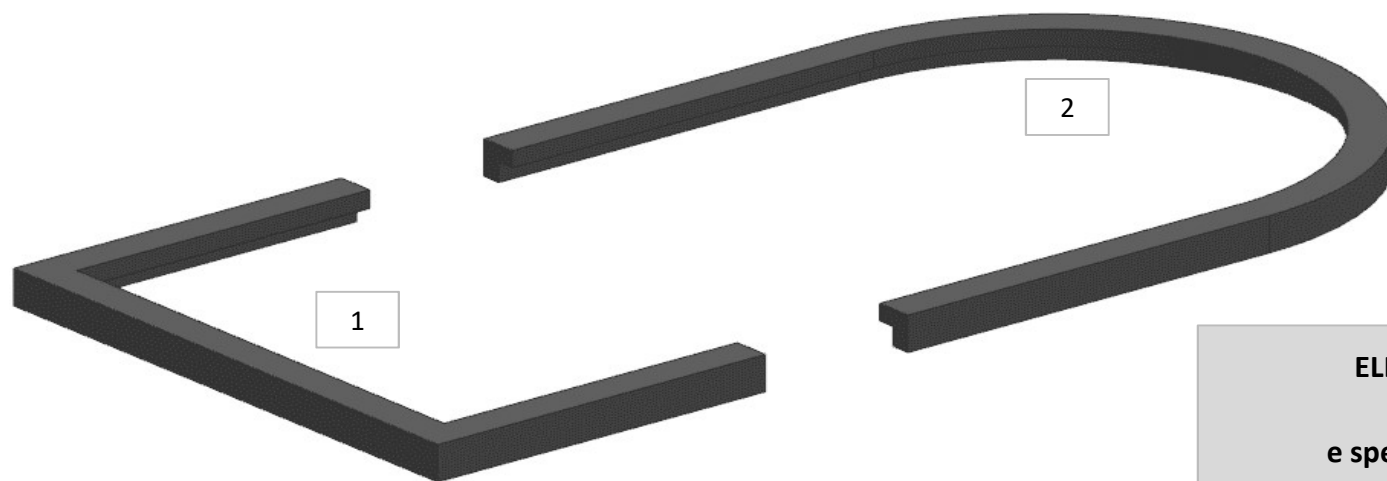
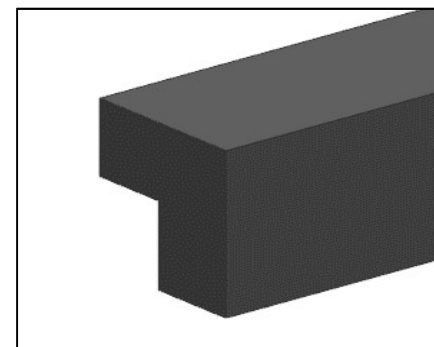

ELEMENTO DA MONTARE:
L01_SSE01
e spedire con un unico imballo

L01_SSE01

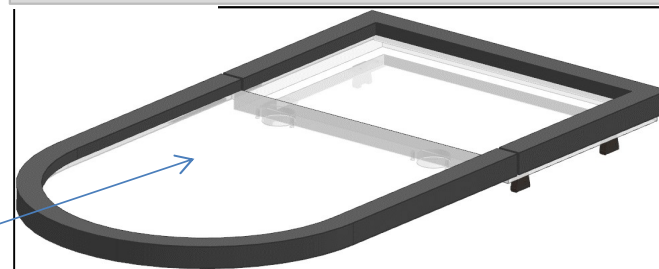

consonni&c