

AZ68F

DA MAT. 203 REV. 18-10-2022

LOCALE	CODICE	DESCRIZIONE COMPONENTE	FINITURA	Q.TA	OPERATORE
CUCINA A POPPA	AZ68F-MF_KKC01	STRUTTURA ZOCCOLO CUCINA			Damiano

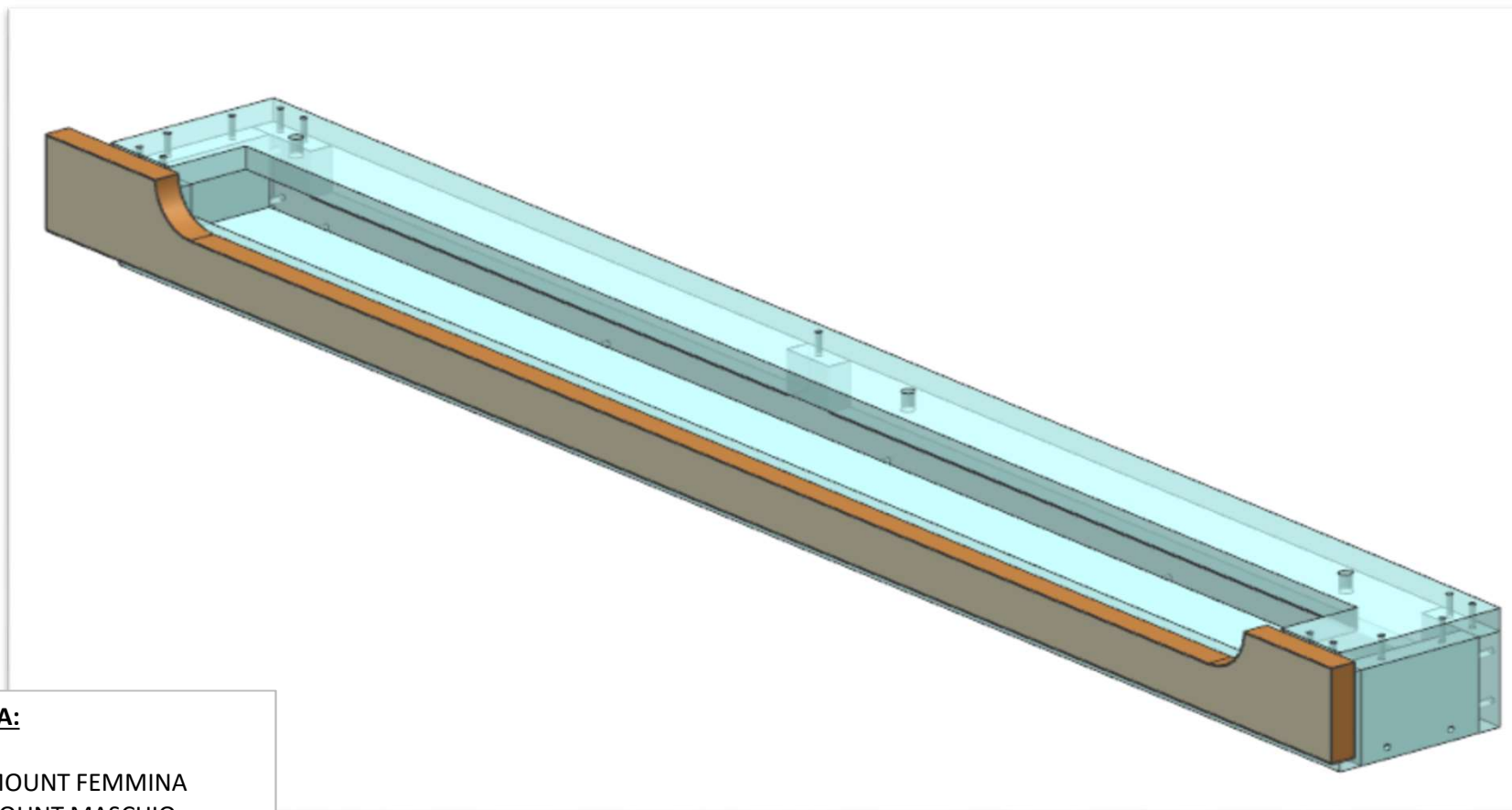

FERRAMENTA:

- N° 4 - FAST MOUNT FEMMINA
- N° 4- FAST MOUNT MASCHIO
- N° 3 - BUSSOLA ZAMA 6MA

AZ68F

DA MAT. 212 REV. 29-04-2024

LOCALE	CODICE	DESCRIZIONE COMPONENTE	FINITURA	Q.TA	OPERATORE
CUCINA A POPPA	AZ68F-KKC01	STRUTTURA ZOCCOLO CUCINA	VERNICIATO NERO	1	Damiano

1 - L 1050 x H.74 x sp 113

SPRUZZARE DI NERO

74mm

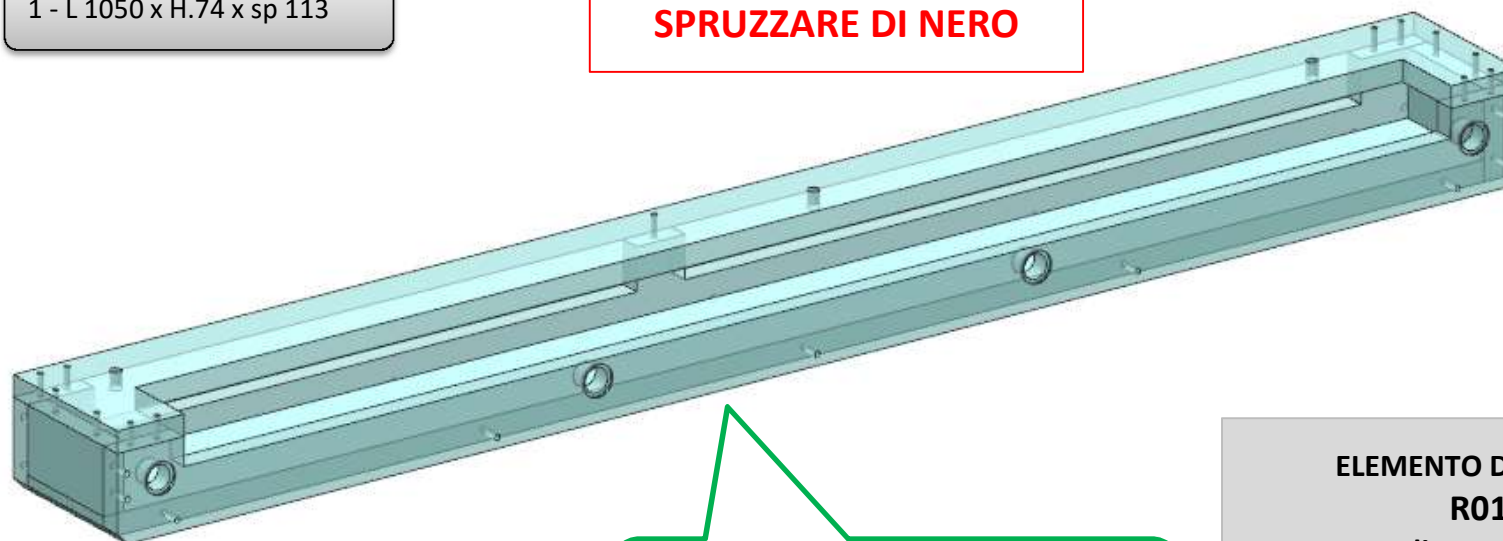

7 (step1)
RIDOTTA ALTEZZA DI 3mm

ELEMENTO DA MONTARE con:
R01_KKC01
e spedire con un unico imballo

FERRAMENTA:

N° 4 - FAST MOUNT FEMMINA
N° 4 - FAST MOUNT MASCHIO
N° 3 - BUSSOLA ZAMA 6MA

R01_KKC01

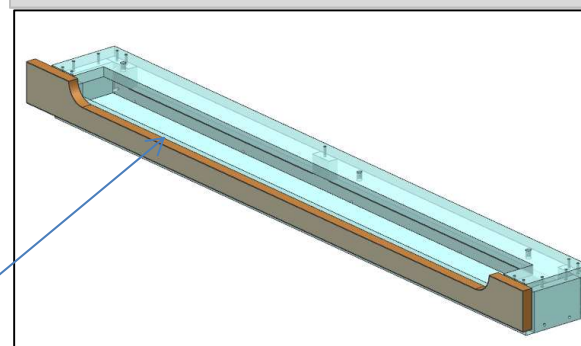

AZ68F

DA MAT. 203 REV. 29-04-2024

LOCALE	CODICE	DESCRIZIONE COMPONENTE	FINITURA	Q.TA	OPERATORE
CUCINA A POPPA	AZ68F-R01_KKC01	STRUTTURA ZOCCOLO CUCINA	LASTRA CHIARA	1	Damiano

1 - L.1099 x H62,5 x sp 16

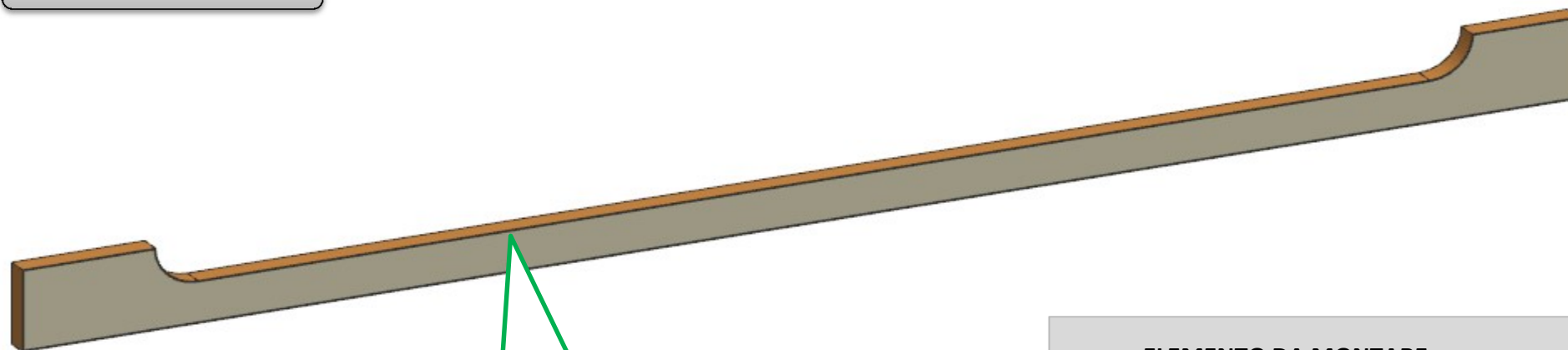

25
ZOCCOLO
DIVENTATO IN
LASTRA CHIARA

ELEMENTO DA MONTARE con:
KKC01
e spedire con un unico imballo

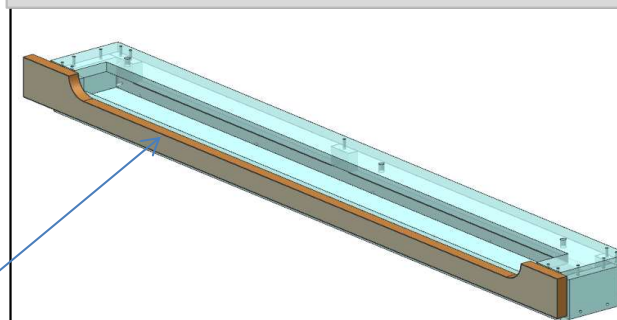

KKC01

consonni&c

AZ68F

DA MAT. 265 REV. 29-04-2024

LOCALE	CODICE	DESCRIZIONE COMPONENTE	FINITURA	Q.TA	OPERATORE
CUCINA A POPPA	AZ68F-KKF01	STRUTTURA MURATA PLENUM	OKOUME' GREZZO \ LAMINATO NADIR \ ANTIROMBO	4	Damiano

MOD. INT.
PLENUM DIVISO DA STRUTTURA.
VERNICIARE CON ANTI-ROMBO

FERRAMENTA:

- N° 17 - FITLOCK MASCHIO
- N° 17 - FITLOCK FEMMINA
- N° 8 - KEKU FRONTALE
- N° 1 - ALZA PAIOLO
- N° 9 - BUSSOLA ZAMA 6MA
- N° 6 - VITI 6MA

MODIFICATO
STRUTTURA

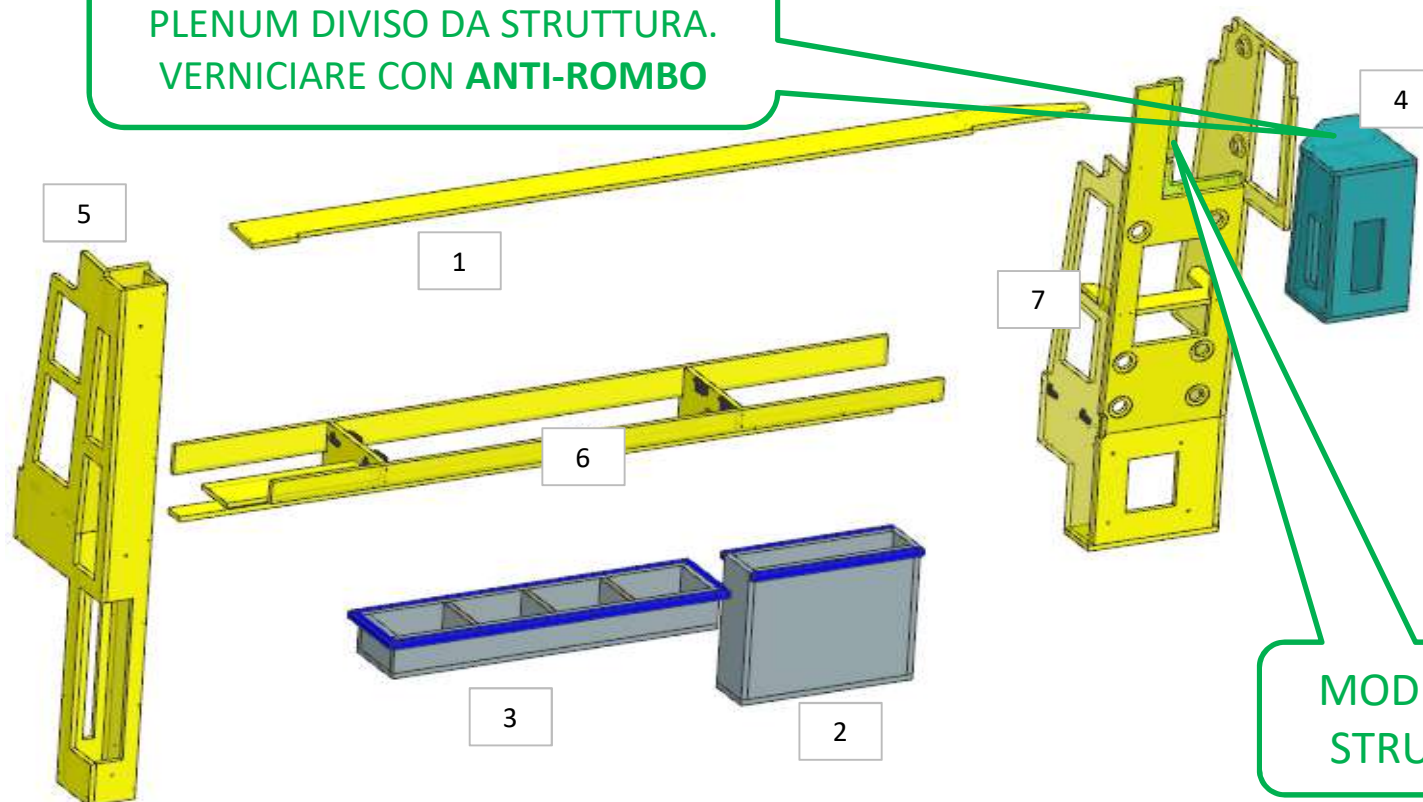

AZ68F

DA MAT. 265 REV. 29-04-2024

LOCALE	CODICE	DESCRIZIONE COMPONENTE	FINITURA	Q.TA	OPERATORE
CUCINA A POPPA	AZ68F-R01_KKF01	STRUTTURA MURATA PLENUM	LASTRA CHIARA	13	Damiano

1 - L 143 x H 566 x sp 16mm
 2 - L 1919 x H 326 x sp 16mm
 3 - L 944 x H 244 x sp 16mm
 4 - L 390 x H 485 x sp 32mm
 5 - L 390 x H 163 x sp 32mm
 6 - L 425 x H 405 x sp 32mm

8 - dia 32 x H 872mm
 9 - dia 32 x H 405mm
 10 - dia 32 x H 485mm
 11 - dia 32 x H 80mm
 12 - dia 32 x H 565mm
 13 - L 944 x H 244 x sp 16

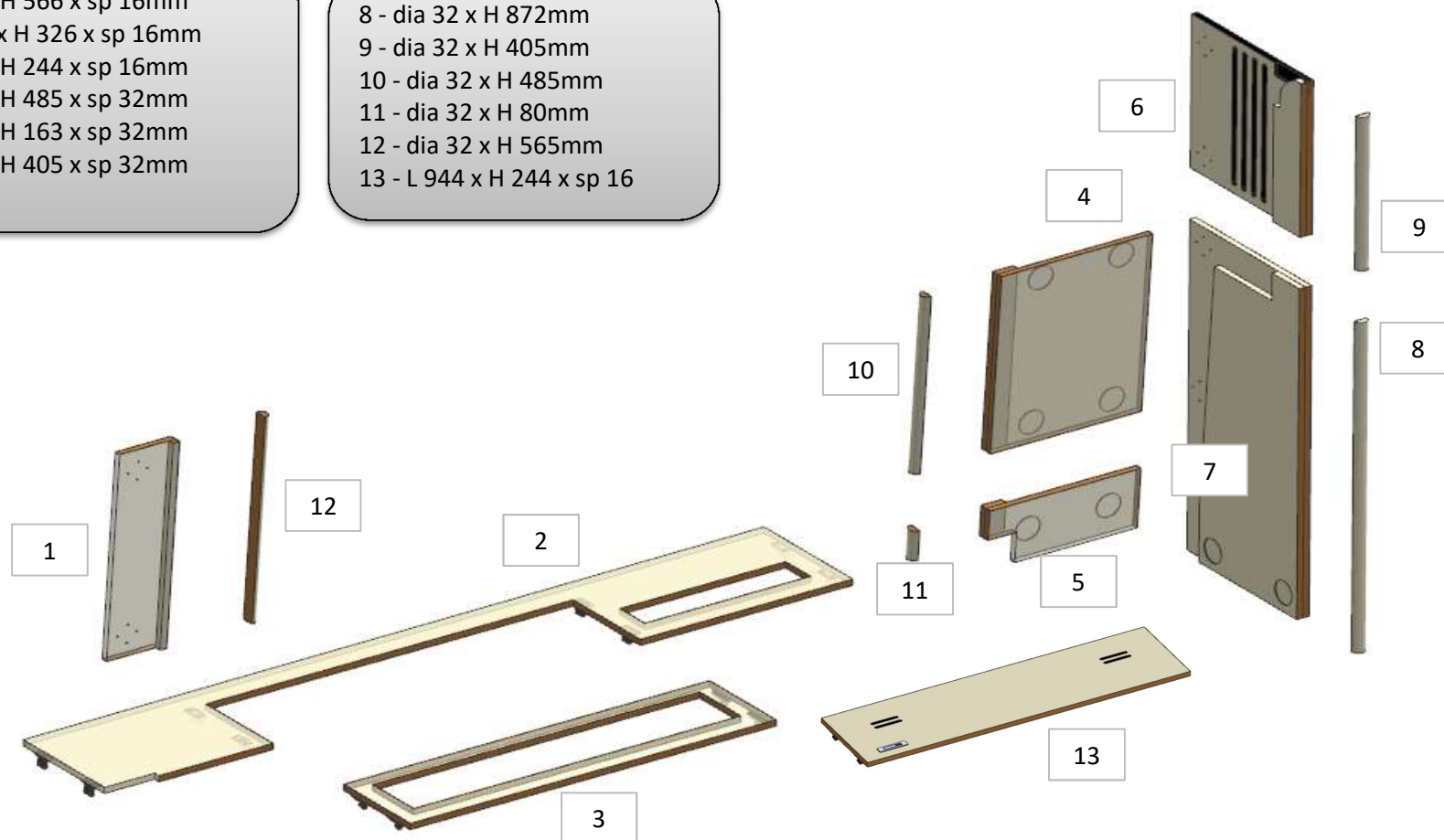

AZ68F

DA MAT. 265 REV. 29-04-2024

LOCALE	CODICE	DESCRIZIONE COMPONENTE	FINITURA	Q.TA	OPERATORE
CUCINA A POPPA	AZ68F-R02_KKF01	STRUTTURA MURATA PLENUM	LASTRA TEAK	2	Damiano

- 1 - L 441 x H 33 x sp 6
- 2 - L 441 x H.33 x sp 6

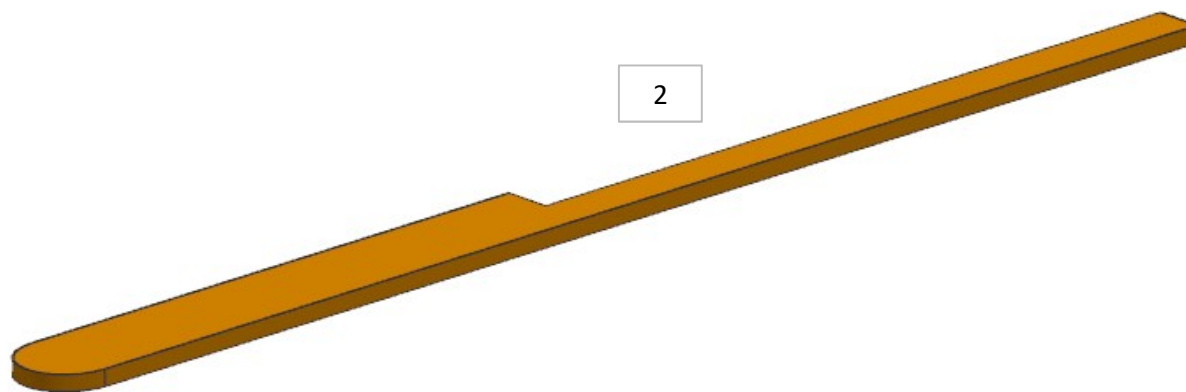
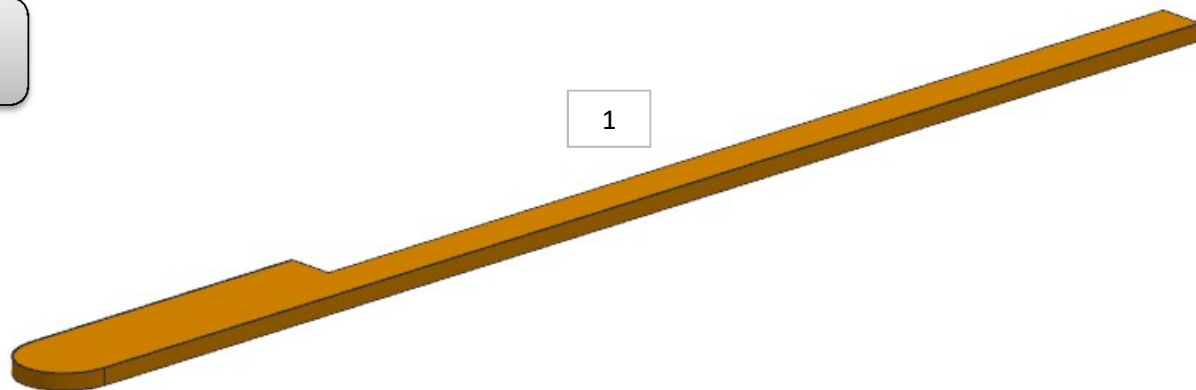

AZ68F

DA MAT. 203 REV. 14-10-2022

LOCALE	CODICE	DESCRIZIONE COMPONENTE	FINITURA	Q.TA	OPERATORE
CUCINA A POPPA	AZ68F-L01_KKF01	STRUTTURA MURATA PLENUM	LACCATO NERO	3	Damiano

- 1 - L 278 x H.696 x sp 16
- 2 - L 290 x H.696 x sp 15
- 3 - L 226 x H.1022 x sp 10

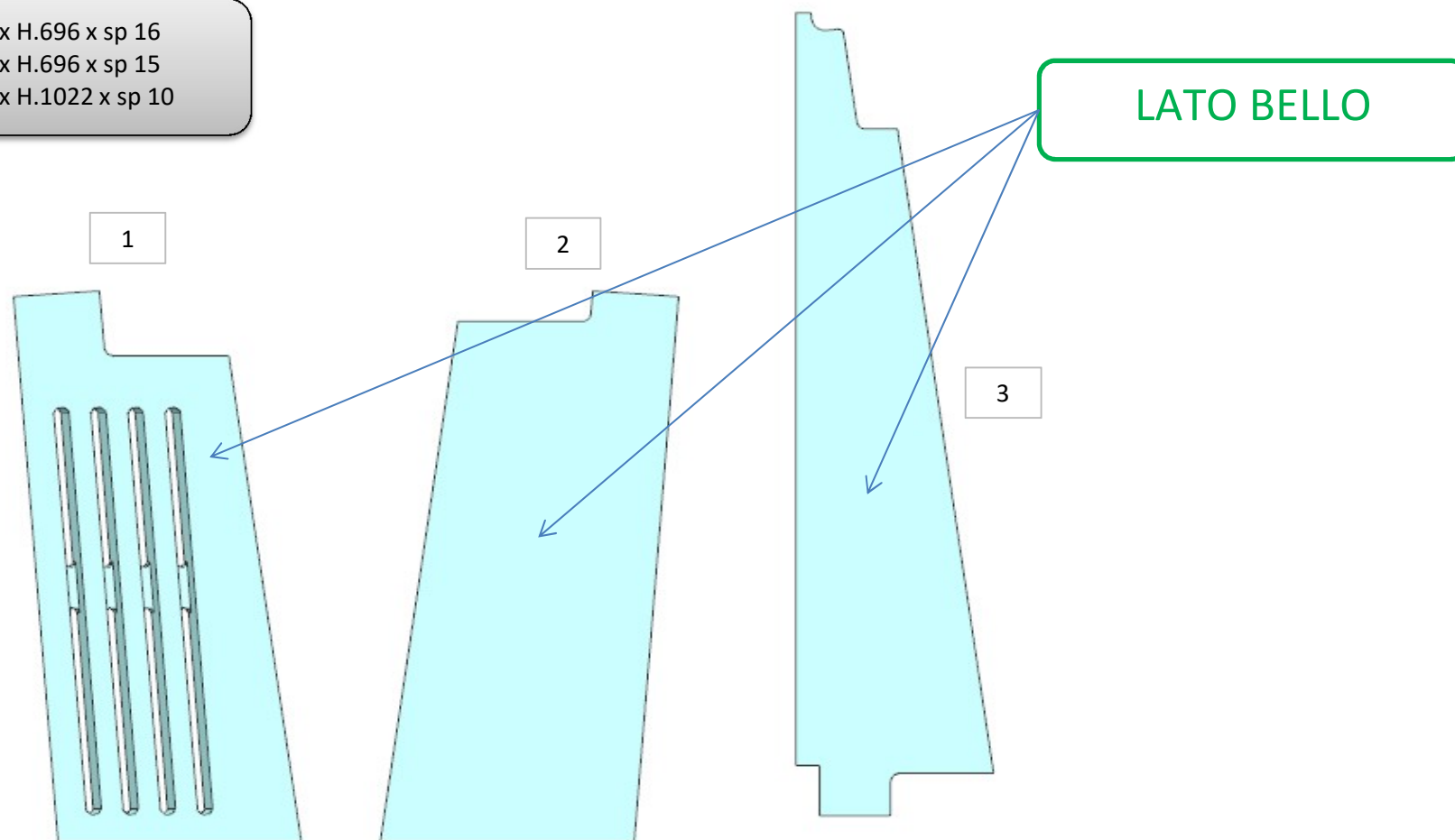

AZ68F

DA MAT. 203 REV. 13-09-2021

LOCALE	CODICE	DESCRIZIONE COMPONENTE	FINITURA	Q.TA	OPERATORE
CUCINA A POPPA	AZ68F-A01_KKF01	STRUTTURA MURATA PLENUM	RIMEX NERO	2	Damiano

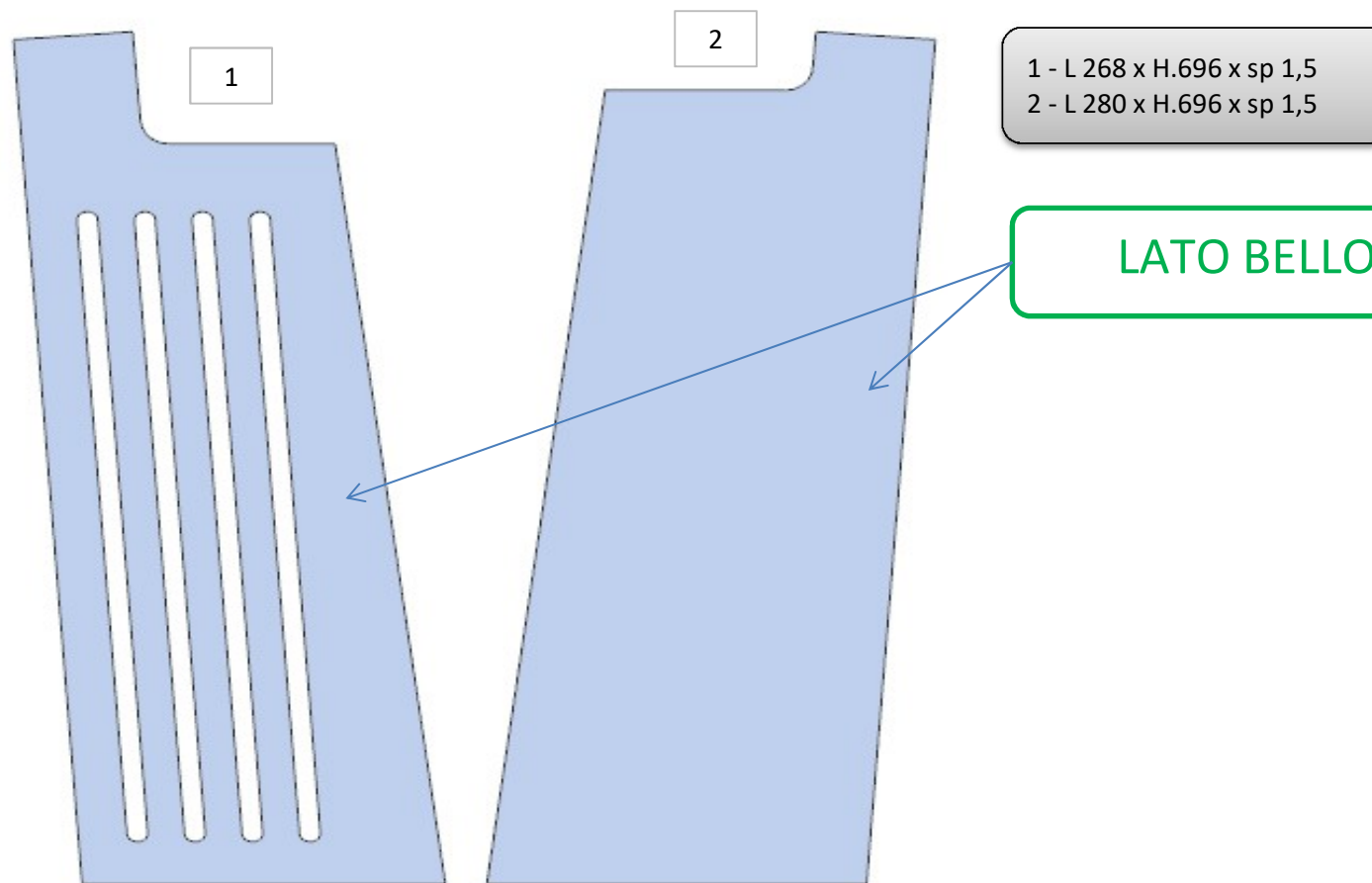

AZ68F

DA MAT. 203 REV. 13-09-2021

LOCALE	CODICE	DESCRIZIONE COMPONENTE	FINITURA	Q.TA	OPERATORE
CUCINA A POPPA	AZ68F-I01_KKF01	STRUTTURA MURATA PLENUM	OKOUME' GREZZO	2	Dante

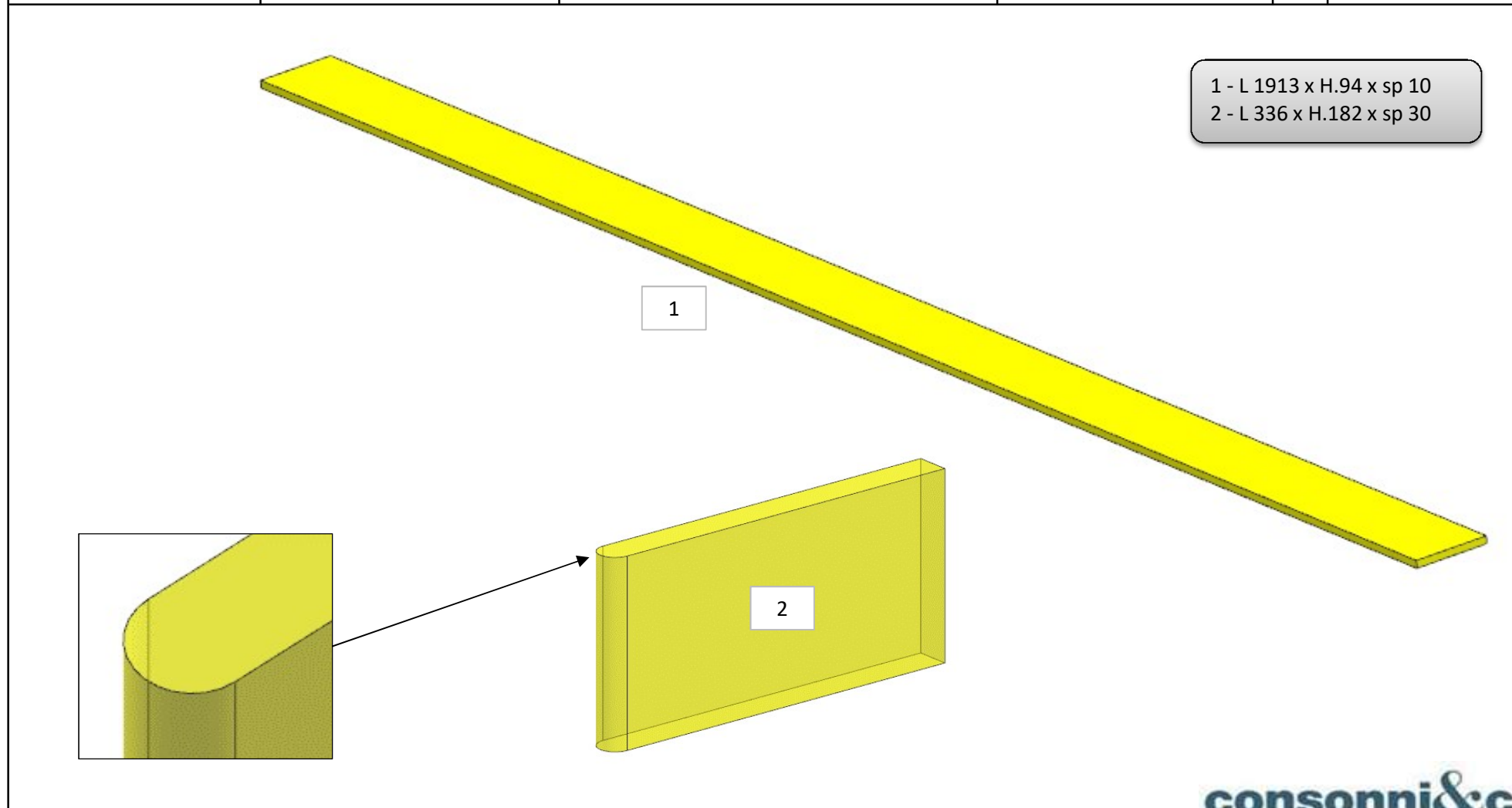

AZ68F

DA MAT. 212

REV. 29-04-2024

LOCALE	CODICE	DESCRIZIONE COMPONENTE	FINITURA	Q.TA	OPERATORE
CUCINA A POPPA	AZ68F-R01_KKL01	RIV. GRADINO COPERTA	LASTRA CHIARA	1	Damiano

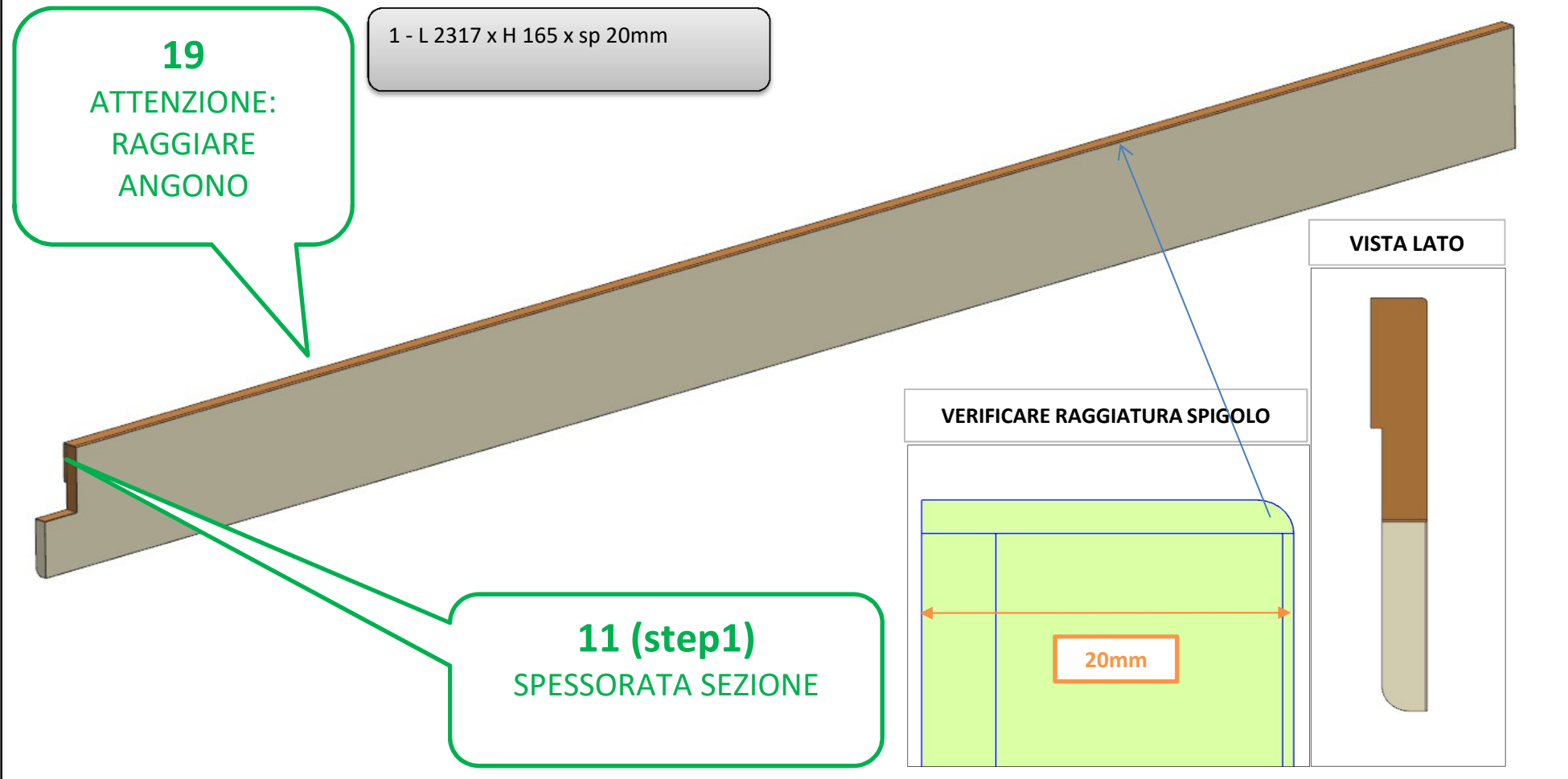

AZ68F

REV. 29-04-2024

LOCALE	CODICE	DESCRIZIONE COMPONENTE	FINITURA	Q.TA	OPERATORE
CUCINA A POPPA	AZ68F-KKM01	CORNICE CHIUSURA FRIGO	MDF GREZZO	3	Dante

1 - L 992 x H 95 x 63 mm
2 - L 958 x H 96 x 373 mm
3 - L 400 x H 95 x sp 16 mm

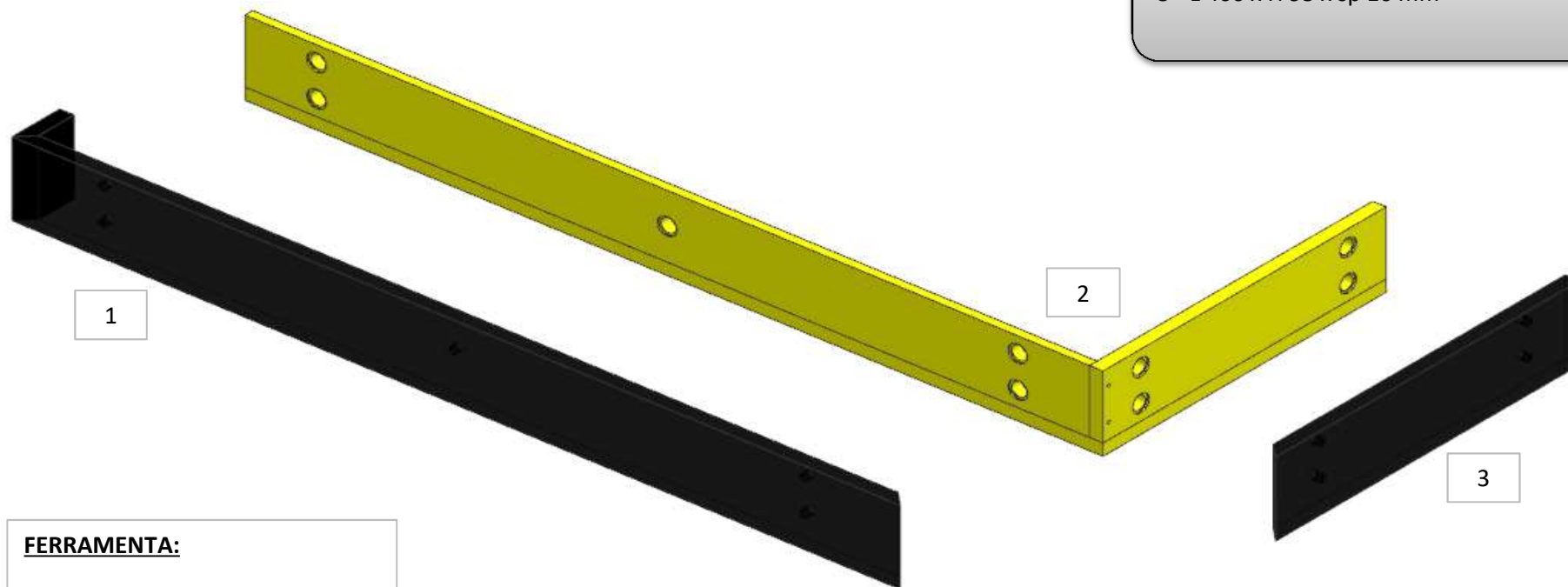

FERRAMENTA:
N° 9 - FAST MOUNT MASCHIO
N° 9 - FAST MOUNT FEMMINA
N°3- VITI 6MA