

# AZ68F

DA MAT. 216 REV. 29-04-2024

LOCALE	CODICE	DESCRIZIONE COMPONENTE	FINITURA	Q.TA	OPERATORE
CUCINA	AZ68F_R01_KA01	CUCINA MURATA	LASTRA CHIARA	6	Damiano

**1** **2**

**3** **4** **5** **6**

**240**  
MODIFICA SPESSORE ANTE  
N.1/2/3/4  
DA 20mm A 25mm

**ATTENZIONE!**  
**CONSEGNARE**  
**ANTA N.4 A**  
**PARTE E SENZA**  
**FORI CERNIERE**

1 - L 169.5 x H 774 x sp 25 mm  
2 - L 595 x H 163 x sp 25 mm  
3 - L 595 x H 147 x sp 25 mm  
4 - L 550 x H 774 x sp 25 mm  
5 - L 566 x H 62.5 x sp 16 mm  
6 - L 566 x H 58 x sp 16 mm

**ELEMENTO DA MONTARE con:**  
**L01\_KA01**  
**P01\_KA01**  
**KA01**  
e spedire con un unico imballo

**ID 1417**  
**ATTENZIONE!**  
NON FORARE PER CALAMITE ANTA  
N.4 - CONSEGNARE CALAMITE  
SCIOLTE

**241**  
MODIFICA FINITURA ZOCOLI  
DA TEAK A LASTRA CHIARA

L01\_KA01  
P01\_KA01  
KA01

# AZ68F

DA MAT. 216 REV. 29-04-2024

LOCALE	CODICE	DESCRIZIONE COMPONENTE	FINITURA	Q.TA	OPERATORE
CUCINA	AZ68F_R01_KB01	BASE CUCINA PRUA	LASTRA CHIARA	6	Damiano

- 1 - L 96.5 x H 774 x sp 32 mm
- 2 - L 317 x H 774 x sp 25 mm
- 3 - L 438 x H 774 x sp 25 mm
- 4 - L 438 x H 18 x 20 mm
- 5 - L 438 x H 207 x 25 mm
- 6 - L 433 x H 90 x 16 mm

**240**  
MODIFICA SPESSORE ANTE  
N.2/3/5  
DA 20mm A 25mm

ELEMENTO DA MONTARE:  
MF-KB01  
MF-KB02  
e spedire con un unico imballo

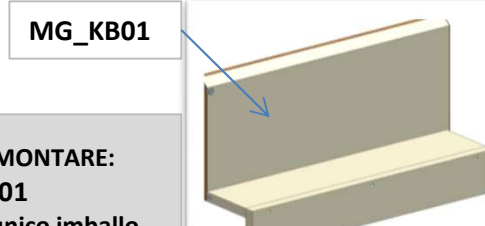
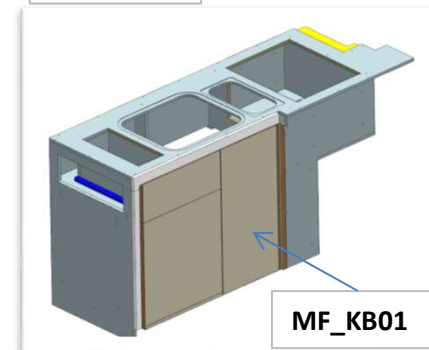
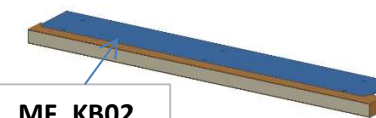
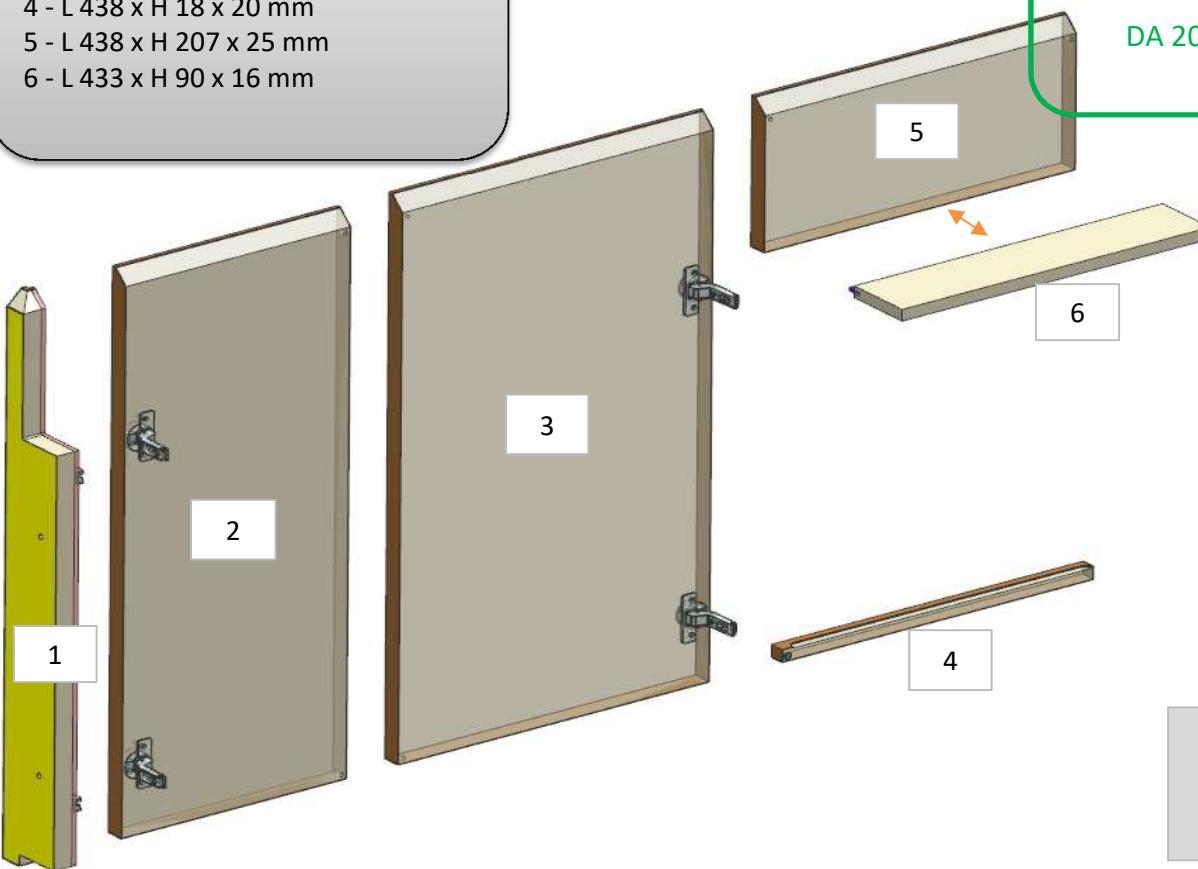

ELEMENTO DA MONTARE:  
MG-KB01  
e spedire con un unico imballo

**consonni&c**

# AZ68F

DA MAT.216

REV. 29-04-2024

LOCALE	CODICE	DESCRIZIONE COMPONENTE	FINITURA	Q.TA	OPERATORE
CUCINA	AZ68F_R01_KD01	STRUTTURA A L ZOCCOLO	LASTRA CHIARA	2	Damiano

1 - L 819 x H 62.5 x sp 16 mm  
2 - L 802 x H 62.5 x sp 16 mm

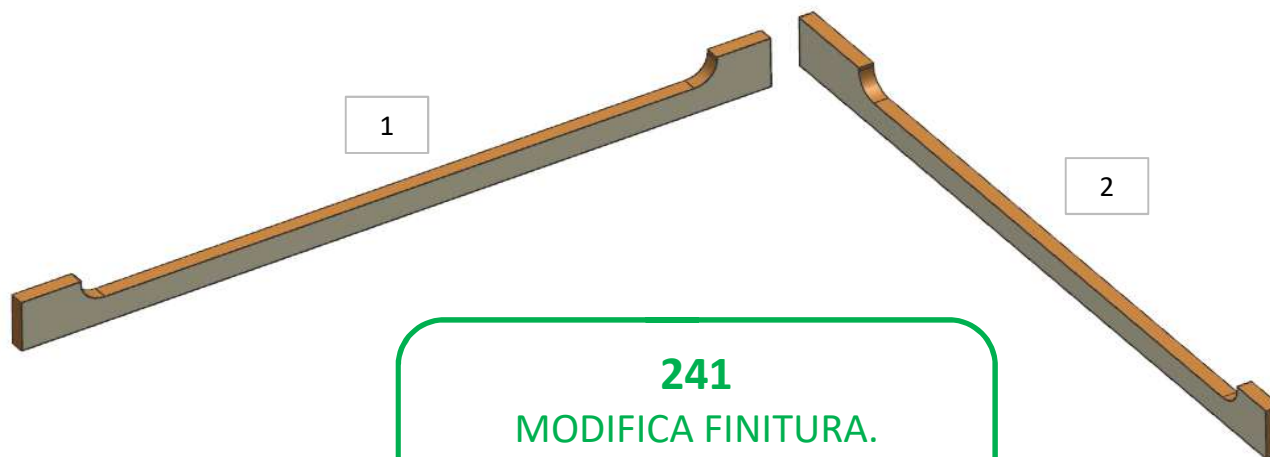

**241**  
MODIFICA FINITURA.  
DA TEAK A LASTRA CHIARA

ELEMENTO DA MONTARE con:  
**KD01**  
e spedire con un unico imballo

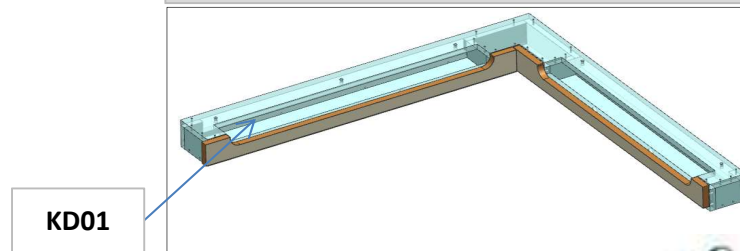

consonni&c

# AZ68F

DA MAT. 201 REV. 29-04-2024

LOCALE	CODICE	DESCRIZIONE COMPONENTE	FINITURA	Q.TA	OPERATORE
CUCINA	AZ68F-R01_KG01	PLENUM PENSILE	LASTRA CHIARA	2	Damiano

1 - L 1005 x H 97 x sp 16 mm  
2 - L 1523 x H 97 x sp 16 mm

**240**  
MODIFICA FINITURA DA TEAK A  
LASTRA CHIARA

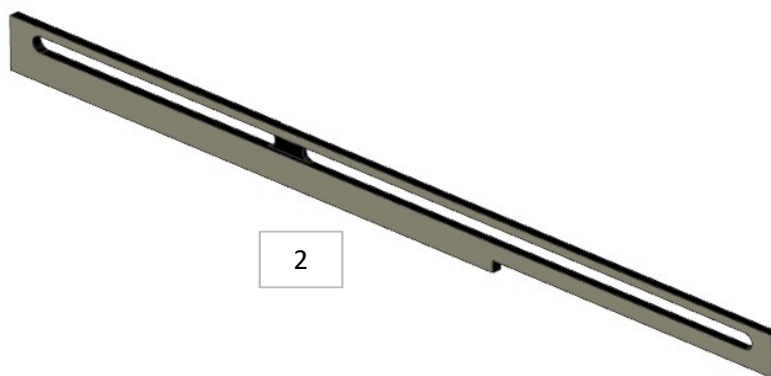
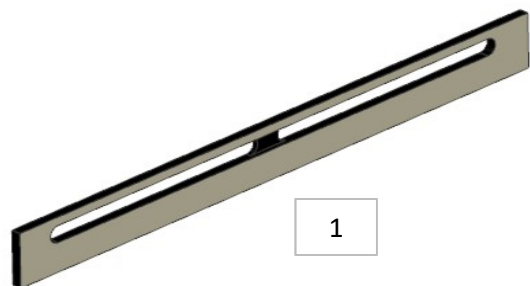

ELEMENTO DA MONTARE con:  
**X01\_KG01**  
e spedire con un unico imballo

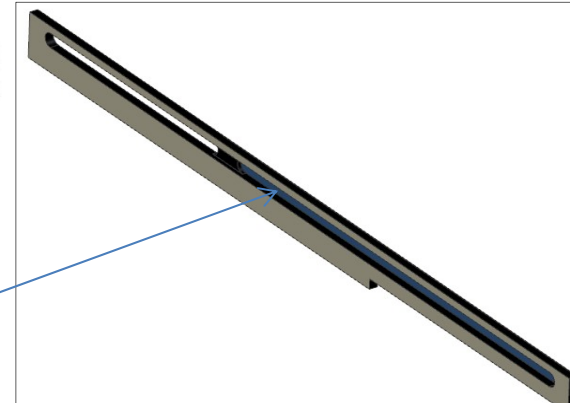

X01\_KG01

consonni&c

# AZ68F

DA MAT. 265 REV. 29-04-2024

LOCALE	CODICE	DESCRIZIONE COMPONENTE	FINITURA	Q.TA	OPERATORE
CUCINA	AZ68F-R01_KH01	PARETE TV E LATO GUIDA	LASTRA CHIARA	2	Damiano

1 - L 885 x H 1340 x sp 25 mm  
2 - L 885 x H 32 x sp 20 mm

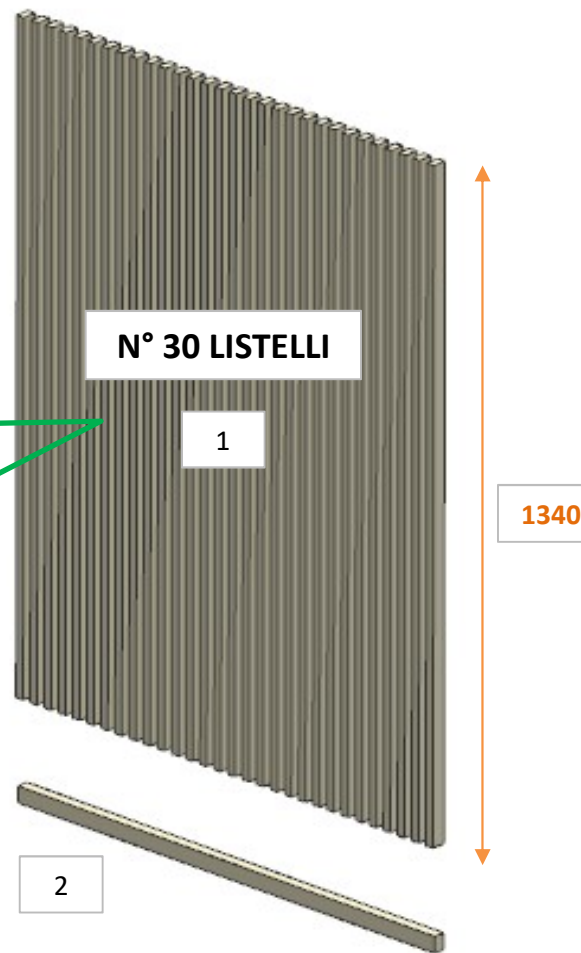

ELEMENTO DA MONTARE con:  
**MF\_KH05**  
e spedire con un unico imballo

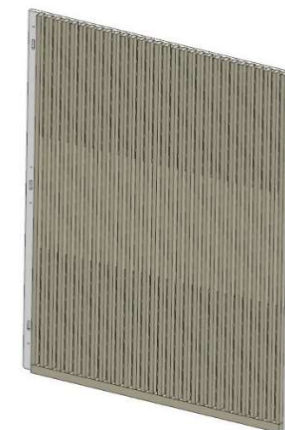

consonni&c

# AZ68F

DA MAT. 265 REV. 29-04-2024

LOCALE	CODICE	DESCRIZIONE COMPONENTE	FINITURA	Q.TA	OPERATORE
CUCINA	AZ68F-R02_KH01	PARETE TV E LATO GUIDA	LASTRA TEAK	4	Damiano

- 1 - L 883 x H 43 x sp 6 mm
- 2 - L 430 x H 43 x sp 6 mm
- 3 - L 883 x H 43 x sp 6 mm
- 4 - L 430 x H 43 x sp 6 mm

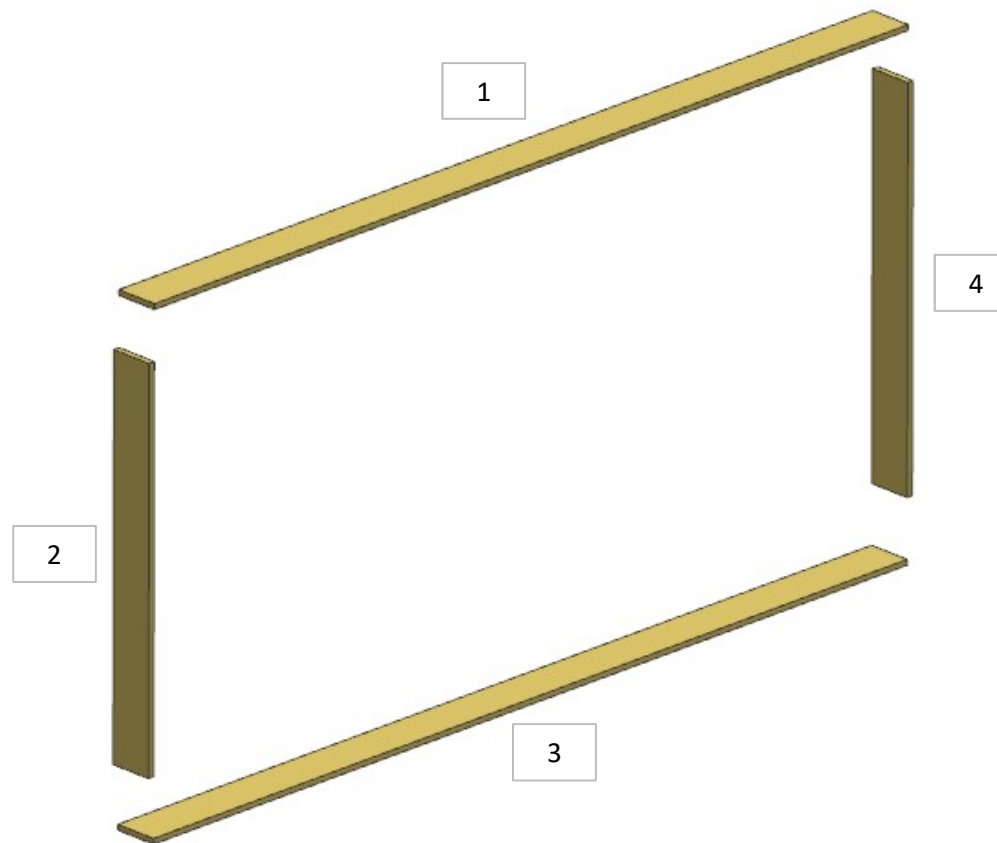

# AZ68F

DA MAT. 216 REV. 29-04-2024

LOCALE	CODICE	DESCRIZIONE COMPONENTE	FINITURA	Q.TA	OPERATORE
CUCINA	AZ68F-R01_KI01	PARETE POPPA LANTERNA-OPT	LASTRA CHIARA	2	Damiano

1 - L 530 x H 682.5 x 28.5 mm  
2 - L 595 x H 872 x 29 mm

**ID1252-232**  
MODIFICA SAGOMA PER  
ACCOPIAMENTO CON  
VETRORESINA

CUCINA CHIUSA

ELEMENTO DA MONTARE con:  
**KI01**  
**R02\_KI01**  
**L01\_KI01**  
**X01\_KI01**  
e spedire con un unico imballo

R02\_KI01

X01\_KI01

L01\_KI01

KI01

consonni&c

# AZ68F

DA MAT. 207 REV. 29-04-2024

LOCALE	CODICE	DESCRIZIONE COMPONENTE	FINITURA	Q.TA	OPERATORE
CUCINA	AZ68F-R02_KI01	PARETE POPPA LANTERNA-OPT	LASTRA TEAK	3	Damiano

1 - L 797.5 x H 340 x sp 6 mm  
2 - L 595 x H 36 x 20 mm  
3 - L 530.5 x H 36 x 20 mm

**ID-1466**  
DA 211 VERIFICARE  
SENSO VENA E  
SPESSORE

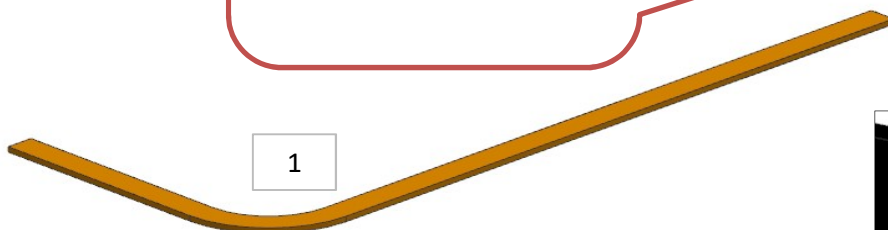

**66**  
VERIFICARE CHE I  
TEACK SIANO FATTI IN  
UN PEZZO UNICO

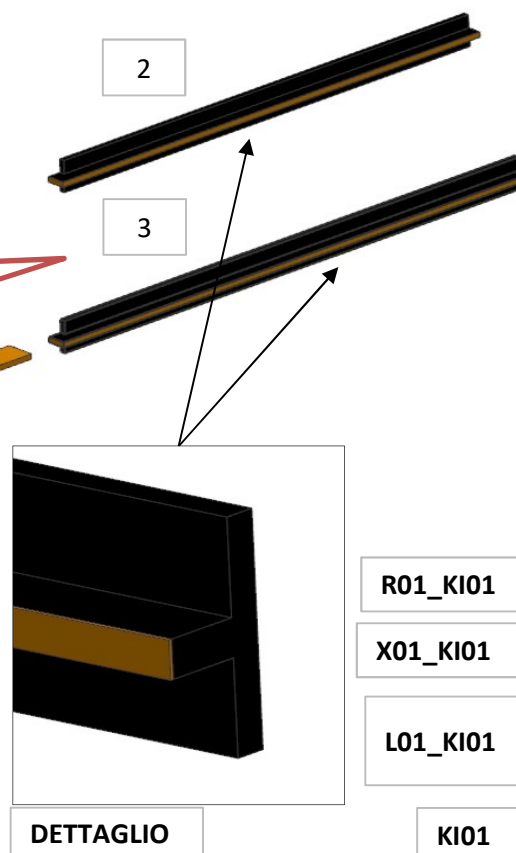

ELEMENTO DA MONTARE con:  
**KI01**  
**R01\_KI01**  
**L01\_KI01**  
**X01\_KI01**  
e spedire con un unico imballo

R01\_KI01

X01\_KI01

L01\_KI01

KI01

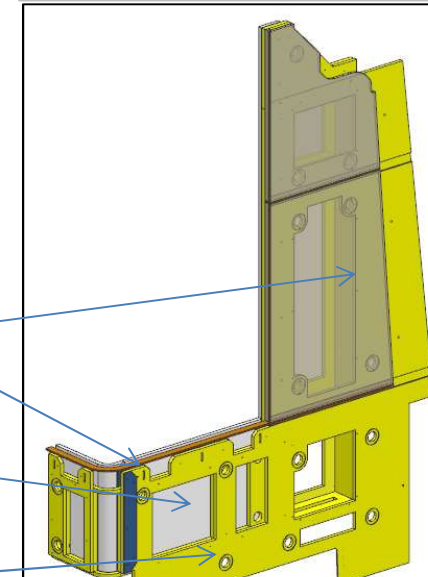

consonni&c

# AZ68F

DA MAT. 237 REV. 29-04-2024

LOCALE	CODICE	DESCRIZIONE COMPONENTE	FINITURA	Q.TA	OPERATORE
CUCINA	AZ68F-R01_KM01	PANNELLI FINESTRATURA	LASTRA CHIARA	3	Damiano

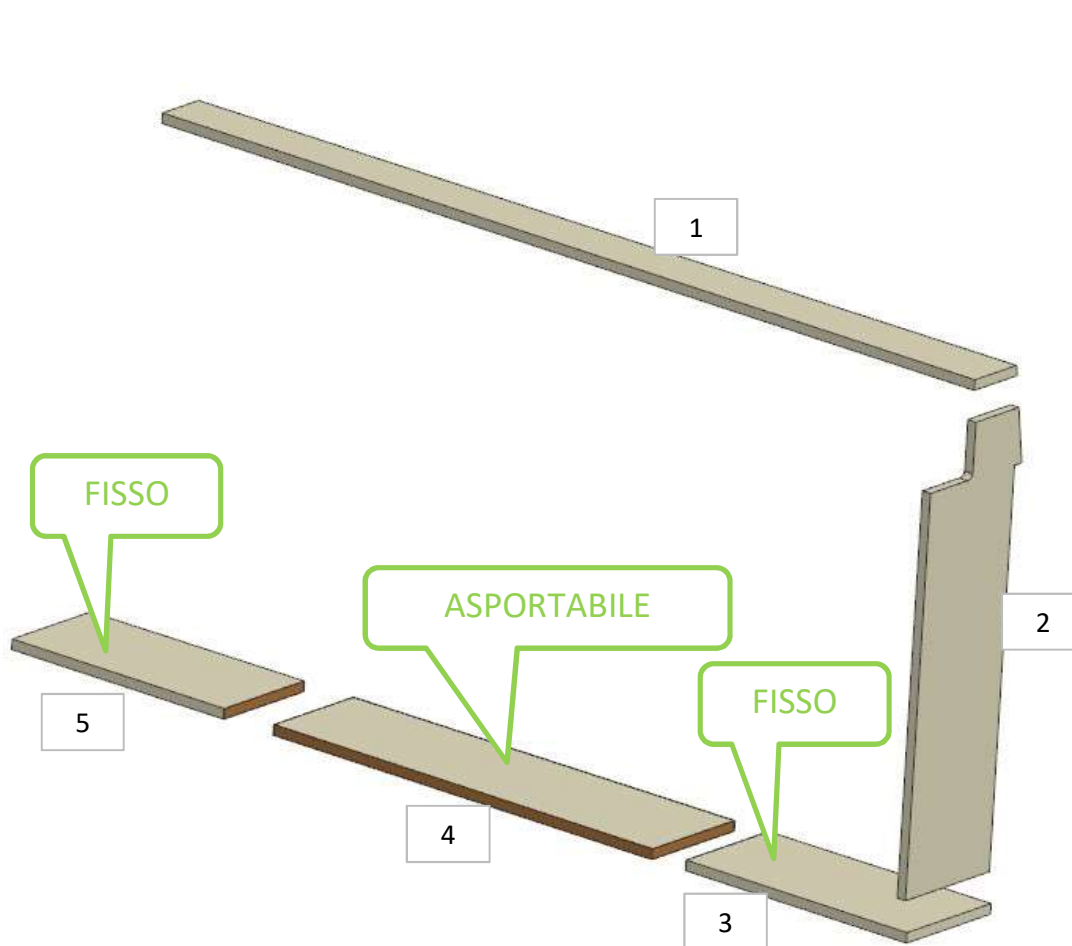

- 1 - L 1587.5 x H 74.5 x sp 16 mm
- 2 - L 150.5 x H 701 x sp 16 mm
- 3 - L 431 x H 150/153 x sp 16 mm
- 4 - L 740 x H 145/150 x sp 16 mm
- 5 - L 415 x H 143/145 x sp 16 mm

ELIMINATE  
VASCHETTE PORTA  
SAPONE

**FERRAMENTA:**  
N° 6 - RICONTRIO SOUTHCO S

# AZ68F

REV. 29-04-2024

LOCALE	CODICE	DESCRIZIONE COMPONENTE	FINITURA	Q.TA	OPERATORE
CUCINA	AZ68F-R01_KN01	FRIGO	LASTRA CHIARA	11	Damiano

**240**  
MODIFICATO SP. ANTE. DA  
20 a 25mm

**211**  
DIVISIONE SPALLA N.5 IN 2  
PEZZI

- 1 - L 98 x H 1988 x sp 16 mm
- 2 - L 695 x H 1863 x sp 25 mm
- 3 - L 683 x H 83 x sp 16 mm
- 4 - L 683 x H 77 x 16 mm
- 5 - L 505.5 x H 1634 x 32 mm
- 6 - L 246 x H 822 x sp 16 mm
- 7 - L 695 x H 220 x sp 25 mm
- 8 - L 651 x H 47 x sp 16 mm
- 9 - L 188 x H 77 x sp 16 mm
- 10 - L 317 x H 193 x sp 32 mm
- 11 - L 650 x H 40 x sp 16 mm

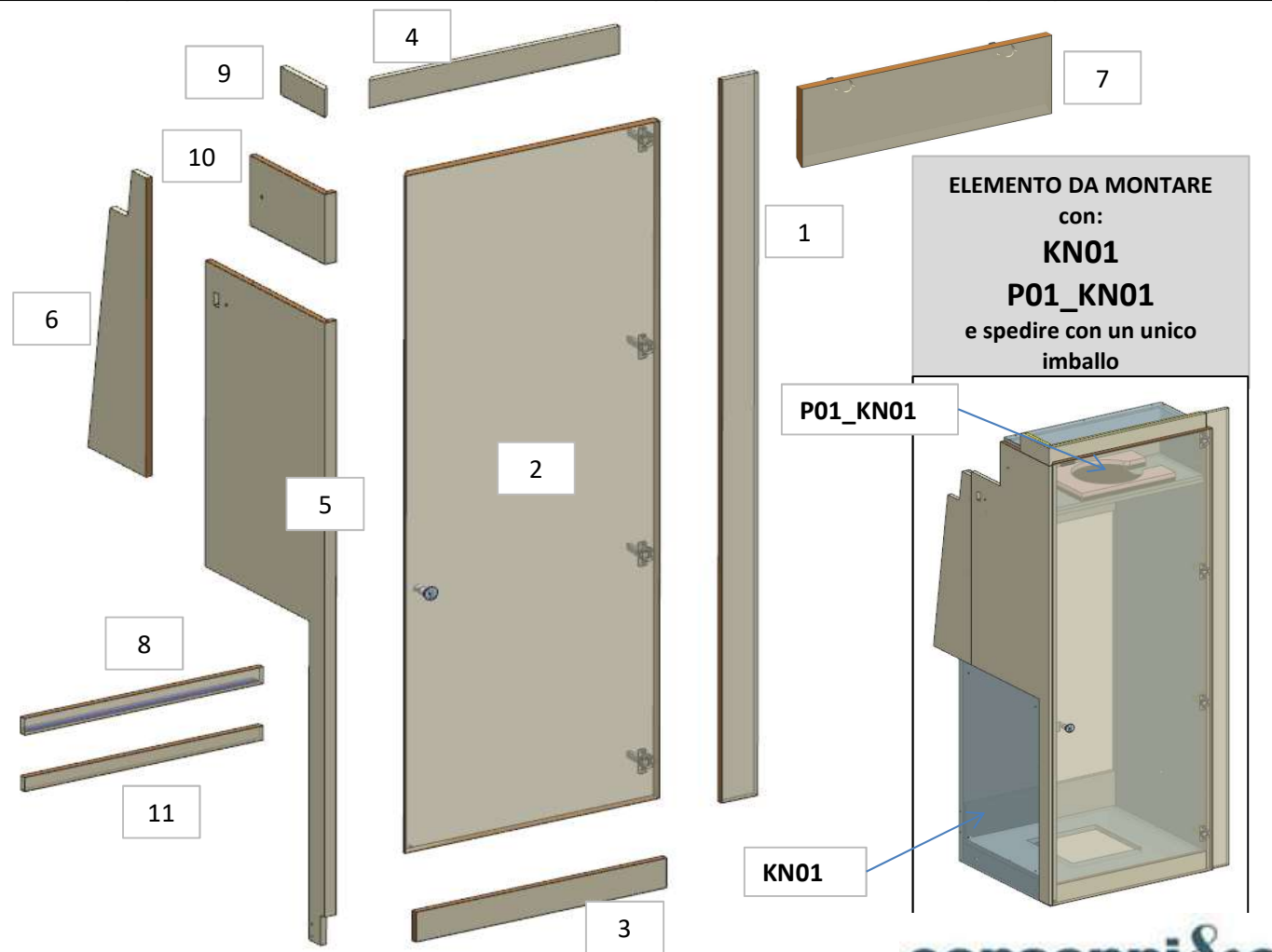

# AZ68F

DA MAT. 203 REV. 29-04-2024

LOCALE	CODICE	DESCRIZIONE COMPONENTE	FINITURA	Q.TA	OPERATORE
CUCINA	AZ68F-R01_KP01	DIVISORIO LANTERNA - OPT	LASTRA CHIARA	3	Damiano

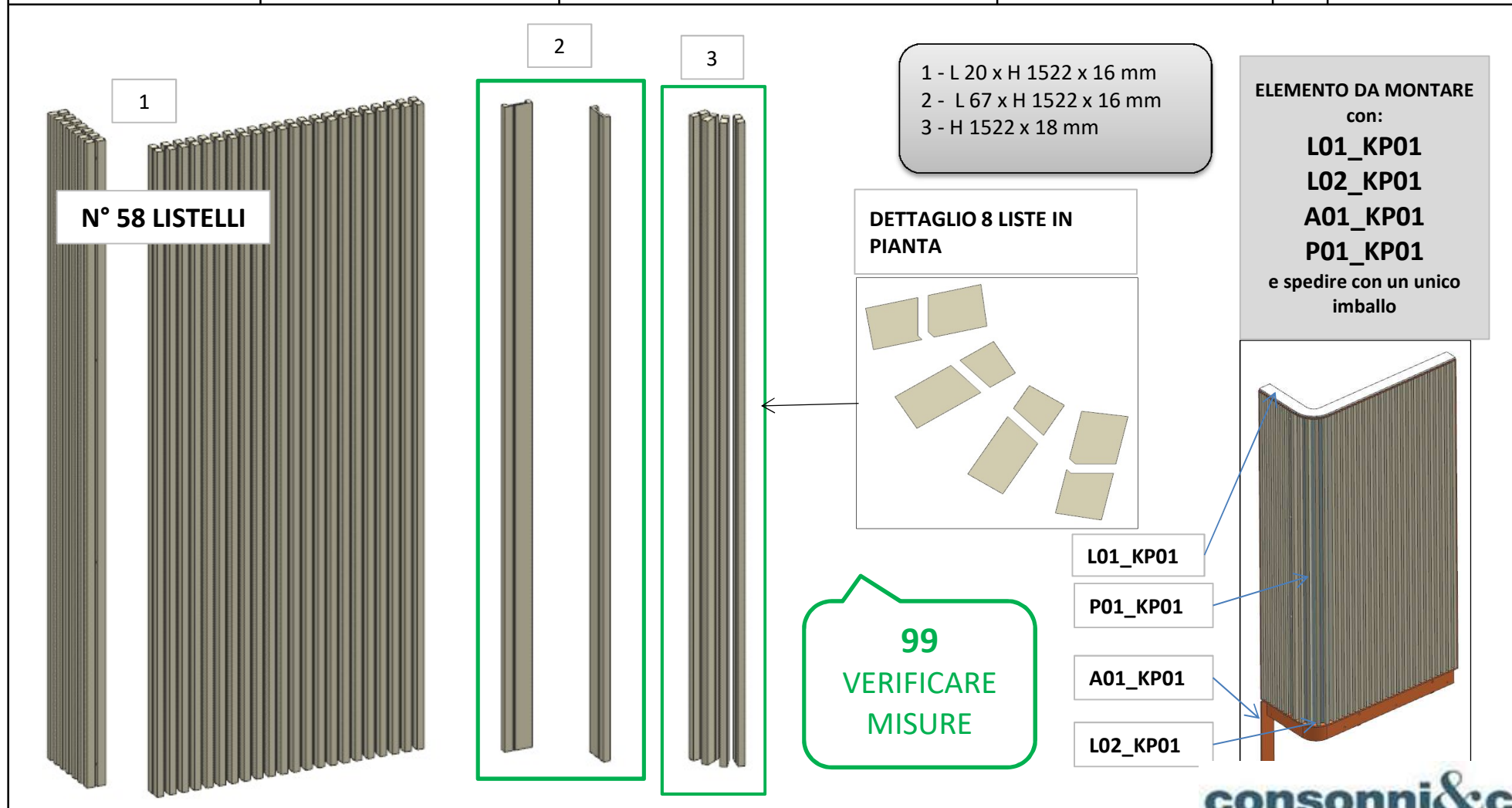

# AZ68F

DA MAT. 216 REV. 29-04-2024

LOCALE	CODICE	DESCRIZIONE COMPONENTE	FINITURA	Q.TA	OPERATORE
CUCINA	AZ68F-R01_KQ01	PARETE POPPA-STD	LASTRA CHIARA	2	Damiano

1 - L 530.5 x H 682.5 x sp 11 mm  
2 - L 595 x H 872 x sp 11 mm

**ID1252-232**  
MODIFICA SAGOMA PER  
ACCOPIAMENTO CON  
VETRORESINA

CUCINA APERTA

1

2

ELEMENTO DA MONTARE con:

**KQ01**

**R02\_KQ01**

**L01\_KQ01**

**X01\_KQ01**

e spedire con un unico imballo

R02\_KQ01

L01\_KQ01  
(RETRO)

X01\_KQ01

KQ01

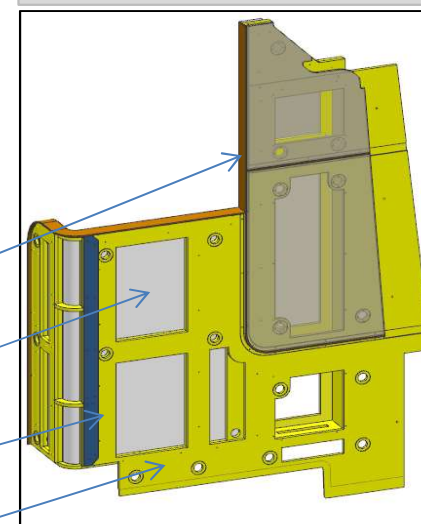

consonni&c

# AZ68F

DA MAT. 207 REV. 29-04-2024

LOCALE	CODICE	DESCRIZIONE COMPONENTE	FINITURA	Q.TA	OPERATORE
CUCINA	AZ68F-R02_KQ01	PARETE POPPA-STD	LASTRA TEAK	5	Damiano

- 1 - SVILUPPO 1285 x L 68 x sp 20 mm
- 2 - L 792 x H 68 x 20 mm
- 3 - L 68 x H 688 x 22 mm
- 4 - L 36 x H 530.5 x 20 mm
- 5 - SVILUPPO 1434 x L 68 x sp 20 mm

**da mat.207**  
PEZZI N.2/4/5 IN  
MDF LASTRA TEAK

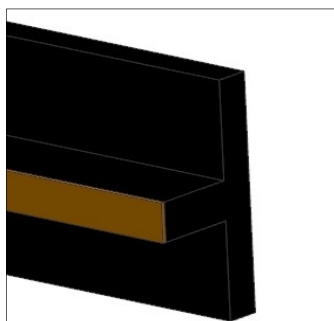

DETTAGLIO

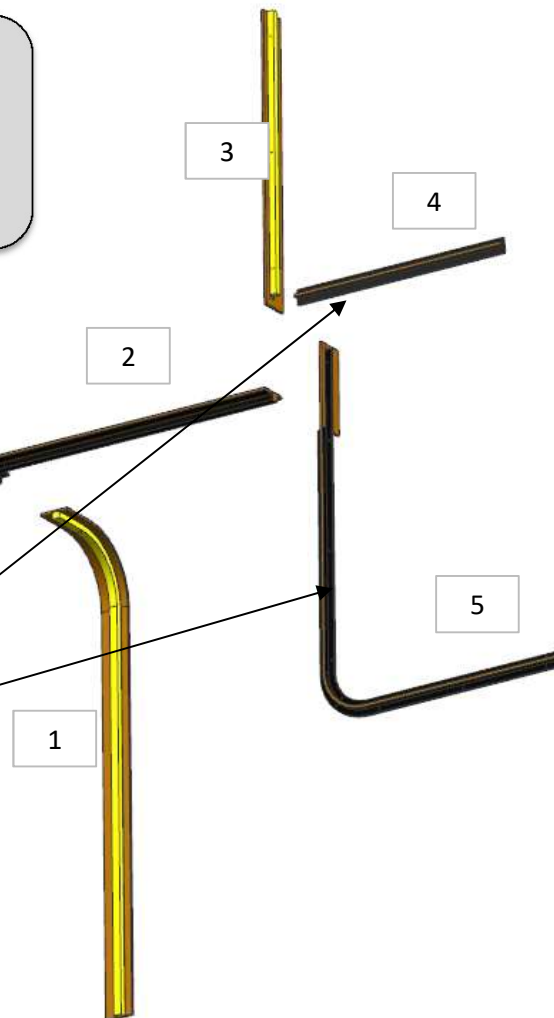

ELEMENTO DA MONTARE con:

**KQ01**

**R01\_KQ01**

**L01\_KQ01**

**X01\_KQ01**

e spedire con un unico imballo

R01\_KQ01

L01\_KQ01  
(RETRO)

X01\_KQ01

KQ01

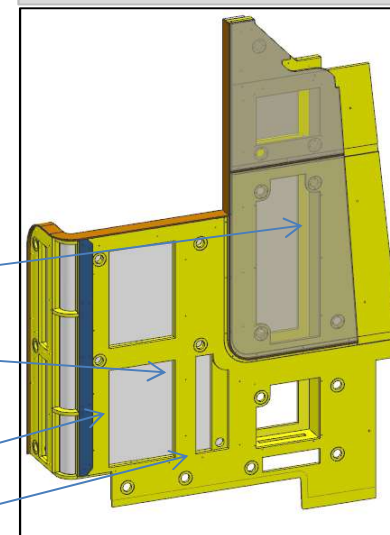

**consonni&c**