

AZ68F

DA MAT.201 REV. 20-04-2021

LOCALE	CODICE	DESCRIZIONE COMPONENTE	FINITURA	Q.TA	OPERATORE
CUCINA	AZ68F_X01_KB01	BASE CUCINA PRUA	LAMINATO NERO	1	Damiano

1 - L 419.5 x H 57 x sp 2 mm

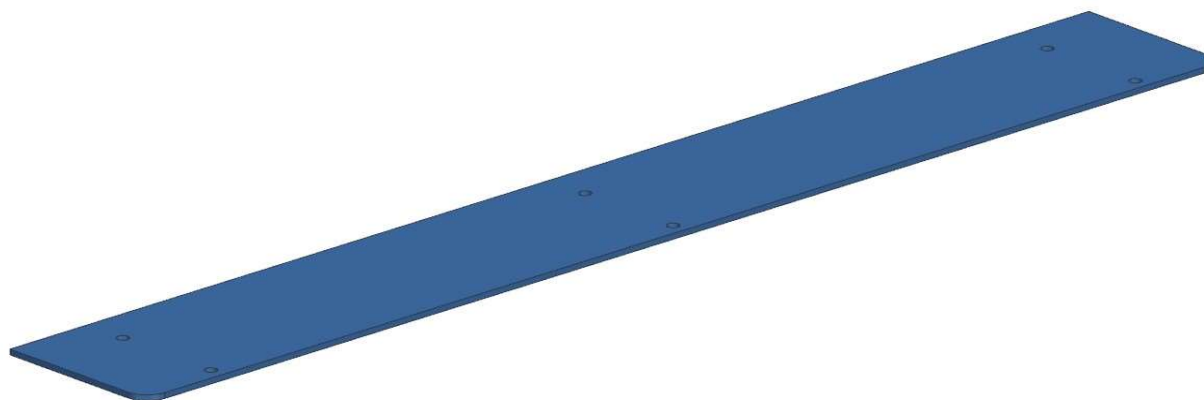

ELEMENTO DA MONTARE:
MF-KB01
MF-KB02
e spedire con un unico imballo

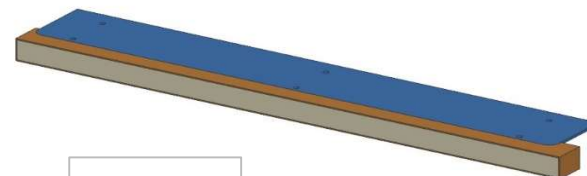

MF_KB02

consonni&c

AZ68F

REV. 20-04-2021

LOCALE	CODICE	DESCRIZIONE COMPONENTE	FINITURA	Q.TA	OPERATORE
CUCINA	AZ68F_X01_KC01	PIANO E ALZATE IN CORIAN	AVONITE	10	Damiano

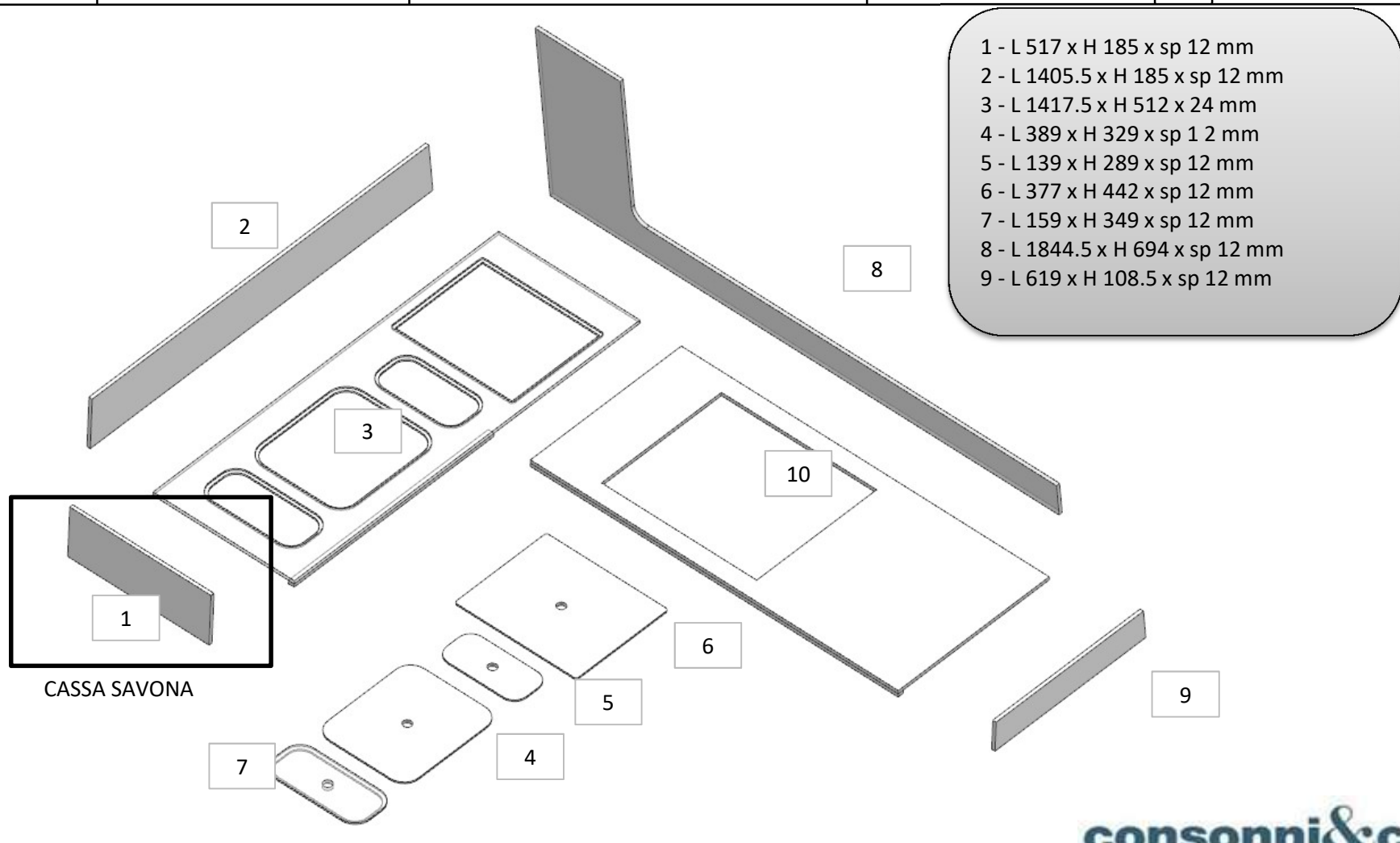

AZ68F

DA MAT.216

REV. 20-04-2021

LOCALE	CODICE	DESCRIZIONE COMPONENTE	FINITURA	Q.TA	OPERATORE
CUCINA	AZ68F-X01_KG01	PLENUM PENSILE	LAMINATO NERO	1	Damiano

1 - L 996.5 x H 59 x sp 1 mm

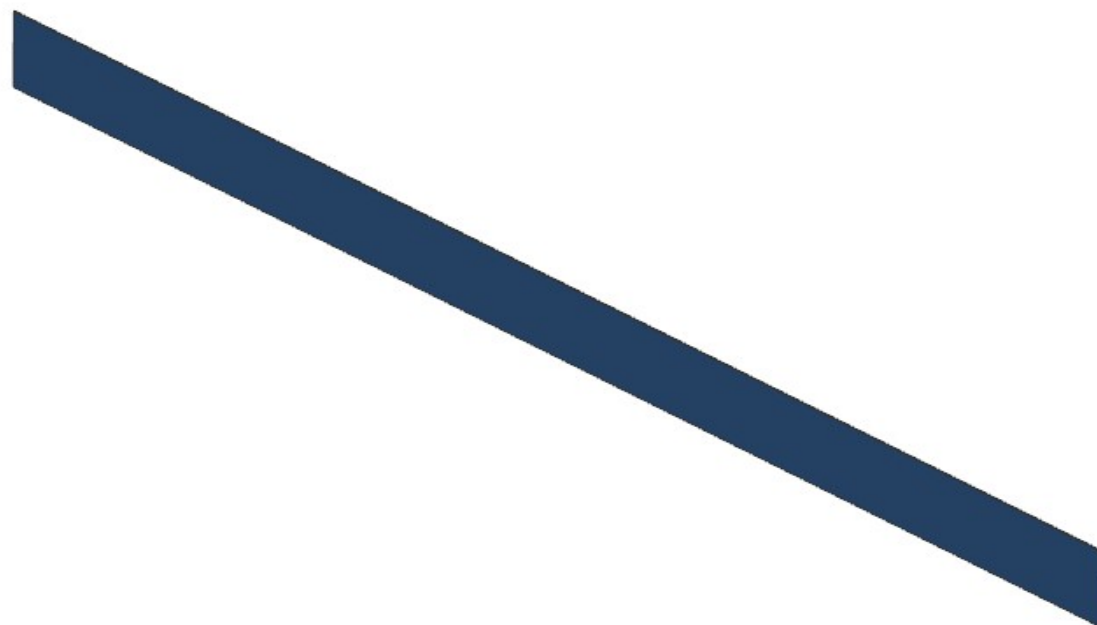

ELEMENTO DA MONTARE con:
R01_KG01
e spedire con un unico imballo

R01_KG01

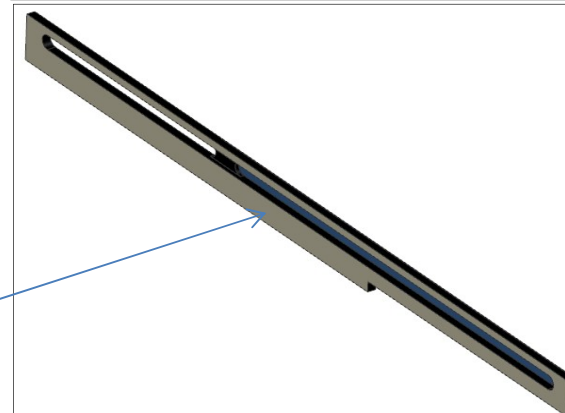

consonni&c

AZ68F

DA MAT. 203 REV. 20-04-2021

LOCALE	CODICE	DESCRIZIONE COMPONENTE	FINITURA	Q.TA	OPERATORE
CUCINA	AZ68F-X01_KI01	PARETE POPPA LANTERNA-OPT	LAMINATO NERO	2	Damiano

1 - L 60 x H 402 x sp 2 mm
2 - L 60 x H 402 x sp 2 mm

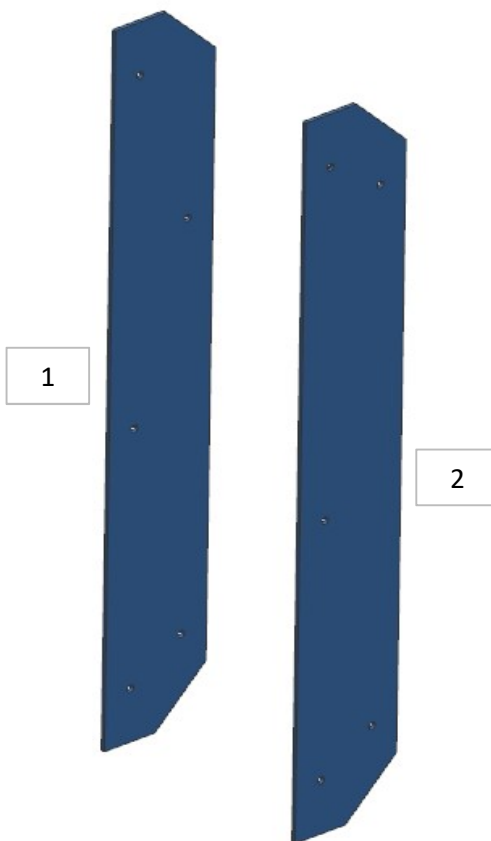

ELEMENTO DA MONTARE con:
KI01
R01_KI01
R02_KI01
L01_KI01
e spedire con un unico imballo

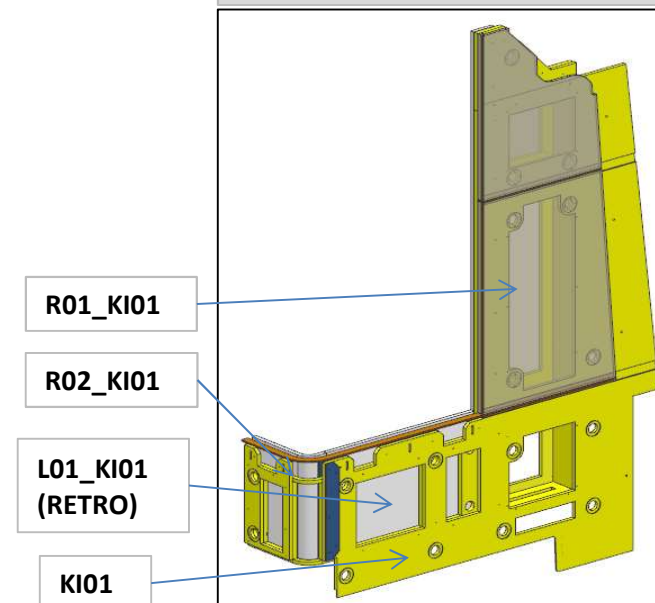

consonni&c

AZ68F

DA MAT. 203 REV. 20-04-2021

LOCALE	CODICE	DESCRIZIONE COMPONENTE	FINITURA	Q.TA	OPERATORE
CUCINA	AZ68F-X01_KQ01	PARETE POPPA-STD	LAMINATO NERO	2	Damiano

1 - L 60 x H 1098 x sp 2 mm
2 - L 60 x H 1098 x sp 2 mm

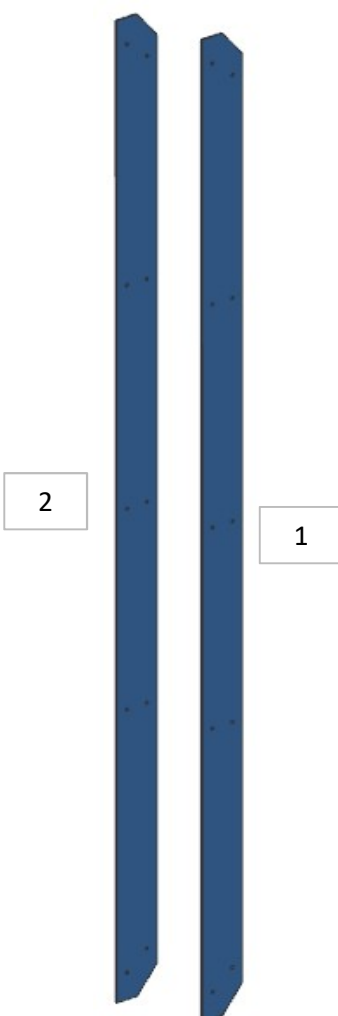

ELEMENTO DA MONTARE con:
KQ01
R01_KQ01
R02_KQ01
L01_KQ01
e spedire con un unico imballo

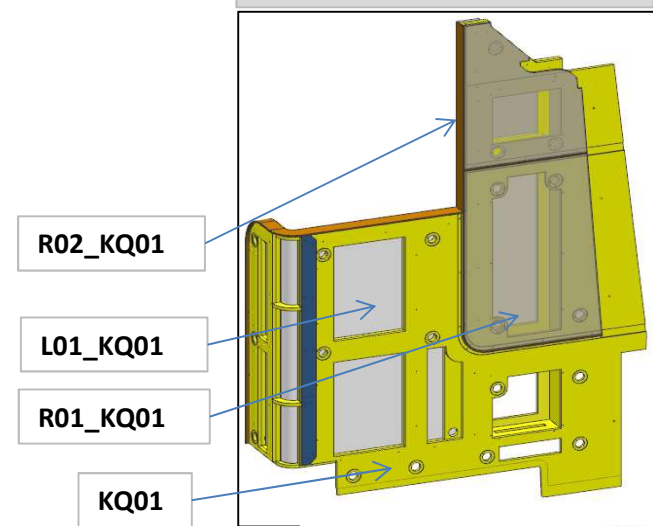

AZ68F

DA MAT. 201 REV. 20-04-2021

LOCALE	CODICE	DESCRIZIONE COMPONENTE	FINITURA	Q.TA	OPERATORE
CUCINA	AZ68F-X01_KS01	PAVIMENTO	LAMINATO OLIMPUS OL04	2	Damiano

1 - L 2160 x H 848 - 879 x sp 12
2 - L 305 x H 48 x sp 12

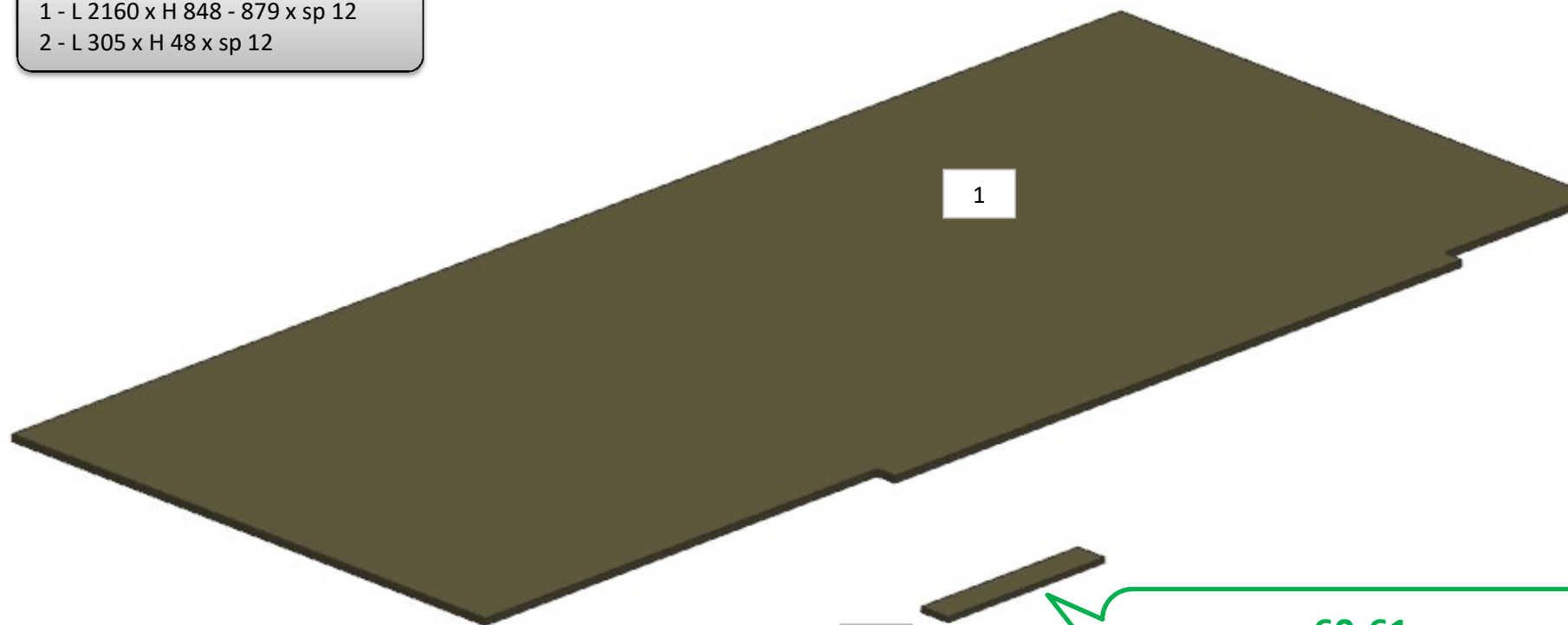

60-61
MODIFICATA SAGOMA E
AGGIUNTO PZ. n° 2