

AZ53F

REV. 26-06-2024

LOCALE	CODICE	DESCRIZIONE COMPONENTE	FINITURA	Q.TA	OPERATORE
SALONE	AZ53F-MF_SI01	TAVOLO STD			Damiano

86

AGGIUNTO TAVOLO

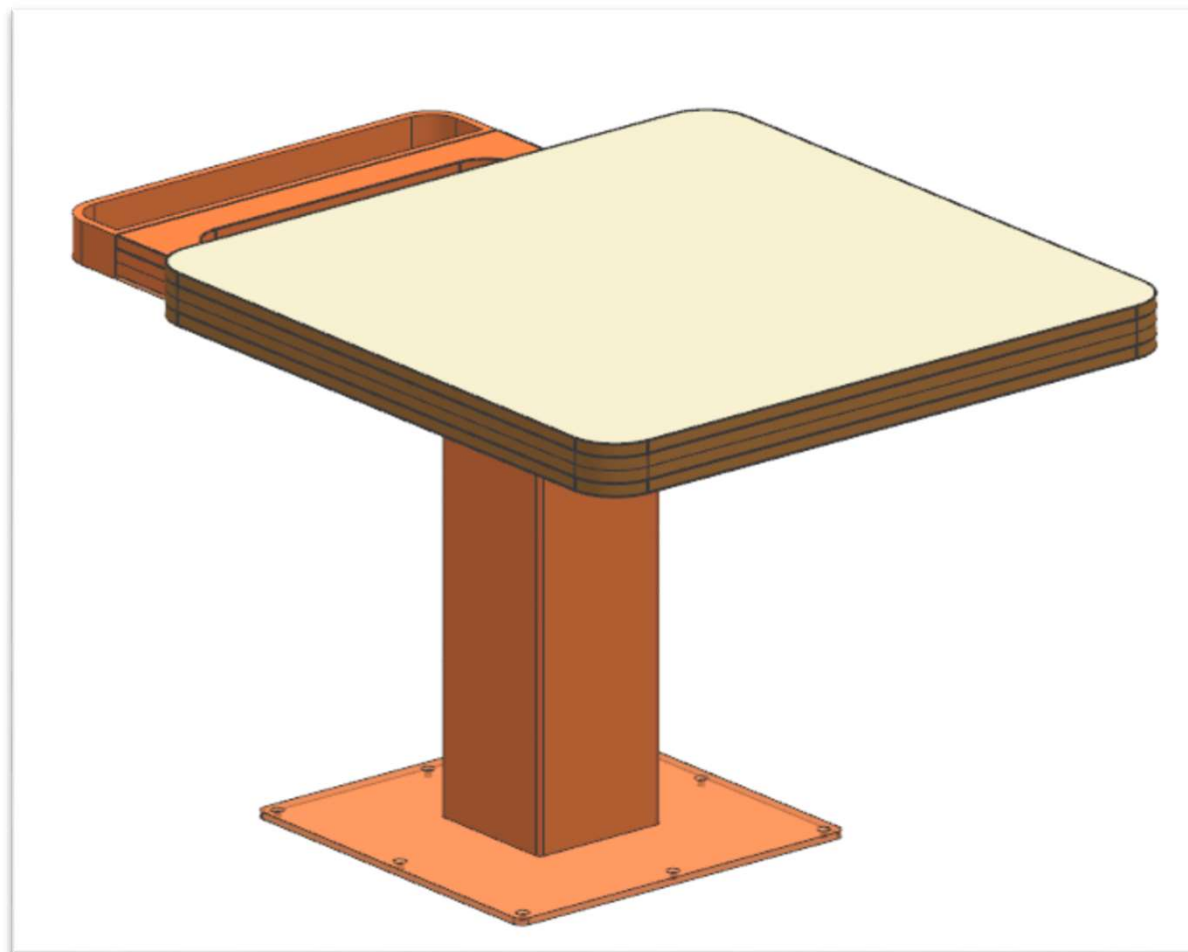

FERRAMENTA:

N° 14 - BUSSOLE ZAMA 6MA

AZ53F

DA MAT. 201 REV. 26-06-2024

LOCALE	CODICE	DESCRIZIONE COMPONENTE	FINITURA	Q.TA	OPERATORE
SALONE	AZ53F-R01_SI01	TAVOLO STD	LASTRA CHIARA	2	Damiano

1 - 2 - L. 700 x H. 700 x sp 30

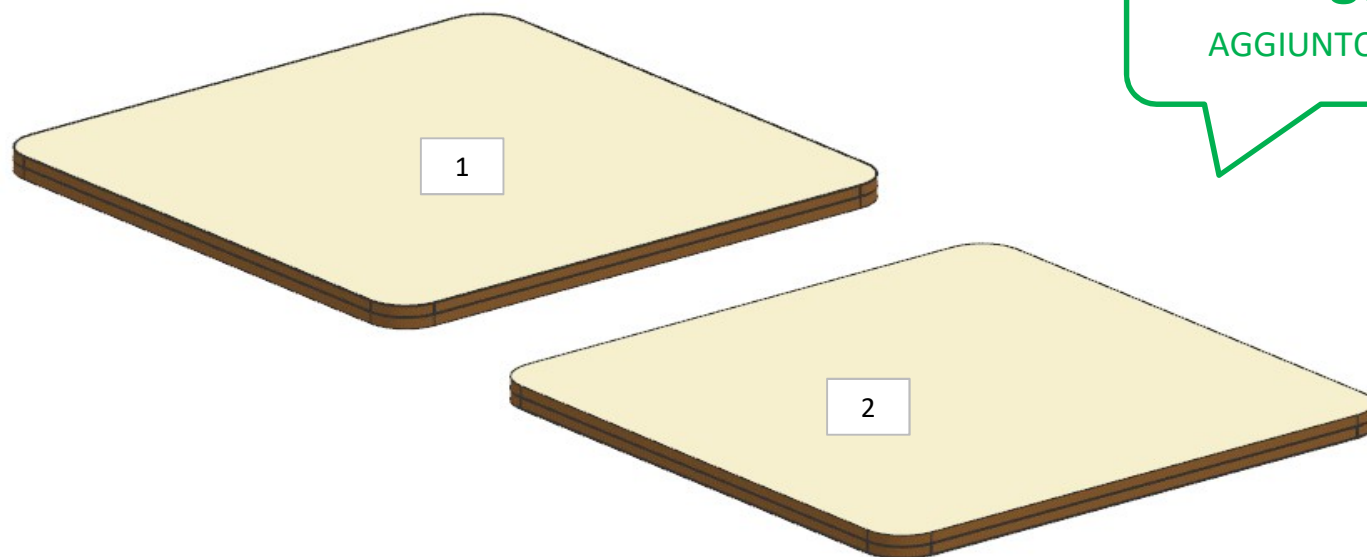

86
AGGIUNTO TAVOLO

ELEMENTO DA MONTARE con:
L01_SI01
I01_SI01
A01_SI01
e spedire con un unico imballo

FERRAMENTA:

N° 14 - BUSSOLE ZAMA 6MA

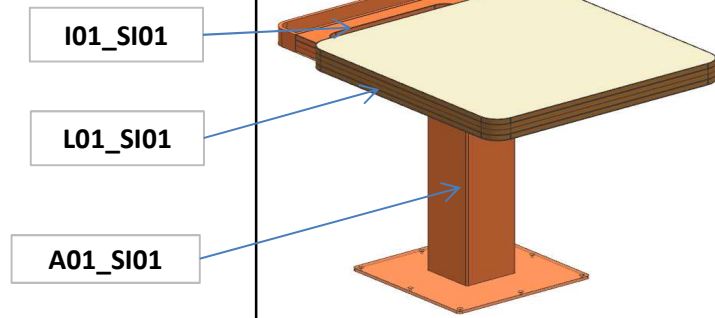

AZ53F

DA MAT. 201 REV. 26-06-2024

LOCALE	CODICE	DESCRIZIONE COMPONENTE	FINITURA	Q.TA	OPERATORE
SALONE	AZ53F-L01_SI01	TAVOLO STD	LACCATO BRONZO	1	Damiano

1 - L. 534 x H. 468 x sp 45

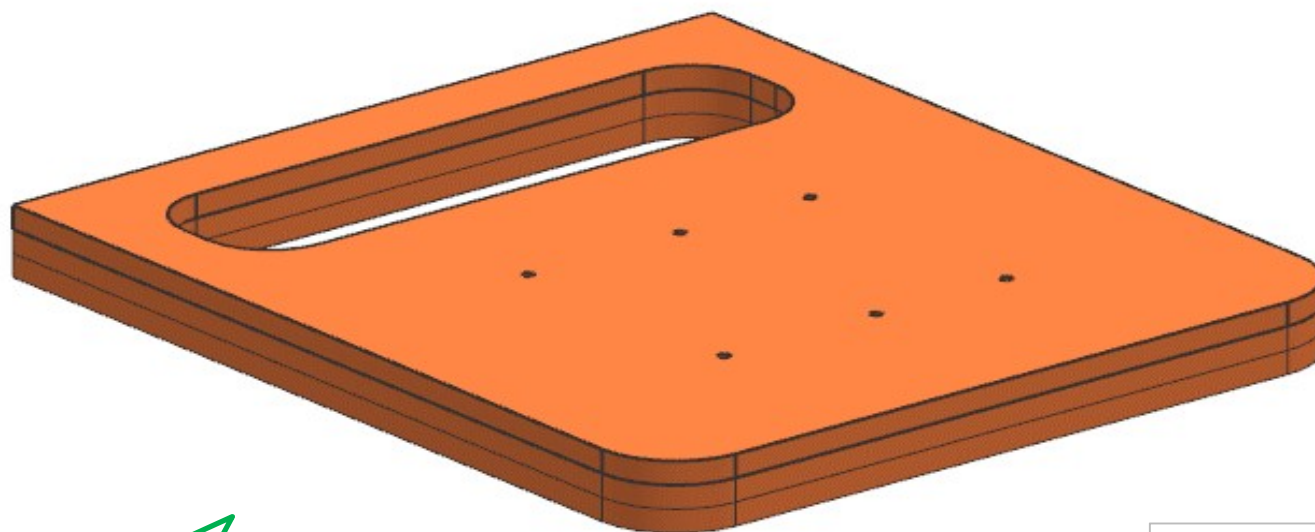

ELEMENTO DA MONTARE con:
R01_SI01
I01_SI01
A01_SI01
e spedire con un unico imballo

86
AGGIUNTO TAVOLO

I01_SI01

R01_SI01

A01_SI01

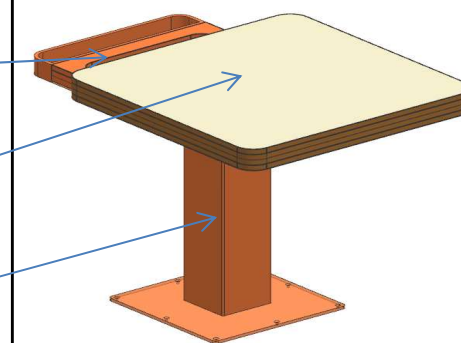

AZ53F

DA MAT. 201

REV. 26-06-2024

LOCALE	CODICE	DESCRIZIONE COMPONENTE	FINITURA	Q.TA	OPERATORE
SALONE	AZ53F-I01_SI01	TAVOLO STD	OKOUME' GREZZO	1	Damiano

1 - L. 375 x H. 95 x sp 10

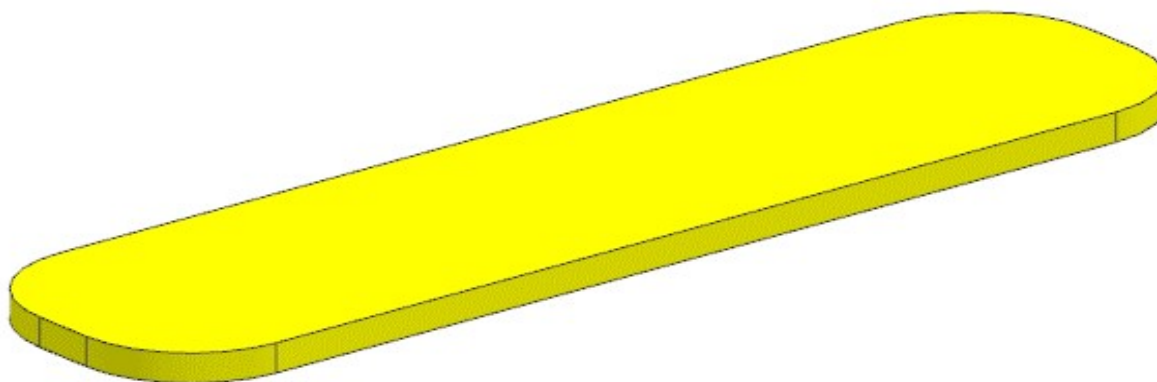

86
AGGIUNTO TAVOLO

ELEMENTO DA MONTARE con:
R01_SI01
L01_SI01
A01_SI01
e spedire con un unico imballo

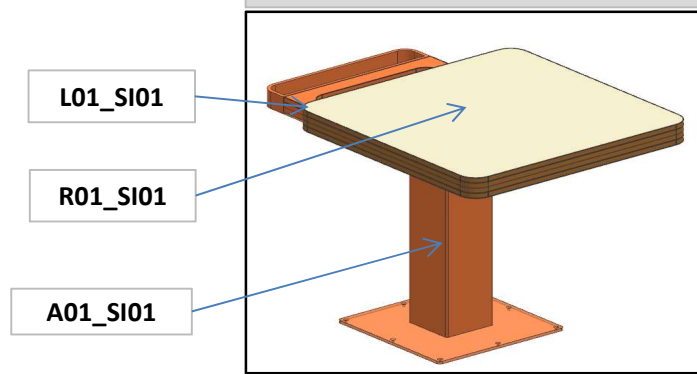

AZ53F

DA MAT. 201 REV. 26-06-2024

LOCALE	CODICE	DESCRIZIONE COMPONENTE	FINITURA	Q.TA	OPERATORE
SALONE	AZ53F-A01_SI01	TAVOLO STD	ACCIAIO VERNICIATO BRONZO	2	Damiano

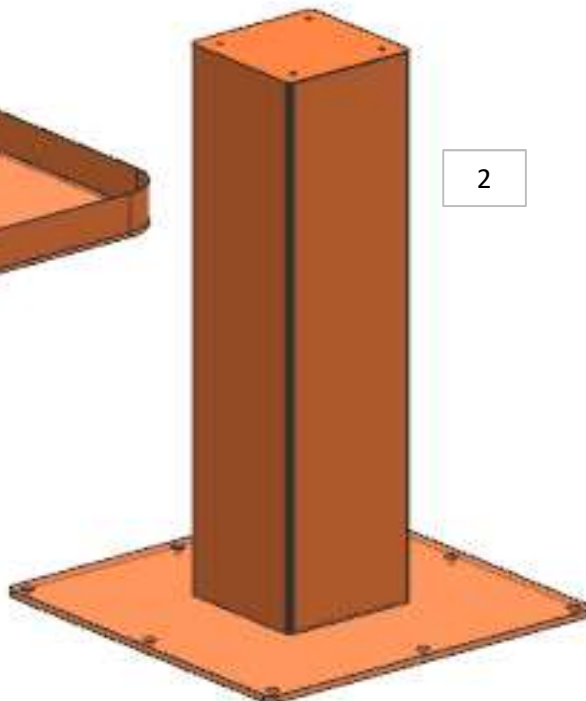
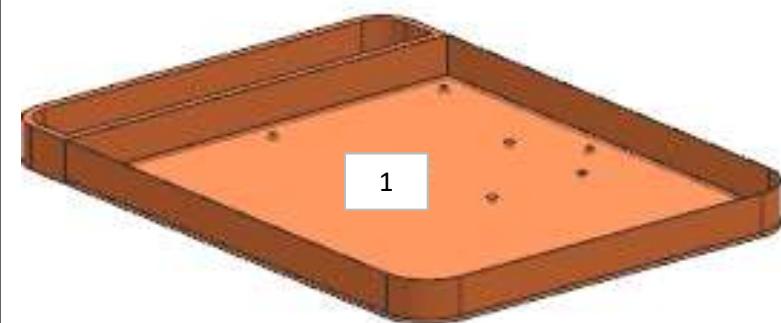

86
AGGIUNTO TAVOLO

ELEMENTO DA MONTARE con:
R01_SI01
I01_SI01
L01_SI01
e spedire con un unico imballo

