

# AZ53F

DA MAT. 201 REV. 26-06-2024

LOCALE	CODICE	DESCRIZIONE COMPONENTE	FINITURA	Q.TA	OPERATORE
FRONTE MARCIA	AZ53F-MF_FA01	PANNELLI GIRO SCALA			Dante

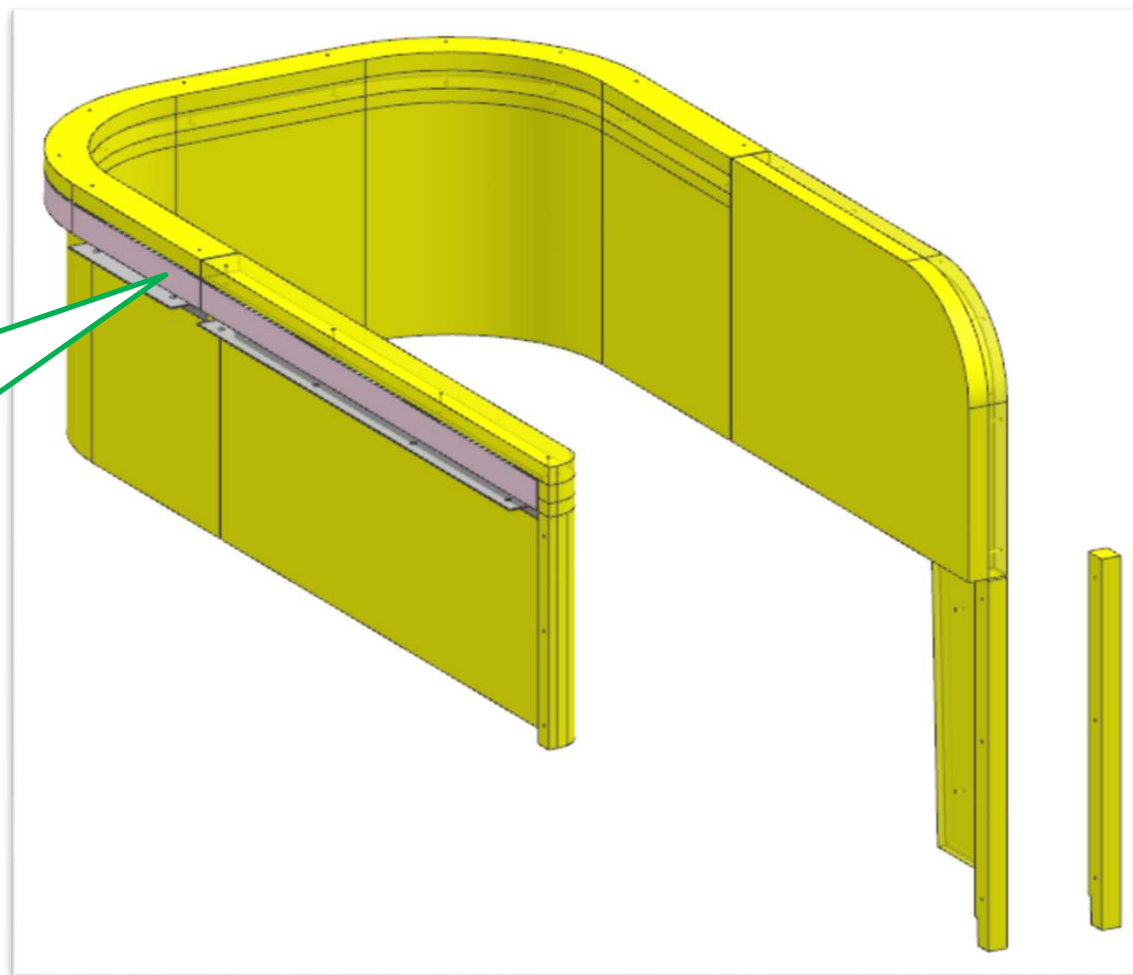

**99**

AGGIUNTI 2 pezzi FLEX -  
"APPUNTARE" ALLA STRUTTURA  
PRIMA DI SPEDIRE

**FERRAMENTA:**

- VELCRO

# AZ53F

DA MAT. 279 REV. 26-06-2024

LOCALE	CODICE	DESCRIZIONE COMPONENTE	FINITURA	Q.TA	OPERATORE
FRONTE MARCIA	AZ53F-I01_FA01	PANNELLO GIRO SCALA	OKOUME' GREZZO	6	Dante

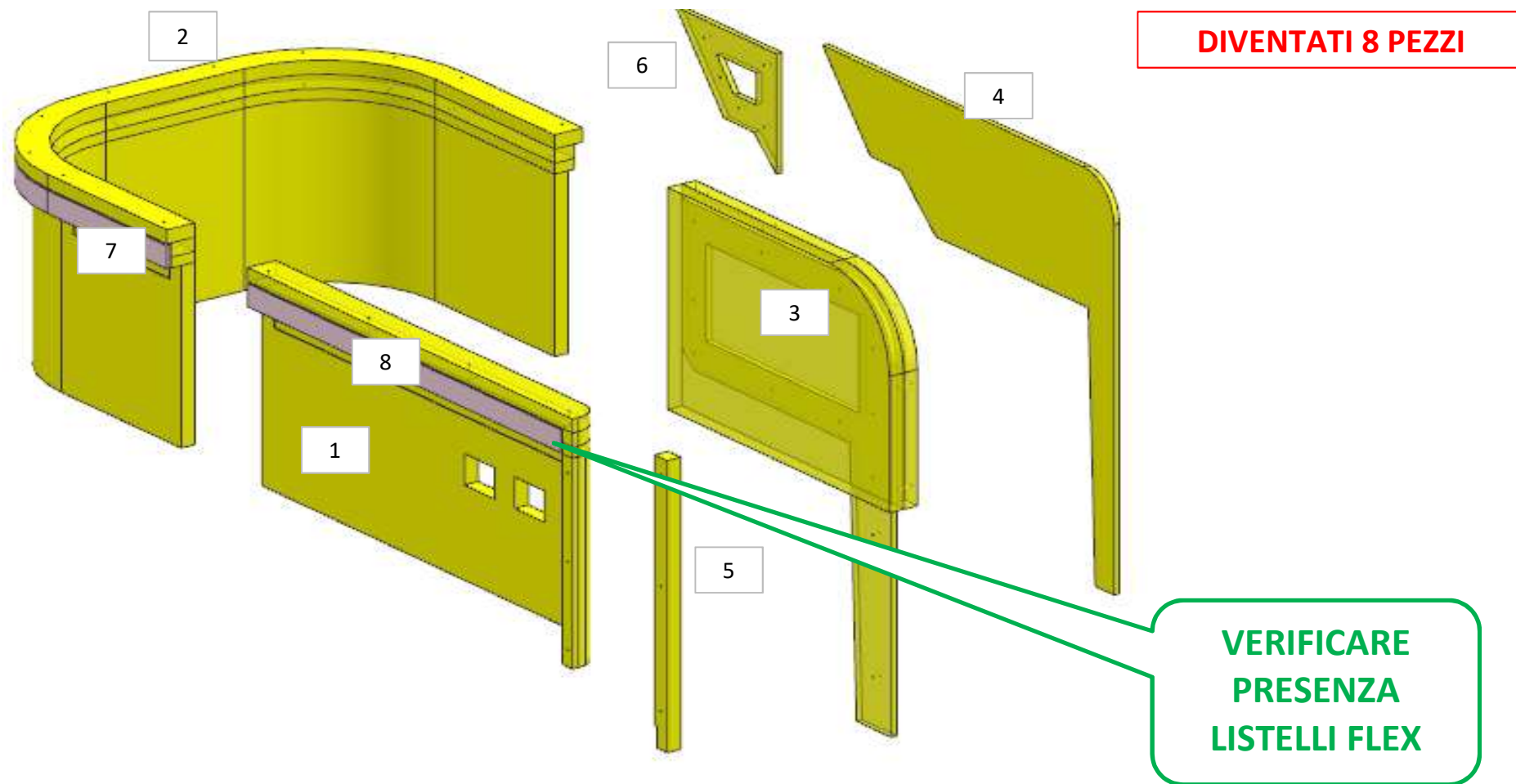

# AZ53F

DA MAT. 221 REV. 26-06-2024

LOCALE	CODICE	DESCRIZIONE COMPONENTE	FINITURA	Q.TA	OPERATORE
FRONTE MARCIA	AZ53F-I01_FB01	PANNELLI ANTIRIFLESSO	OKOUME' GREZZO	3	Dante

2 - L 1322 x H.1044 x sp 10

**199**

MODIFICA SECONDO  
DIMA

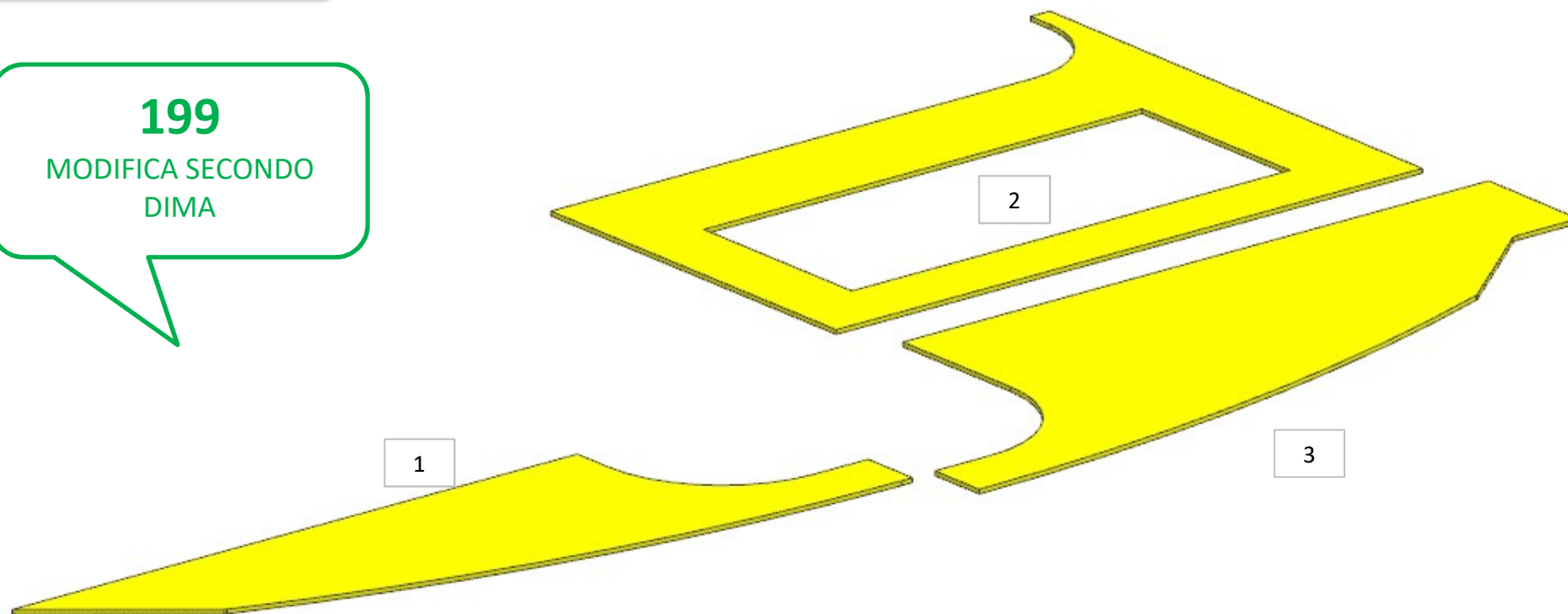

# AZ53F

DA MAT. 221 REV. 26-06-2024

LOCALE	CODICE	DESCRIZIONE COMPONENTE	FINITURA	Q.TA	OPERATORE
FRONTE MARCIA	AZ53F-MF_FC01	CONNTENITORE PORTA BICCHIERI ANTIRIFLESSO			Damiano

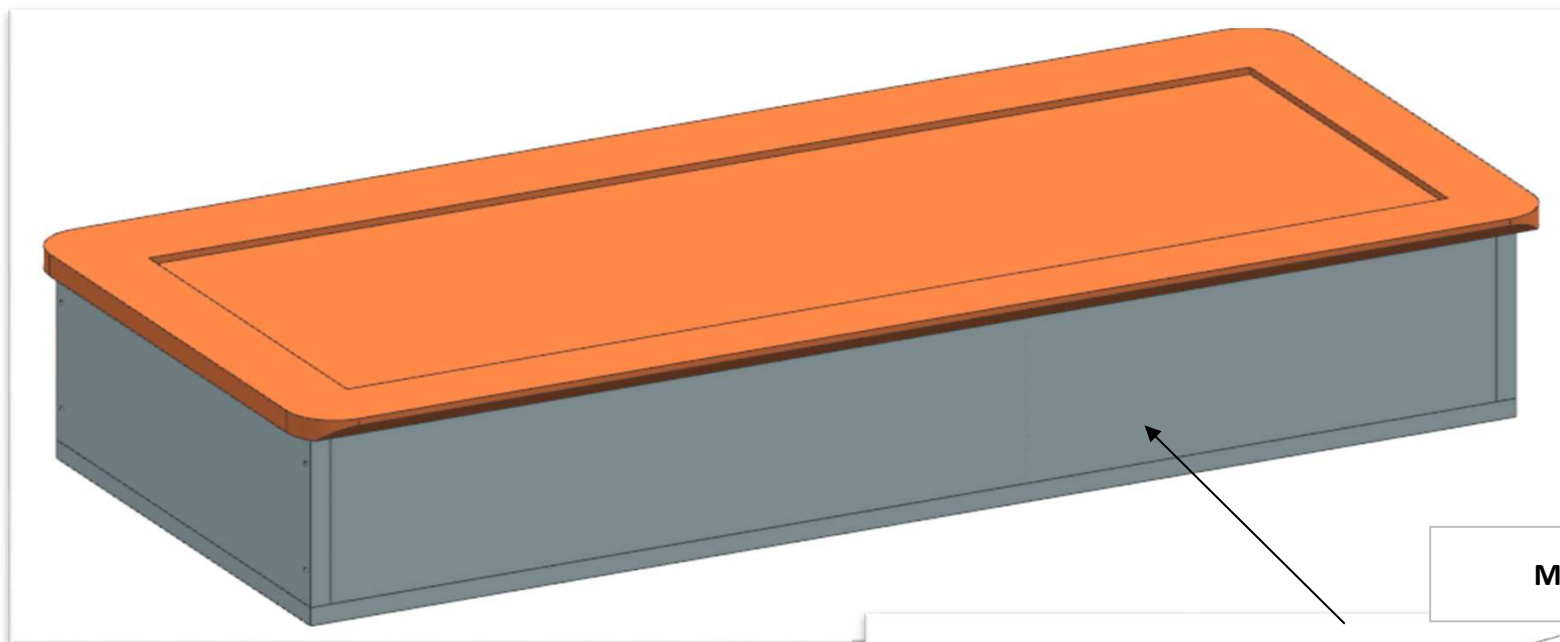

MONTARE CON

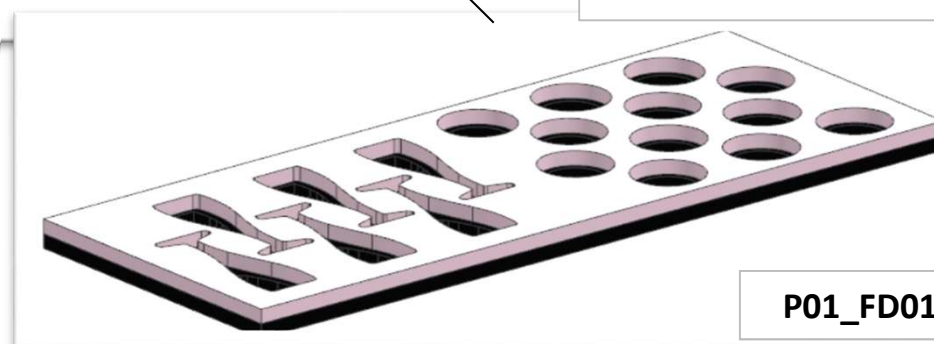

P01\_FD01

## **FERRAMENTA:**

- N° 3 - CERNIERA PIANA foro 40 frenate
- N° 3 - Basette H6
- N° 1 - BRACCETTO A SCATTO CEAM 602 DX
- N° 1 - BRACCETTO A SCATTO CEAM 602 SX

# AZ53F

DA MAT. 221 REV. 26-06-2024

LOCALE	CODICE	DESCRIZIONE COMPONENTE	FINITURA	Q.TA	OPERATORE
FRONTE MARCIA	AZ53F-FC01	CONNTENITORE PORTA BICCHIERI ANTIRIFLESSO	LAMINATO NADIR	1	Damiano

1 - L 982 x 404 x H.163

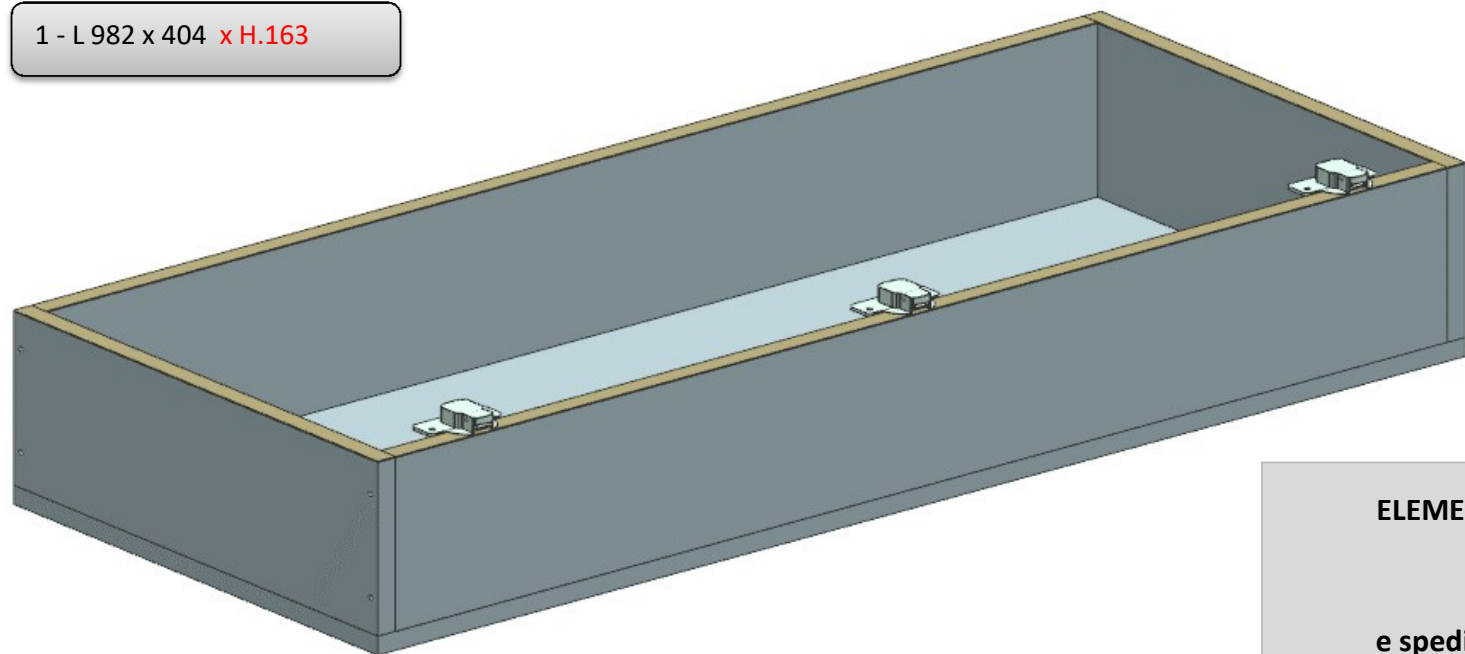

200  
ABBASSATO

ELEMENTO DA MONTARE con:  
L01\_FC01  
P01\_FD01  
e spedire con un unico imballo

## FERRAMENTA:

- N° 3 - CERNIERA PIANA foro 40 frenate
- N° 3 - BASETTE H6
- N° 1 - BRACCETTO A SCATTO CEAM 602 DX
- N° 1 - BRACCETTO A SCATTO CEAM 602 SX

L01\_FC01

P01\_FD01

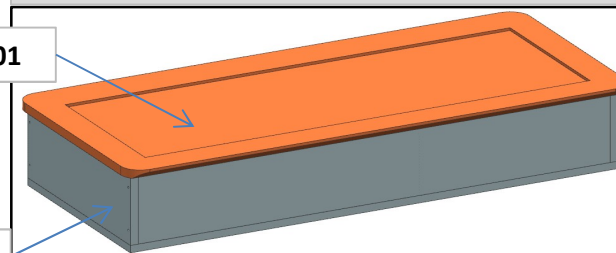

# AZ53F

DA MAT. 203 REV. 26-06-2024

LOCALE	CODICE	DESCRIZIONE COMPONENTE	FINITURA	Q.TA	OPERATORE
FRONTE MARCIA	AZ53F-L01_FC01	CONNTENITORE PORTA BICCHIERI ANTIRIFLESSO	LACCATO BRONZO	1	Damiano

1 - L.. 1016 x H 455 x sp 20

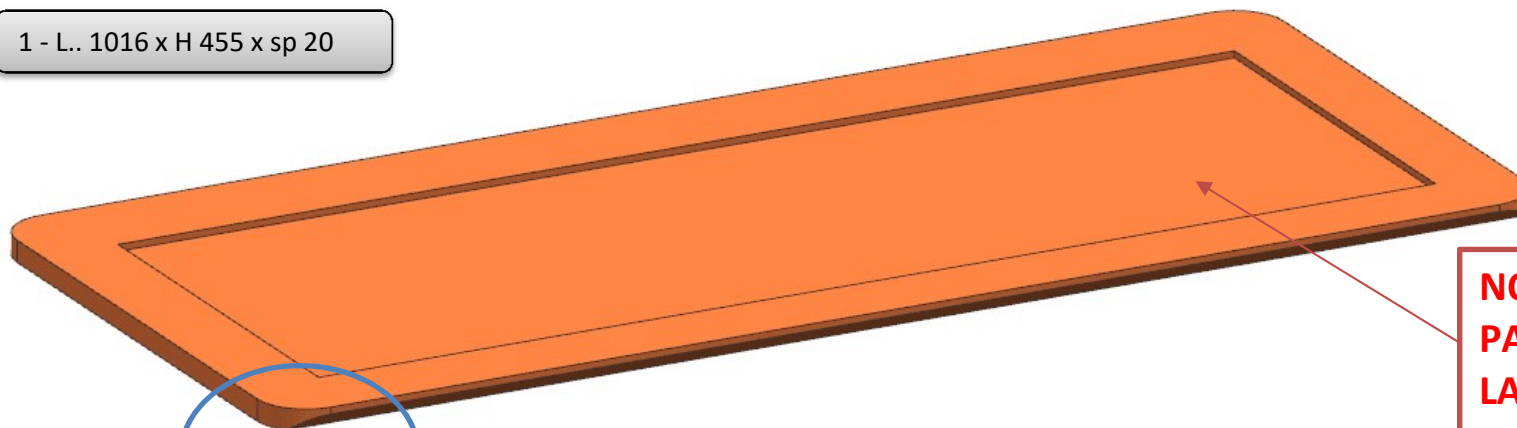

**NON METTERE  
PANNELLINO  
LACCATO BRONZO**

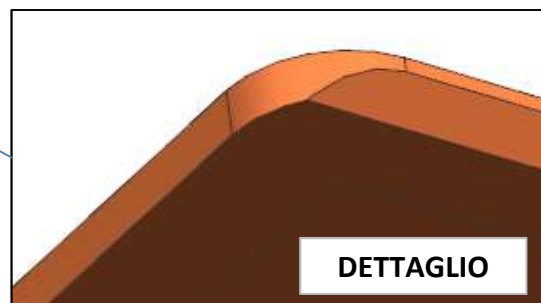
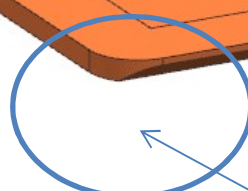

ELEMENTO DA MONTARE con:  
**FC01**  
**P01-FD01**  
e spedire con un unico imballo

**100**  
MODIFICATO IN PEZZO UNICO E DIVENTATO  
LACCATO BRONZO

P01\_FD01

FC01

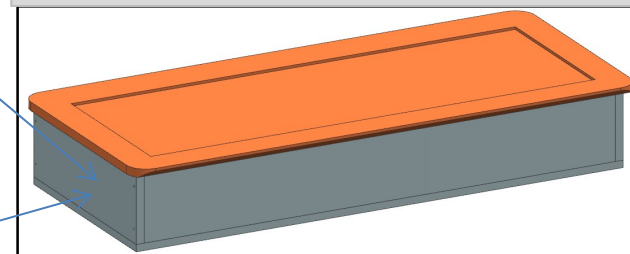

# AZ53F

REV. 26-06-2024

LOCALE	CODICE	DESCRIZIONE COMPONENTE	FINITURA	Q.TA	OPERATORE
FRONTE MARCIA	AZ53F-P01_FD01	PORTA BICCHIERI	FAGGIO\ GOMMA	2	Damiano

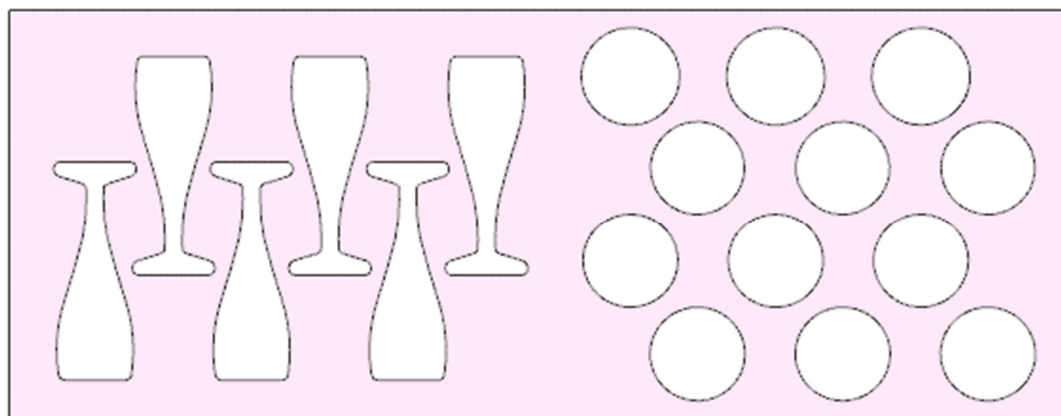

1 - 2 - L.950 x H.372 x sp 19

1

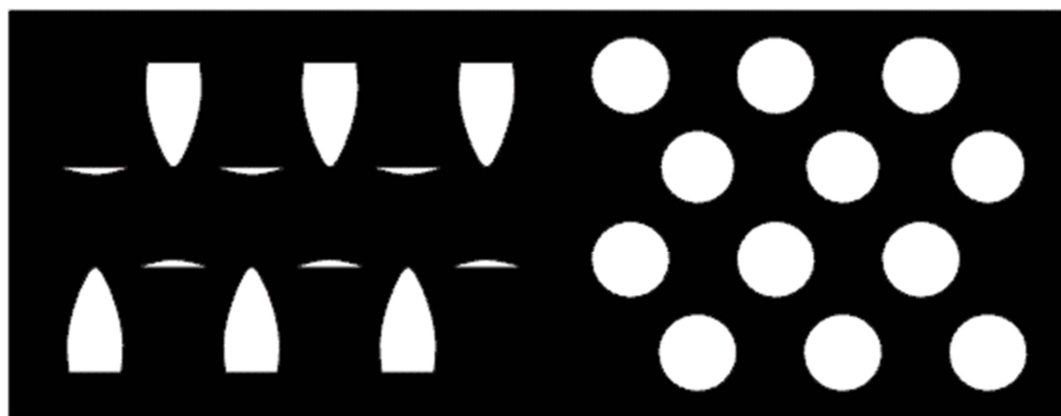

2

ELEMENTO DA MONTARE con:  
**FC01**  
**L01\_FC01**  
 e spedire con un unico imballo

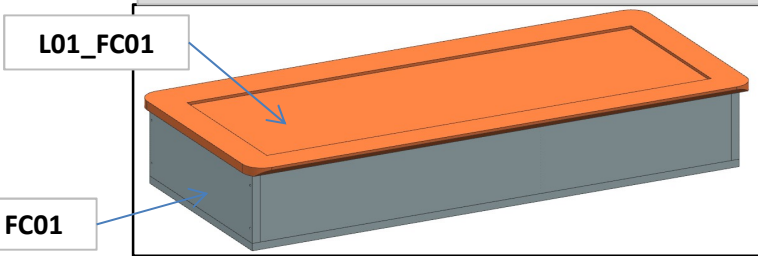

# AZ53F

DA MAT. 214 REV. 26-06-2024

LOCALE	CODICE	DESCRIZIONE COMPONENTE	FINITURA	Q.TA	OPERATORE
FRONTE MARCIA	AZ53F-I01_FE01	RIVESTIMENTO DX PRUA	OKOUME' GREZZO	1	Dante

1- L..1223 x H.784 x 54

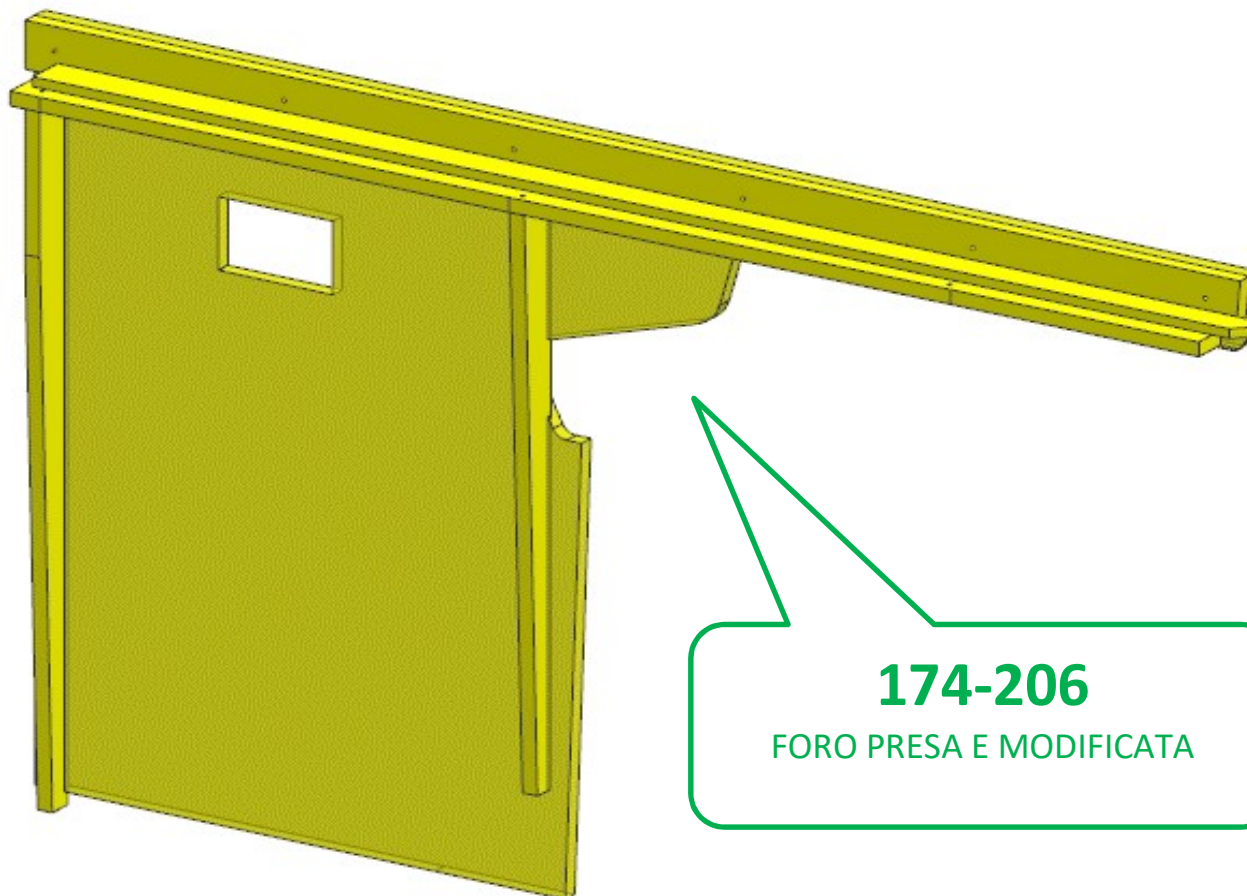

**174-206**

FORO PRESA E MODIFICATA

# AZ53F

DA MAT. 201 REV. 26-06-2024

LOCALE	CODICE	DESCRIZIONE COMPONENTE	FINITURA	Q.TA	OPERATORE
FRONTE MARCIA	AZ53F-MF_FF01	PEDANA GUIDA			Damiano

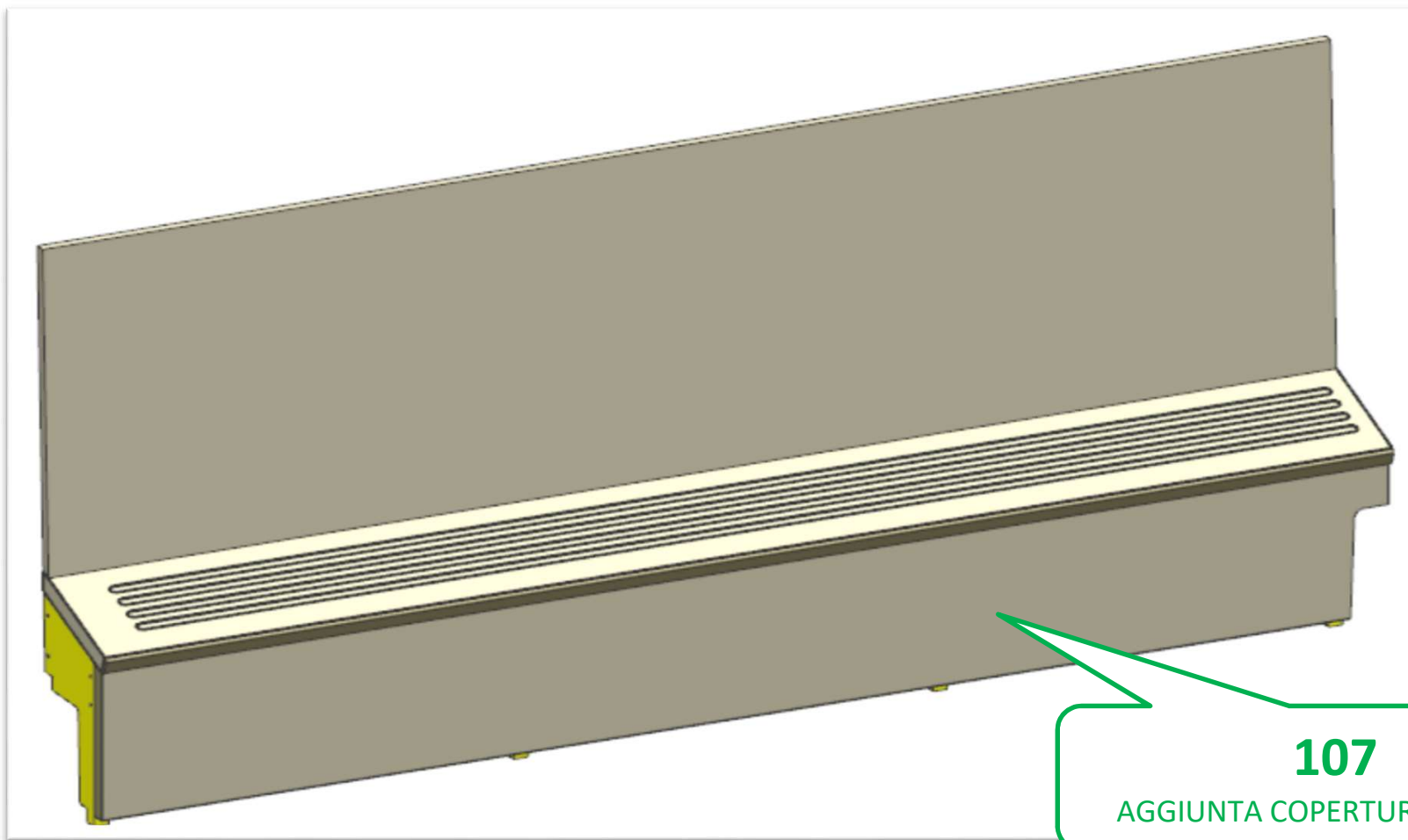

**107**

AGGIUNTA COPERTURA PEDANA

# AZ53F

DA MAT. 201 REV. 26-06-2024

LOCALE	CODICE	DESCRIZIONE COMPONENTE	FINITURA	Q.TA	OPERATORE
FRONTE MARCIA	AZ53F-FF01	PEDANA GUIDA	OKOUME GREZZO	1	Damiano

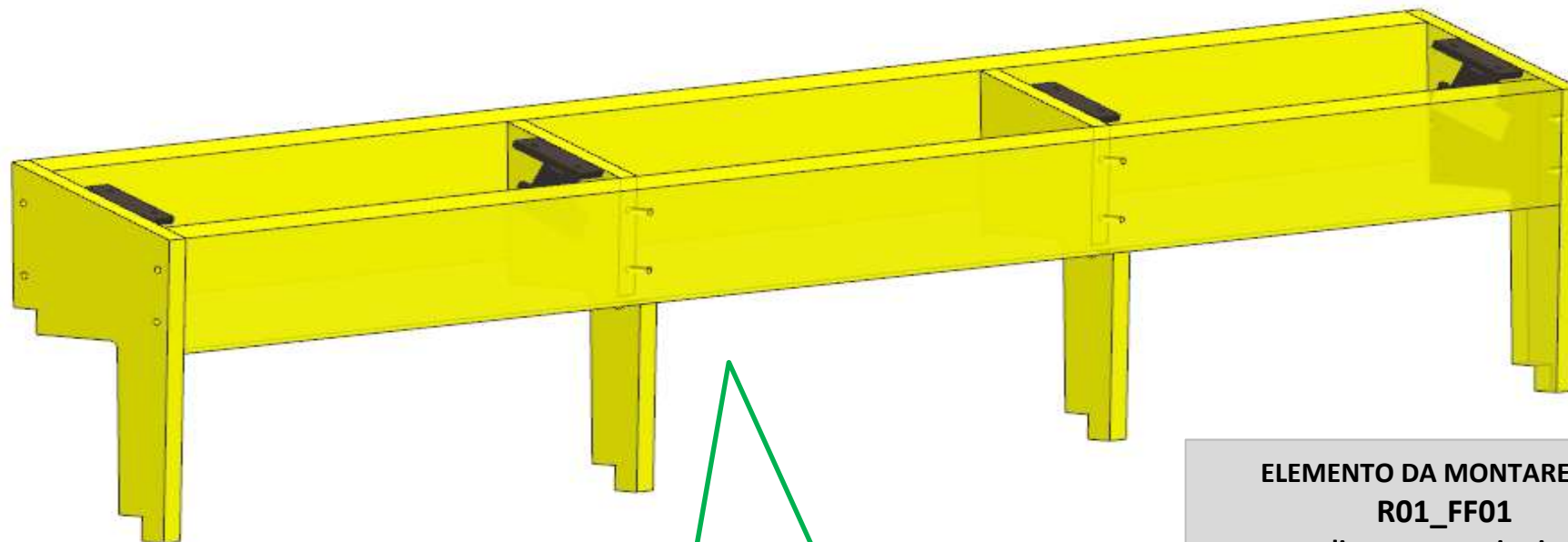

**107**  
AGGIUNTA STRUTTURA PER  
COPERTURA

ELEMENTO DA MONTARE con:  
**R01\_FF01**  
e spedire con un unico imballo

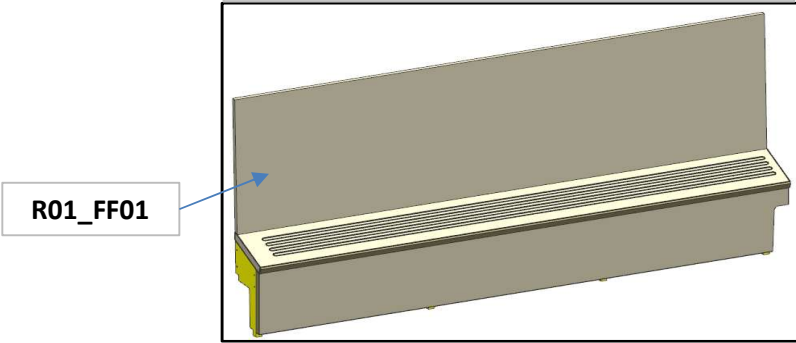

# AZ53F

DA MAT. 214 REV. 26-06-2024

LOCALE	CODICE	DESCRIZIONE COMPONENTE	FINITURA	Q.TA	OPERATORE
FRONTE MARCIA	AZ53F-R01_FF01	PEDANA GUIDA	LASTRA CHIARA	3	Damiano

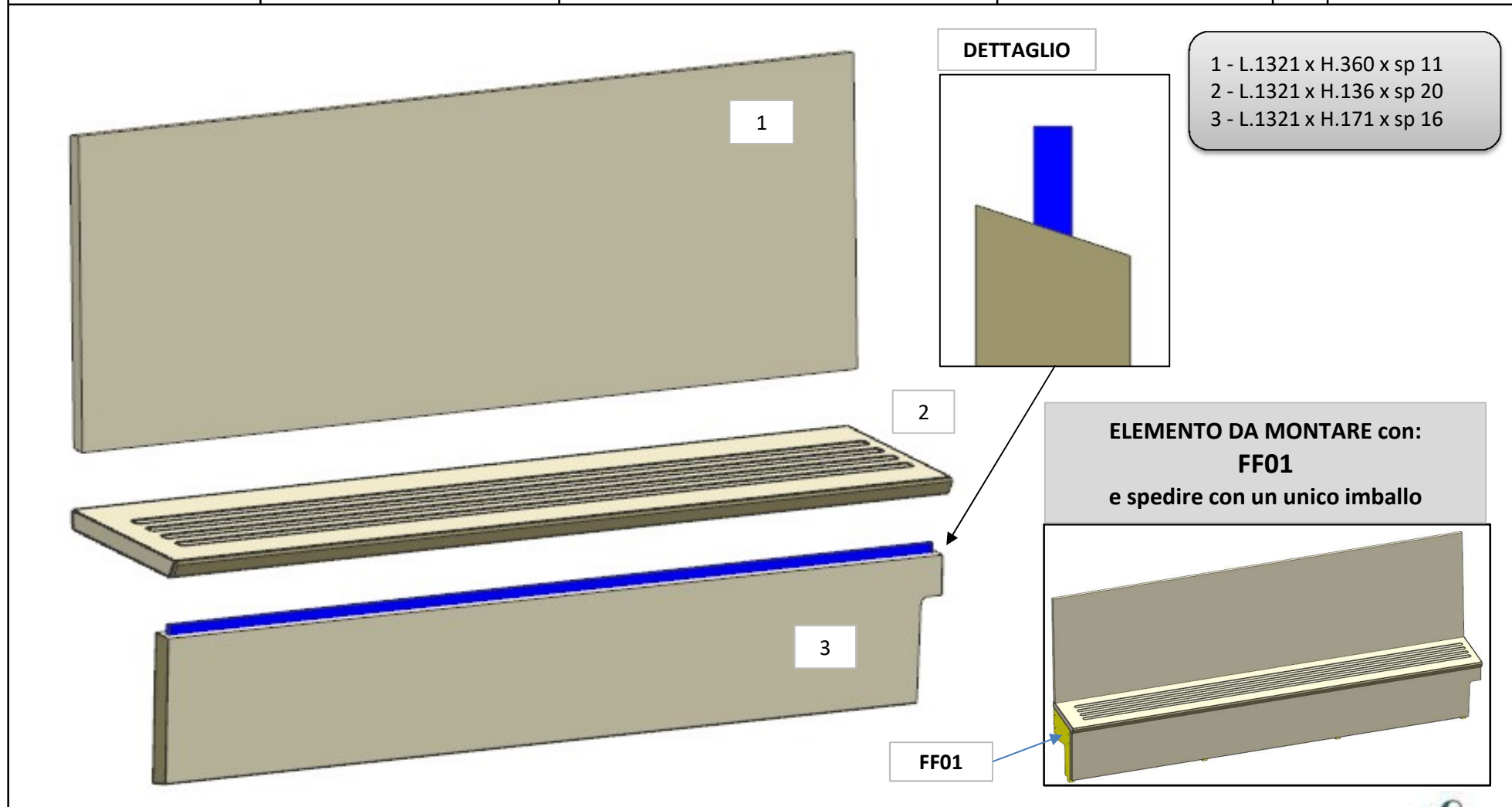

# AZ53F

DA MAT. 201 REV. 26-06-2024

LOCALE	CODICE	DESCRIZIONE COMPONENTE	FINITURA	Q.TA	OPERATORE
FRONTE MARCIA	AZ53F-MF_FG01\FG02	MOBILE SEDILE GUIDA			Damiano

- AGGIUNTO PZ. n°5 e 6
- CREATO APERTURA TOP PZ. n°1
- TOLTO DIVISIONE INTERNA PZ. n°2
- MODIFICATA STRUTTURA GREZZA

#### FERRAMENTA:

- N° 2 - GUIDA DA 350
- N° 2 - FLUSH LOCK
- N° 10 - KEKU FRONTALE
- N° 4 - SOUTHCO
- N° 14 - BUSSOLA ZAMA 6MA
- N° 8 - VITI 6MA

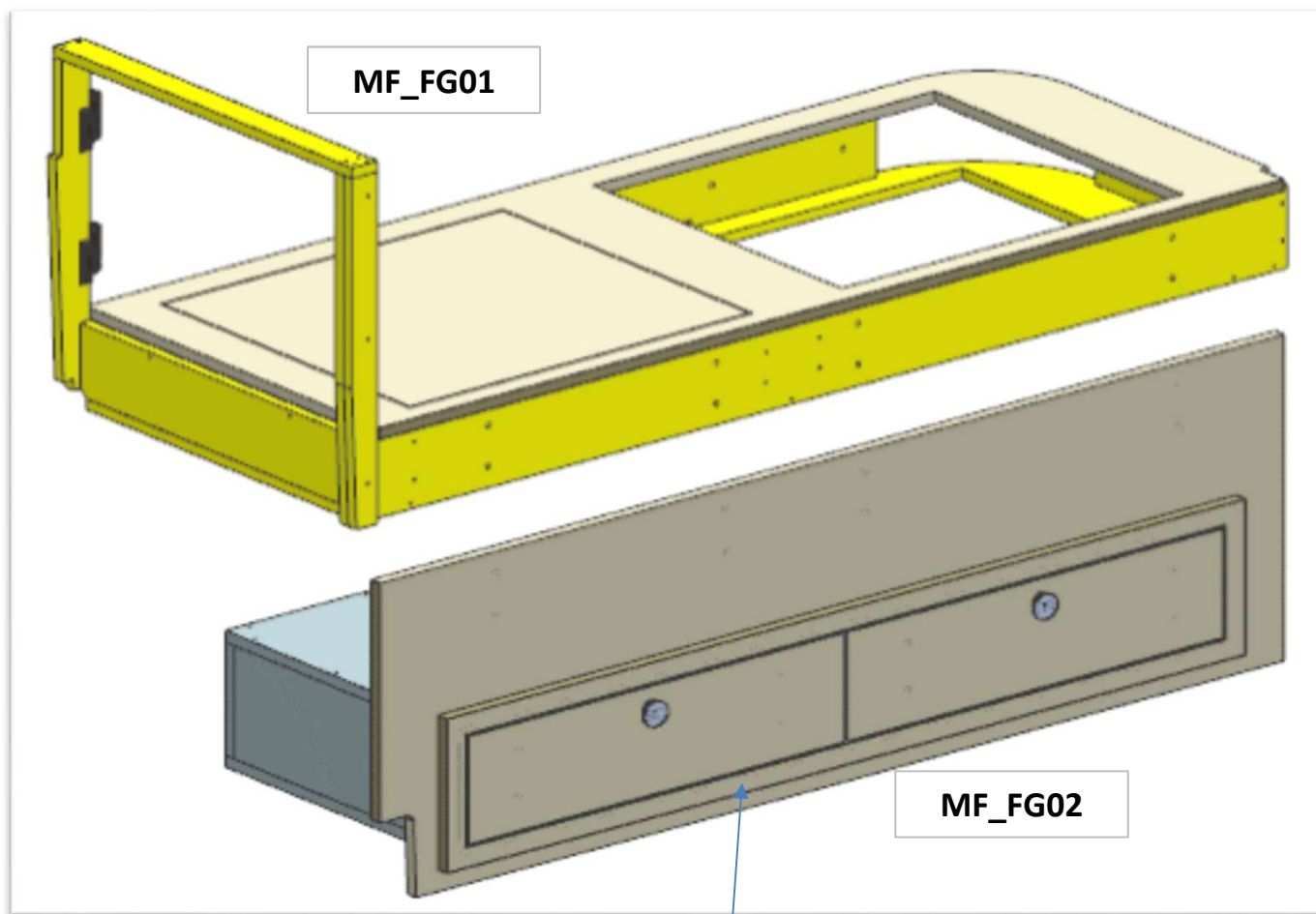

cornice avvitata dietro il pannello

# AZ53F

DA MAT. 221 REV. 26-06-2024

LOCALE	CODICE	DESCRIZIONE COMPONENTE	FINITURA	Q.TA	OPERATORE
FRONTE MARCIA	AZ53F-FG01	MOBILE SEDILE GUIDA	OKOUME' GREZZO	2	Damiano

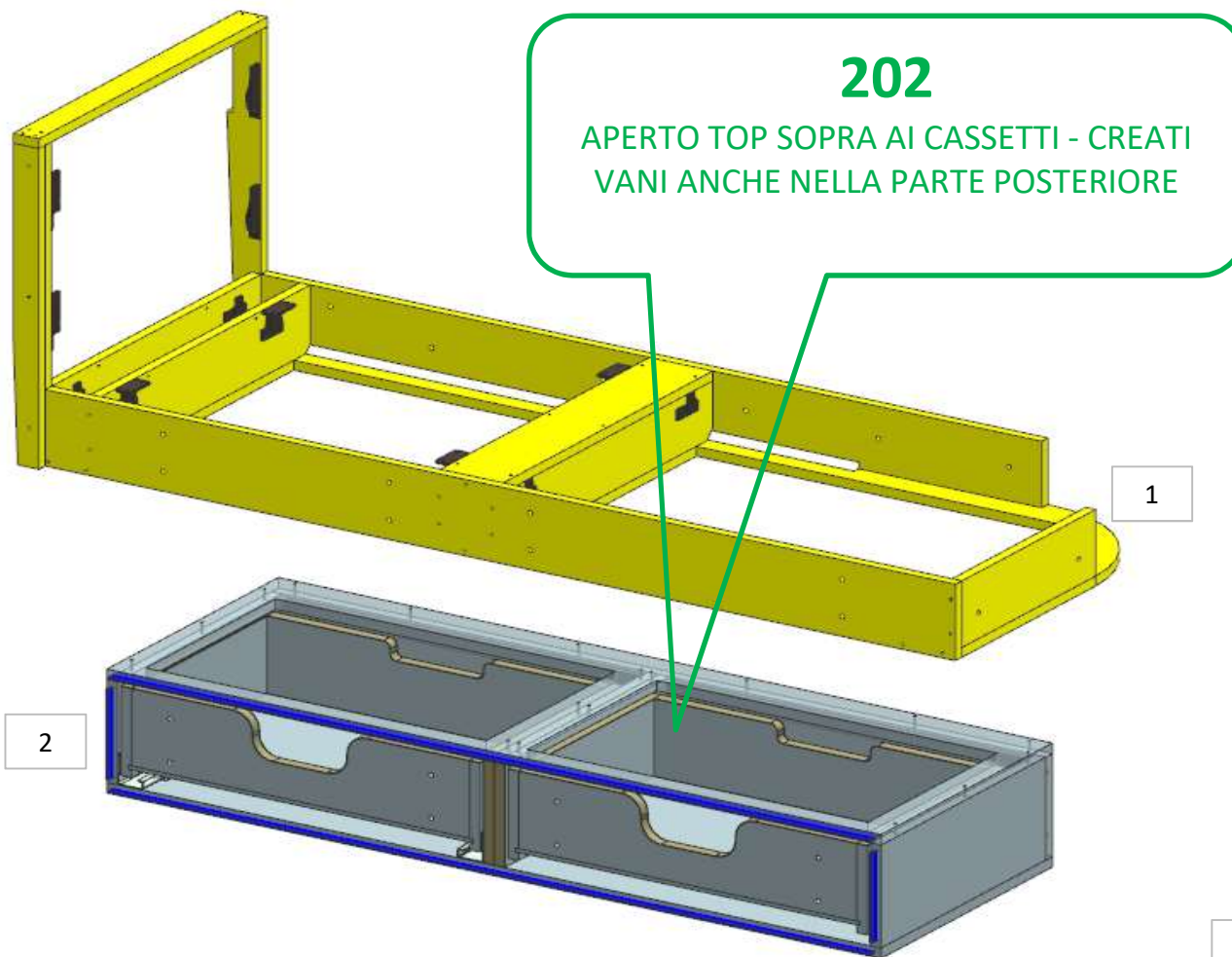

#### FERRAMENTA:

- N° 2 - GUIDA DA 350
- N° 2 - FLUSH LOCK
- N° 10 - KEKU FRONTALE
- N° 4 - SOUTHCO
- N° 14 - BUSSOLA ZAMA 6MA
- N° 8 - VITI 6MA

#### ELEMENTO DA MONTARE con:

**MF\_FG01**

**MF\_FG02**

e spedire con un unico imballo

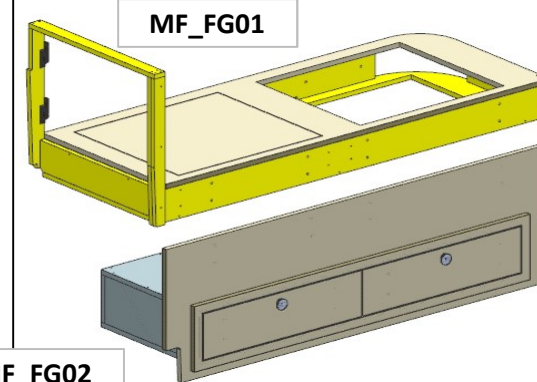

# AZ53F

DA MAT. 221 REV. 26-06-2024

LOCALE	CODICE	DESCRIZIONE COMPONENTE	FINITURA	Q.TA	OPERATORE
FRONTE MARCIA	AZ53F-R01_FG01	MOBILE SEDILE GUIDA	LASTRA CHIARA	6	Damiano

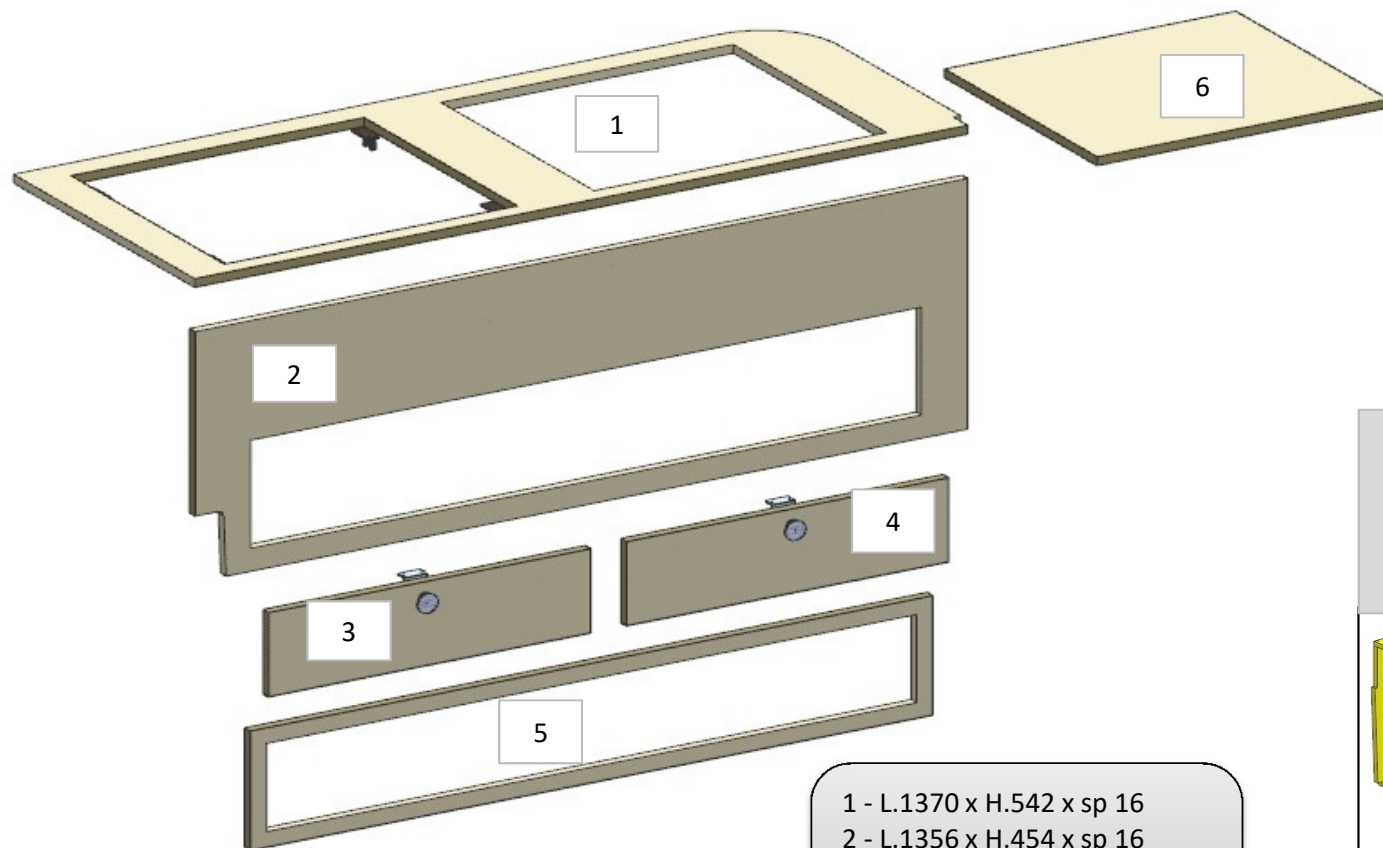

- 1 - L.1370 x H.542 x sp 16
- 2 - L.1356 x H.454 x sp 16
- 3 - 4 - L.566 x H.153 x sp 16
- 5 - L. 1198 x H.217 x sp 16
- 6 - L. 512 x H.457 x sp 16

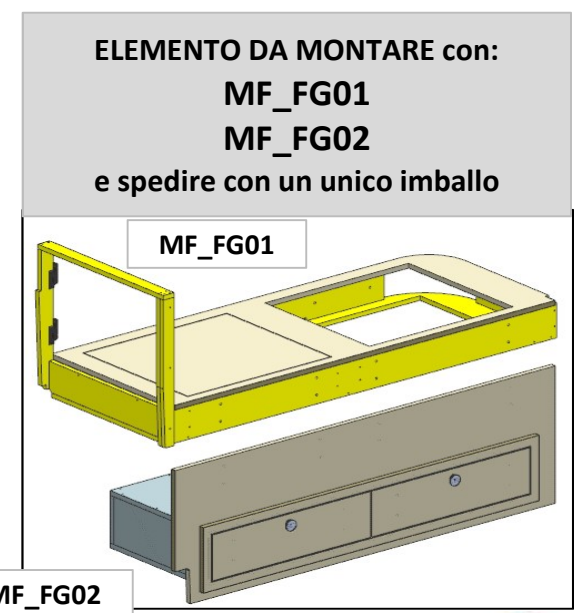

# AZ53F

REV. 26-06-2024

LOCALE	CODICE	DESCRIZIONE COMPONENTE	FINITURA	Q.TA	OPERATORE
FRONTE MARCIA	AZ53F-I01_FG01	MOBILE SEDILE GUIDA	OKOUME' GREZZO	3	Dante

- 1 - L 897 x H.434. x sp 30
- 2 - L 1358 x H 174 x 500
- 3 - L 1377x H 708 x 585

**DIVISO IN 3 PEZZI**

