

AZ53F

MODIFICATA CODIFICA DA MAT. 221

REV.26-06-2024

LOCALE	CODICE	DESCRIZIONE COMPONENTE	FINITURA	Q.TA	OPERATORE
CABINA ARMATORE	AZ53F-AAW01	MOBILE CONTENITORE MURATA DX	LAMINATO NADIR\ GREZZO	1	Damiano

I01_AAX01

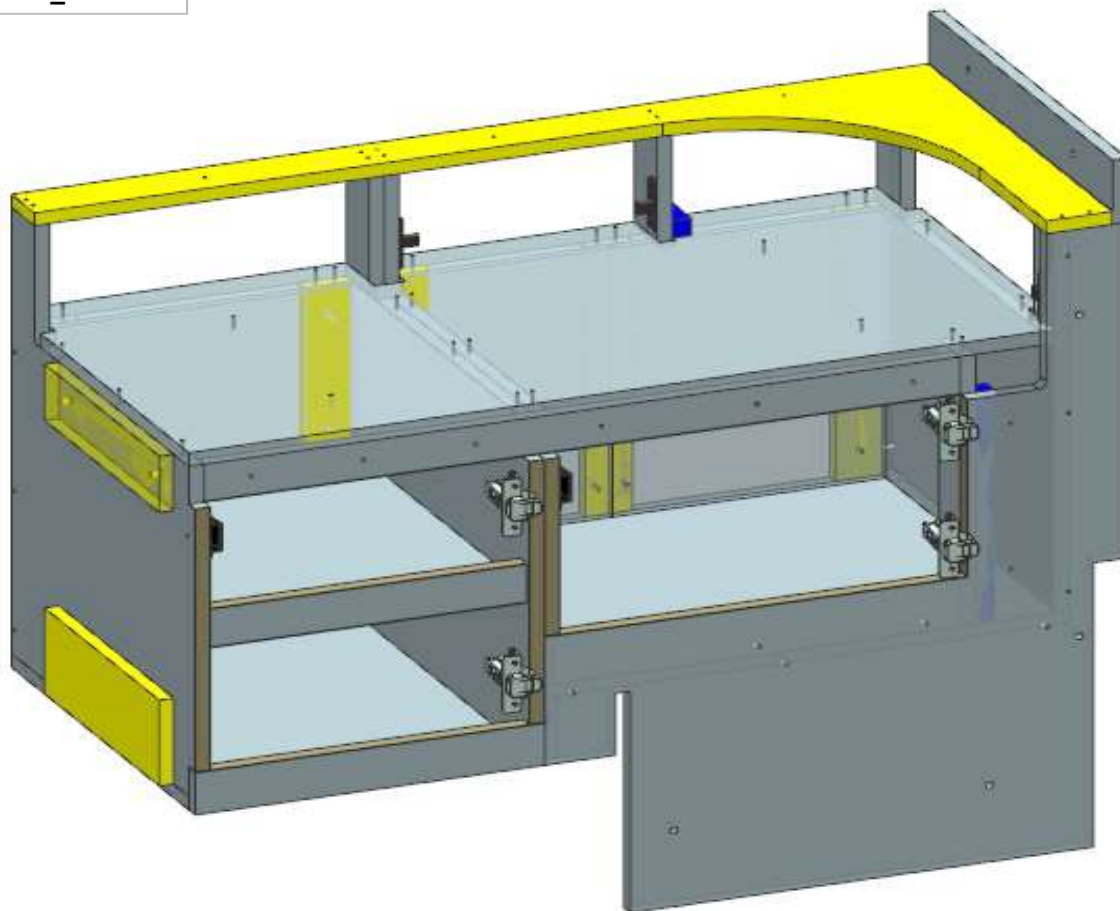

ELEMENTO DA MONTARE con:
R01_AAW01
L01_AAW01

L01_AAW01

R01_AAW01

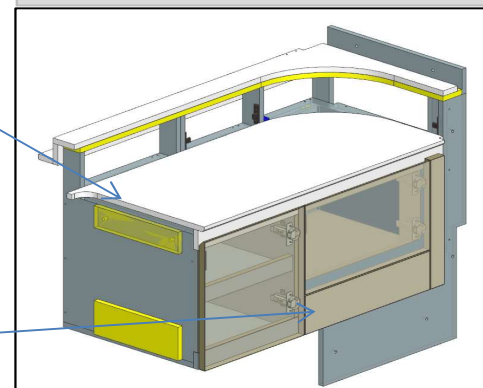

AZ53F

MODIFICATA CODIFICA DA MAT. 221

REV.26-06-2024

LOCALE	CODICE	DESCRIZIONE COMPONENTE	FINITURA	Q.TA	OPERATORE
CABINA ARMATORE	AZ53F-AAX01	MOBILE CONTENITORE MURATA DX	LAMINATO NADIR\ GREZZO	1	Damiano

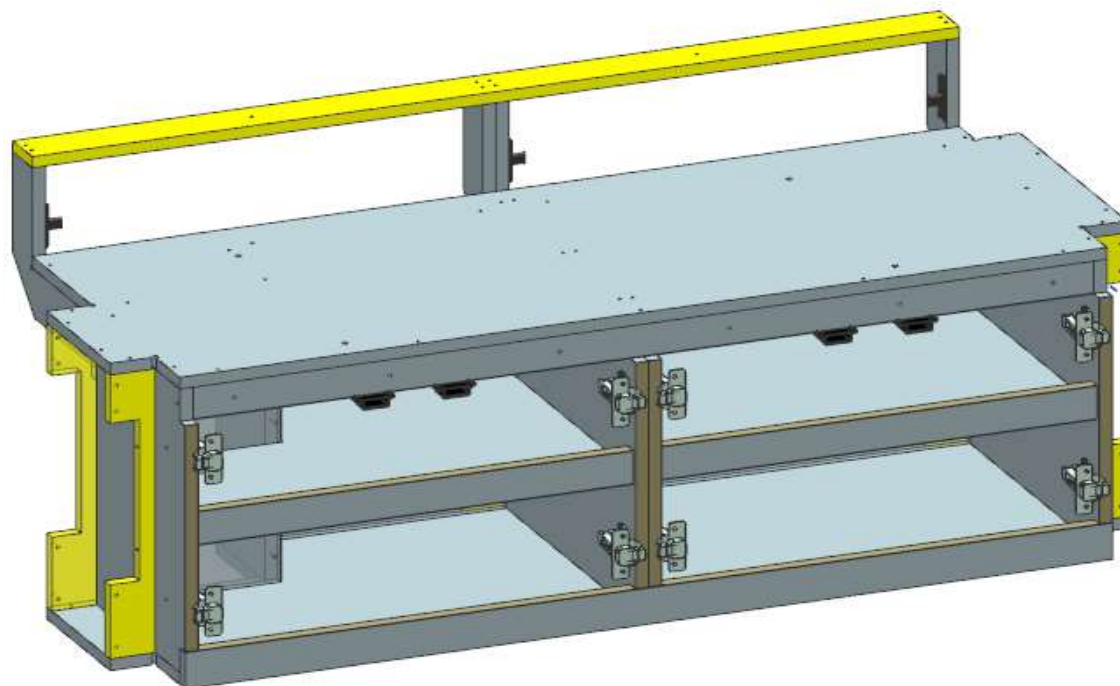

ELEMENTO DA MONTARE con:

R01_AAX01

L01_AAX01

L02_AAX01

I01_AAX01

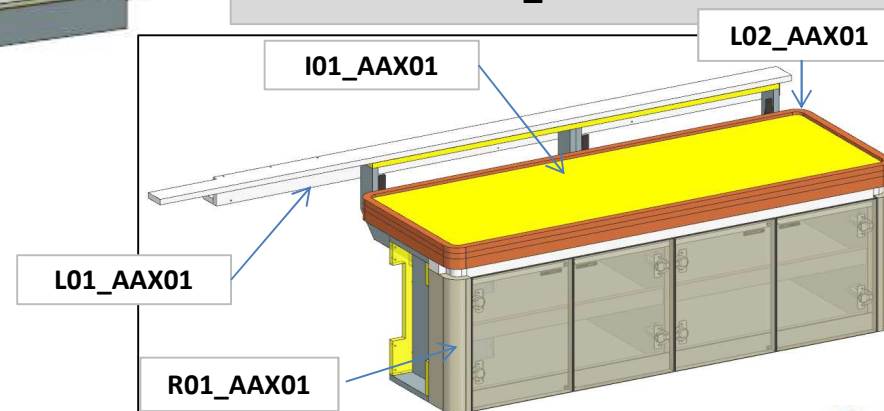

consonni&c

AZ53F

MODIFICATA CODIFICA DA MAT. 247

REV.26-06-2024

LOCALE	CODICE	DESCRIZIONE COMPONENTE	FINITURA	Q.TA	OPERATORE
CABINA ARMATORE	AZ53F-AAY01	MOBILE CONTENITORE MURATA DX	LAMINATO NADIR\ GREZZO	1	Damiano

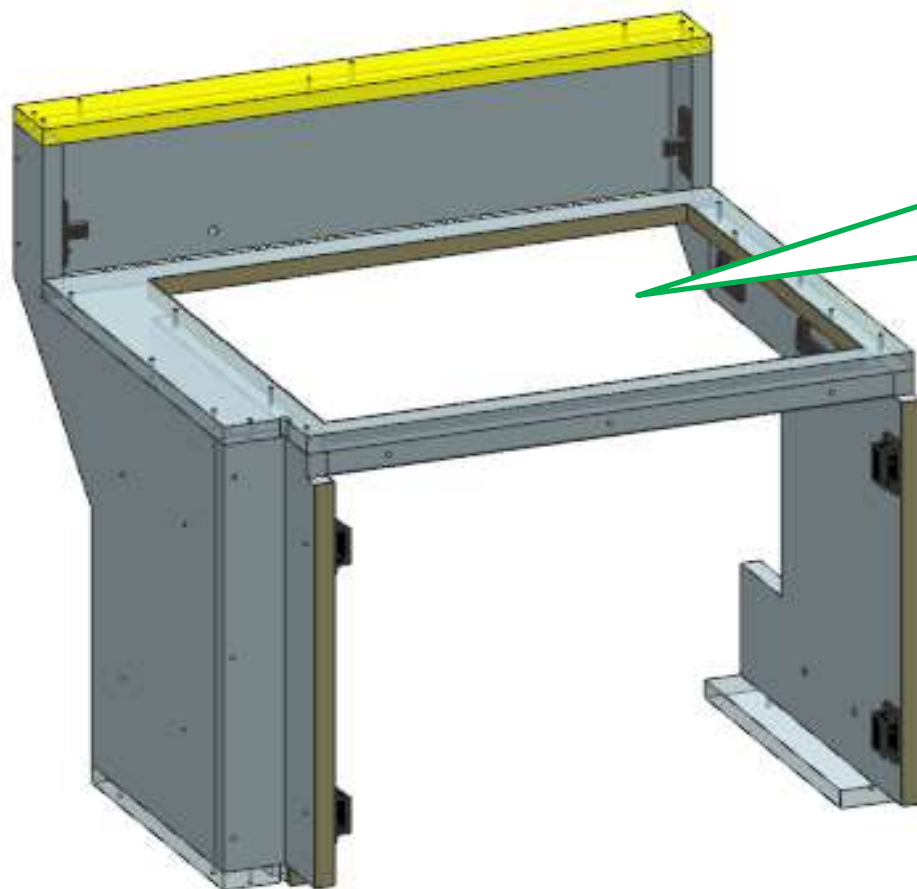

DB 160

METTERE SOUTCHO E
METTERE TAPPINI SUI
BUCHI

ELEMENTO DA MONTARE con:

R01_AAY01

L01_AAY01

L01_AAY01

R01_AAY01

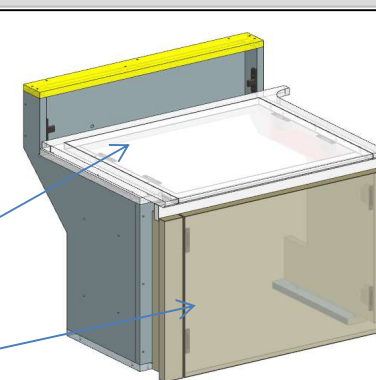

consonni&c

AZ53F

REV.26-06-2024

LOCALE	CODICE	DESCRIZIONE COMPONENTE	FINITURA	Q.TA	OPERATORE
CABINA ARMATORE	AZ53F-AB01	STRUTTURA RETRO COMODINO DX	OKOUME' GREZZO	1	Dante



FERRAMENTA:

N° 4 - KEKU A PETTINE

AZ53F

REV.26-06-2024

LOCALE	CODICE	DESCRIZIONE COMPONENTE	FINITURA	Q.TA	OPERATORE
CABINA ARMATORE	AZ53F-AC01	COMODINO DX	LAMINATO NADIR	2	Damiano

L: 164
pistone 45 lato sx.

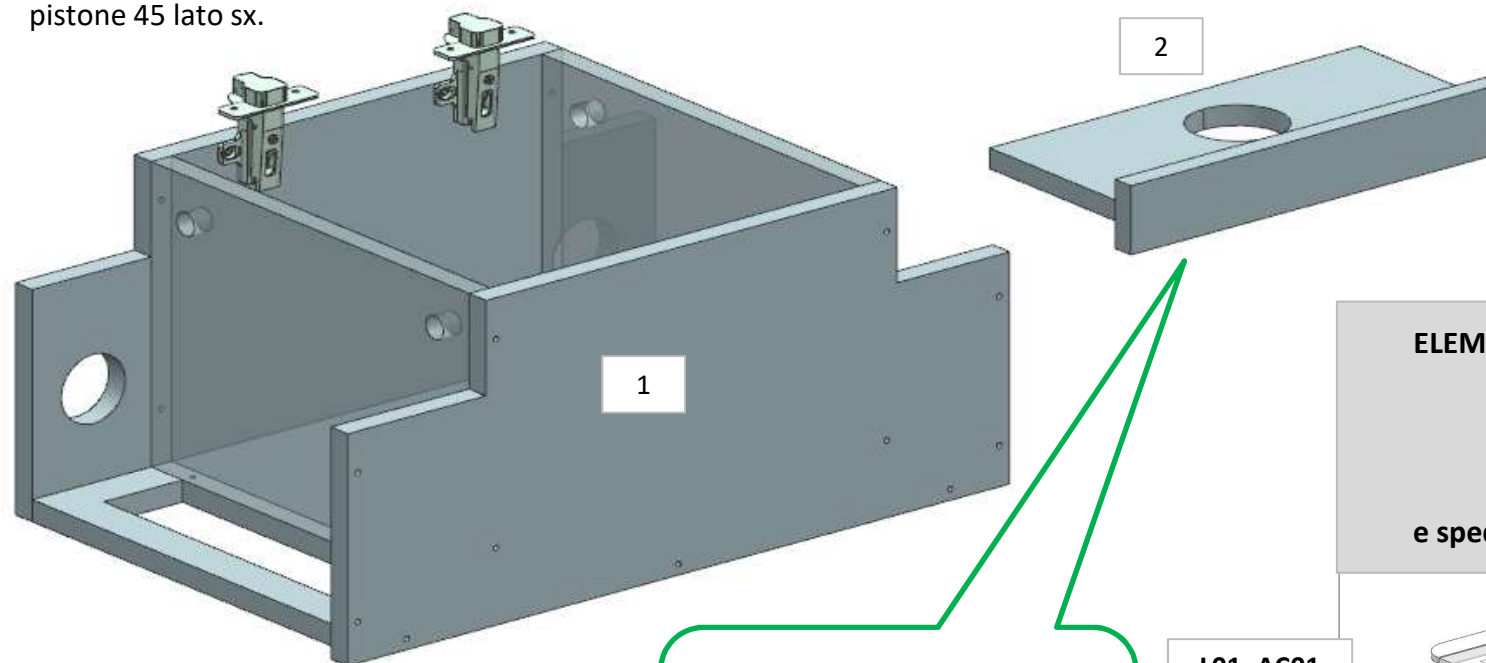

**MONTARE PISTONI
LIVENZA 164 - 45
NEWTON**

ELEMENTO DA MONTARE con:
R01_AC01
L01_AC01
I01_AC01
 e spedire con un unico imballo

85
 AGGIUNTA MENSOLA
 ALL'INTERNO DEL
 COMODINO

FERRAMENTA:
 N° 2 - CERNIERA PIANA
 N° 2 - BASETTE H6
 N° - PISTONI LIVENZA 164 45 NW

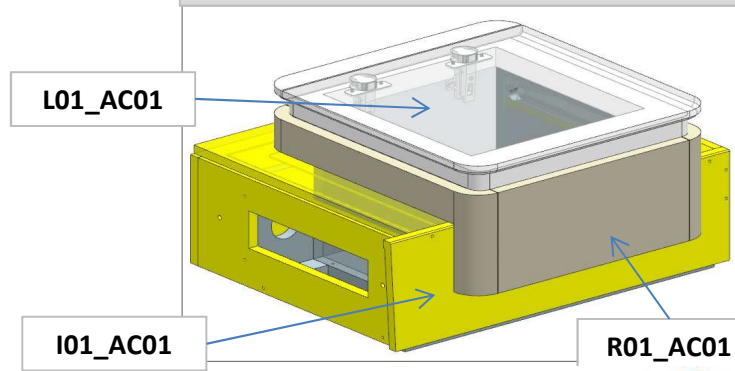

AZ53F

DA MAT. 201 REV.26-06-2024

LOCALE	CODICE	DESCRIZIONE COMPONENTE	FINITURA	Q.TA	OPERATORE
CABINA ARMATORE	AZ53F-AD01	STRUTTURA RETRO LETTO	OKOUME' GREZZO	1	Dante

33
VERIFICARE
ACCOPPIAMENTO CON
IMBOTTITO

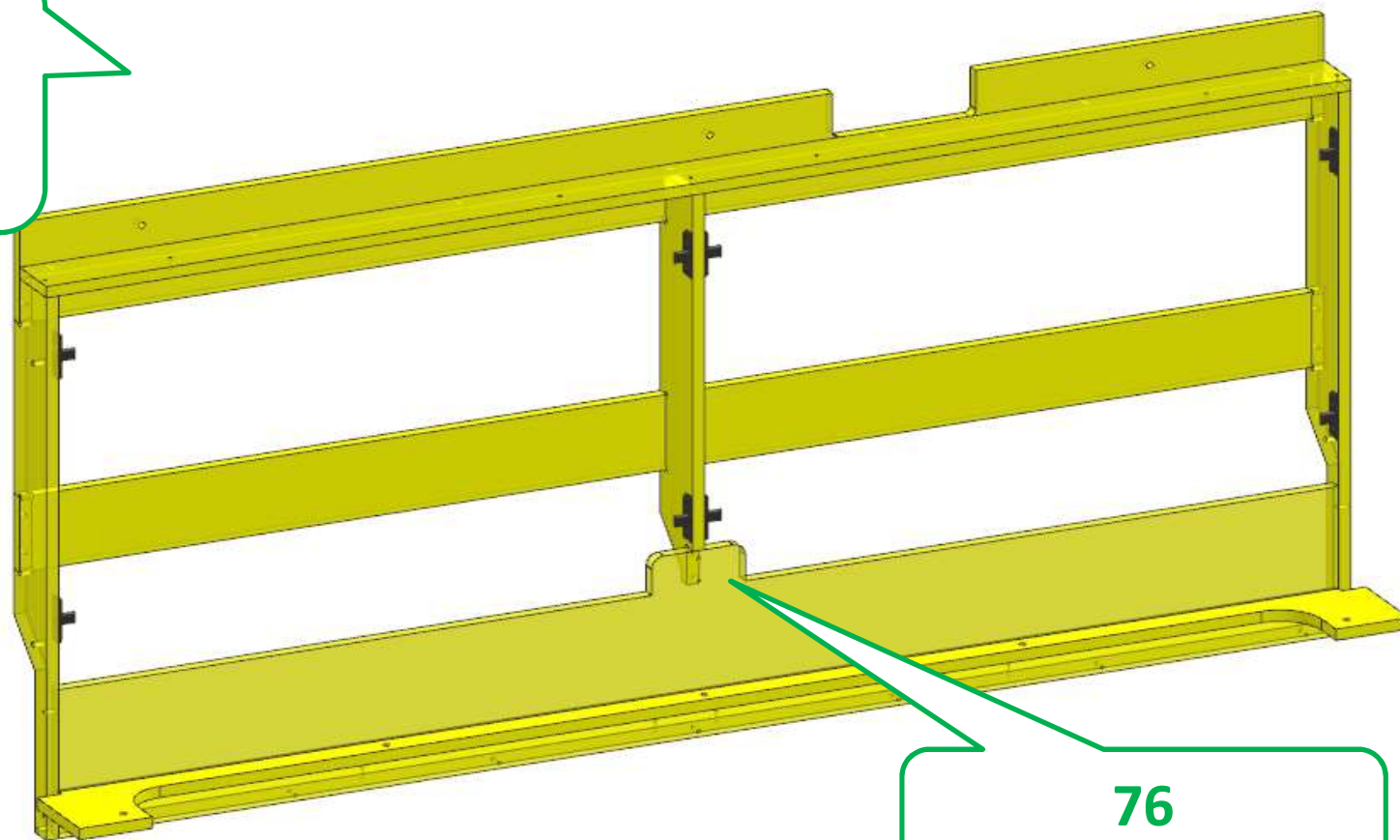

FERRAMENTA:
N° 8 - KEKU A PETTINE

76
MODIFICATA STRUTTURA

AZ53F

REV.26-06-2024

LOCALE	CODICE	DESCRIZIONE COMPONENTE	FINITURA	Q.TA	OPERATORE
CABINA ARMATORE	AZ53F-AE01	STRUTTURA RETRO COMODINO SX	OKOUME' GREZZO	1	Dante

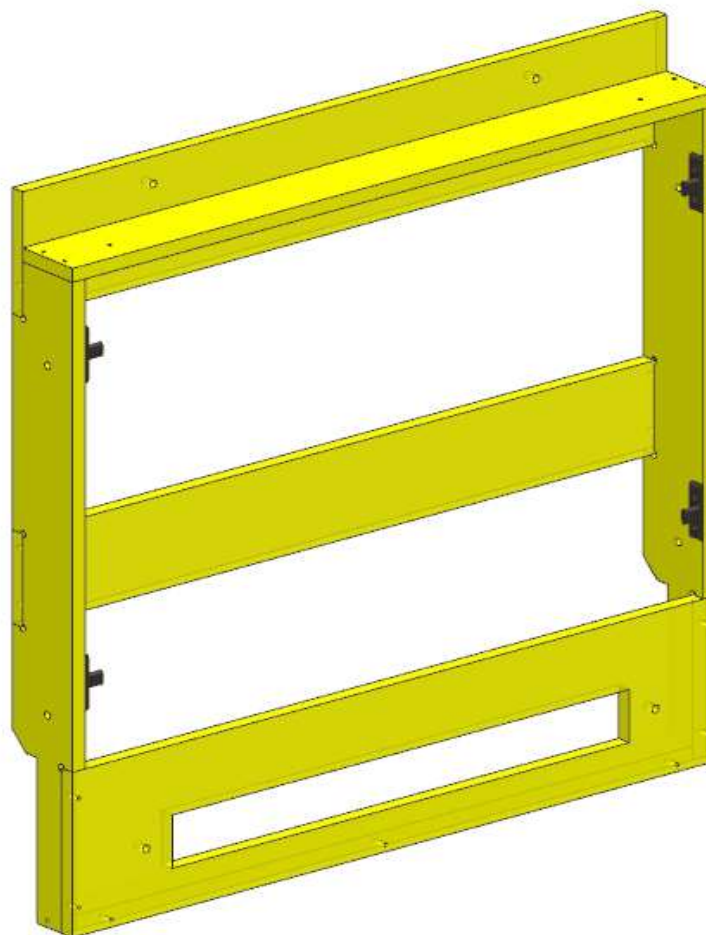

FERRAMENTA:

N° 4 - KEKU A PETTINE

AZ53F

REV.26-06-2024

LOCALE	CODICE	DESCRIZIONE COMPONENTE	FINITURA	Q.TA	OPERATORE
CABINA ARMATORE	AZ53F-AF01	COMODINO SX	LAMINATO NADIR	2	Damiano

**MONTARE PISTONI
LIVENZA 164 - 45
NEWTON**

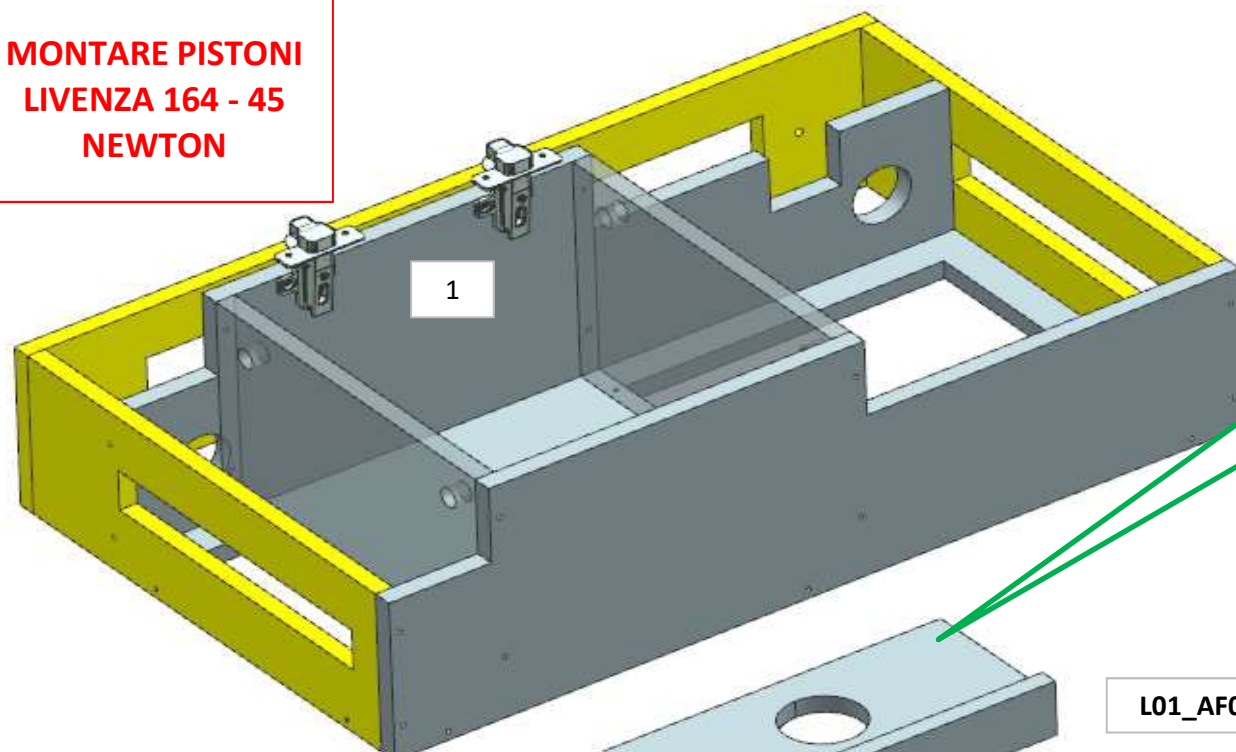

85

AGGIUNTA MENSOLA
ALL'INTERNO DEL
COMODINO

ELEMENTO DA MONTARE con:
R01_AF01
L01_AF01
I01_AF01
e spedire con un unico imballo

FERRAMENTA:

N° 2 - CERNIERA PIANA
N° 2 - BASETTE H6
N° - PISTONI LIVENZA 164 - 45 NW

L01_AF01

R01_AF01

I01_AF01

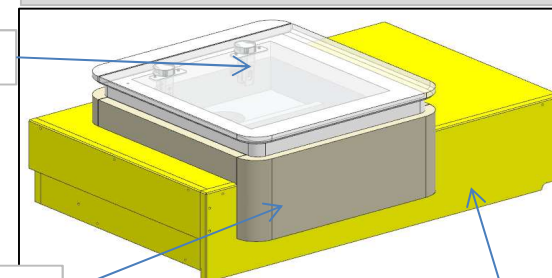

consonni&c

AZ53F

REV.26-06-2024

LOCALE	CODICE	DESCRIZIONE COMPONENTE	FINITURA	Q.TA	OPERATORE
CABINA ARMATORE	AZ53F-AG01	STRUTTURA ANGOLO DIVANO	OKOUME' GREZZO	1	Dante

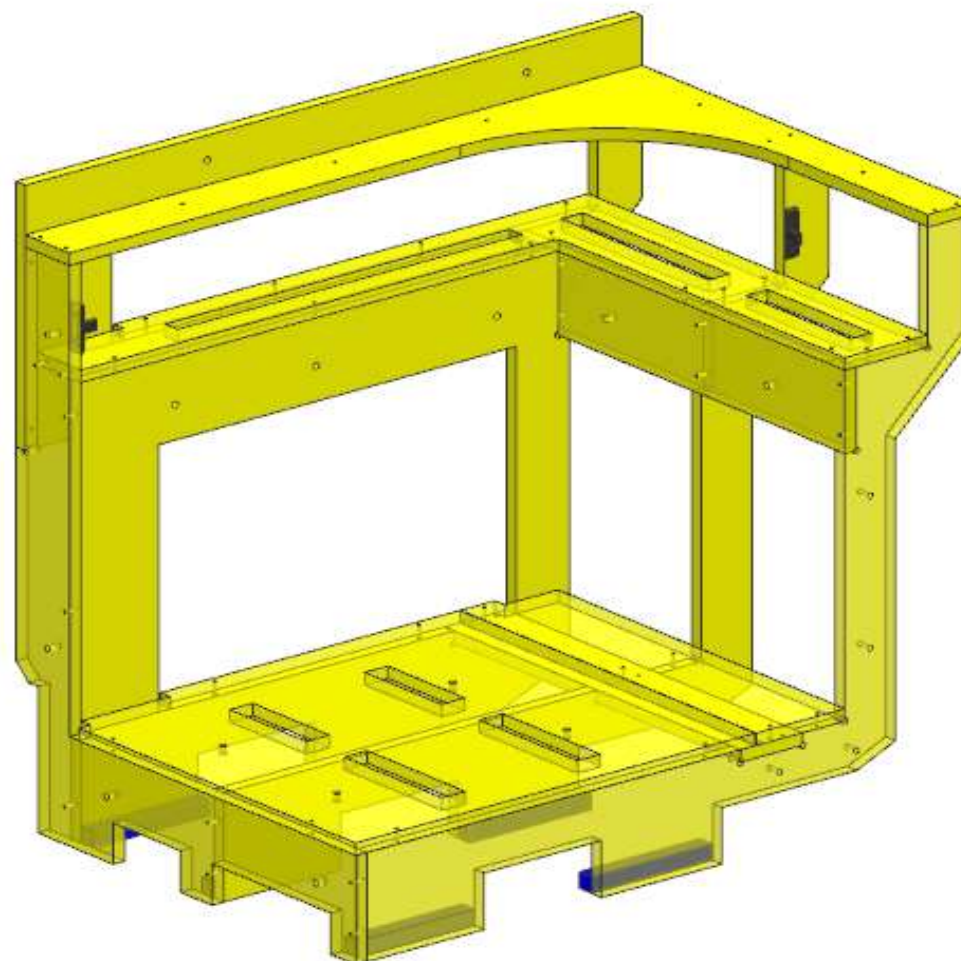

FERRAMENTA:

N° 2 - KEKU A PETTINE

AZ53F

DA MAT. 201 REV.26-06-2024

LOCALE	CODICE	DESCRIZIONE COMPONENTE	FINITURA	Q.TA	OPERATORE
CABINA ARMATORE	AZ53F-AH01	STRUTTURA CORTA DIVANO SX	OKOUME' GREZZO	1	Dante

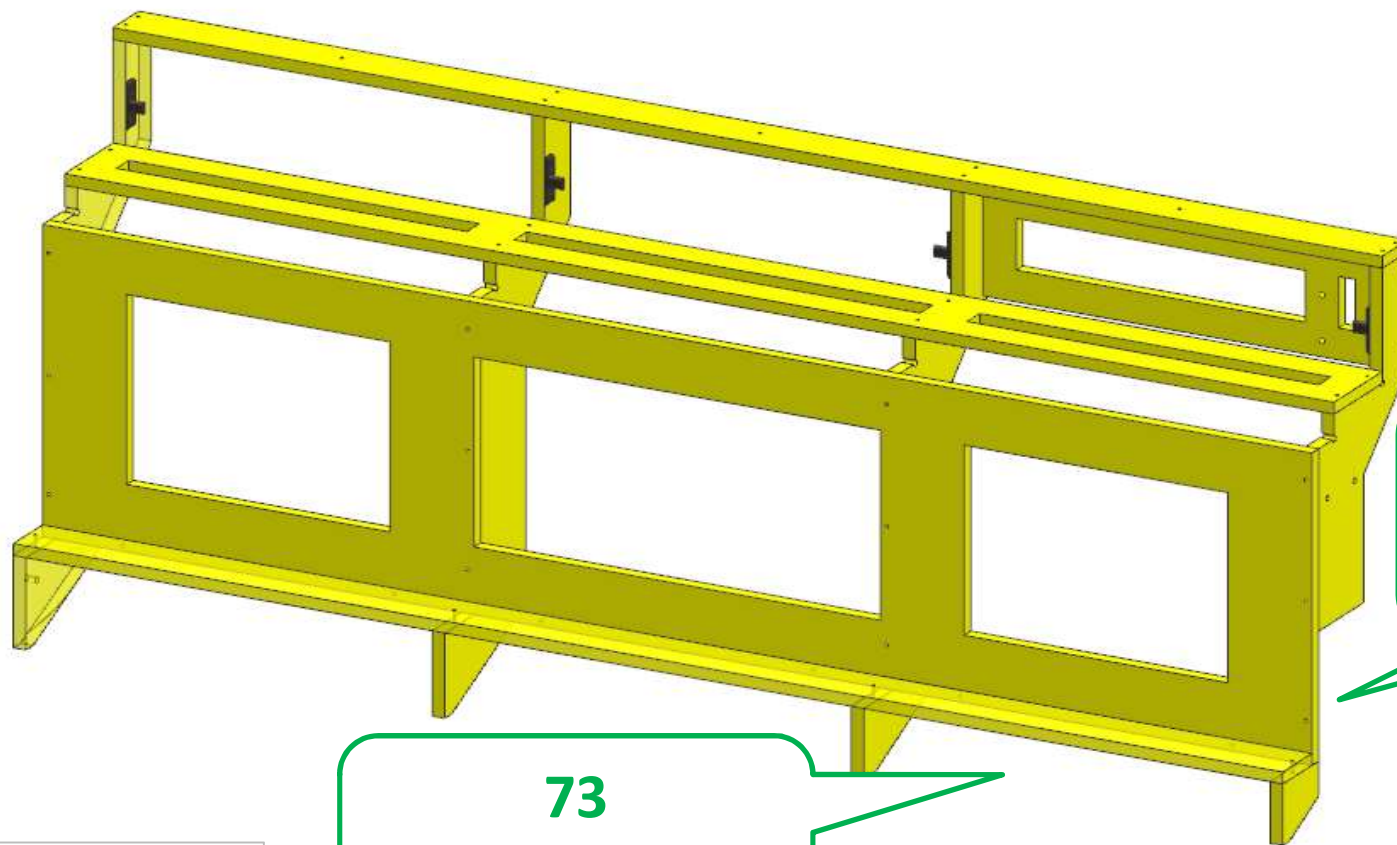

49

CREATO SCASSO PER
PASSAGGIO CAVI

73

ELIMINATO PANNELLO
FRONTALE

FERRAMENTA:

N° 2 - KEKU A PETTINE

AZ53F

DA MAT. 227 REV.26-06-2024

LOCALE	CODICE	DESCRIZIONE COMPONENTE	FINITURA	Q.TA	OPERATORE
CABINA ARMATORE	AZ53F-AI01	RETE LETTO	LACCATO BIANCO GOFFRATONE	5	Dante

DB-152
VERIFICARE PRESENZA
RINFORZI SOTTO
ALL'ANTA

**PZ N° 5 NON AVVITARE
AL PZ. N 1**

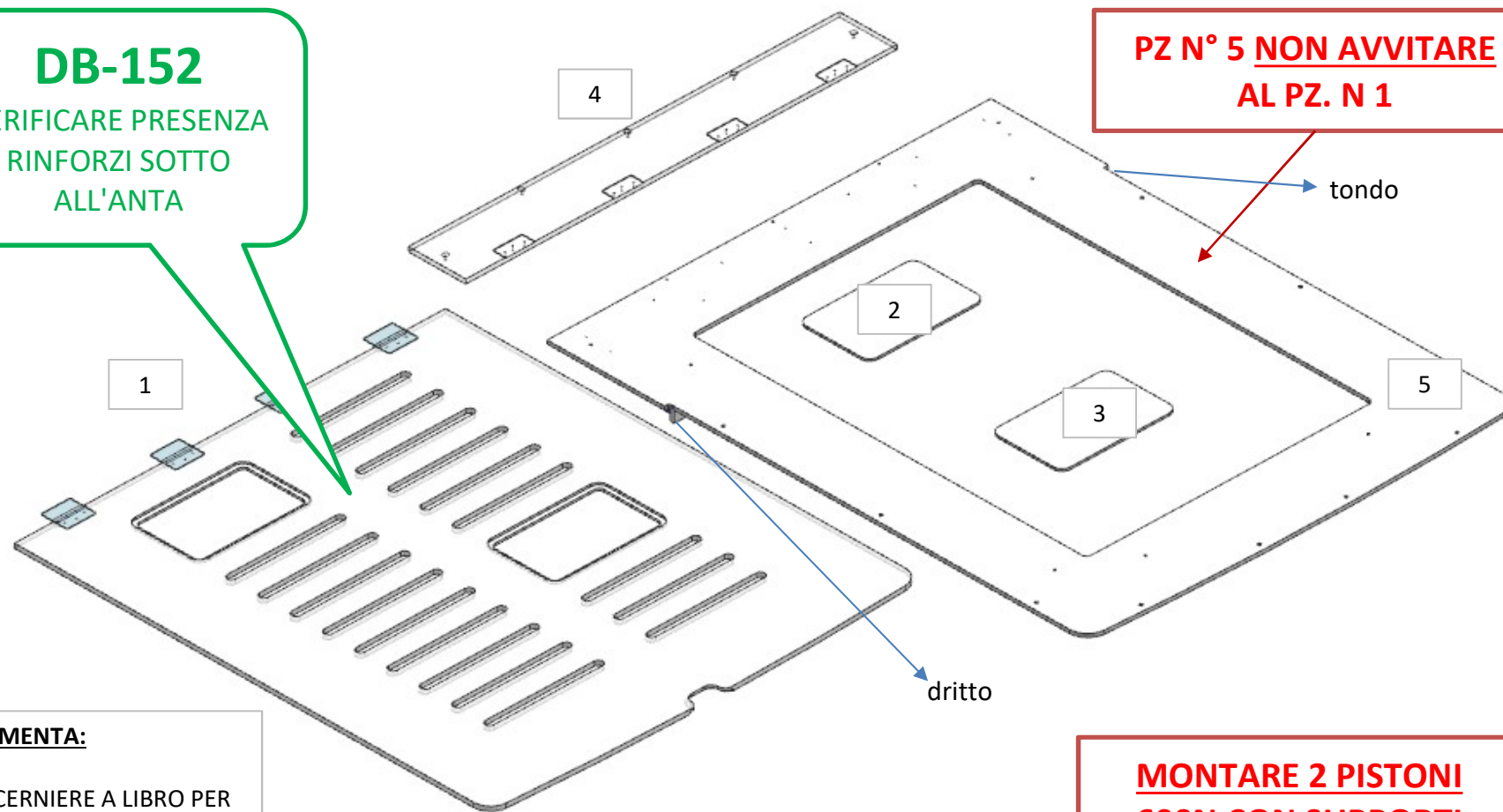

FERRAMENTA:
N° 4 - CERNIERE A LIBRO PER
LETTI

**MONTARE 2 PISTONI
600N CON SUPPORTI**

AZ53F

DA MAT. 207 REV.26-06-2024

LOCALE	CODICE	DESCRIZIONE COMPONENTE	FINITURA	Q.TA	OPERATORE
CABINA ARMATORE	AZ53F-AK01	PLENUM E CARTER FANCOIL SX	VERNICIATO NERO	1	Dante

**SPRUZZARE DI
NERO I PLENUM**

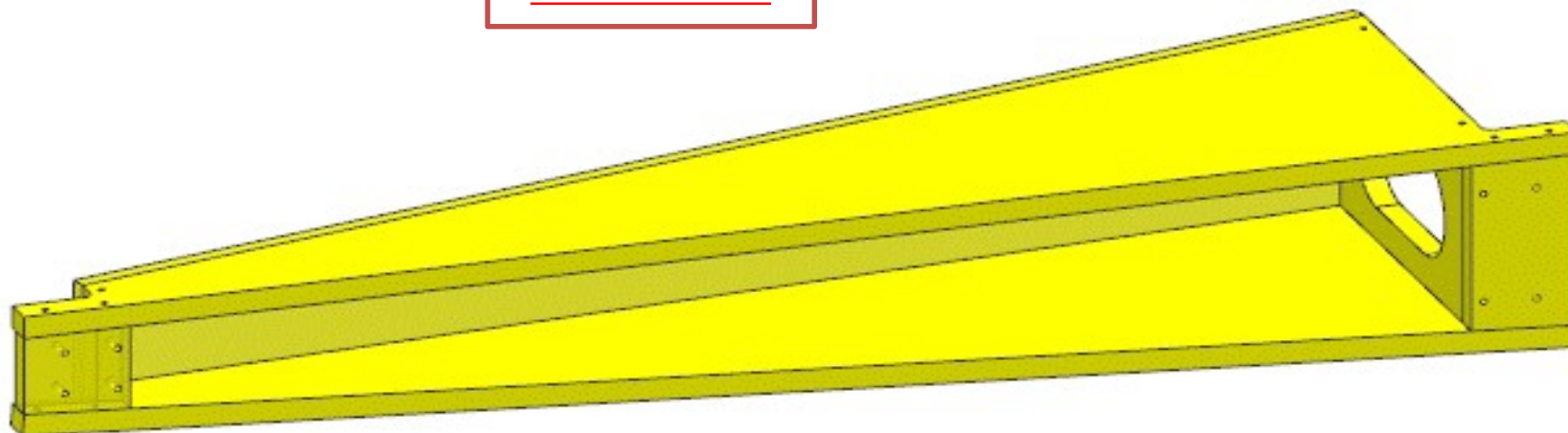

90

IL PANNELLO GREZZO
VIENE FORNITO
ASSIEME AL CODICE

AZ53F

DA MAT. 201 REV.26-06-2024

LOCALE	CODICE	DESCRIZIONE COMPONENTE	FINITURA	Q.TA	OPERATORE
CABINA ARMATORE	AZ53F-AM01	RIV. TESTATA ALTA POPPA	OKOUME' GREZZO	2	Damiano

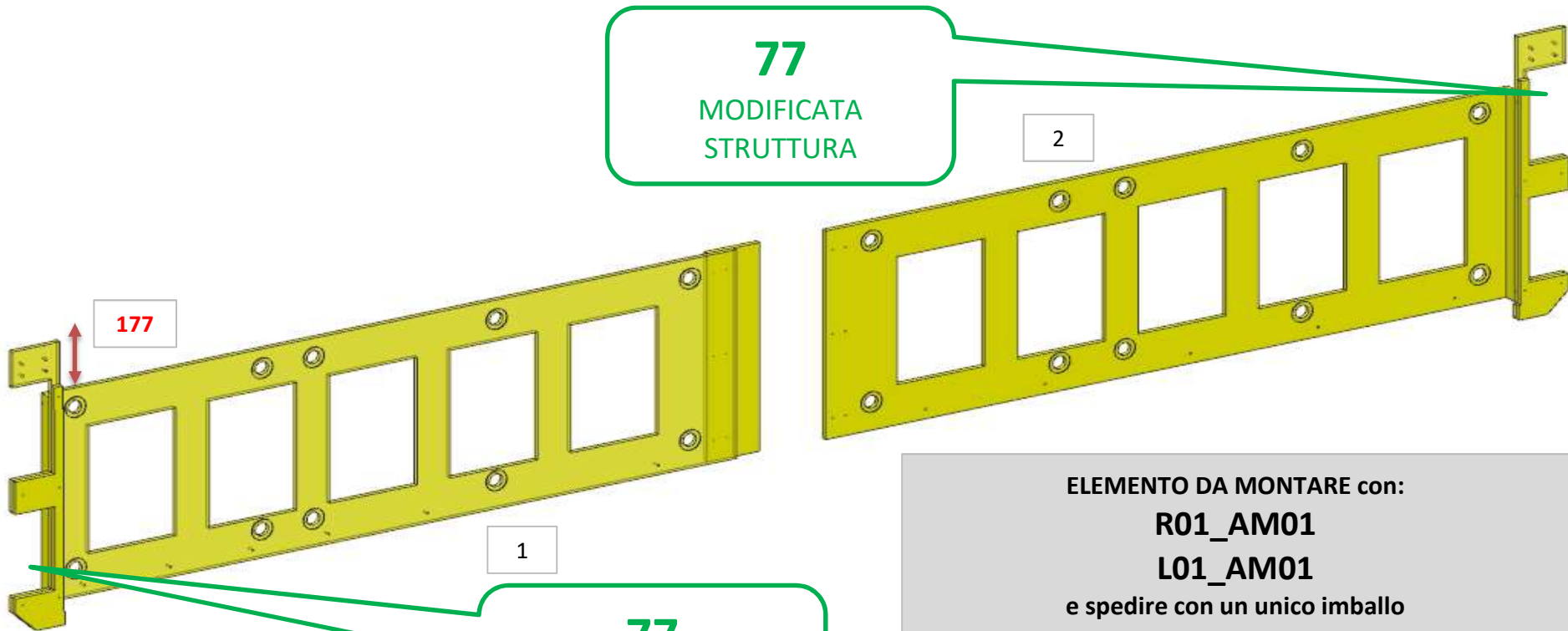

FERRAMENTA:
N° 20 - FITLOCK
N° 8 - BUSSOLA ZAMA 6MA
N° 11 - VITI 6MA



AZ53F

DA MAT. 201 - 207 REV.26-06-2024

LOCALE	CODICE	DESCRIZIONE COMPONENTE	FINITURA	Q.TA	OPERATORE
CABINA ARMATORE	AZ53F-_AN01	FINESTRATURA A.C. DX	OKOUME\LAMINATO	1	Damiano

40

MODIFICATA STRUTTURA
(PRIMA ERA DRITTA)

90
da mat
207
FATTO
TAGLIO

46

TOLTO LA PARTE
SOTTO DELLA
STRUTTURA

FERRAMENTA:

- N° 6 - FITLOCK
- N° 6 - FAST MOUNT
- N° 8 - BUSSOLA ZAMA 6MA
- N° 4 - VITI 6MA

ELEMENTO DA MONTARE con:
L01_AN01
e spedire con un unico imballo

L01_AN01

AZ53F

REV.26-06-2024

LOCALE	CODICE	DESCRIZIONE COMPONENTE	FINITURA	Q.TA	OPERATORE
CABINA ARMATORE	AZ53F-_AO01	FINISTRATURA A.C. SX	OKOUME\LAMINATO	1	Damiano

40
MODIFICATA
STRUTTURA A "U"
(PRIMA ERA DRITTA)

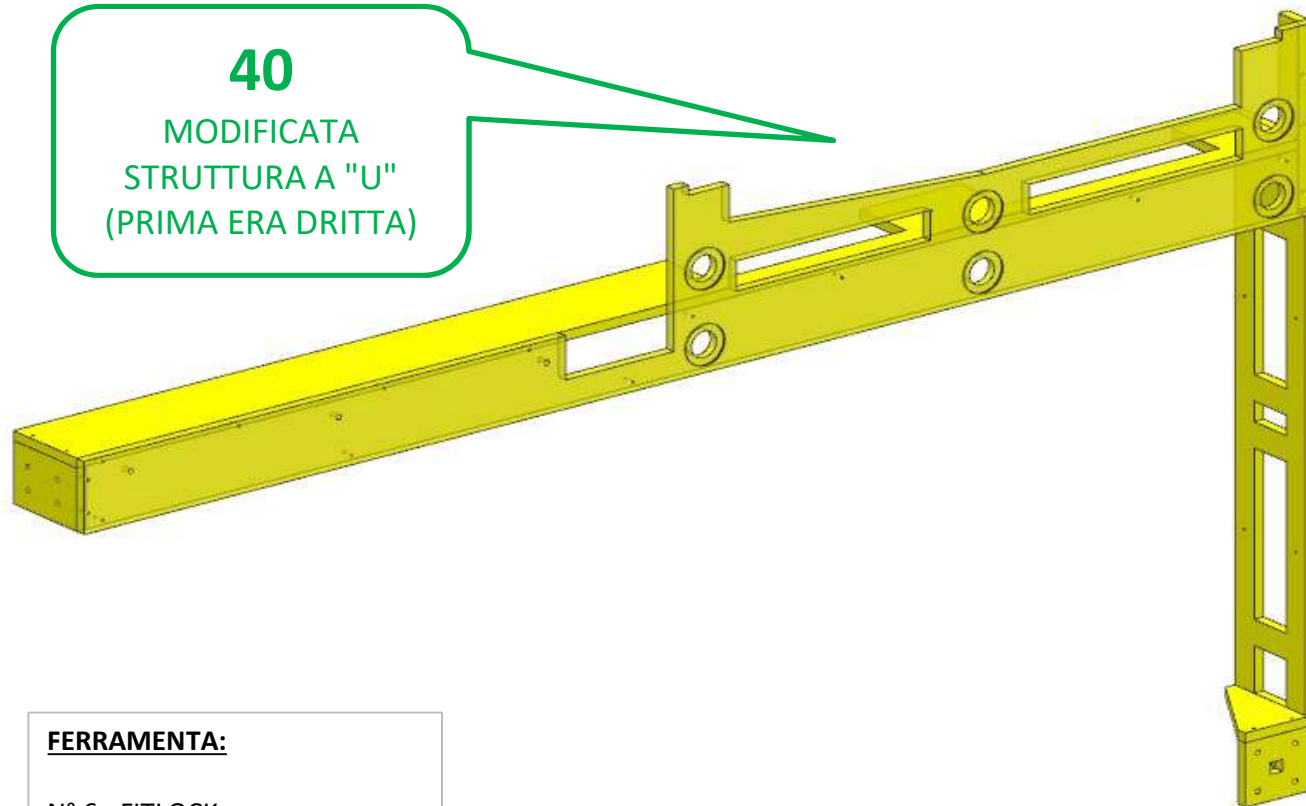

FERRAMENTA:

- N° 6 - FITLOCK
- N° 6 - FAST MOUNT
- N° 8 - BUSSOLA ZAMA 6MA
- N° 4 - VITI 6MA

ELEMENTO DA MONTARE con:
L01_AO01
e spedire con un unico imballo

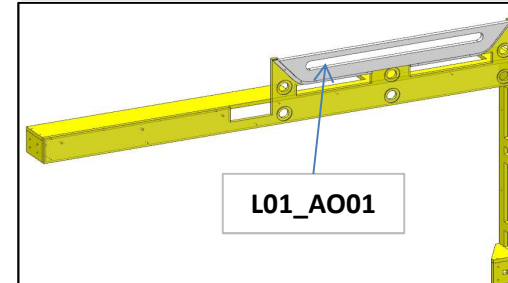

consonni&c

AZ53F

DA MAT. 203 REV.26-06-2024

LOCALE	CODICE	DESCRIZIONE COMPONENTE	FINITURA	Q.TA	OPERATORE
CABINA ARMATORE	AZ53F-_AP01	SOFFITTO POPPA	OKOUME' GREZZO	2	Dante

1 - L.2080 x H.819 x sp 15
2 - L.2060 x H.819 x sp 15

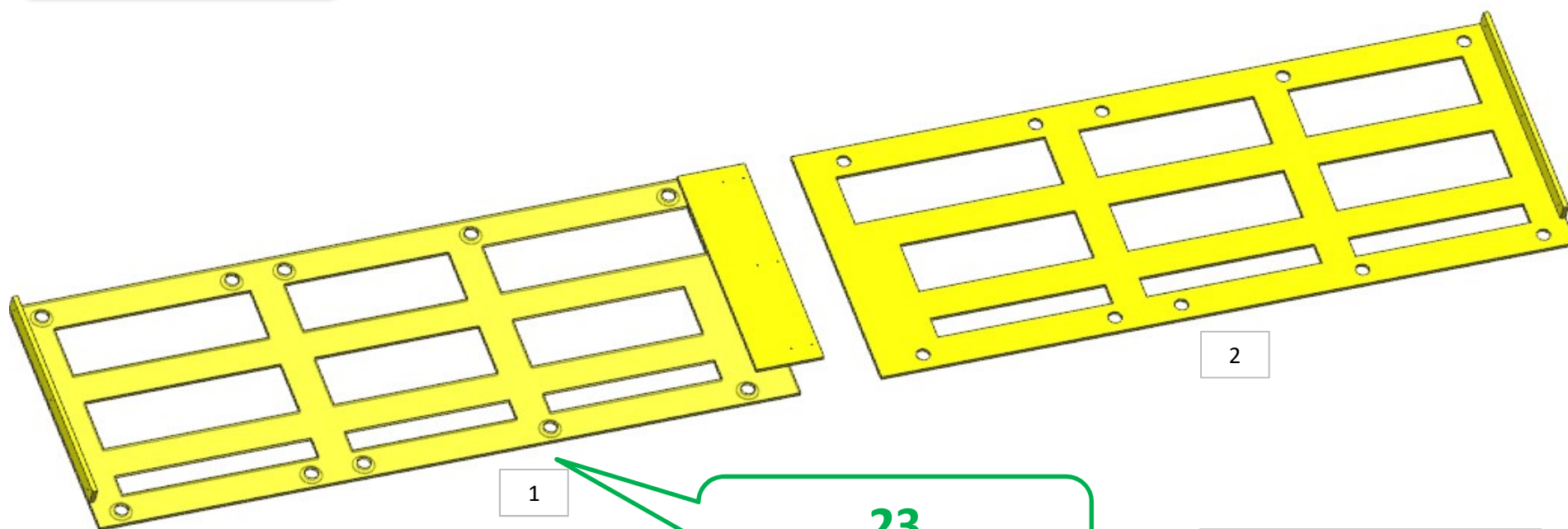

1

2

23

AGGIUNTO FORI FITLOCK

FERRAMENTA:

N° 24 - BUSSOLA ZAMA 6MA
N° 6 - VITI 6MA
N° 20 FITLOCK

AZ53F

DA MAT. 221 REV.26-06-2024

LOCALE	CODICE	DESCRIZIONE COMPONENTE	FINITURA	Q.TA	OPERATORE
CABINA ARMATORE	AZ53F-_AQ01	ARMADIO DRESSING	LAMINATO NADIR	1	Dante

104
ELIMINATO "ALETTA"
MOBILE

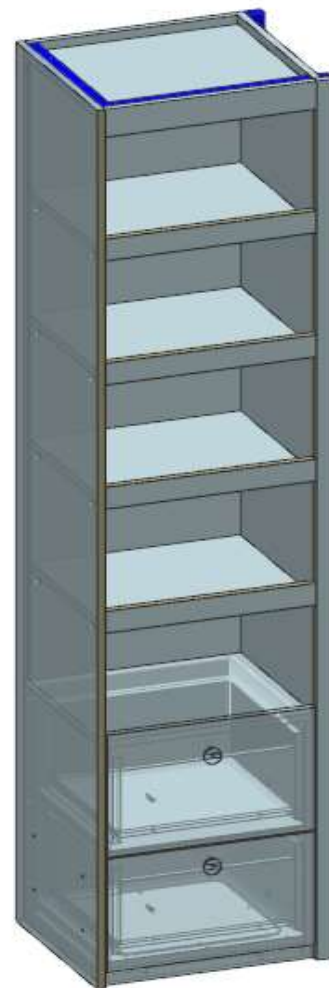

FERRAMENTA:

- N° 16 - REGGIRIPIANI
- N° 2 COPPIE - GUIDA 350
- N° 4 - CALAMITE PER CASSETTI
- N° 2 - FLUSH LOCK
- N° 24 - BUSSOLA ZAMA 6MA
- N° 6 - VITI 6MA

AZ53F

DA MAT. 221 REV.26-06-2024

LOCALE	CODICE	DESCRIZIONE COMPONENTE	FINITURA	Q.TA	OPERATORE
CABINA ARMATORE	AZ53F-AR01	MOBILE FANCOIL DRESSING	LAMINATO NADIR/OKUME' GREZZO	3	Dante

2 - L.432 x H 258 x sp 16
3 - L.466 x H 598 x sp 15

FERRAMENTA:

N° 4 - SOUTCHO
N° 9 - KEKU FRONTALE
N° 4 - BUSSOLA ZAMA 6MA

104

MODIFICATA PARTE
FRONTALE E PAIOLO -
VERIFICARE MISURE)

VERIFICARE MISURA =
L. 32

AZ53F

DA MAT. 221 REV.26-06-2024

LOCALE	CODICE	DESCRIZIONE COMPONENTE	FINITURA	Q.TA	OPERATORE
CABINA ARMATORE	AZ53F-AS01	CIELINO DRESSING	LAMINATO NADIR	1	Dante

1 - L 1222 x H.1041 x sp 16

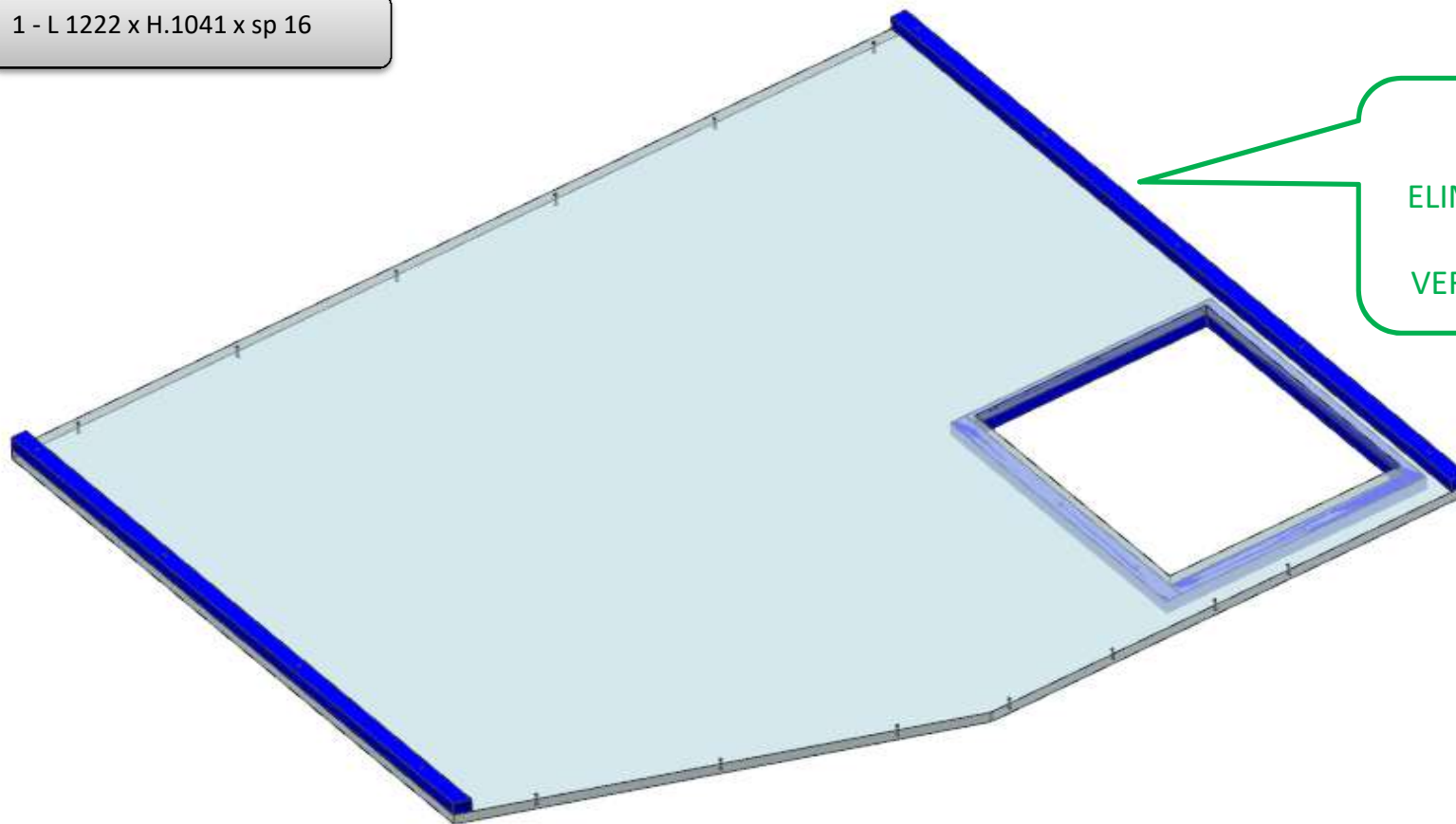

104

ELIMINATO "TACCA"
LATERALE -
VERIFICARE MISURE

AZ53F

DA MAT. 221 REV.26-06-2024

LOCALE	CODICE	DESCRIZIONE COMPONENTE	FINITURA	Q.TA	OPERATORE
CABINA ARMATORE	AZ53F-AT01	SCHIENALI DRESSING	OKOUME' GREZZO\ LAMINATO	5	Dante

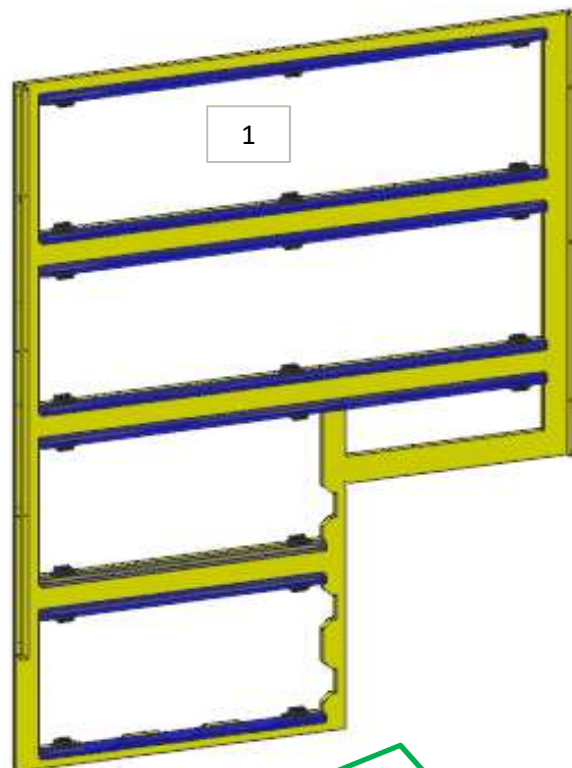
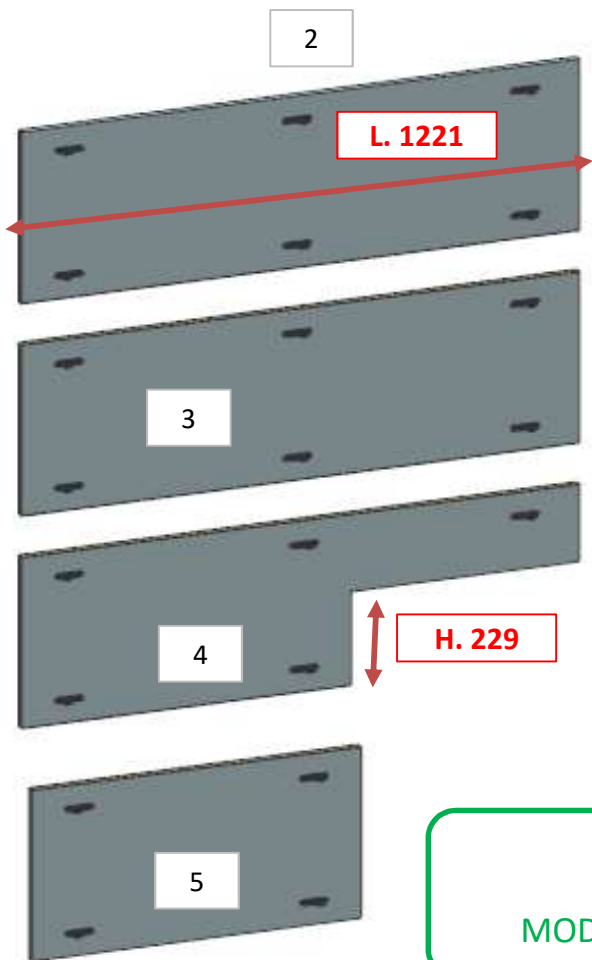

FERRAMENTA:

N° 21 - SOUTCHO

- 1 - L 1222 x H.1679 x sp 15
- 2 - 3 - 4 - L 1221 x H. 419 x sp 16
- 5 - L 721 x H. 419 x sp 16

Elemento da spedire con
un unico imballo

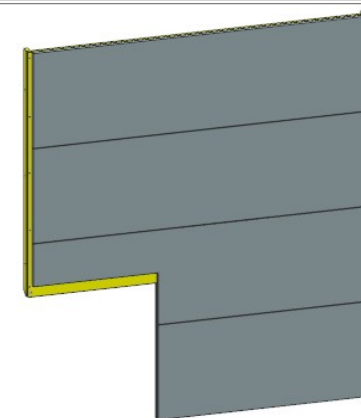

104

MODIFICATO TUTTO - VERIFICARE MISURE

AZ53F

DA MAT. 209 REV.26-06-2024

LOCALE	CODICE	DESCRIZIONE COMPONENTE	FINITURA	Q.TA	OPERATORE
CABINA ARMATORE	AZ53F-AU01	ARMADIO SOTTO SCALA	LAMINATO NADIR	4	Damiano

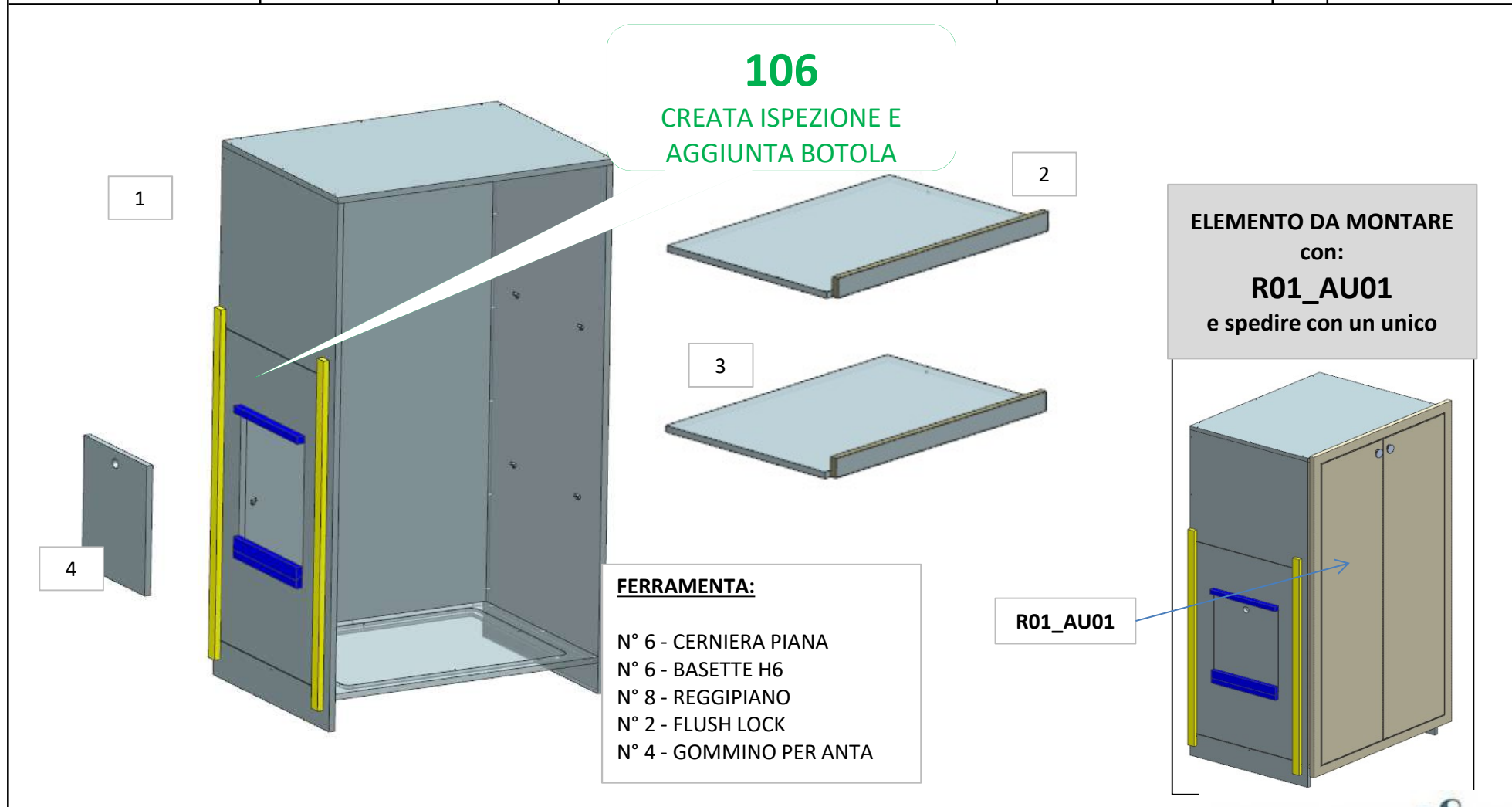

AZ53F

268

REV.26-06-2024

LOCALE	CODICE	DESCRIZIONE COMPONENTE	FINITURA	Q.TA	OPERATORE
CABINA ARMATORE	AZ53F-AV01	PANNELLI INTERNO DRESSING	LAMINATO NADIR	1	Dante

1 - L 480 x H 1965 x sp 16

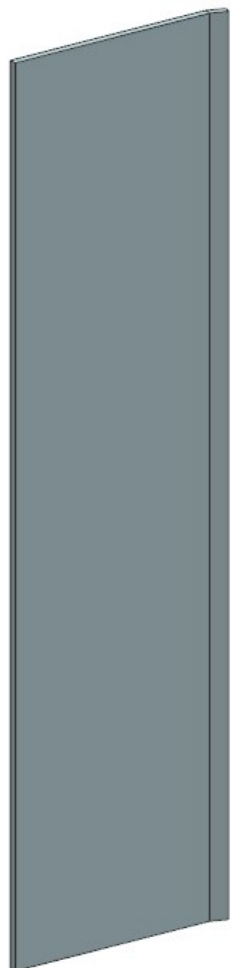

LATO BELLO

DETTAGLIO



AZ53F

REV.26-06-2024

LOCALE	CODICE	DESCRIZIONE COMPONENTE	FINITURA	Q.TA	OPERATORE
CABINA ARMATORE	AZ53F-AW01	PLENUM E CARTER FANCOIL DX	OKOUME' GREZZO	4	Dante

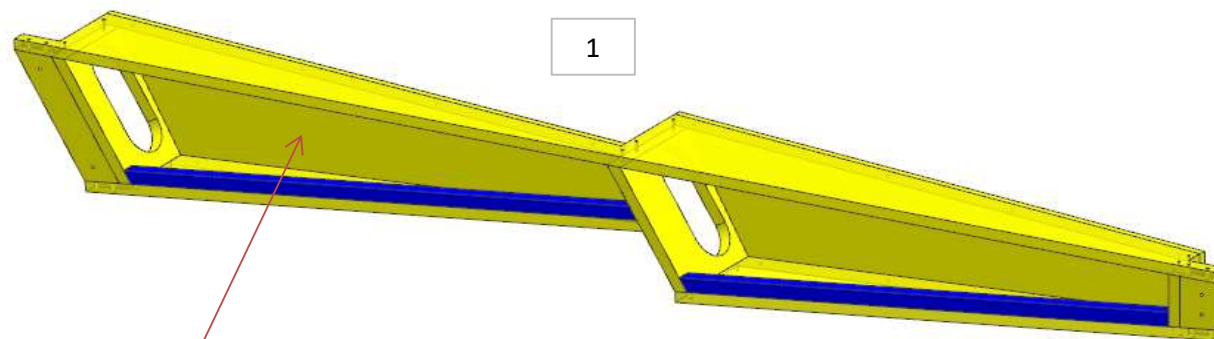

SPRUZZARE DI NERO I PLENUM

4

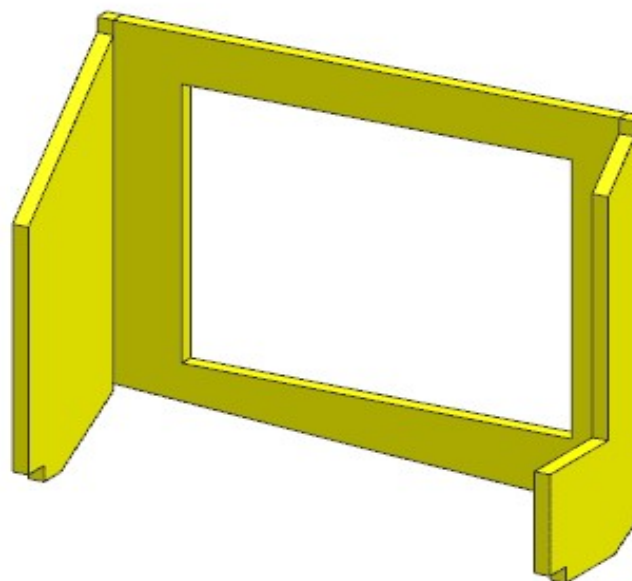

3

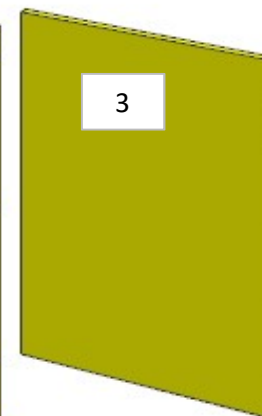

2

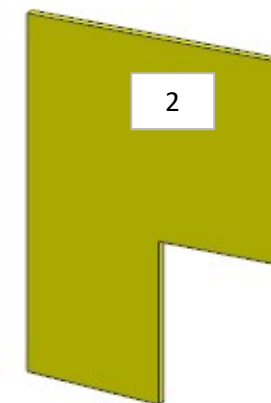

AZ53F

DA MAT. 201 REV.26-06-2024

LOCALE	CODICE	DESCRIZIONE COMPONENTE	FINITURA	Q.TA	OPERATORE
CABINA ARMATORE	AZ53F-AY01	MURETTO RETRO DIVANO STD	OKOUME' GREZZO	3	Damiano

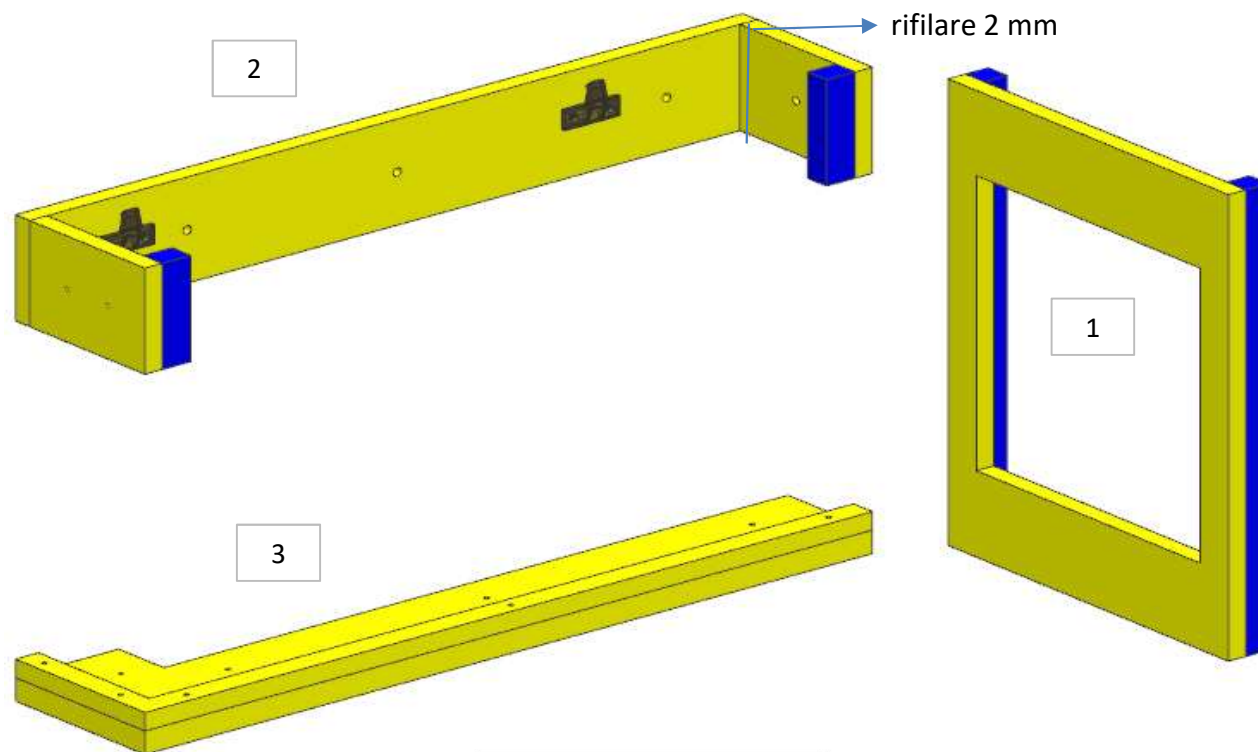

**AGGIUNTO
CODICE**

ELEMENTI DA MONTARE CON:
R01_AY01
L01_AY01
e spedire con un unico imballo

- 1 - L 299 x H 378 x sp 15
- 2 - L 635 x H 86 x 138
- 3 - L 635 x H 34 x 138

L01_AY01

R01_AY01

