

# AZ53F

## MODIFICATA CODIFICA DA MAT. 221

REV.26-06-2024

LOCALE	CODICE	DESCRIZIONE COMPONENTE	FINITURA	Q.TA	OPERATORE
CABINA ARMATORE	AZ53F-I01_AAW01	MOBILE CONTENITORE MURATA DX	OKOUME' GREZZO	2	Dante

1 - SVILUPPO L 2996 x H180 x sp 56

**179**

UNITO PARTE DRITTA CON CURVATO -  
DIVENTATO 1 UNICO PZ

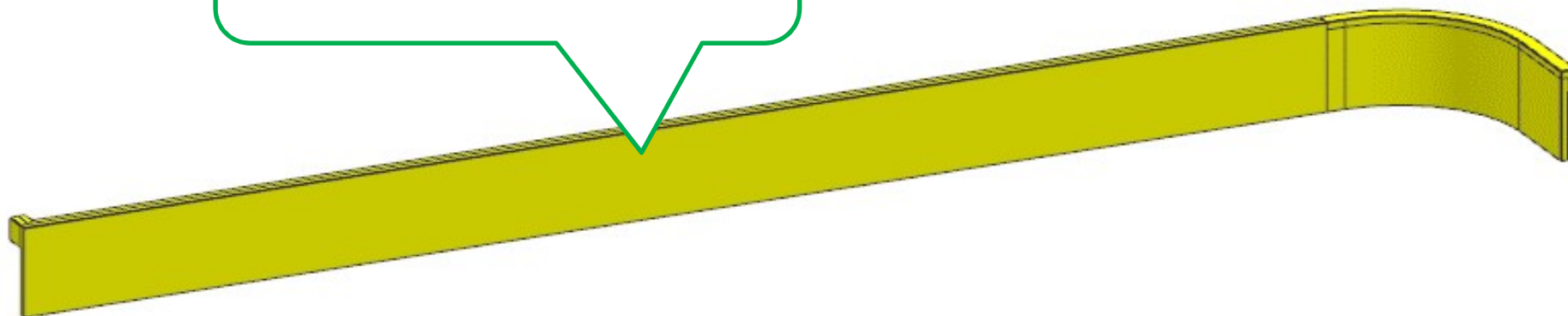

# AZ53F

DA MAT. 221 REV.26-06-2024

LOCALE	CODICE	DESCRIZIONE COMPONENTE	FINITURA	Q.TA	OPERATORE
CABINA ARMATORE	AZ53F-I01_AAX01	MOBILE CONTENITORE MURATA DX	OKOUME' GREZZO	1	Damiano

1 - L 1202 x H 413 x sp 6

**178**  
MODIFICATO MISURE



ELEMENTO DA MONTARE con:

R01\_AAX01  
L01\_AAX01  
L02\_AAX01  
AAX01

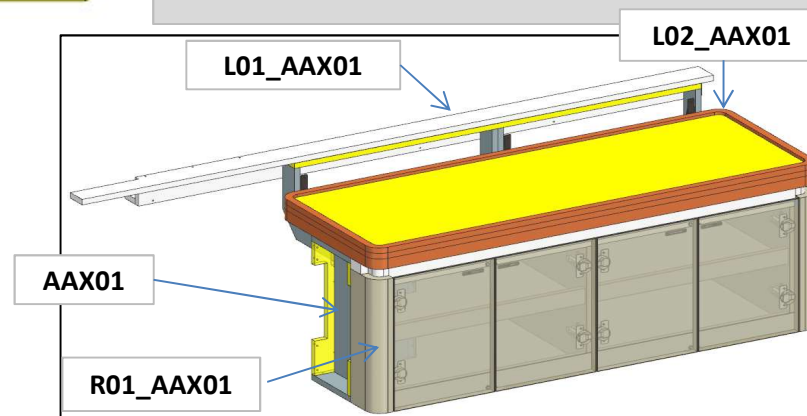

# AZ53F

DA MAT. 221 REV.26-06-2024

LOCALE	CODICE	DESCRIZIONE COMPONENTE	FINITURA	Q.TA	OPERATORE
CABINA ARMATORE	AZ53F-I01_AB01	STRUTTURA RETRO COMODINO DX	OKOUME' GREZZO	1	Dante

1 - L 524 x H 610 x sp 30

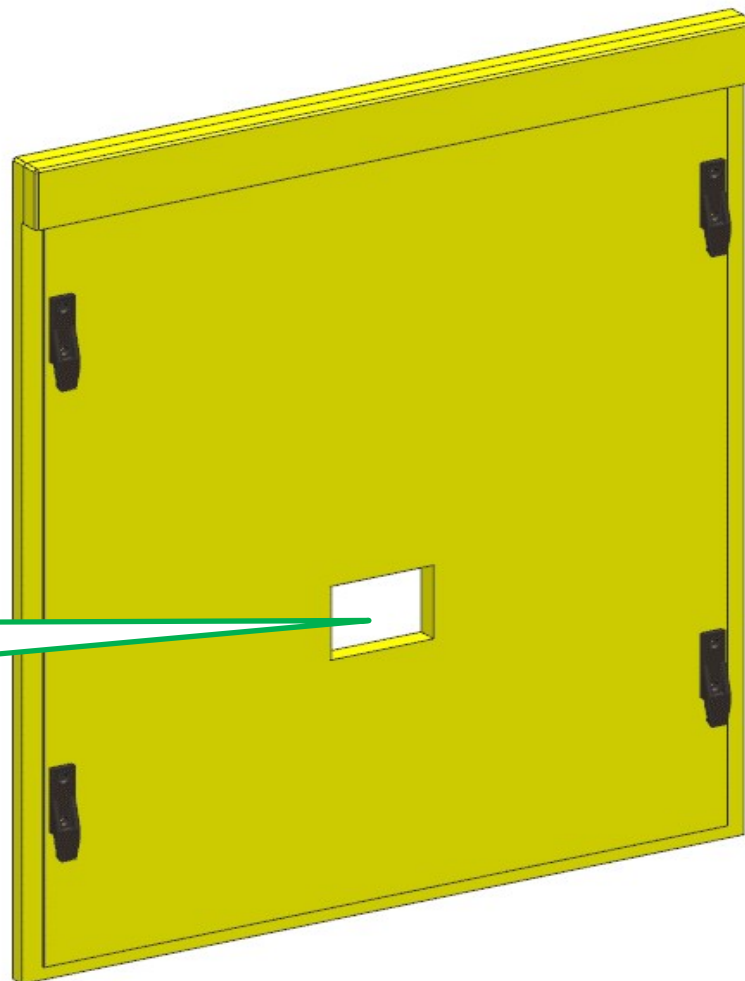

**174**  
FATTO FORO

# AZ53F

REV.26-06-2024

LOCALE	CODICE	DESCRIZIONE COMPONENTE	FINITURA	Q.TA	OPERATORE
CABINA ARMATORE	AZ53F-I01_AC01	COMODINO DX	OKOUME' GREZZO	1	Damiano

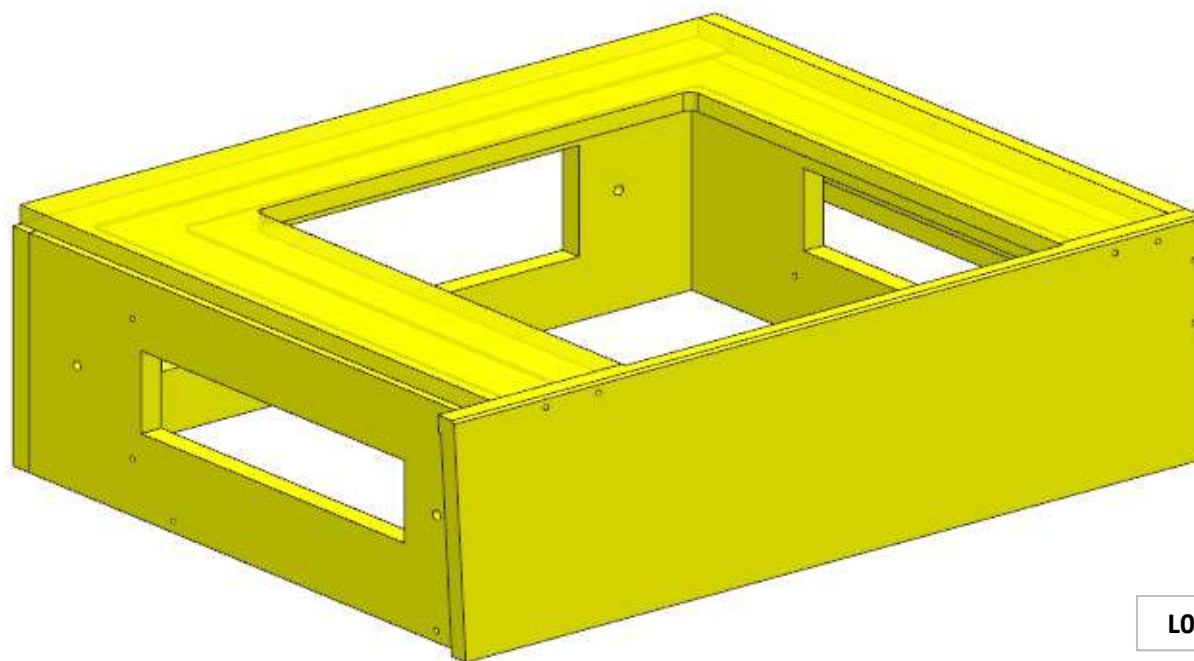

ELEMENTO DA MONTARE con:  
**R01\_AC01**  
**L01\_AC01**  
**AC01**  
e spedire con un unico imballo

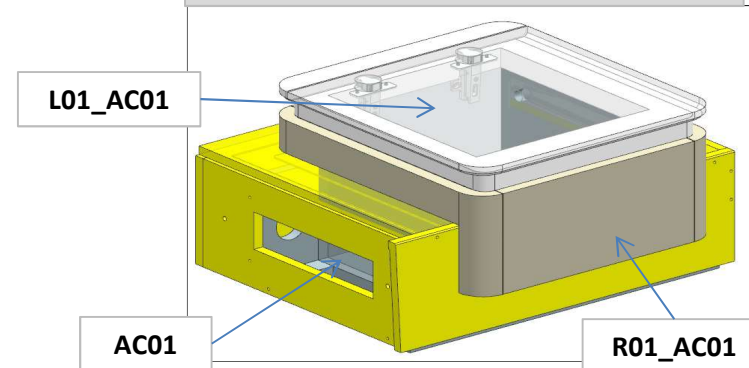

# AZ53F

DA MAT. 201 REV.26-06-2024

LOCALE	CODICE	DESCRIZIONE COMPONENTE	FINITURA	Q.TA	OPERATORE
CABINA ARMATORE	AZ53F-I01_AD01	STRUTTURA RETRO LETTO	OKOUME' GREZZO	1	Dante

1 - L. 1592 x H.700 x sp 30

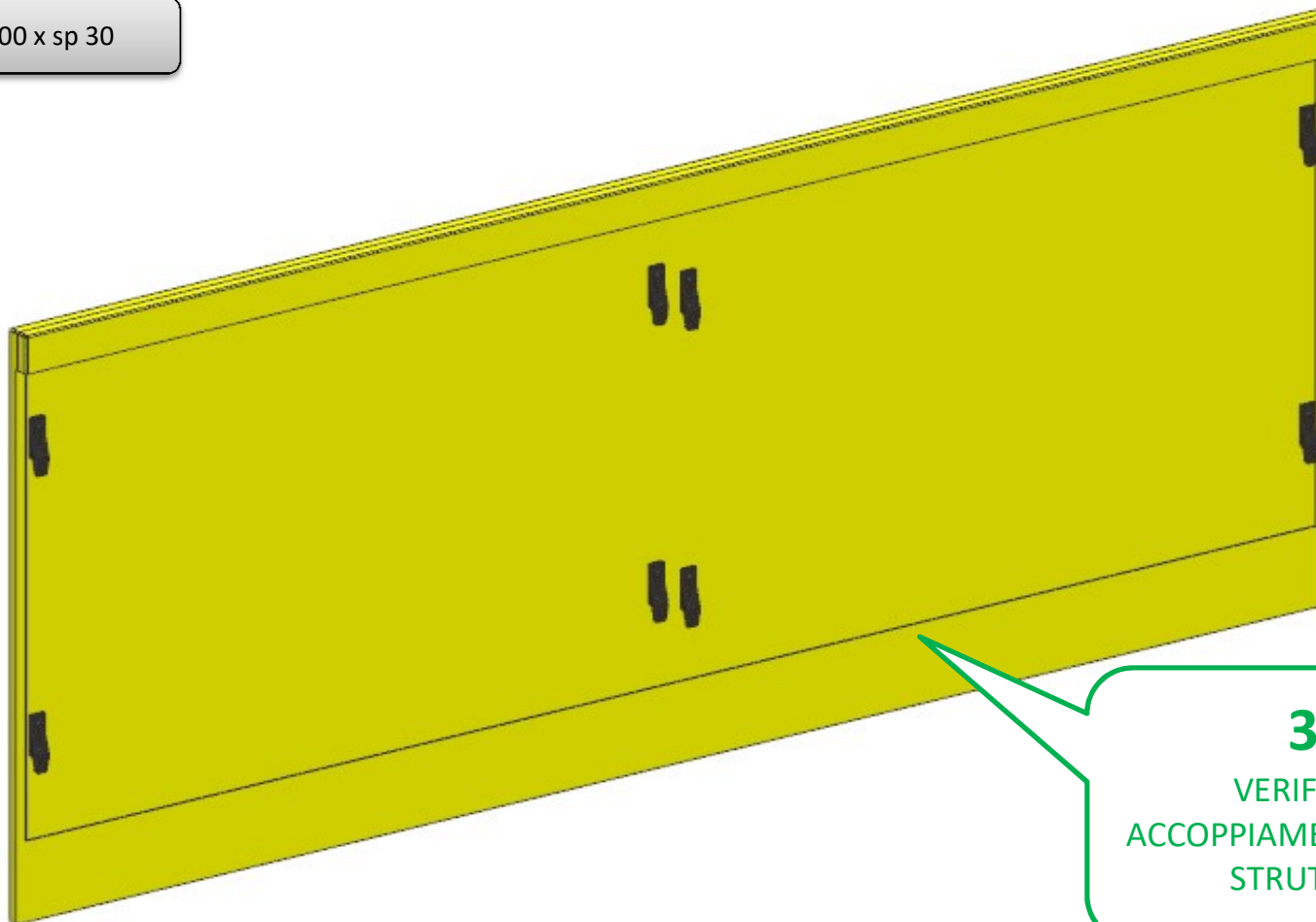

**32**  
VERIFICARE  
ACCOPIAMENTO CON LA  
STRUTTURA

# AZ53F

DA MAT. 221 REV.26-06-2024

LOCALE	CODICE	DESCRIZIONE COMPONENTE	FINITURA	Q.TA	OPERATORE
CABINA ARMATORE	AZ53F-I01_AE01	STRUTTURA RETRO COMODINO SX	OKOUME' GREZZO	1	Dante

**174**  
FATTO FORO

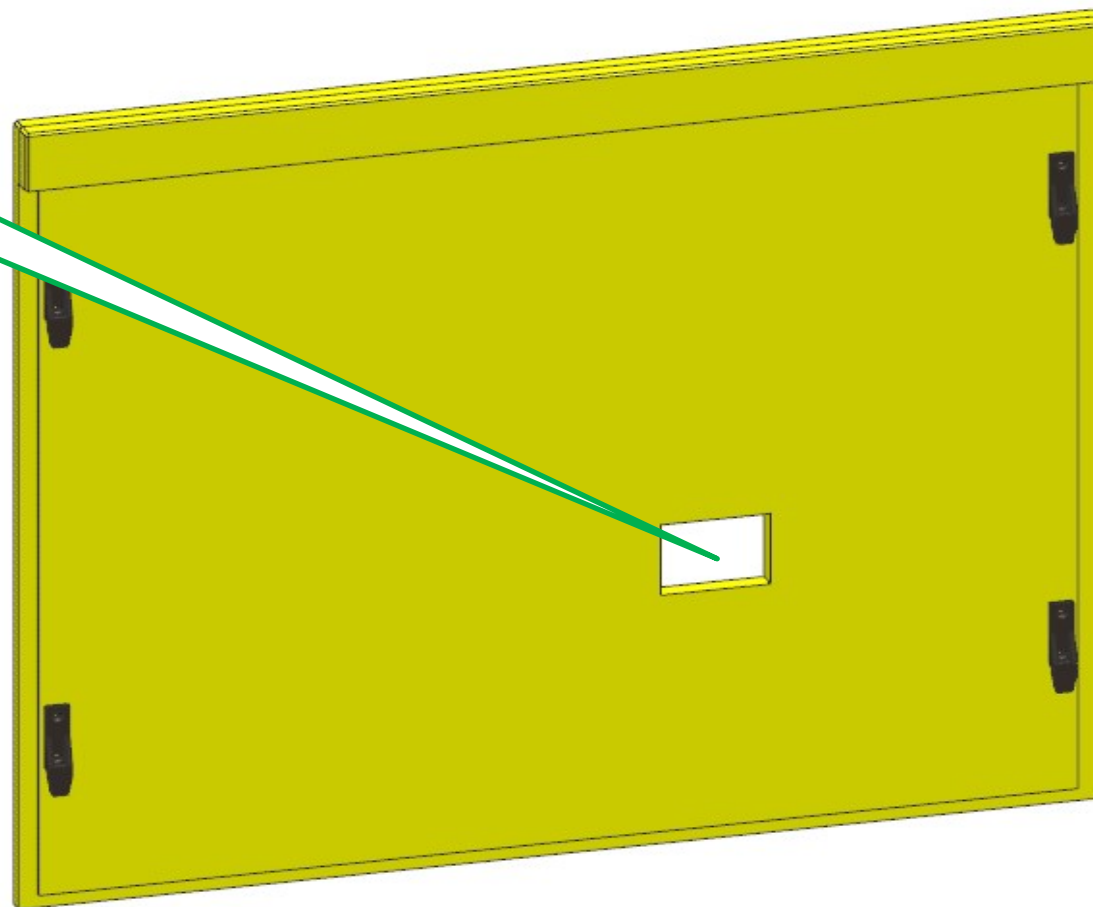

# AZ53F

DA MAT. 201 REV.26-06-2024

LOCALE	CODICE	DESCRIZIONE COMPONENTE	FINITURA	Q.TA	OPERATORE
CABINA ARMATORE	AZ53F-I01_AF01	COMODINO SX	OKOUME' GREZZO	1	Damiano

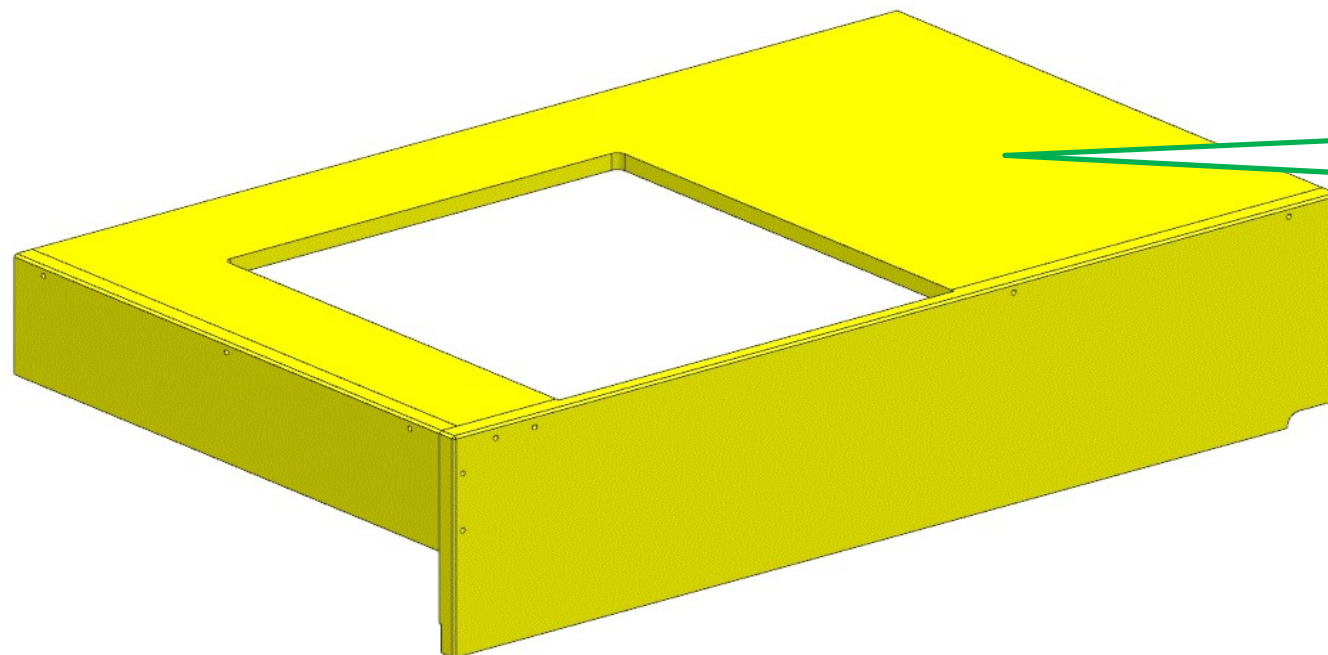

**85**  
ELIMINATO FORO

ELEMENTO DA MONTARE con:  
**R01\_AF01**  
**L01\_AF01**  
**AF01**  
e spedire con un unico imballo

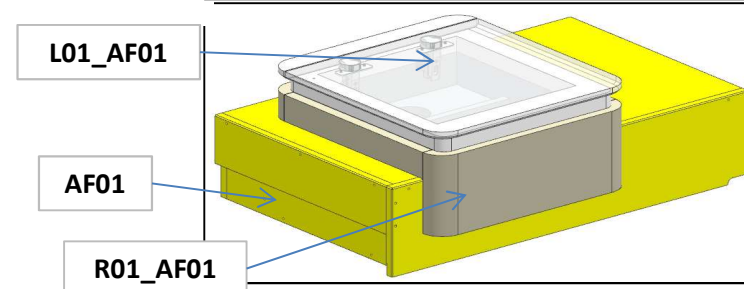

# AZ53F

DA MAT. 221 REV.26-06-2024

LOCALE	CODICE	DESCRIZIONE COMPONENTE	FINITURA	Q.TA	OPERATORE
CABINA ARMATORE	AZ53F-I01_AG01	STRUTTURA ANGOLO DIVANO	OKOUME' GREZZO	1	Dante

1 - SVILUPPO L 2625 x H 193 x sp 57

**179**

UNITO PARTE DRITTA CON CURVATO -  
DIVENTATO 1 UNICO PZ

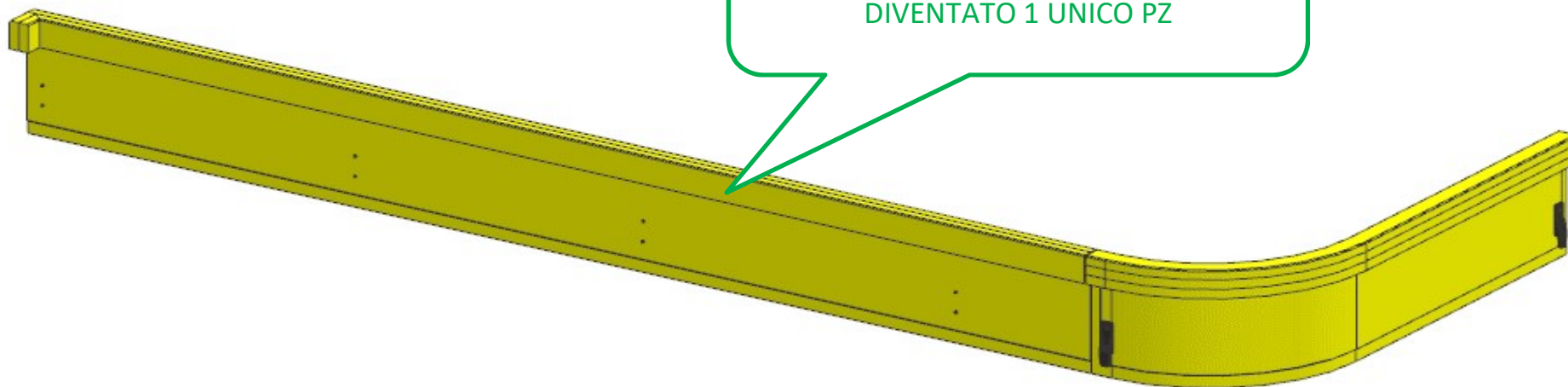

# AZ53F

DA MAT. 214 REV.26-06-2024

LOCALE	CODICE	DESCRIZIONE COMPONENTE	FINITURA	Q.TA	OPERATORE
CABINA ARMATORE	AZ53F-I01_AI01	RETE LETTO	OKOUME' GREZZO	3	Dante

1 - 3 - L.1463 x H.171 x sp 15  
2 - sviluppo L.1728 x H.171 x sp 15

MANDARE VIA  
UNITI

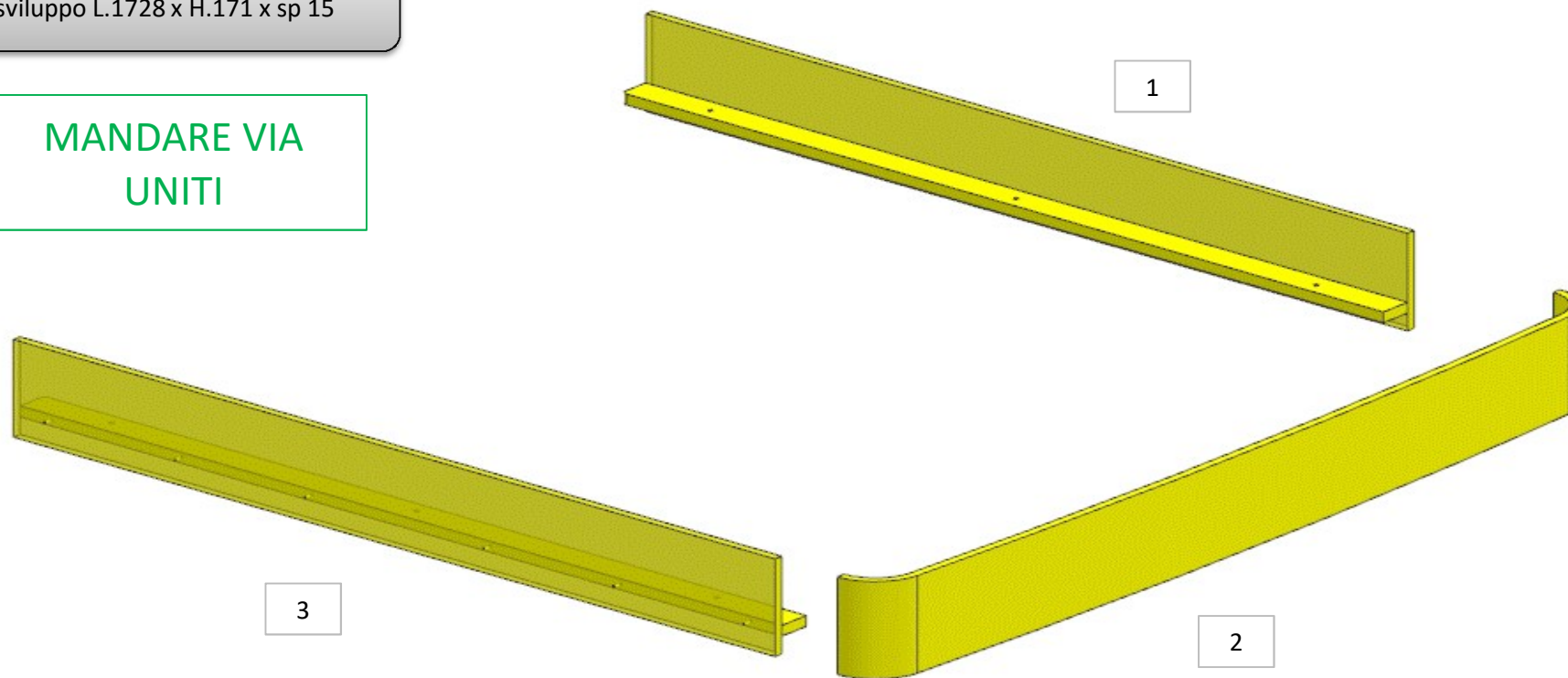

# AZ53F

DA MAT. 207 REV.26-06-2024

LOCALE	CODICE	DESCRIZIONE COMPONENTE	FINITURA	Q.TA	OPERATORE
CABINA ARMATORE	AZ53F-_I01_AN01_01	FINISTRATURA A.C. DX	OKOUME' GREZZO	11	Dante

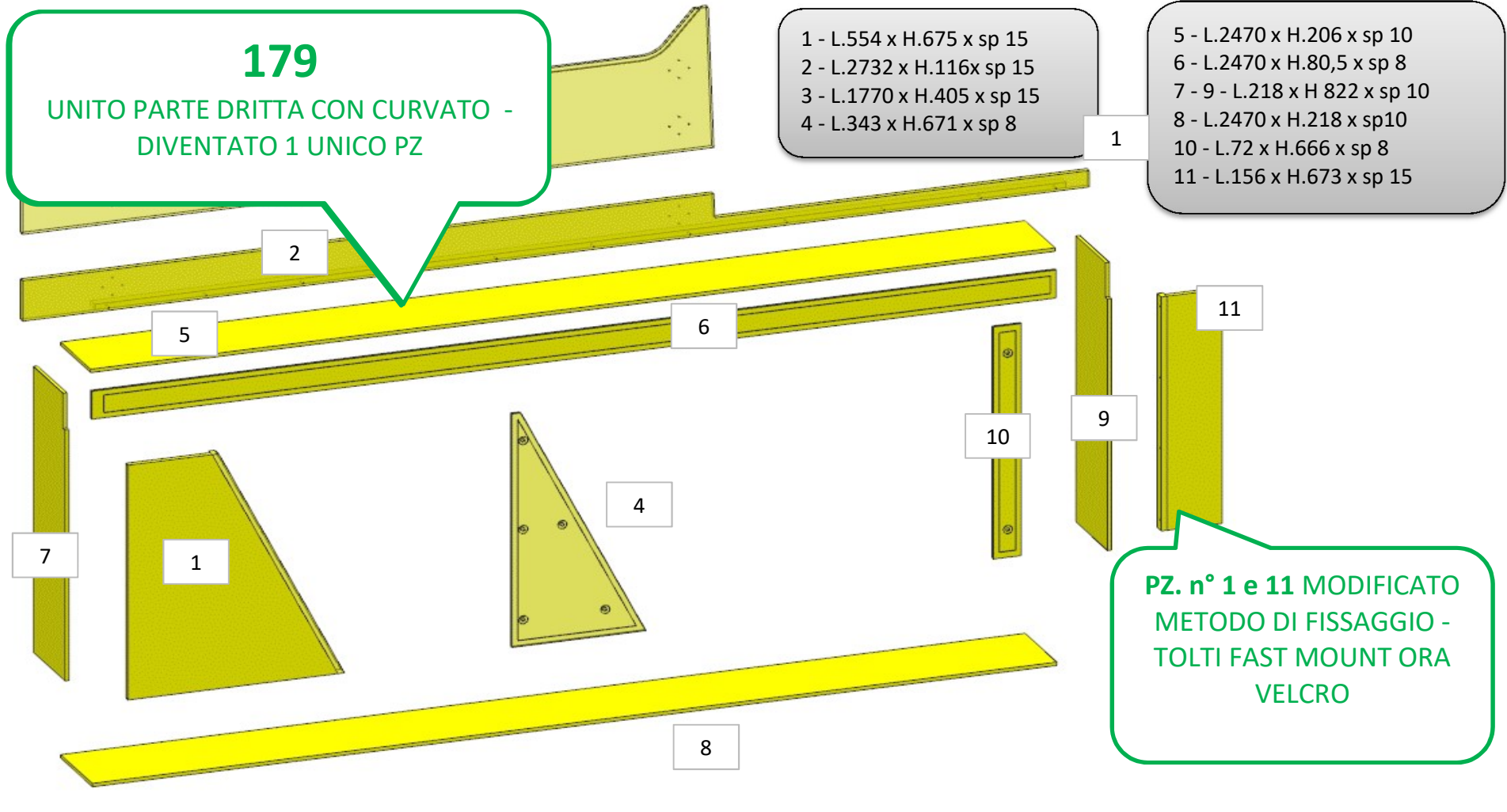

# AZ53F

DA MAT. 207 REV.26-06-2024

LOCALE	CODICE	DESCRIZIONE COMPONENTE	FINITURA	Q.TA	OPERATORE
CABINA ARMATORE	AZ53F-_I01_AO01	FINISTRATURA A.C. SX	OKOUME' GREZZO	11	Dante

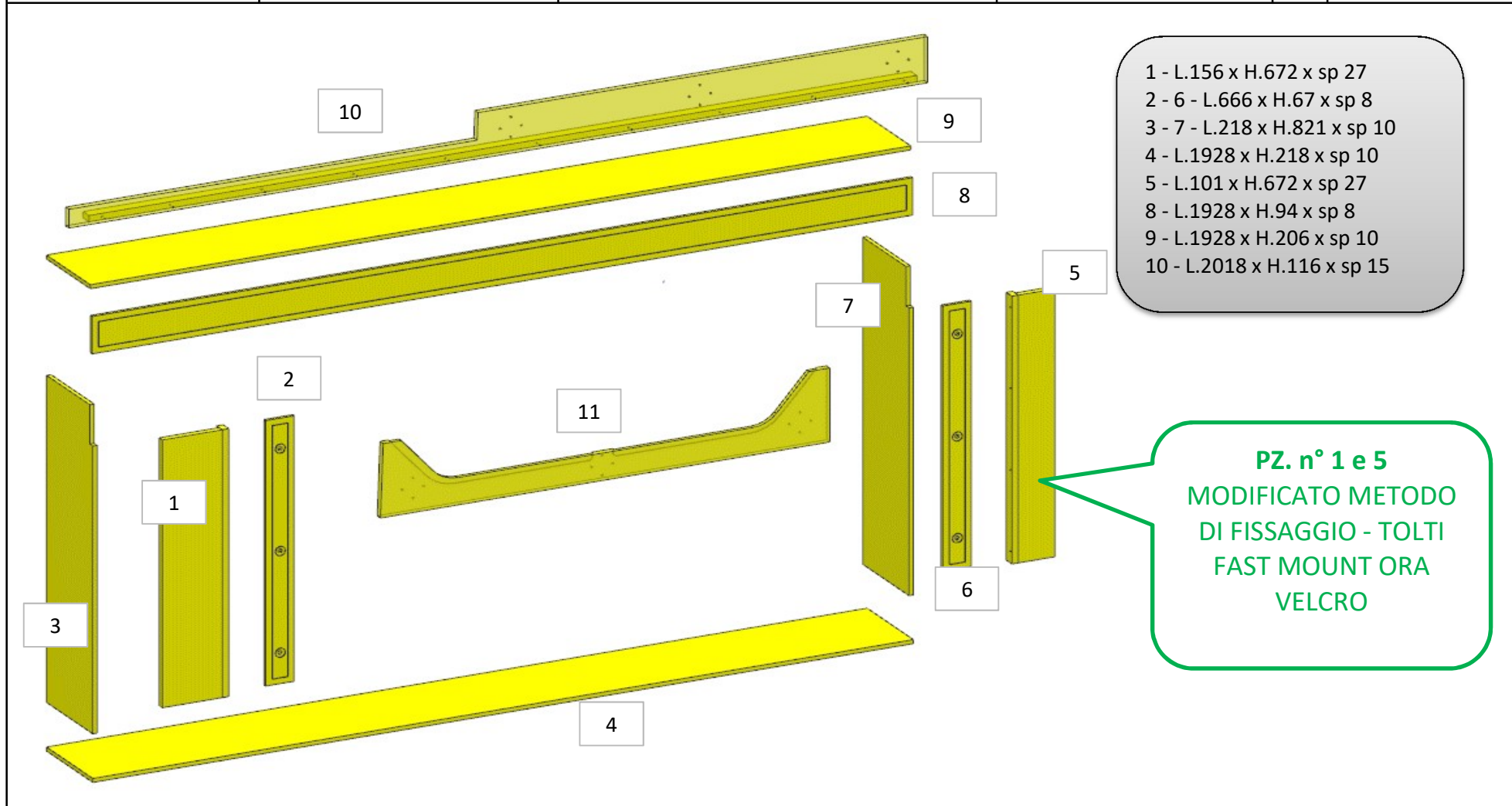

# AZ53F

REV.26-06-2024

LOCALE	CODICE	DESCRIZIONE COMPONENTE	FINITURA	Q.TA	OPERATORE
CABINA ARMATORE	AZ53F-I01_AZ01	PANNELLI CIELINO CABINA	OKOUME' GREZZO	5	Dante

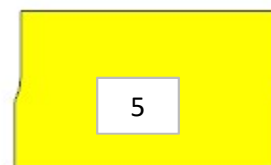
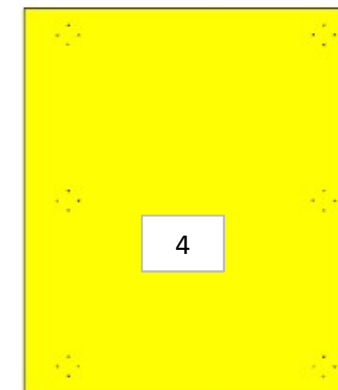
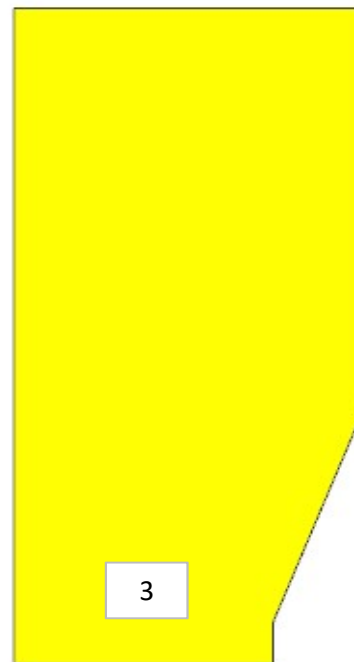
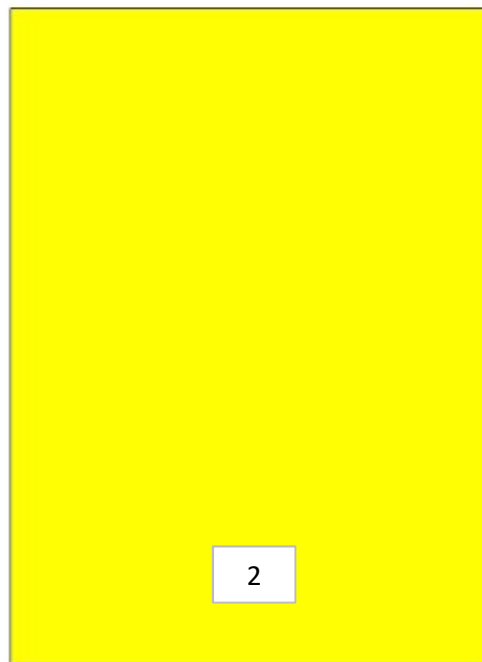
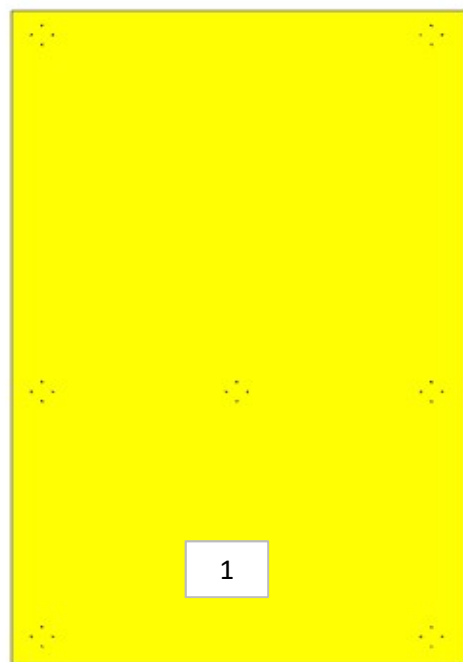

- 1 - L.1088 x H 1733 x sp 10
- 2 - L.1150 x H 1740 x sp 10
- 3 - L.852 x H 1740 x sp 10
- 4 - L.789 x H 1023 x sp 10
- 5 - L.650 x H 418 x sp 10

**FERRAMENTA:**  
N° 13 - FITLOCK