

AZ68F

DA MAT. 216 REV. 25-05-2021

LOCALE	CODICE	DESCRIZIONE COMPONENTE	FINITURA	Q.TA	OPERATORE
SALONE	AZ68F-I01_SA01	COLONNA SX	OKOUME' GREZZO	8	Damiano

238
MIGLIORATA
FINITURA INTERNA
VANI

- 1 - L 100 x H 2010 x sp 15 mm
- 2 - L 504 x H 429.5 x 71.5 mm
- 3 - L 520 x H 850.5 x sp 71.5 mm
- 4 - L 71.5 x H 724 x sp 16 mm
- 5 - L 465 x H 684 x sp 10 mm
- 6 - L 500 x H 720 x sp 25 mm
- 7 - L 667.5 x H 720 x sp 28 mm
- 8 - L 560 x H 353 x sp 15 mm

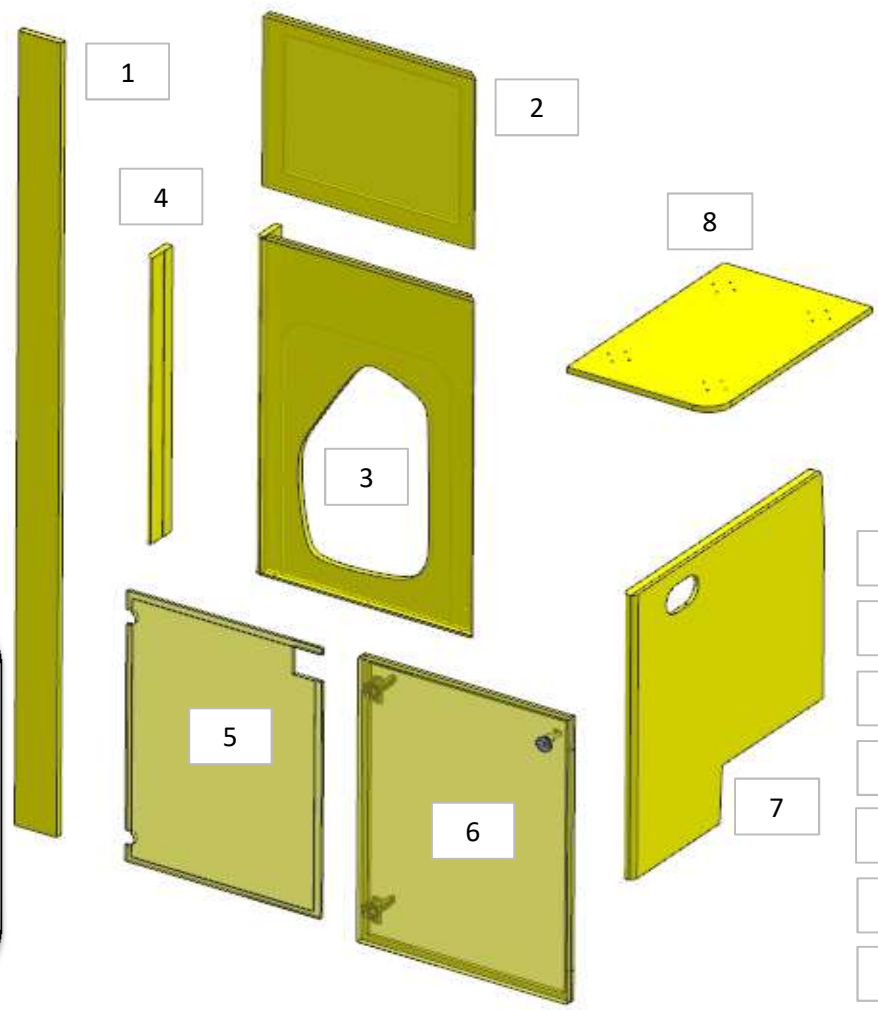

ELEMENTO DA
MONTARE con:
SA01
R01_SA01
R02_SA01
L01_SA01
L02_SA01
P01_SA01
X01_SA01
e spedire con un unico
imballo

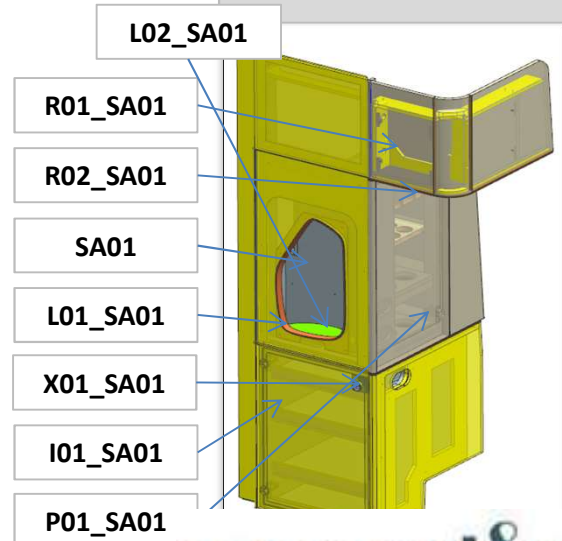

AZ68F

REV. 25-05-2021

LOCALE	CODICE	DESCRIZIONE COMPONENTE	FINITURA	Q.TA	OPERATORE
SALONE	AZ68F-I01_SB01	MURATA BASSA SX POPPA	OKOUME' GREZZO	4	Dante

- 1 - L 426.5 x H 423 x sp 15 mm
- 2 - L 2539 x H 150.5 x sp 15 mm
- 3 - L 578 x H 185 x sp 15 mm
- 4 - L 336.5 x H 182.5 x sp 30 mm

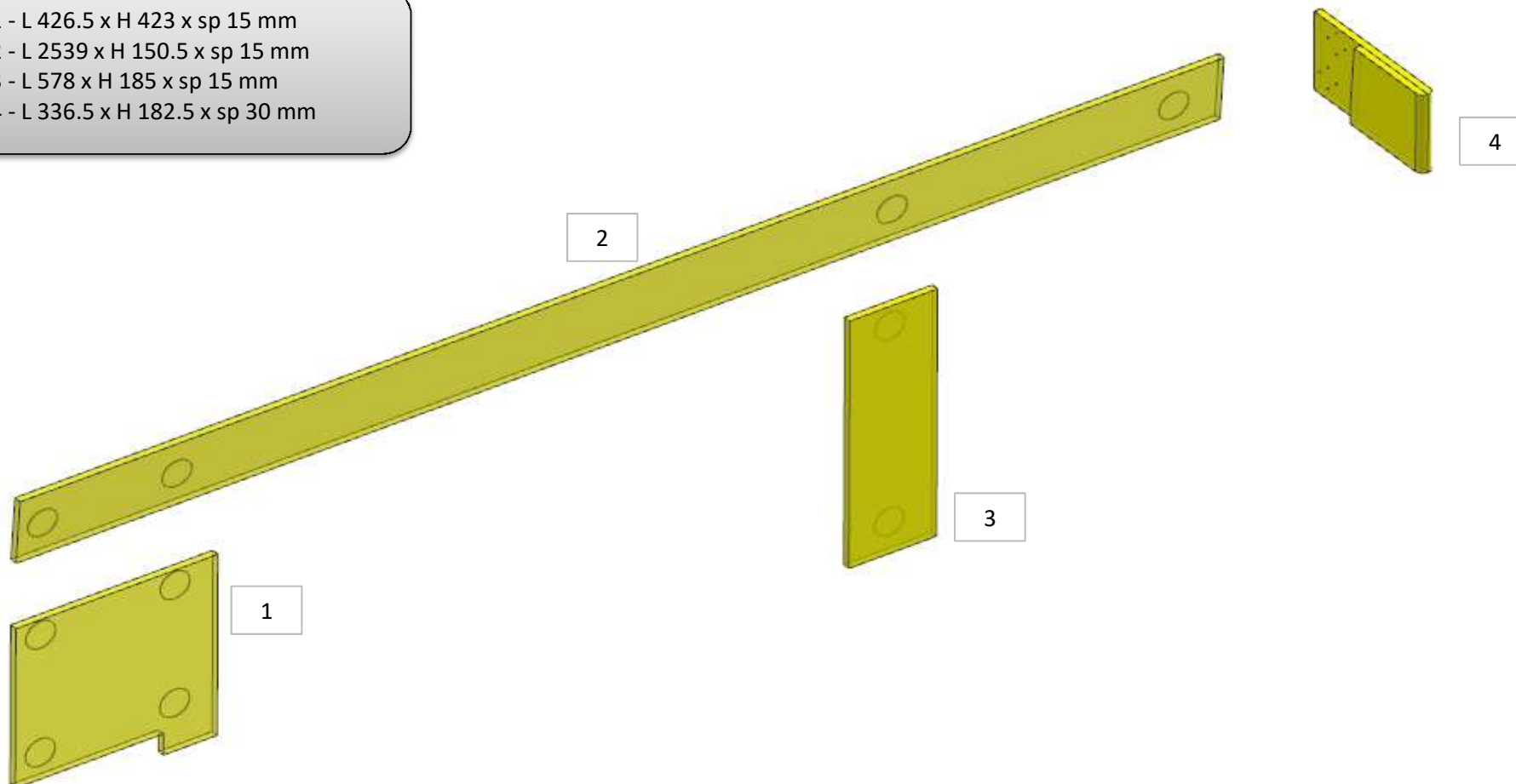

AZ68F

DA MAT. 203 REV. 25-05-2021

LOCALE	CODICE	DESCRIZIONE COMPONENTE	FINITURA	Q.TA	OPERATORE
SALONE	AZ68F-I01_SD01	PLENUM AC MURATA SX	OKOUME' GREZZO	1	Dante

1 - L 2122.5 x H 61.5 x sp 10 mm

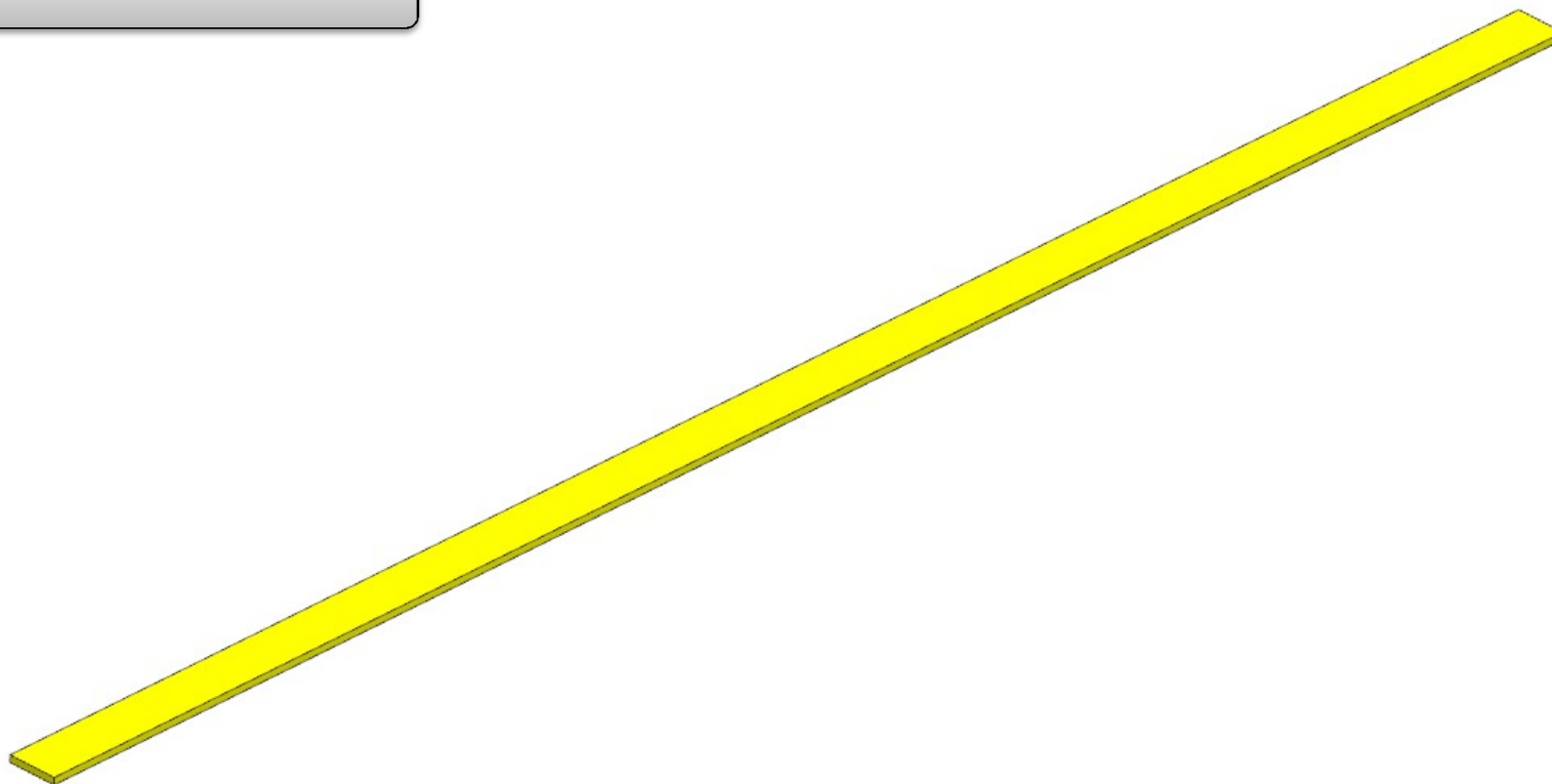

AZ68F

DA MAT. 203 REV. 25-05-2021

LOCALE	CODICE	DESCRIZIONE COMPONENTE	FINITURA	Q.TA	OPERATORE
SALONE	AZ68F-I01_SE01	MURATA BASSA SX PRUA	OKOUME' GREZZO	4	Dante

- 1 - L 1727.5 x H 124 x sp 10 mm
- 2 - L 1727.5 x H 40 x sp 6 mm
- 3 - L 1723 x H 339 x sp 10 mm
- 4 - L 824.5 x H 193 x sp 6 mm

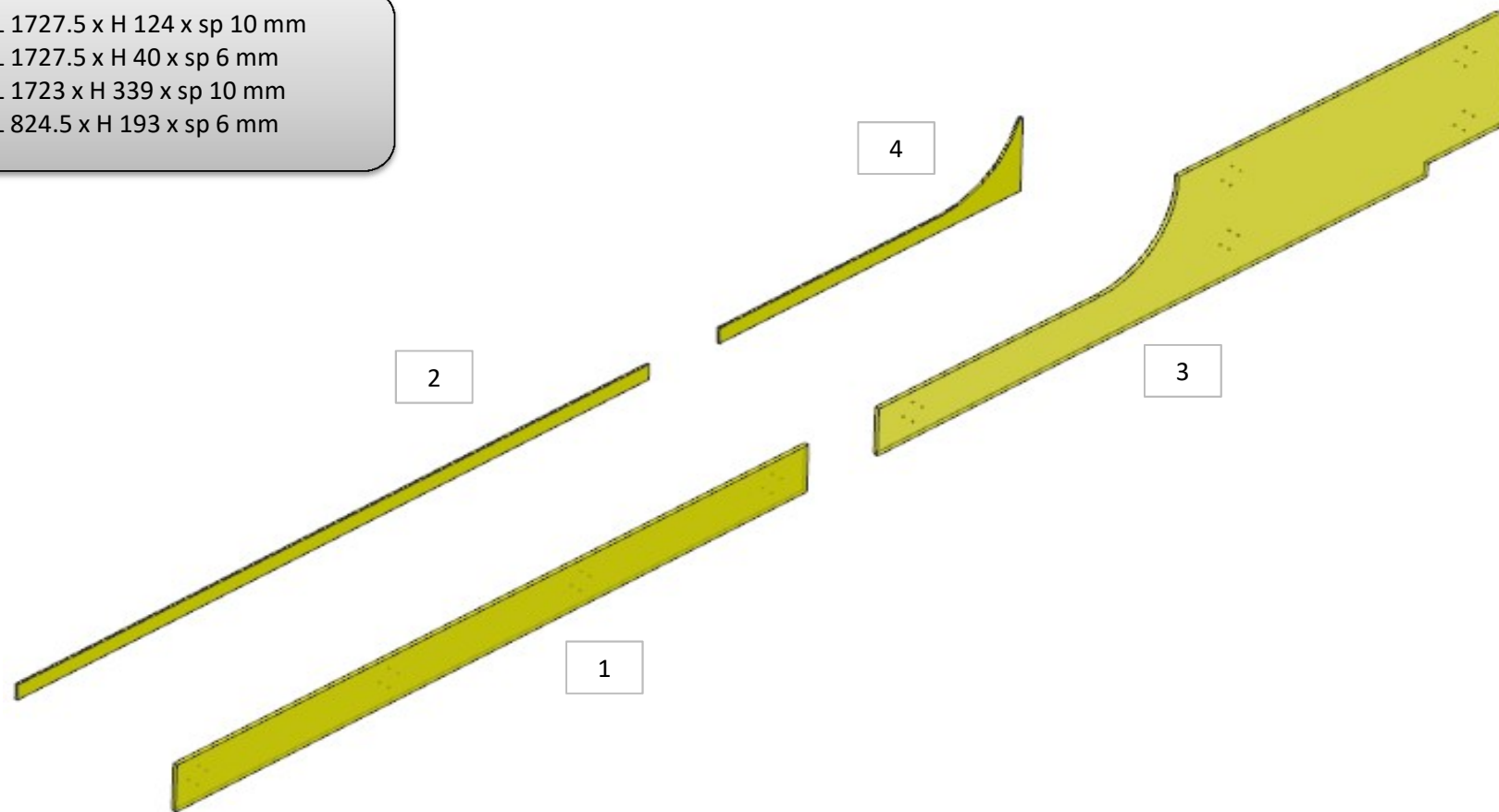

AZ68F

DA MAT. 216 REV. 25-05-2021

LOCALE	CODICE	DESCRIZIONE COMPONENTE	FINITURA	Q.TA	OPERATORE
SALONE	AZ68F-I01_SG01	CASSAPANCA SX	OKOUME' GREZZO	2	Dante

1 - svilup. 1445 x sp. 6 mm
2 - L 546 x H 260 x sp.23 mm

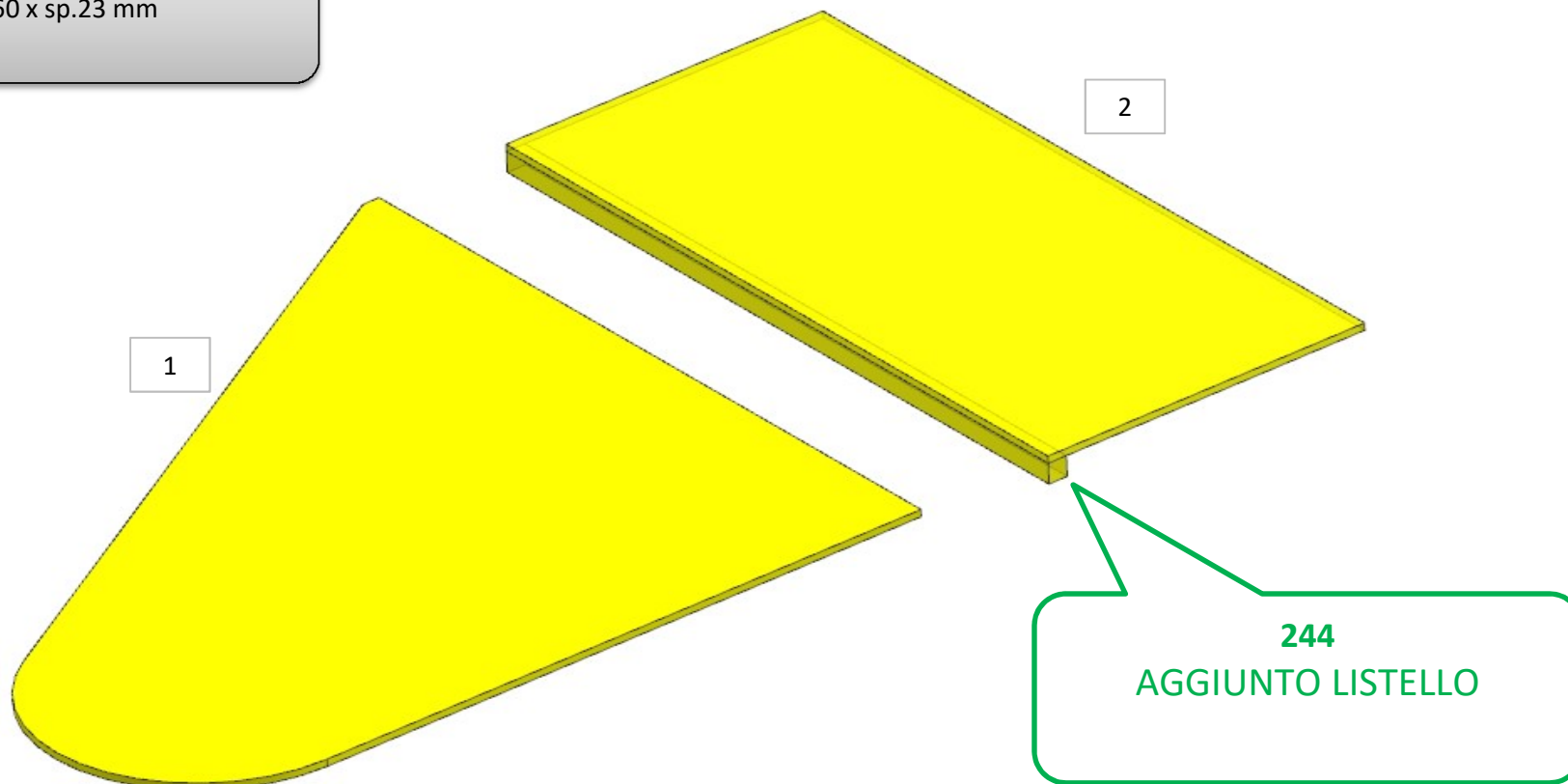

AZ68F

REV. 25-05-2021

LOCALE	CODICE	DESCRIZIONE COMPONENTE	FINITURA	Q.TA	OPERATORE
SALONE	AZ68F-I01_SI01	STRUTTURA MURATA BASSA DX	OKOUME' GREZZO	1	Dante

1 - L 3006 x H 152.5 x sp 15 mm

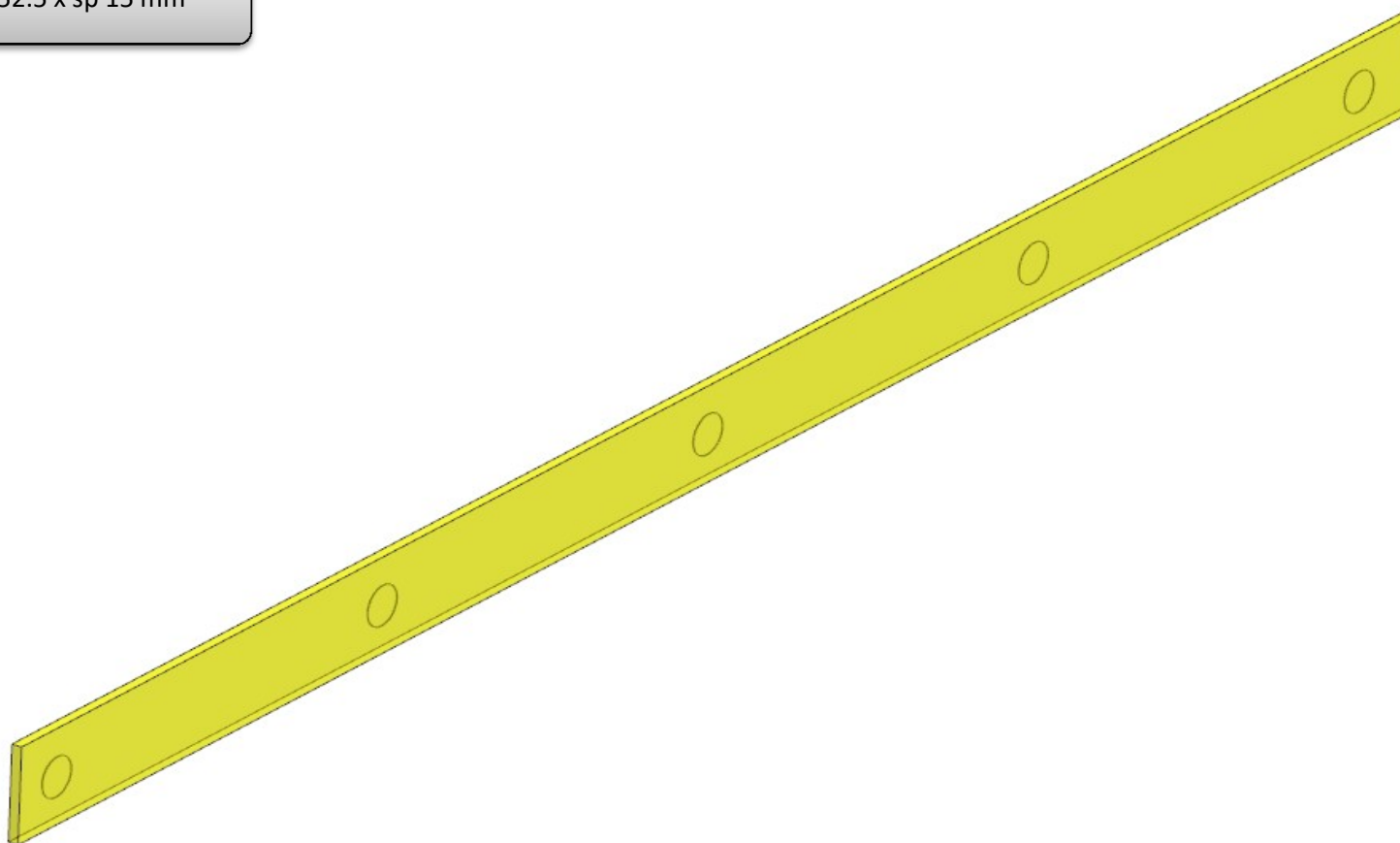

AZ68F

REV. 25-05-2021

LOCALE	CODICE	DESCRIZIONE COMPONENTE	FINITURA	Q.TA	OPERATORE
SALONE	AZ68F-I01_SL01	COLONNA PLENUM DX PRUA	OKOUME' GREZZO	1	Dante

1 - L 2430 x H 76 x sp 15 mm

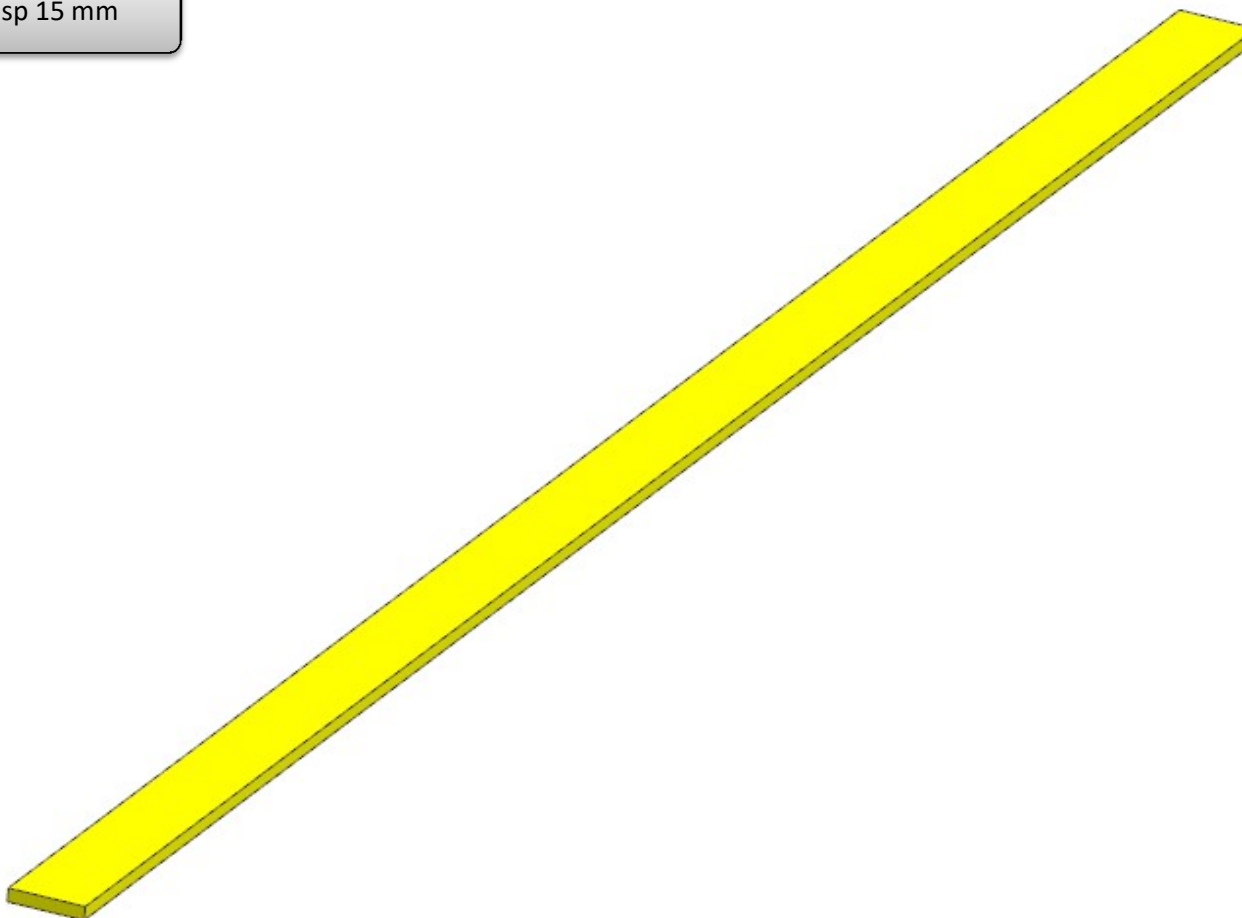

AZ68F

REV. 25-05-2021

LOCALE	CODICE	DESCRIZIONE COMPONENTE	FINITURA	Q.TA	OPERATORE
SALONE	AZ68F-I01_SP01	TAVOLO HI-LO OPT	OKOUME' GREZZO	4	Damiano

1/2/3/4 - L 287 x H 322 x pr. 92 mm

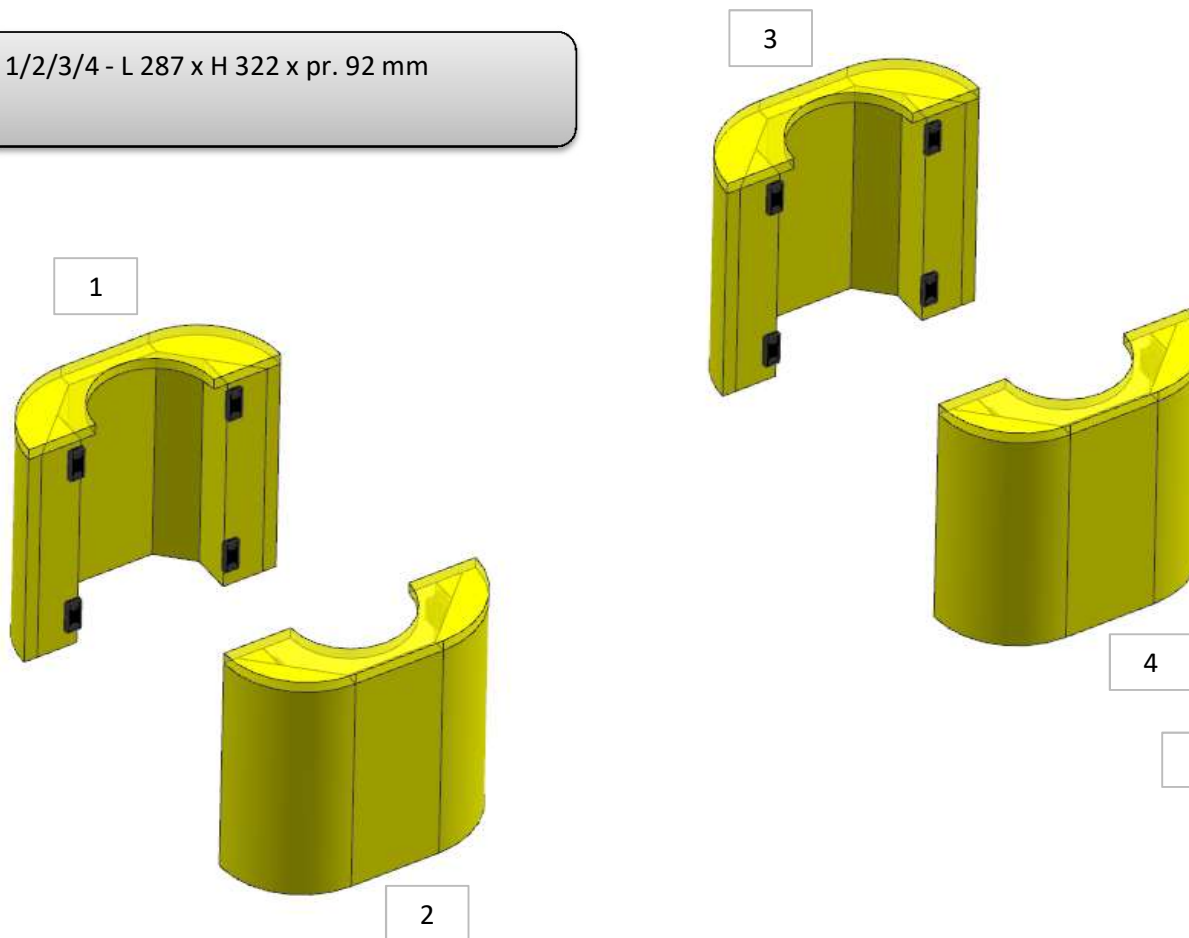

FERRAMENTA:

N° 12 - CERNIERA A BISCOTTO
N° 8 - CALAMITE M/F PER CASSETTI
SUGATSUNE

ELEMENTO DA MONTARE con:
R01_SP01
A01_SP01
e spedire con un unico imballo

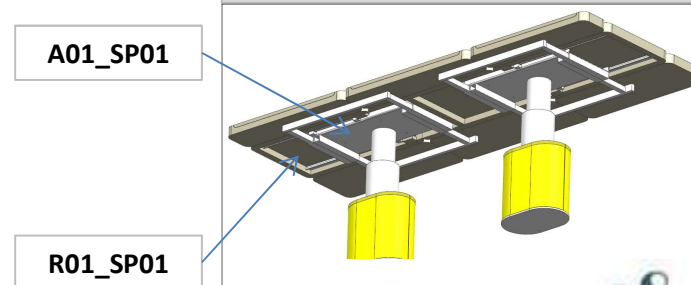

consonni&c

AZ68F

REV. 25-05-2021

LOCALE	CODICE	DESCRIZIONE COMPONENTE	FINITURA	Q.TA	OPERATORE
SALONE	AZ68F-I01_SQ01	TAVOLO STANDARD	OKOUME' GREZZO	4	Damiano

1/2/3/4 - L 287 x H 679 x pr. 92 mm

1

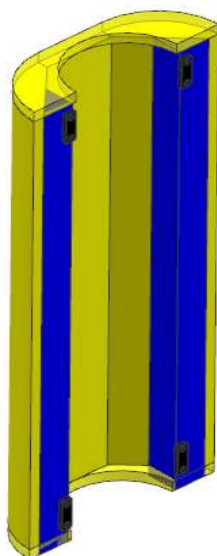

3

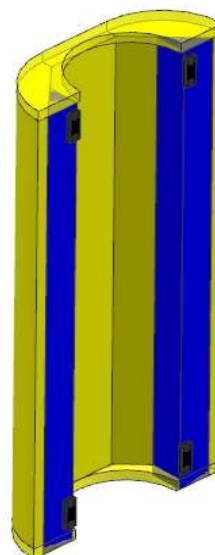

2



4



FERRAMENTA:

N° 12 - CALAMITE M/F PER CASSETTI
SUGATSUNE

1 - L 600 x H 237 x sp 44 mm

ELEMENTO DA MONTARE con:

I01_SQ01
A01_SQ01

e spedire con un unico imballo

A01_SQ01

R01_SQ01

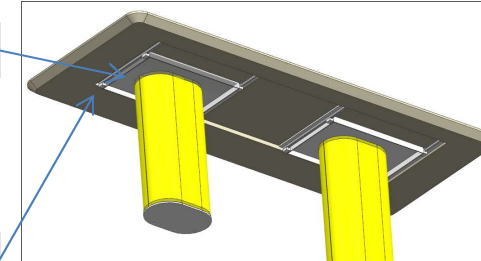

consonni&c