

AZ68F

DA MAT. 203 REV. 25-05-2021

LOCALE	CODICE	DESCRIZIONE COMPONENTE	FINITURA	Q.TA	OPERATORE
SALONE	AZ68F-A01_SB01	MURATA BASSA SX POPPA	RIMEX NERO	4	Damiano

- 1 - L 215 x H 853 x sp 1
- 2 - L 275 x H 152 x sp 1
- 3 - L 215 x H 248 x sp 1
- 4 - L 283 x H 533 x sp 1

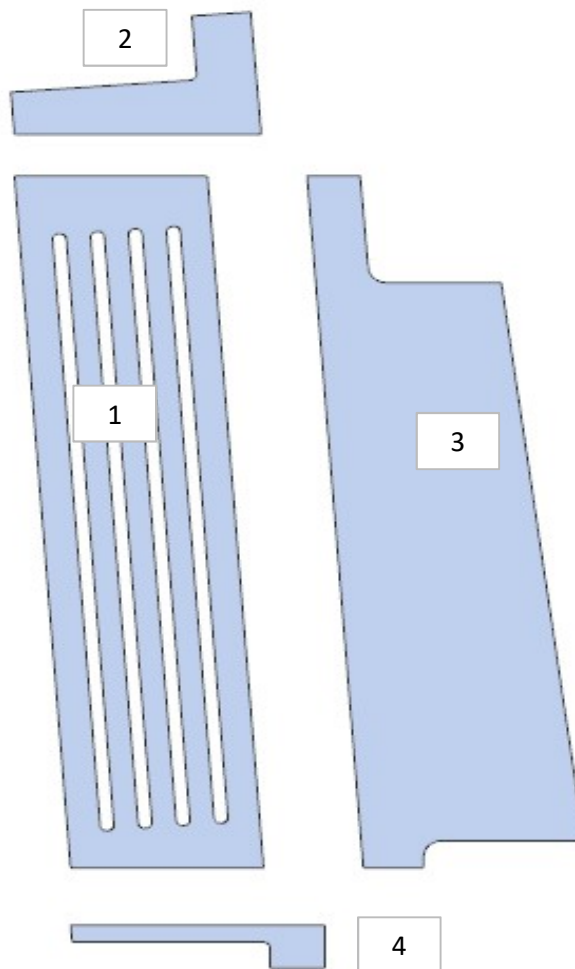

AZ68F

DA MAT. 203 REV. 25-05-2021

LOCALE	CODICE	DESCRIZIONE COMPONENTE	FINITURA	Q.TA	OPERATORE
SALONE	AZ68F-A01_SE01	MURATA BASSA SX PRUA	ACCIAIO	1	Damiano

1 - L 757 x H 320 x sp 2.5 mm

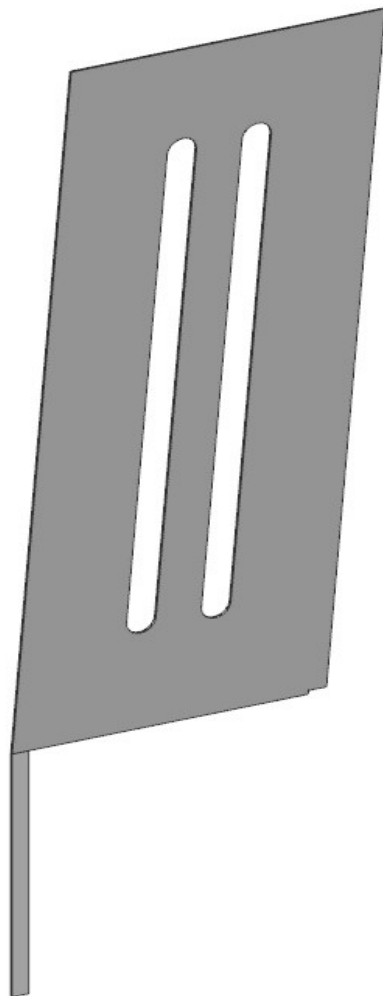

AZ68F

DA MAT. 201 REV. 25-05-2021

LOCALE	CODICE	DESCRIZIONE COMPONENTE	FINITURA	Q.TA	OPERATORE
SALONE	AZ68F-A01_SR01	COFFEE TABLE	ACCIAIO	1	Damiano

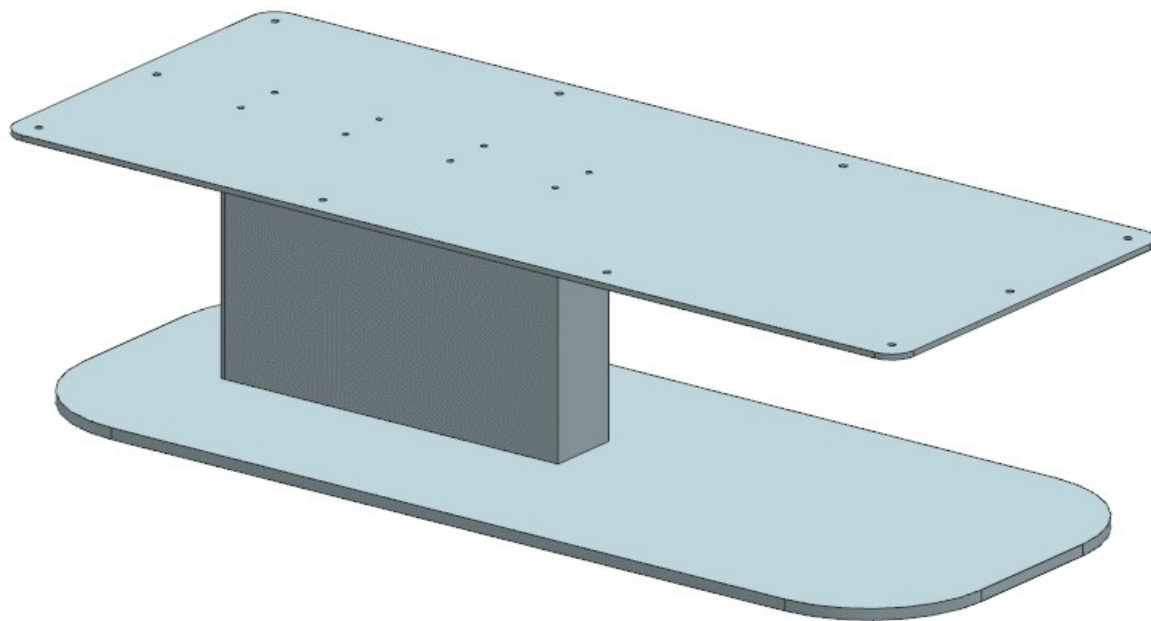

ELEMENTO DA MONTARE con:
L01_SR01
e spedire con un unico imballo

L01_SR01

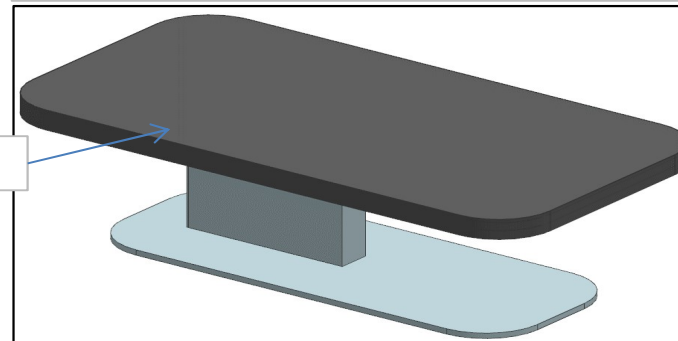

consonni&c

AZ68F

DA MAT. 201 REV. 25-05-2021

LOCALE	CODICE	DESCRIZIONE COMPONENTE	FINITURA	Q.TA	OPERATORE
SALONE	AZ68F-A01_SP01	TAVOLO HI-LO OPT	ACCIAIO	2	Damiano

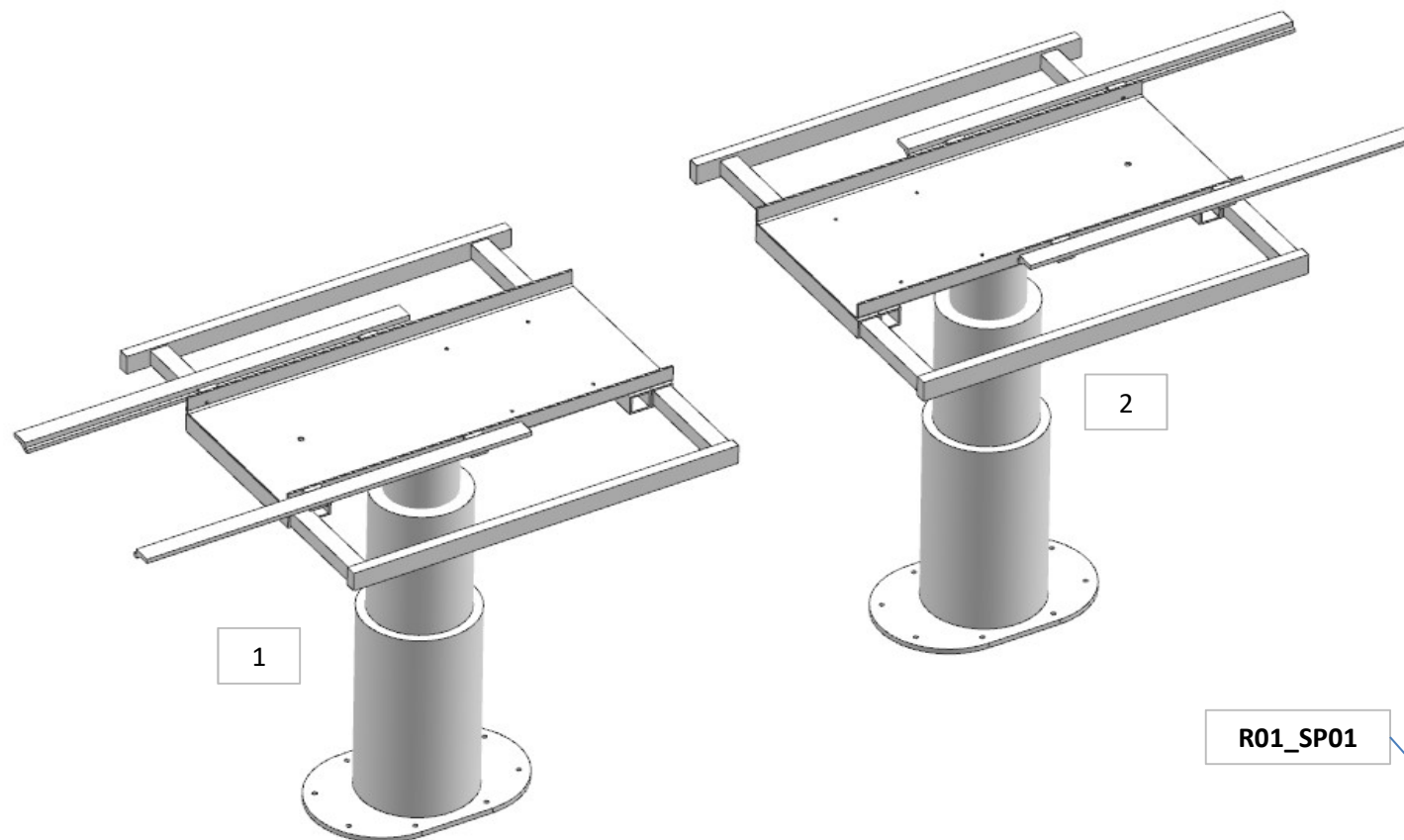

FERRAMENTA:

N° 12 - CERNIERA A BISCOTTO
N° 8 - CALAMITE M/F PER CASSETTI
SUGATSUNE

ELEMENTO DA MONTARE con:
R01_SP01
I01_SP01
e spedire con un unico imballo

R01_SP01

I01_SP01

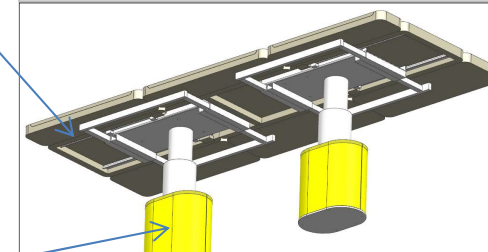

consonni&c

AZ68F

DA MAT. 201 REV. 25-05-2021

LOCALE	CODICE	DESCRIZIONE COMPONENTE	FINITURA	Q.TA	OPERATORE
SALONE	AZ68F-A01_SQ01	TAVOLO STANDARD	ACCIAIO	2	Damiano

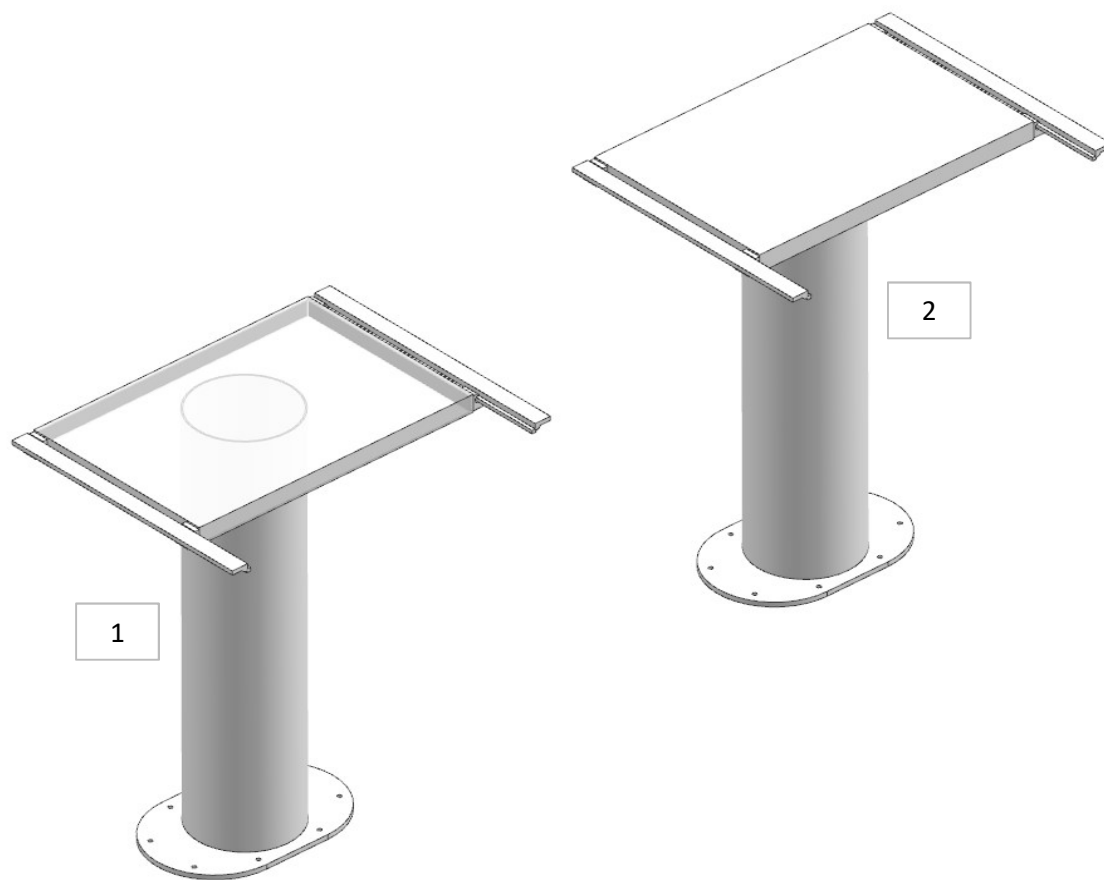

FERRAMENTA:

N° 12 - CALAMITE M/F PER CASSETTI
SUGATSUNE

ELEMENTO DA MONTARE con:
I01_SQ01
R01_SQ01
e spedire con un unico imballo

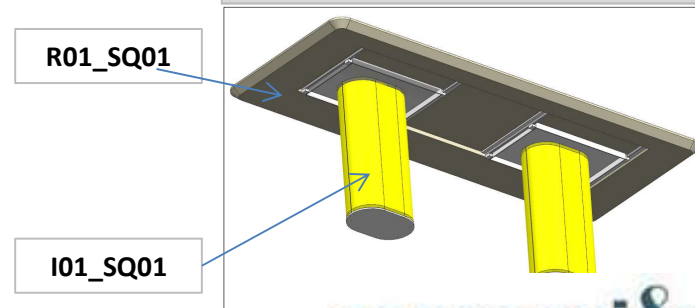

consonni&c