

# AZ68F

DA MAT. 233 REV. 29-04-2024

LOCALE	CODICE	DESCRIZIONE COMPONENTE	FINITURA	Q.TA	OPERATORE
SALONE A POPPA	AZ68F-R01_SSA01	PARETE DIVISORIA LATO POPPA	LASTRA CHIARA	5	Damiano

- 1 - L 712 x H 1151 x sp 16 mm
- 2 - L 383 x H 554 x sp 16 mm
- 3 - L 625 x H 1710 x sp 16 mm
- 4 - L 489 x H 275 x sp 16 mm
- 5 - L 321 x H 276 x sp 16 mm

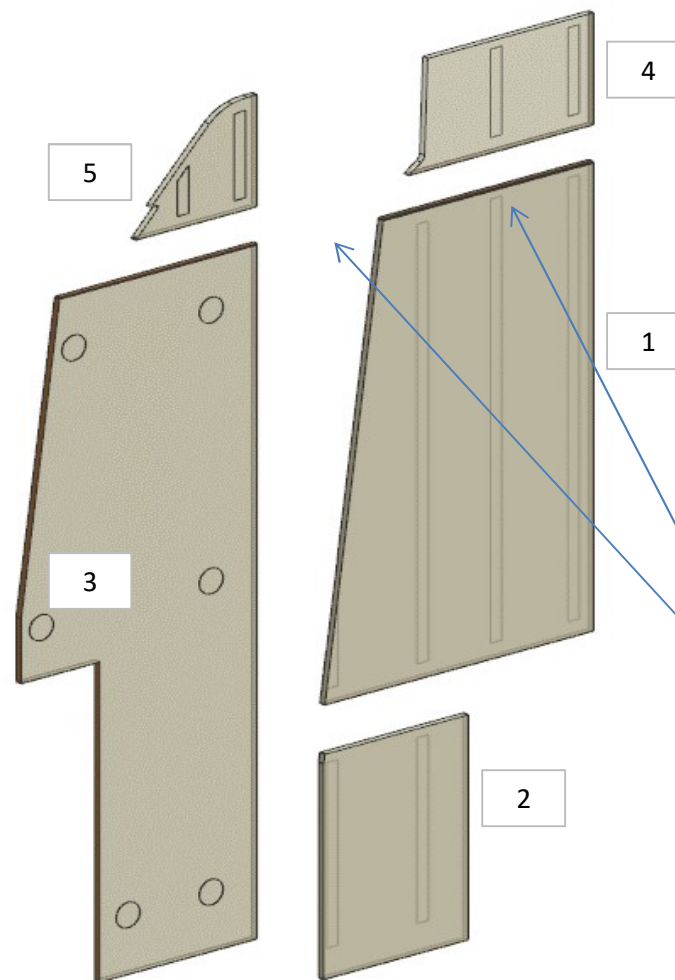

MODIFICATE  
MISURE PZ. 1 E 2  
VERIFICARE



# AZ68F

DA MAT. 233 REV. 29-04-2024

LOCALE	CODICE	DESCRIZIONE COMPONENTE	FINITURA	Q.TA	OPERATORE
SALONE A POPPA	AZ68F-R01_SSB01	LANTERNA DIVISORIA PRUA	LASTRA CHIARA	6	Damiano

- 1 - L.67 x H 1953 x 86
- 2 - L.40 x H 1953 x sp 25
- 3 - L.764,5 x H 652 x sp 16
- 4 - N° 25 LISTELLI =  
L.65 x H 1953 x sp 15
- 5 - L.759 x H 91 x sp 16
- 6 - L.53 x H 542 x sp 16

**AGGIUNTI PZ.**  
**5 e 6**

**FERRAMENTA:**

N° 75 - BUSSOLA ZAMA 6MA

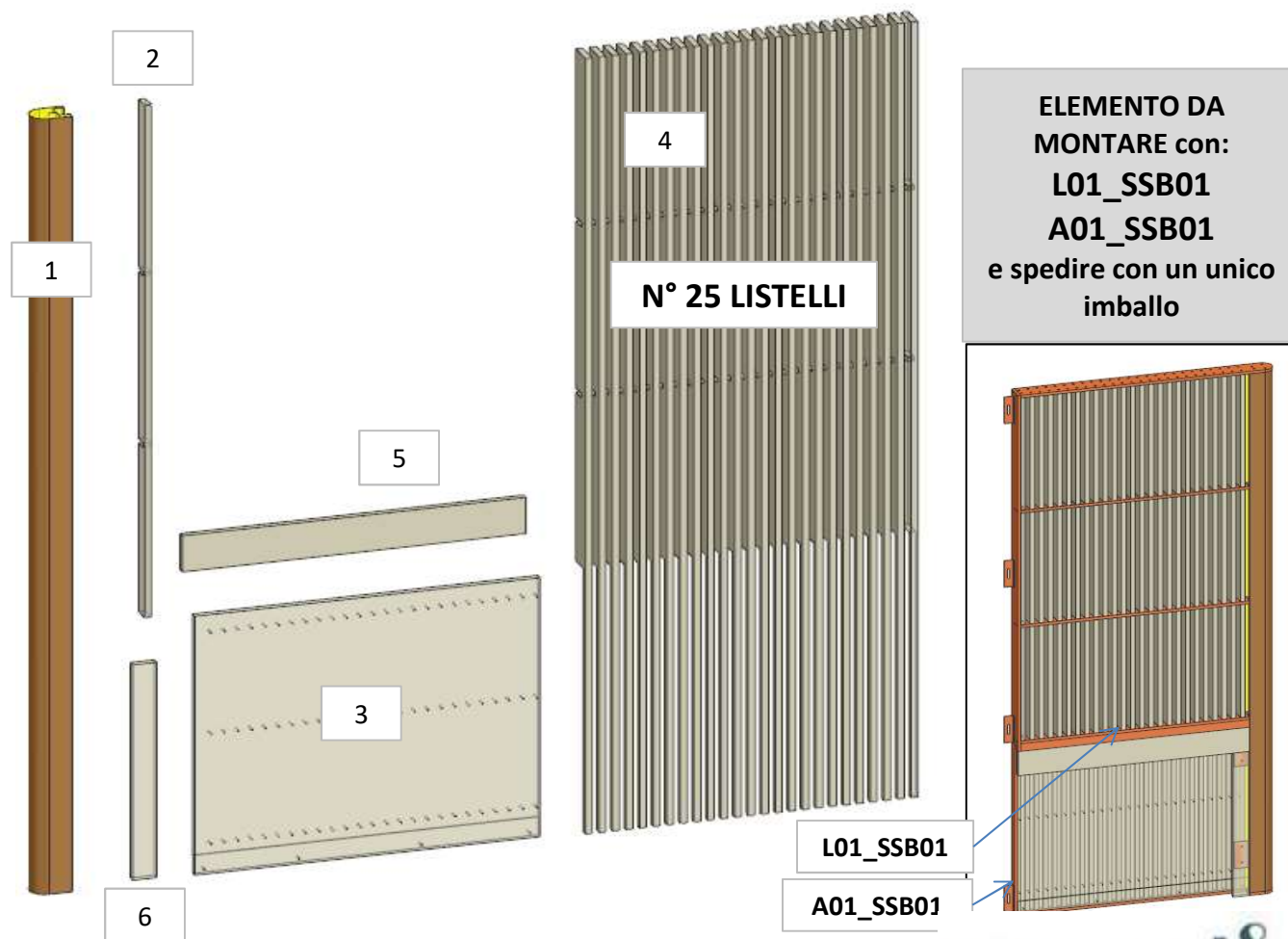

**ELEMENTO DA MONTARE con:**  
**L01\_SSB01**  
**A01\_SSB01**  
e spedire con un unico imballo

# AZ68F

DA MAT. 265 REV. 29-04-2024

LOCALE	CODICE	DESCRIZIONE COMPONENTE	FINITURA	Q.TA	OPERATORE
SALONE A POPPA	AZ68F-R01_SSC01	MURATA BASSA DX PRUA	LASTRA CHIARA	9	Damiano

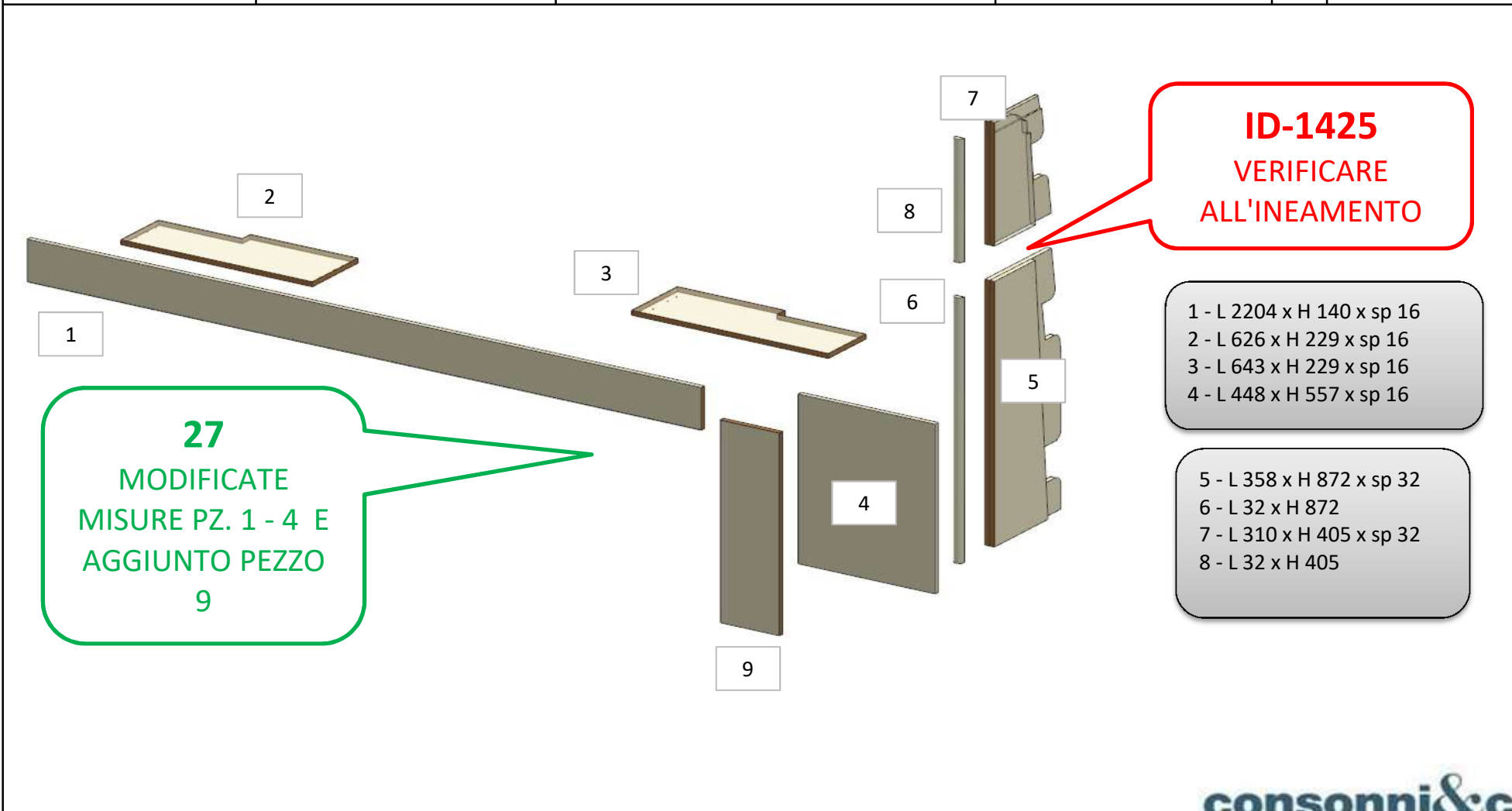

# AZ68F

VER.2024 REV. 29-04-2024

LOCALE	CODICE	DESCRIZIONE COMPONENTE	FINITURA	Q.TA	OPERATORE
SALONE A POPPA	AZ68F-R02_SSC01	MURATA BASSA DX PRUA	LASTRA TEAK	3	Damiano

- 1 - L. 2655 x sp 32 x H.30
- 2 - L. 327 x sp 6 x H.33
- 3 - L. 285 x sp 6 x H.33

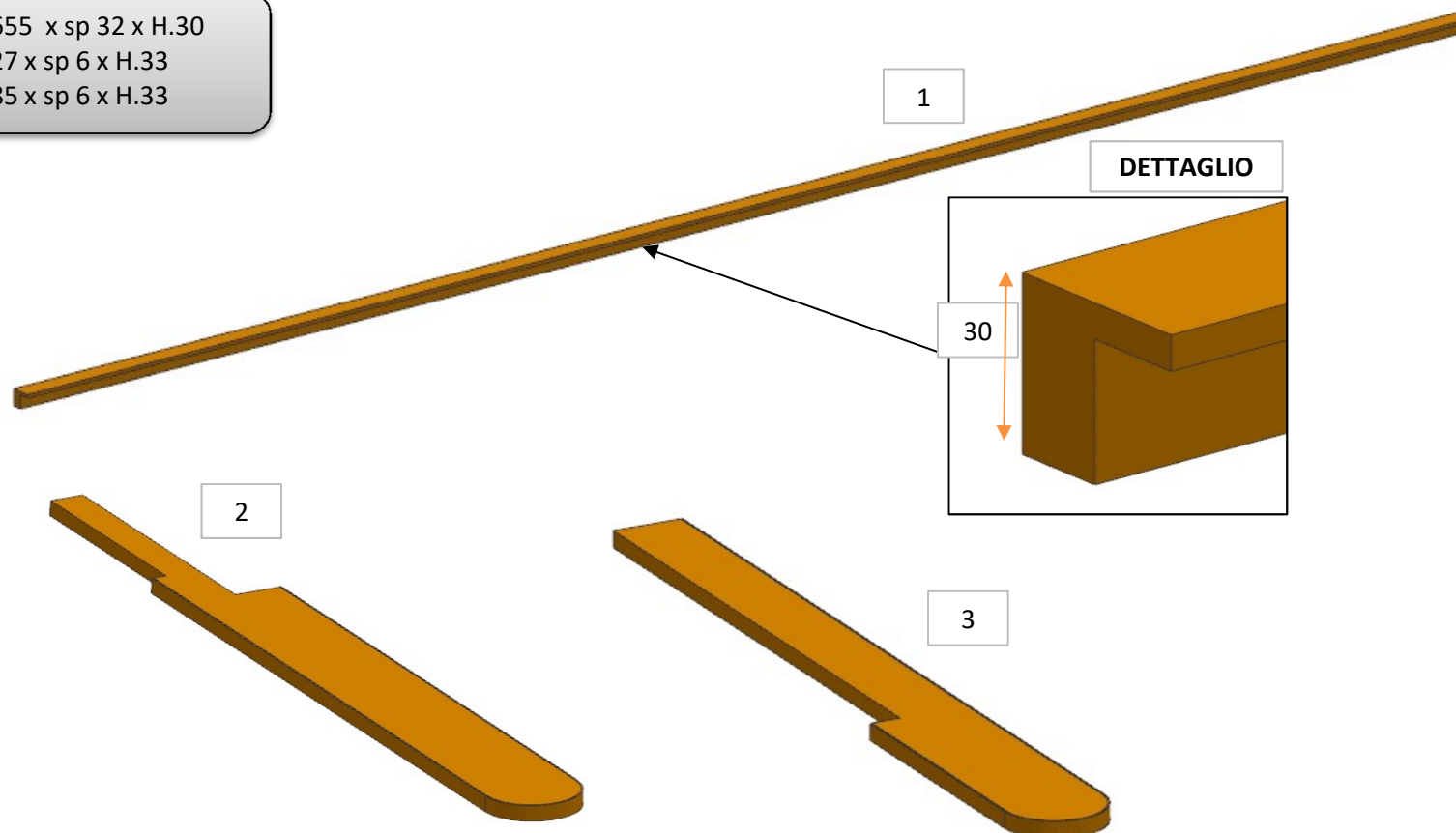

# AZ68F

DA MAT.229

REV. 29-04-2024

LOCALE	CODICE	DESCRIZIONE COMPONENTE	FINITURA	Q.TA	OPERATORE
SALONE A POPPA	AZ68F-R01_SSD01	MURATA BASSA TV	LASTRA CHIARA	2	Damiano

- 1 - L 1380 x H 226 x sp 16mm
- 2 - L 2091x H 49 x sp 16mm
- 3 - L 2091 x H 115 x sp 16mm

**VERIFICARE  
PRESENZA  
BORDO**

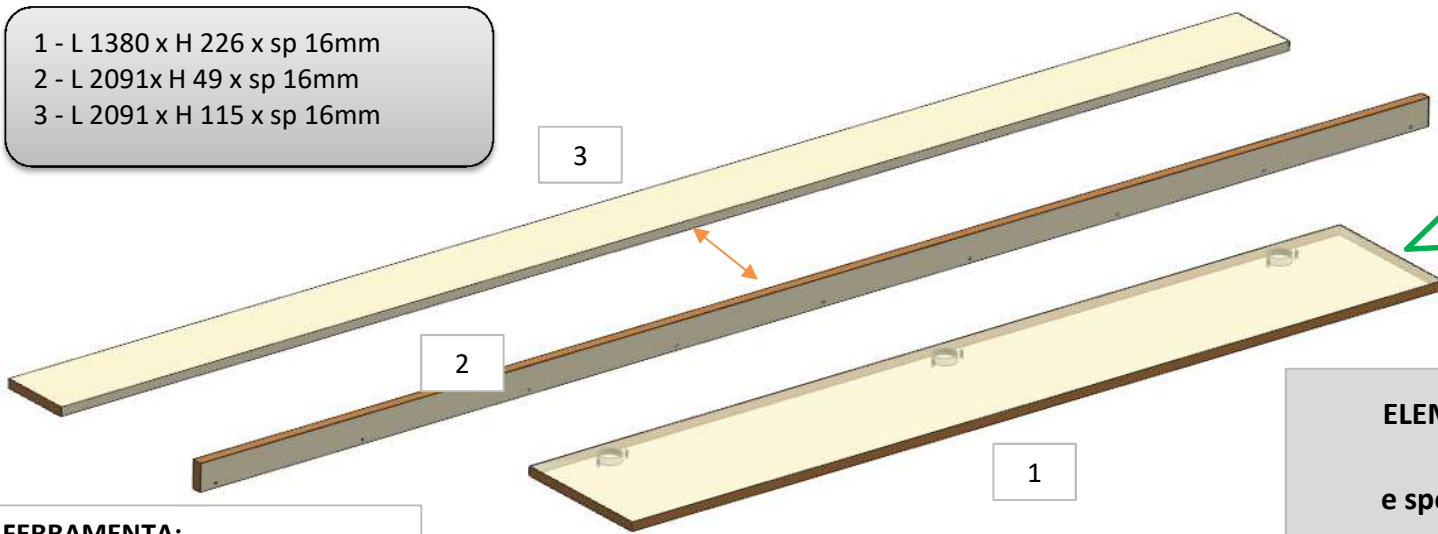

**ELEMENTO N.1 DA MONTARE:  
SSD01  
e spedire con un unico imballo**

- FERRAMENTA:**
- N° 3 - CERNIERA PIANA SENZA MOLLA
  - N° 3 - Basetta H6
  - N° 12 - ANKOR BORGHI
  - N° 2 - GOMMINO PARACOLPI
  - N° 6 - BUSSOLA ZAMA 6MA

**ELEMENTI N.2 E 3 DA MONTARE:  
MG\_SSD01  
e spedire con un unico imballo**

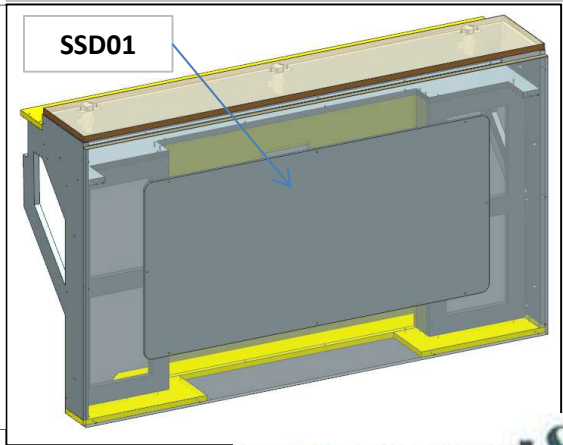

# AZ68F

DA MAT. 203 REV. 29-04-2024

LOCALE	CODICE	DESCRIZIONE COMPONENTE	FINITURA	Q.TA	OPERATORE
SALONE A POPPA	AZ68F-R01_SSE01	CASSAPANCA DX	LASTRA CHIARA	3	Damiano

1 - 3 - L.598 x H 235 x sp 16  
2 - SVILUPPO: L.706 x H 235 x sp 16

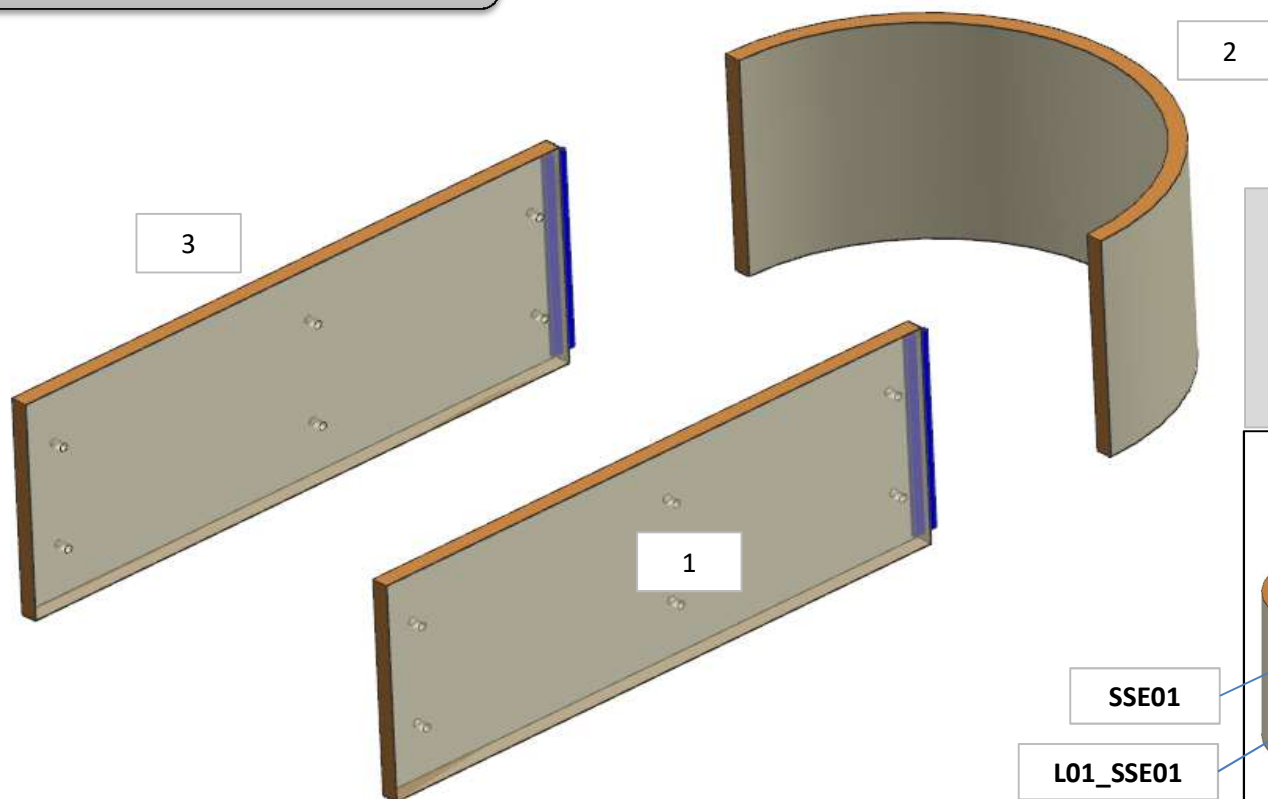

**ELEMENTO DA MONTARE:  
SSE01  
L01-SSE01  
e spedire con un unico imballo**

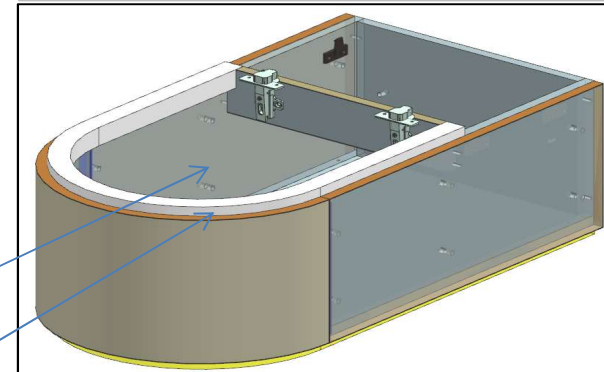

# AZ68F

DA MAT.212 REV. 29-04-2024

LOCALE	CODICE	DESCRIZIONE COMPONENTE	FINITURA	Q.TA	OPERATORE
SALONE A POPPA	AZ68F-R01_SSF01	COLONNA PLENUM DX PRUA	LASTRA CHIARA	3	Damiano

- 1 - L 391 x H 874 x sp 32mm
- 2 - L.3006 x H.310 x sp 16mm
- 3 - dia 32 x H 874mm

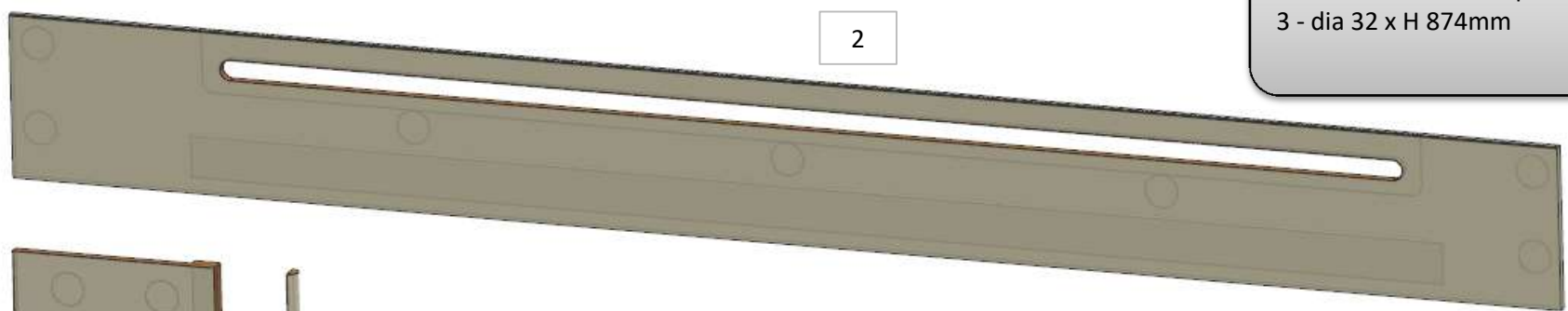

2

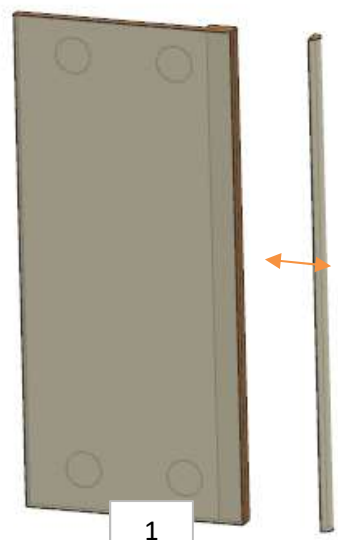

1



3

ELEMENTI N.1 e 3 DA MONTARE e spedire con un unico imballo

ELEMENTO N.1 DA MONTARE: X01-SSF01 e spedire con un unico imballo

MG\_SSF01

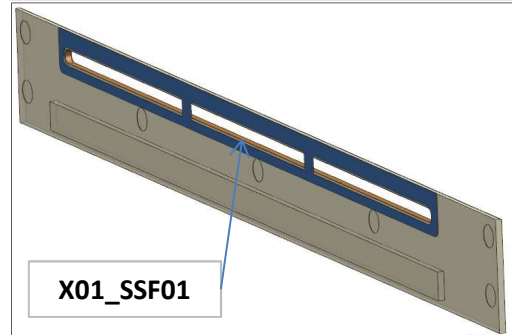
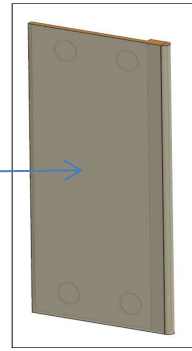

X01\_SSF01

# AZ68F

VER.2024 REV. 29-04-2024

LOCALE	CODICE	DESCRIZIONE COMPONENTE	FINITURA	Q.TA	OPERATORE
SALONE A POPPA	AZ68F-R02_SSF01	COLONNA PLENUM DX PRUA	LASTRA TEAK	1	Damiano

1 - L 3007 x H 30 x sp 33



DETTAGLIO

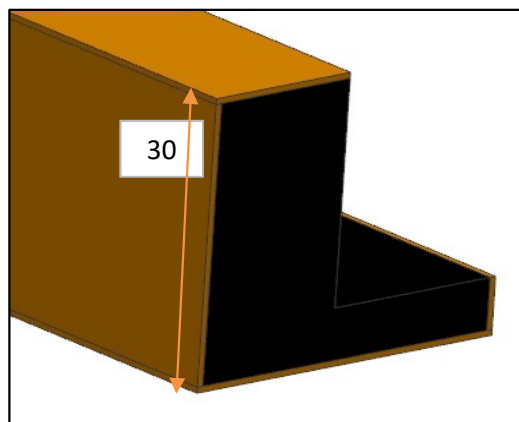

ELEMENTO DA MONTARE:  
R01-SSF01  
X01-SSF01  
e spedire con un unico imballo

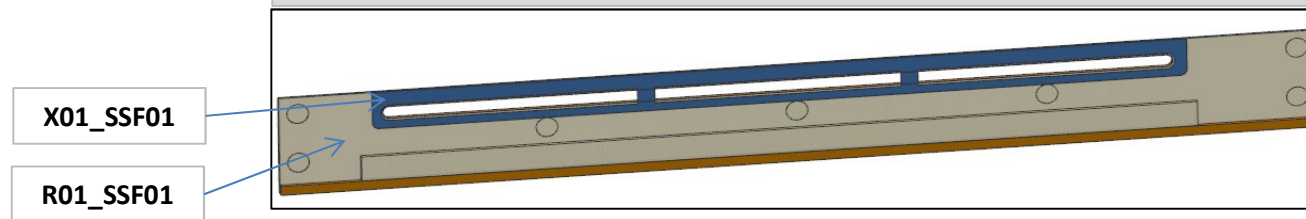

# AZ68F

REV. 29-04-2024

LOCALE	CODICE	DESCRIZIONE COMPONENTE	FINITURA	Q.TA	OPERATORE
SALONE A POPPA	AZ68F-R01_SSG01	STRUTTURA MURATA BASSA DX	LASTRA CHIARA	1	Damiano

1 - L..84 x H.2429 x sp 15

**34 (step1)**  
MODIFICATA  
SAGOMA GRADINO

# AZ68F

VER.2024 REV. 29-04-2024

LOCALE	CODICE	DESCRIZIONE COMPONENTE	FINITURA	Q.TA	OPERATORE
SALONE A POPPA	AZ68F-R02_SSG01	STRUTTURA MURATA BASSA DX	LASTRA TEAK	1	Damiano

1 - L 3007 x 33 x H 30

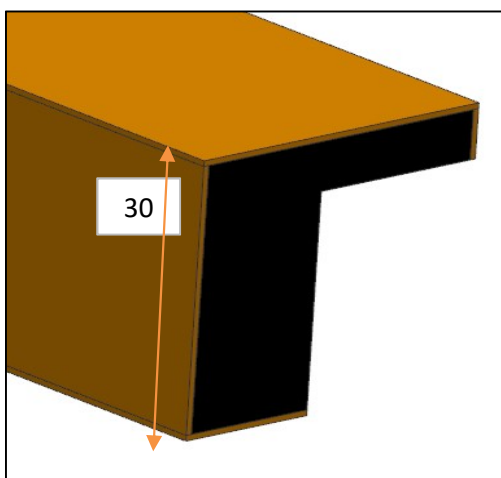
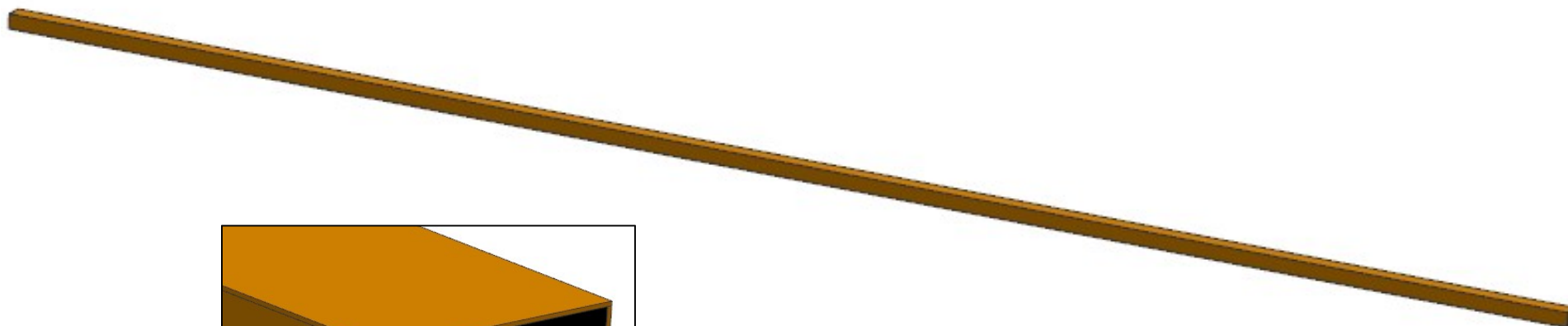

DETTAGLIO

# AZ68F

DA MAT.212 REV. 29-04-2024

LOCALE	CODICE	DESCRIZIONE COMPONENTE	FINITURA	Q.TA	OPERATORE
SALONE A POPPA	AZ68F-R01_SSH01	COLONNA POPPA MURATA DX	LASTRA CHIARA	3	Damiano

- 1 - L 285 x H 874 x sp 32mm
- 2 - L 120 x H 2025x 141mm
- 3 - dia. 32mm x H 874mm

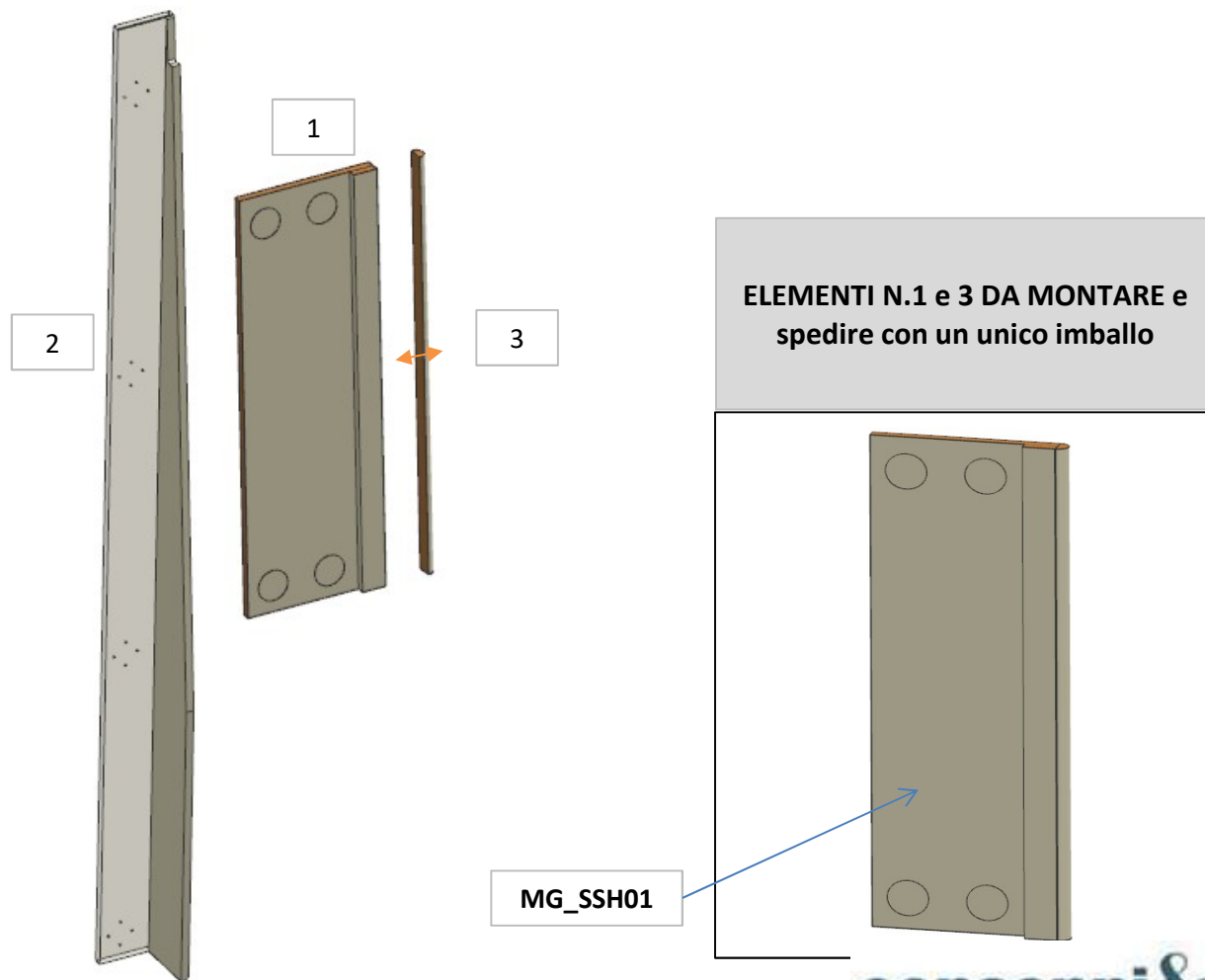

# AZ68F

DA MAT.212 REV. 29-04-2024

LOCALE	CODICE	DESCRIZIONE COMPONENTE	FINITURA	Q.TA	OPERATORE
SALONE A POPPA	AZ68F-R01_SSI01	GRADINO ALTO	LASTRA CHIARA	2	Damiano

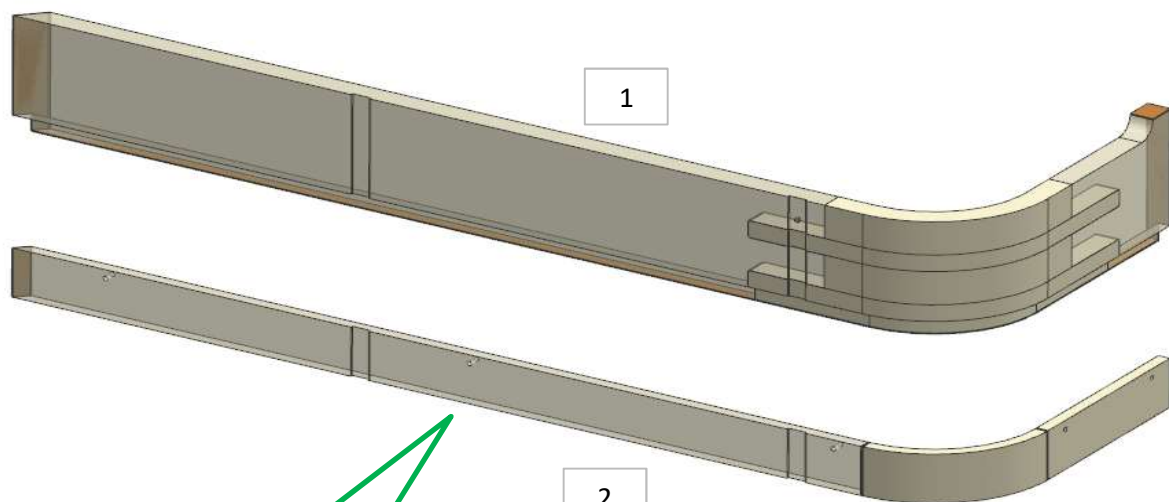

**34 (step1)**  
MODIFICATA  
SAGOMA GRADINO

- 1 - L 1020 x H121 x sp 20mm
- 2 - L.1020 x H.44 x sp 10mm

**ELEMENTO DA MONTARE:  
SSI01**  
e spedire con un unico imballo

SSI01

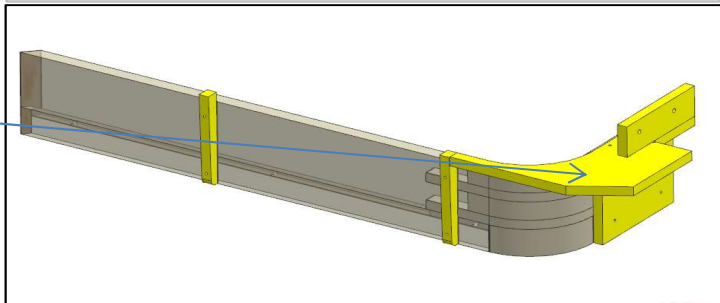

# AZ68F

DA MAT. 212 REV. 29-04-2024

LOCALE	CODICE	DESCRIZIONE COMPONENTE	FINITURA	Q.TA	OPERATORE
SALONE A POPPA	AZ68F-R02_SSI01	GRADINO ALTO	LASTRA TEAK	1	Damiano

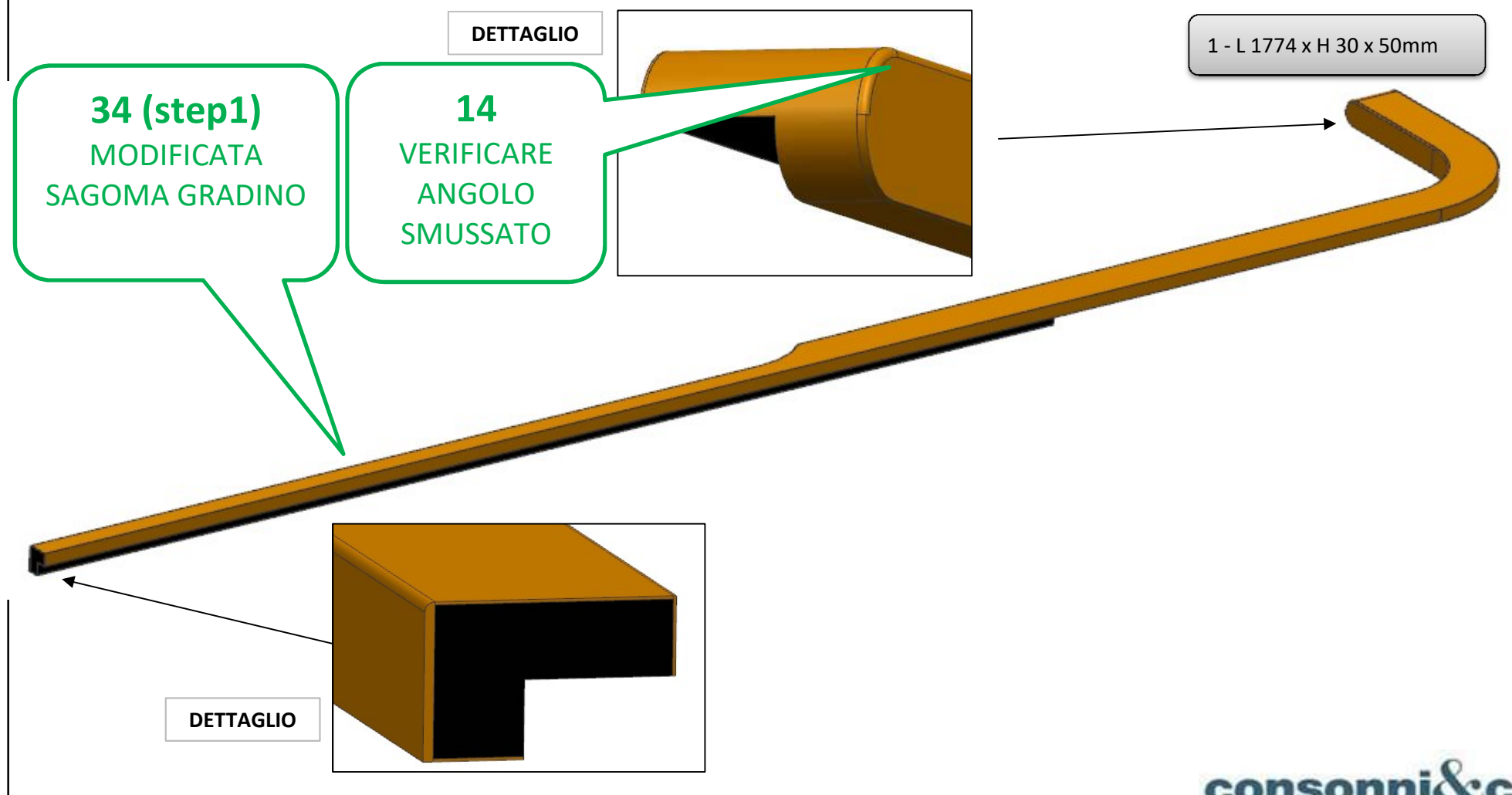

# AZ68F

DA MAT. 265 REV. 29-04-2024

LOCALE	CODICE	DESCRIZIONE COMPONENTE	FINITURA	Q.TA	OPERATORE
SALONE A POPPA	AZ68F-R01_SSM01	MURATA BASSA SX PRUA	LASTRA CHIARA	3	Damiano

- 1 - L.1731 x H 117,5 x sp 16
- 2 - L. 828 x H 117,5 x sp 16
- 3 - SVILUPPO L.900 x H 164 x sp 16

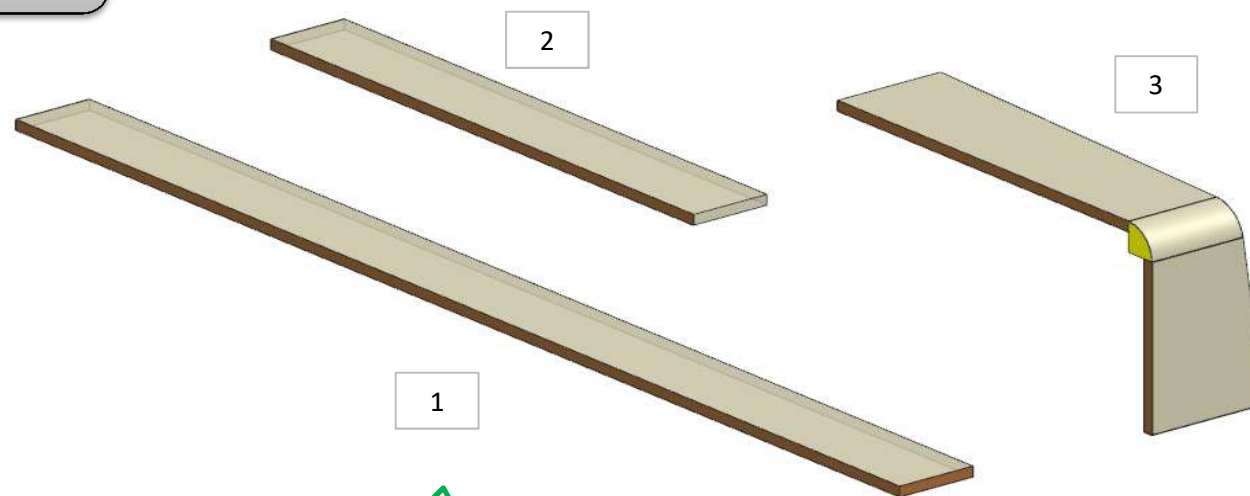

ALLARGATOI FASCE-  
CONTROLLARE  
MISURE

# AZ68F

DA MAT. 265 REV. 29-04-2024

LOCALE	CODICE	DESCRIZIONE COMPONENTE	FINITURA	Q.TA	OPERATORE
SALONE A POPPA	AZ68F-R02_SSM01	MURATA BASSA SX PRUA	LASTRA TEAK	3	Damiano

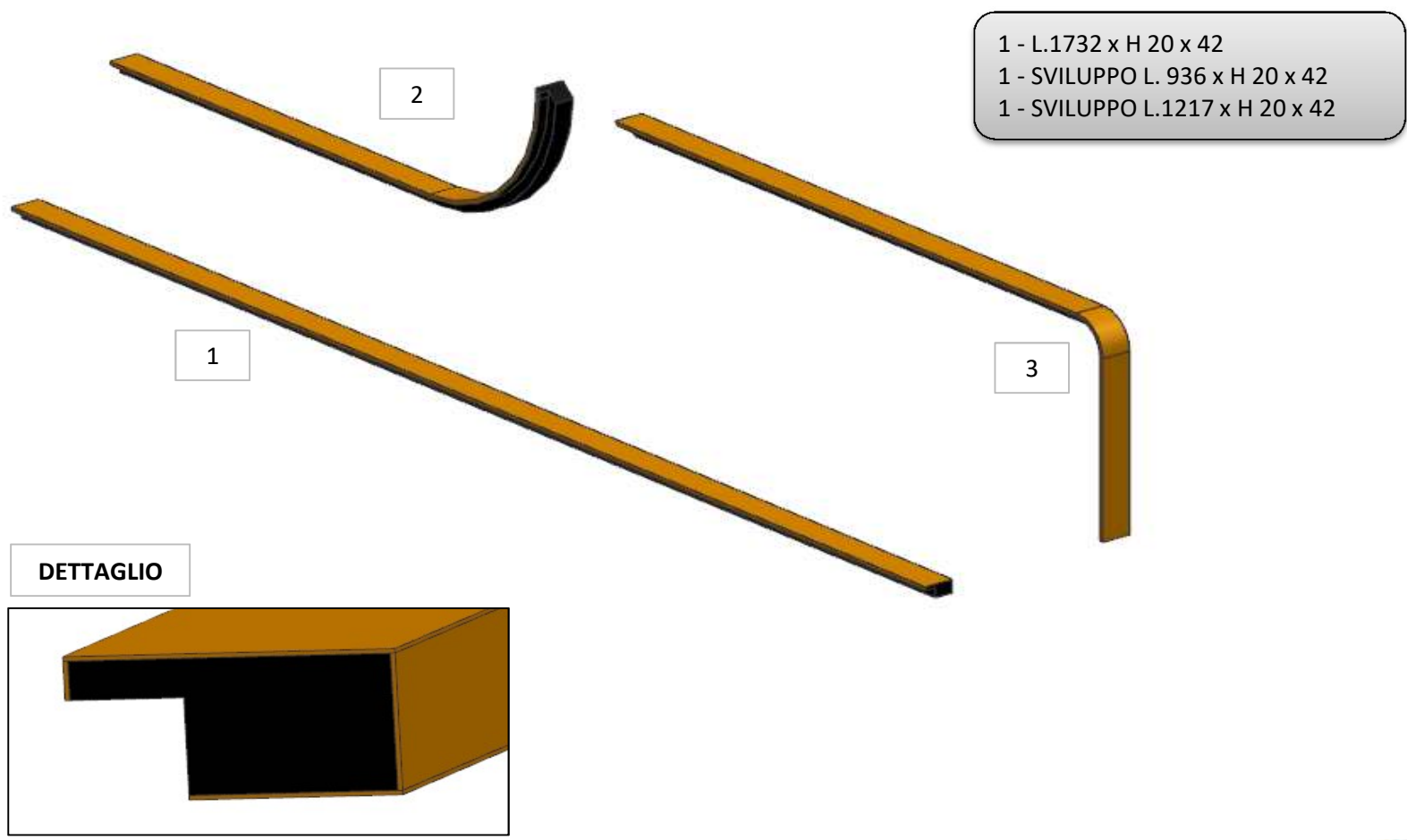

# AZ68F

DA MAT. 203 REV. 29-04-2024

LOCALE	CODICE	DESCRIZIONE COMPONENTE	FINITURA	Q.TA	OPERATORE
SALONE A POPPA	AZ66F-R01_SSO01	TAVOLO	LASTRA CHIARA	4	Damiano

- 1 - L.900 x H 701 x sp 30
- 2 - L.900 x H 701 x sp 30
- 3 - 4 - L.830 x H 33 x 90

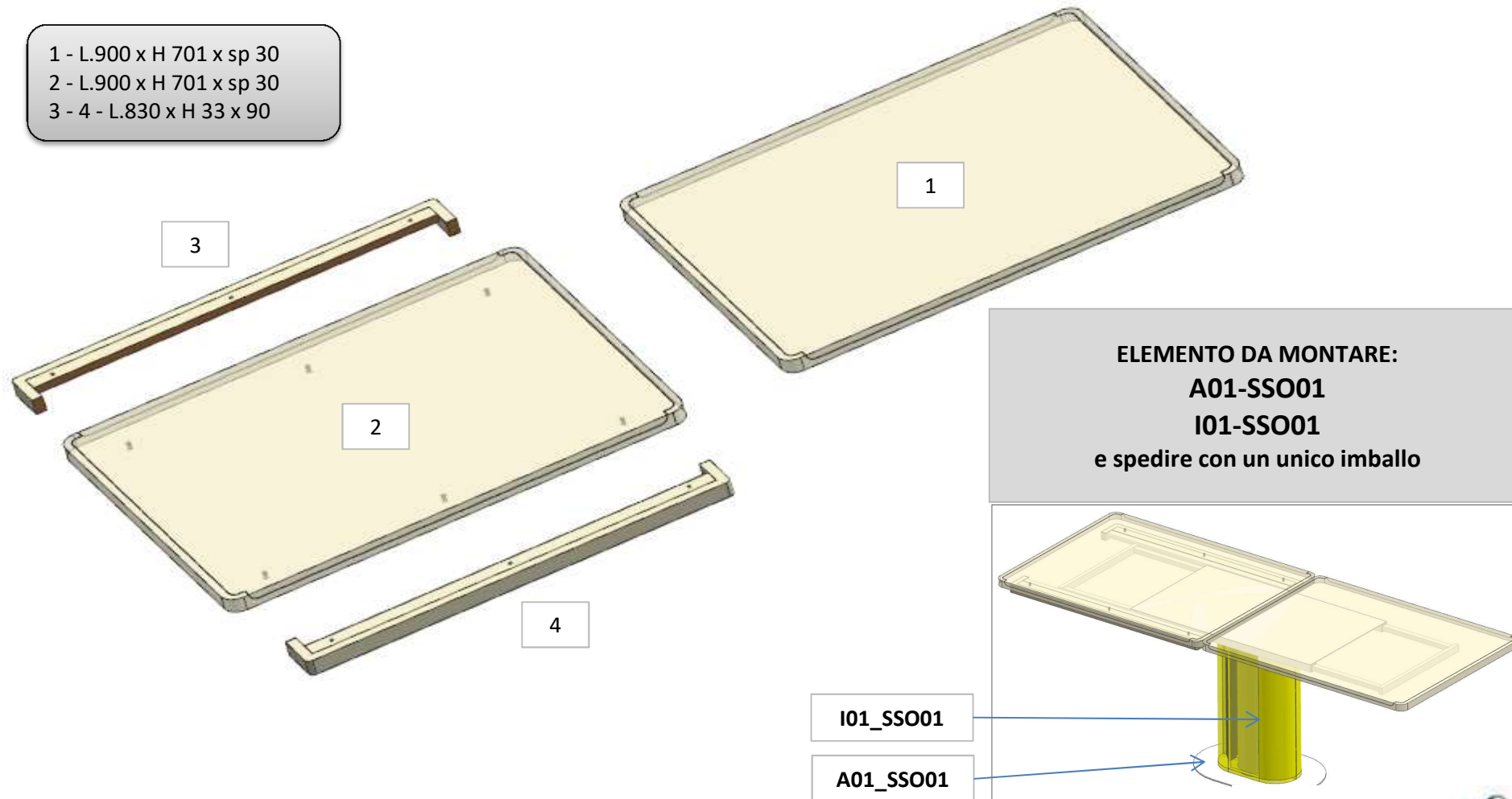

consonni&c

# AZ68F

DA MAT. 203 REV. 29-04-2024

LOCALE	CODICE	DESCRIZIONE COMPONENTE	FINITURA	Q.TA	OPERATORE
SALONE A POPPA	AZ66F-R01_SSP01	COMODINO DIVANO POPPA	LASTRA TEAK	5	Damiano

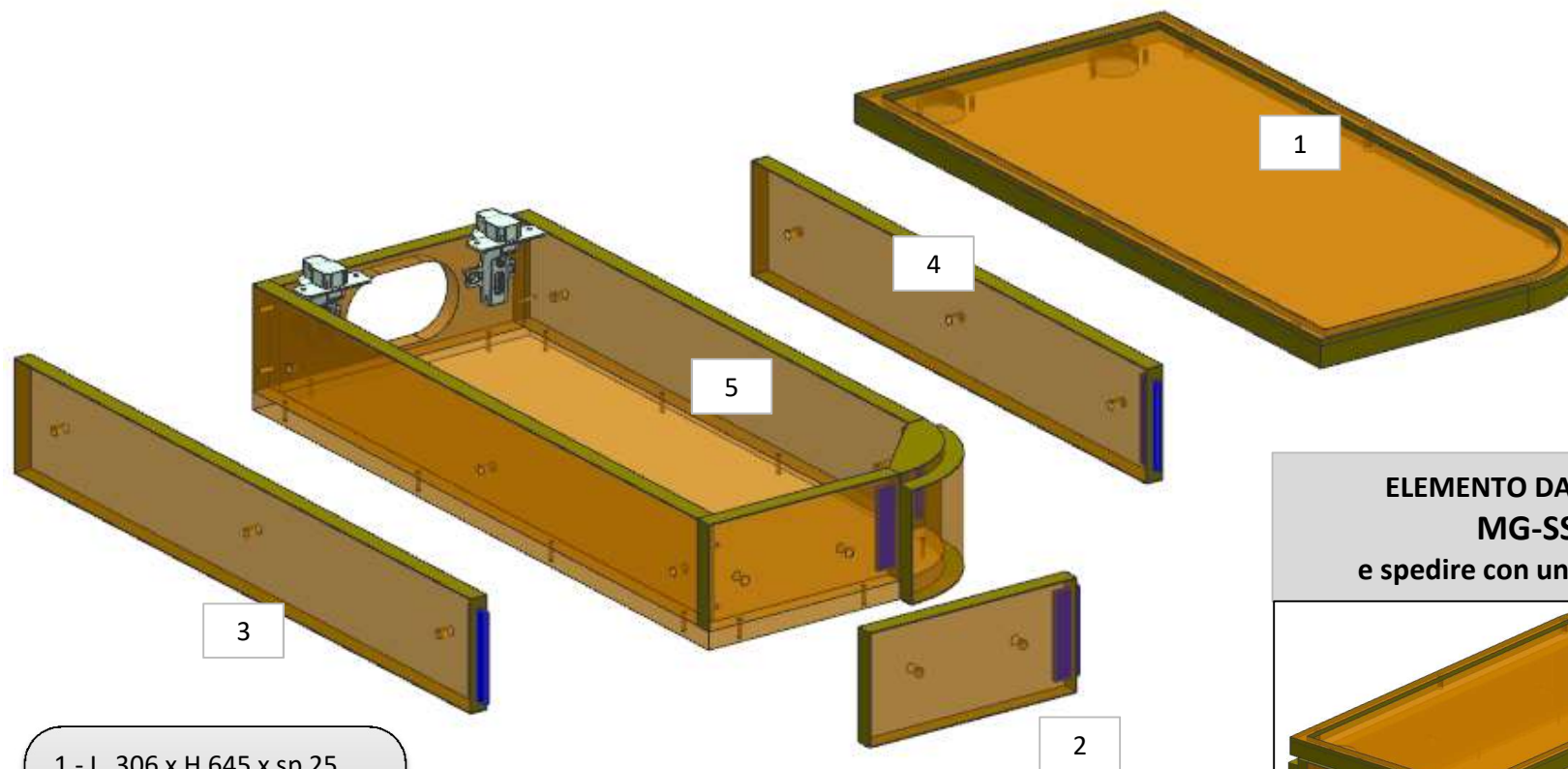

**ELEMENTO DA MONTARE:  
MG-SSP01  
e spedire con un unico imballo**

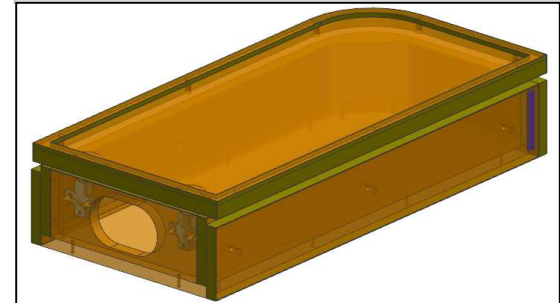

- 1 - L. 306 x H 645 x sp 25
- 2 - L. 205 x H 100 x sp 16
- 3 - L. 634 x H 100 x sp 16
- 4 - L. 549 x H 100 x sp 25
- 5 - L. 274x H 109 x 634

# AZ68F

DA MAT. 203 REV. 29-04-2024

LOCALE	CODICE	DESCRIZIONE COMPONENTE	FINITURA	Q.TA	OPERATORE
SALONE A POPPA	AZ66F-R01_SSQ01	DIVANO PRUA	LASTRA CHIARA	4	Damiano

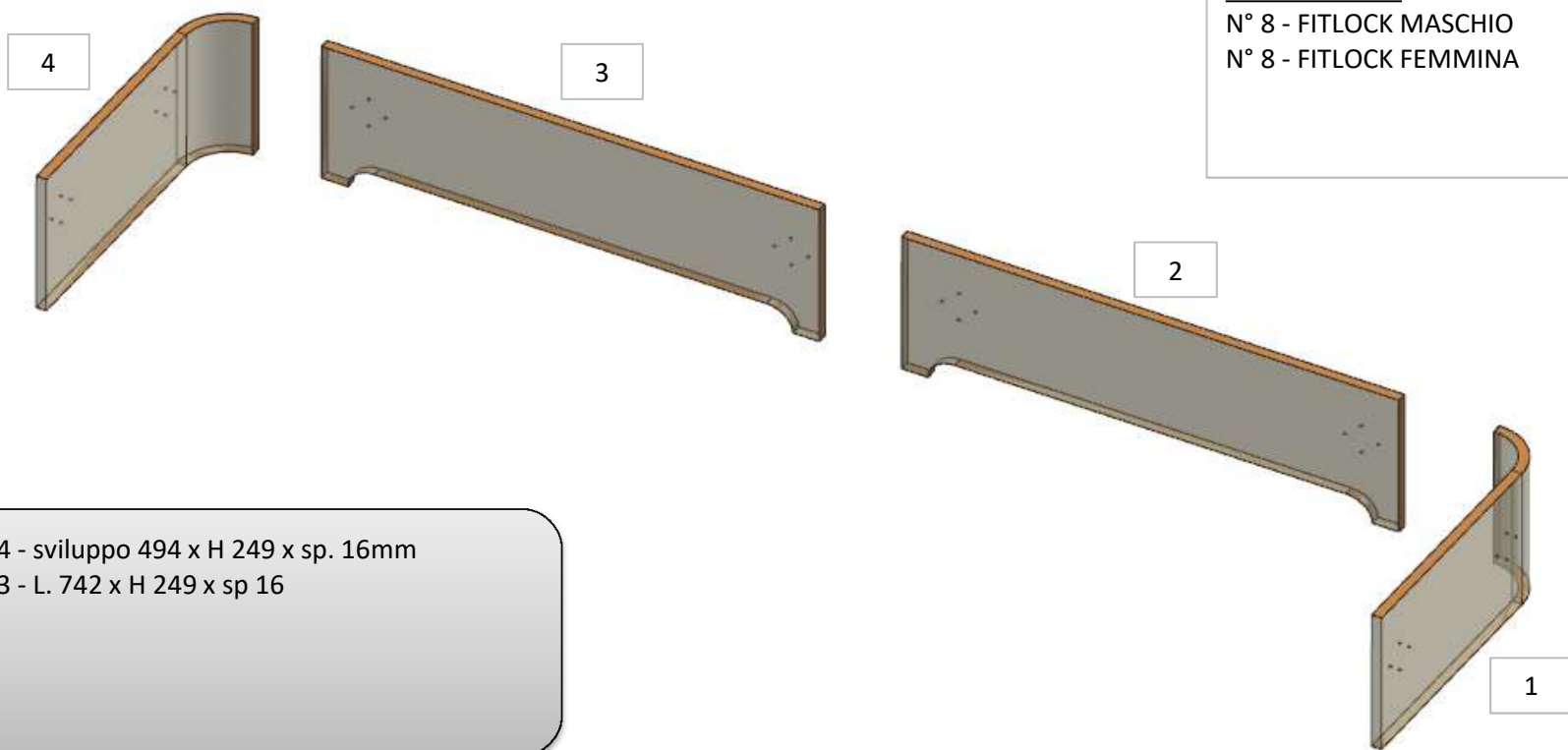

**FERRAMENTA:**  
N° 8 - FITLOCK MASCHIO  
N° 8 - FITLOCK FEMMINA

1/4 - sviluppo 494 x H 249 x sp. 16mm  
2/3 - L. 742 x H 249 x sp 16

# AZ68F

DA MAT. 203 REV. 29-04-2024

LOCALE	CODICE	DESCRIZIONE COMPONENTE	FINITURA	Q.TA	OPERATORE
SALONE A POPPA	AZ66F-R01_SSR01	DIVANO POPPA	LASTRA CHIARA	5	Damiano

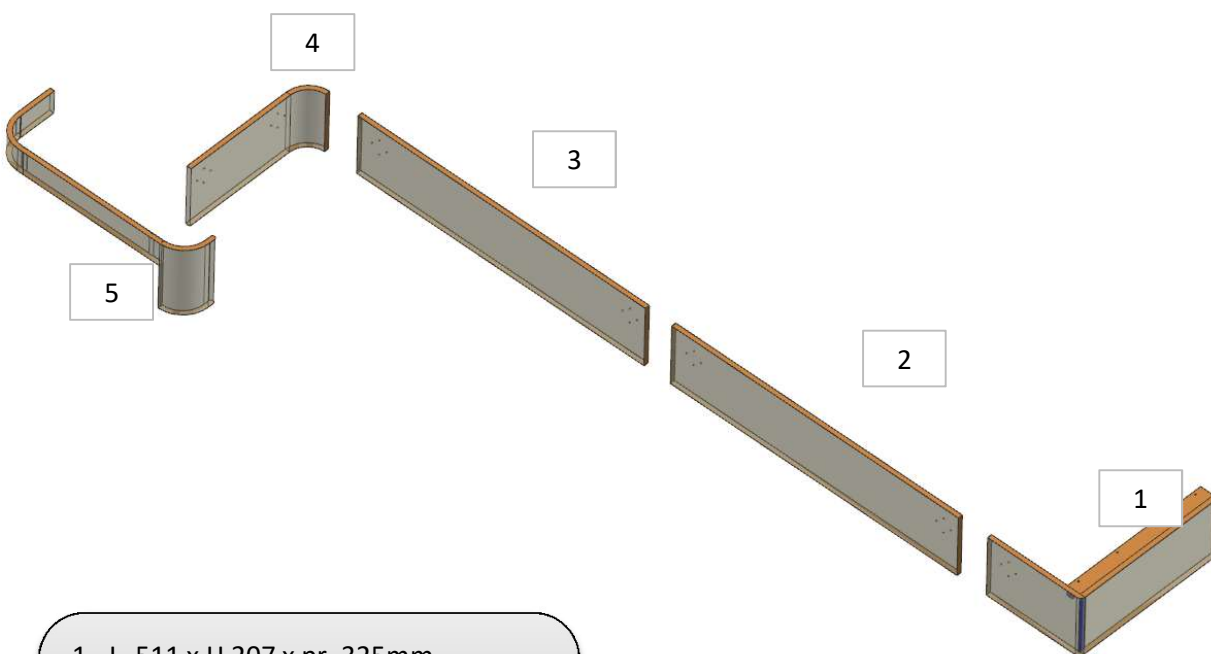

- 1 - L. 511 x H 207 x pr. 325mm
- 2 - L. 998 x H 207 x sp 16
- 3 - L. 1000 x H 207 x sp 16
- 4 - sviluppo 493 x H 207 x sp 16mm
- 5 - L. 674 x H 232 x pr. 217mm

**FERRAMENTA:**

- N° 7 - FITLOCK MASCHIO
- N° 7 - FITLOCK FEMMINA

**ELEMENTO DA MONTARE con:**  
**R01\_SSR01**  
e spedire con un unico imballo

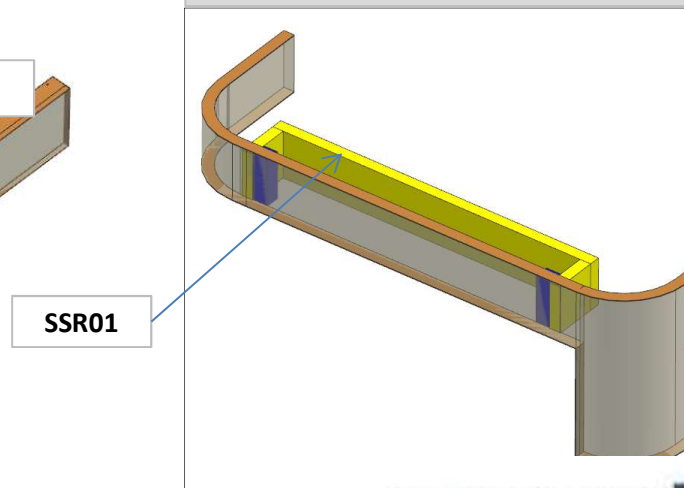

**consonni&c**