

AZ68F

DA MAT. 203 REV. 13-09-2021

LOCALE	CODICE	DESCRIZIONE COMPONENTE	FINITURA	Q.TA	OPERATORE
SALONE A POPPA	AZ68F-I01_SSC01	MURATA BASSA DX PRUA	OKOUME' GREZZO	1	Dante

1 - L 313 x H.416 x sp 30

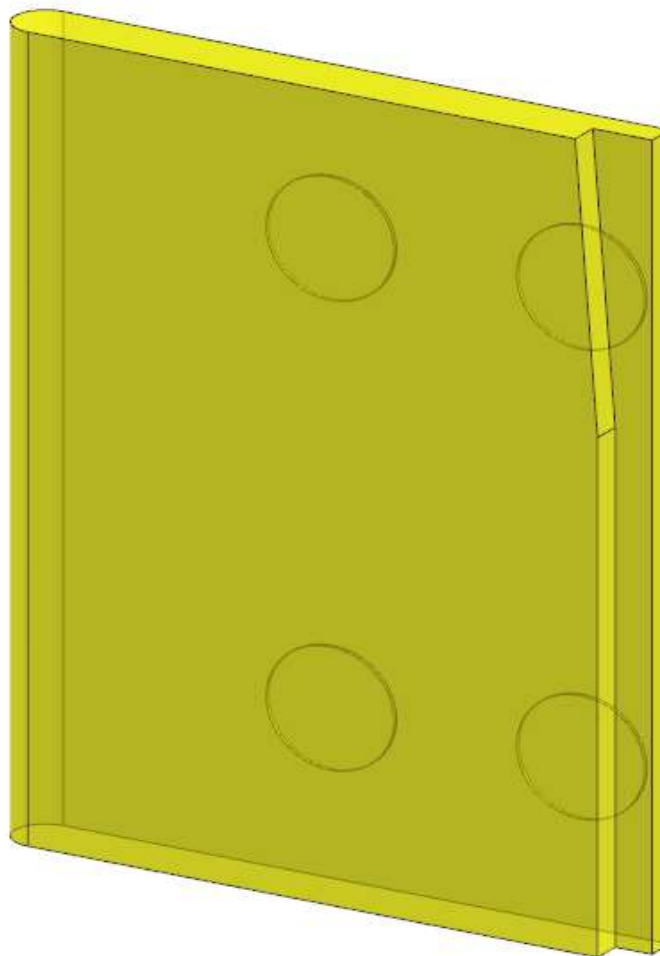

AZ68F

DA MAT. 203 REV. 13-09-2021

LOCALE	CODICE	DESCRIZIONE COMPONENTE	FINITURA	Q.TA	OPERATORE
SALONE A POPPA	AZ68F-I01_SSE01	CASSAPANCA DX	OKOUME' GREZZO	2	Dante

- 1 - L.387 x H.250 x sp 6
- 2 - L.505 x H.387 x sp 6

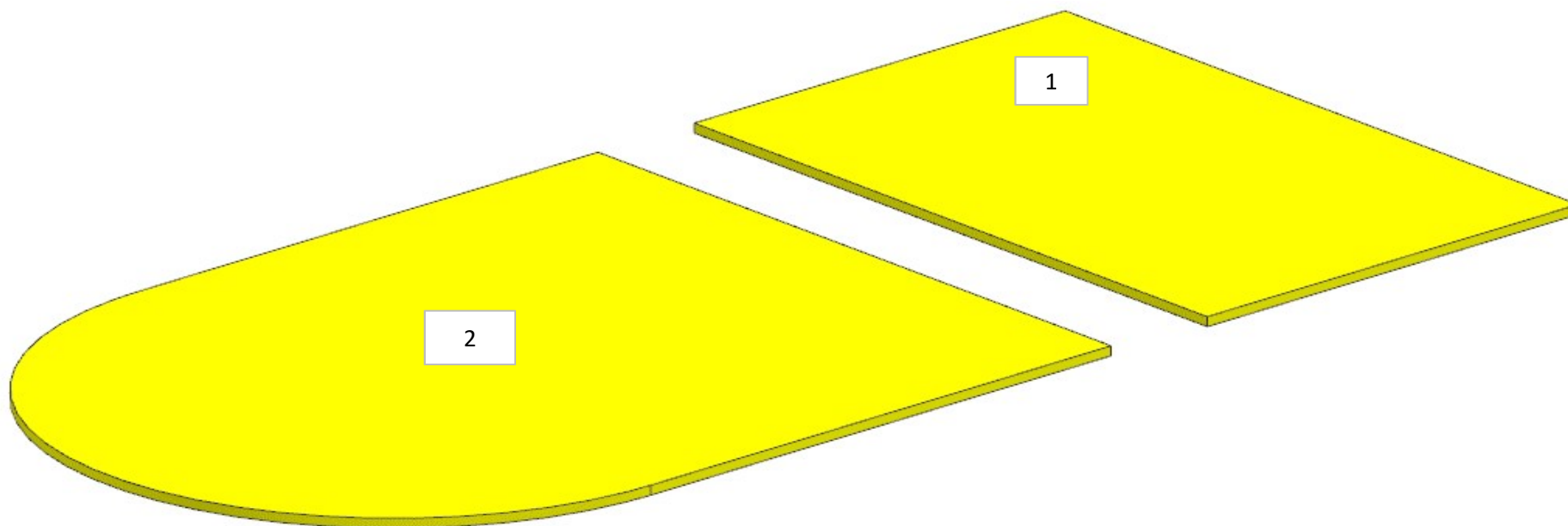

AZ68F

DA MAT.212 REV. 13-09-2021

LOCALE	CODICE	DESCRIZIONE COMPONENTE	FINITURA	Q.TA	OPERATORE
SALONE A POPPA	AZ68F-I01_SSG01	STRUTTURA MURATA BASSA DX	OKOUME' GREZZO	2	Dante

1 - L 3005 x H 152 x sp 15 mm
2 - L 2696 x H 297 x sp 15 mm

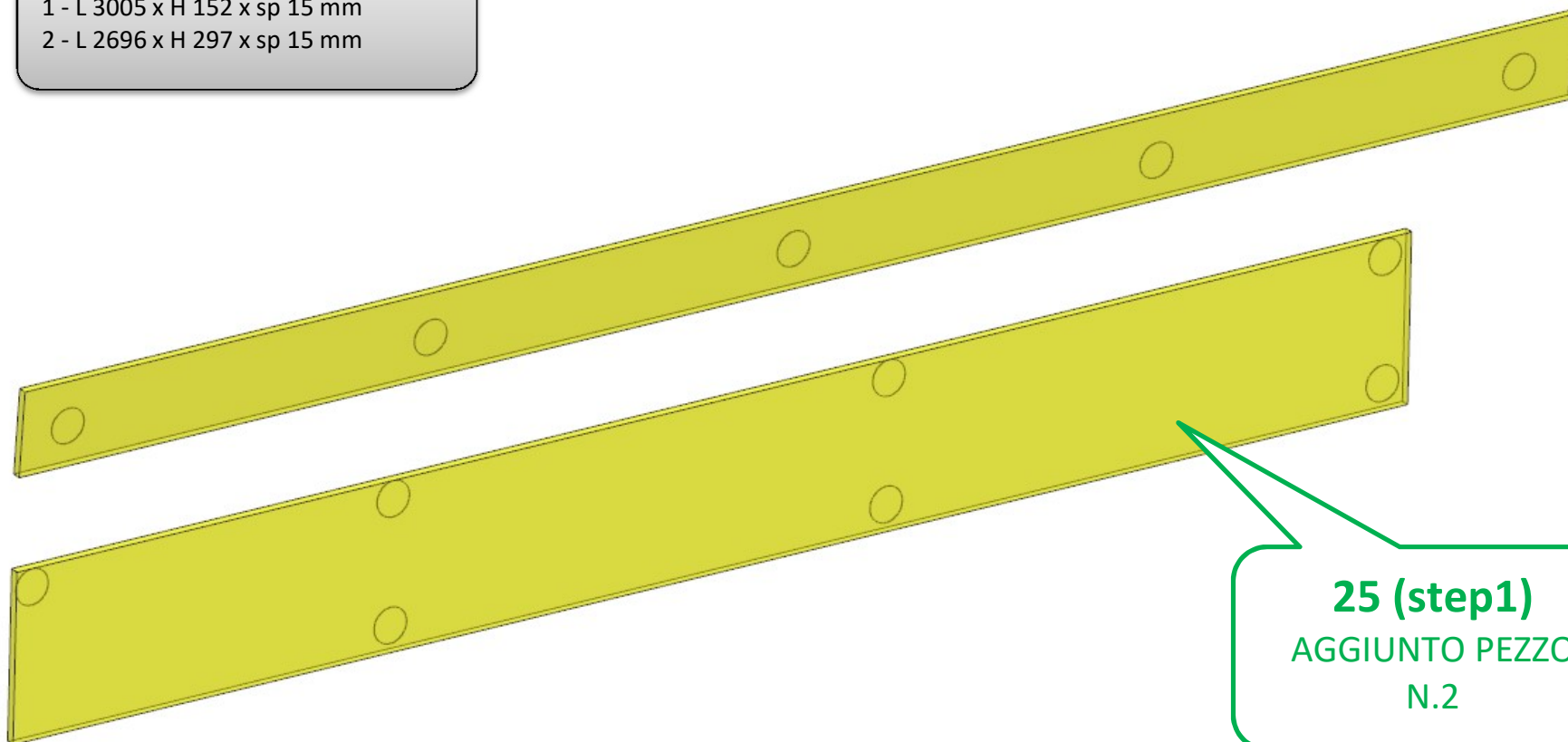

AZ68F

DA MAT. 203 REV. 13-09-2021

LOCALE	CODICE	DESCRIZIONE COMPONENTE	FINITURA	Q.TA	OPERATORE
SALONE A POPPA	AZ66F-I01_SSH01	COLONNA POPPA MURATA DX	OKOUME' GREZZO	1	Dante

1 - L.305 x H 398 x sp 15

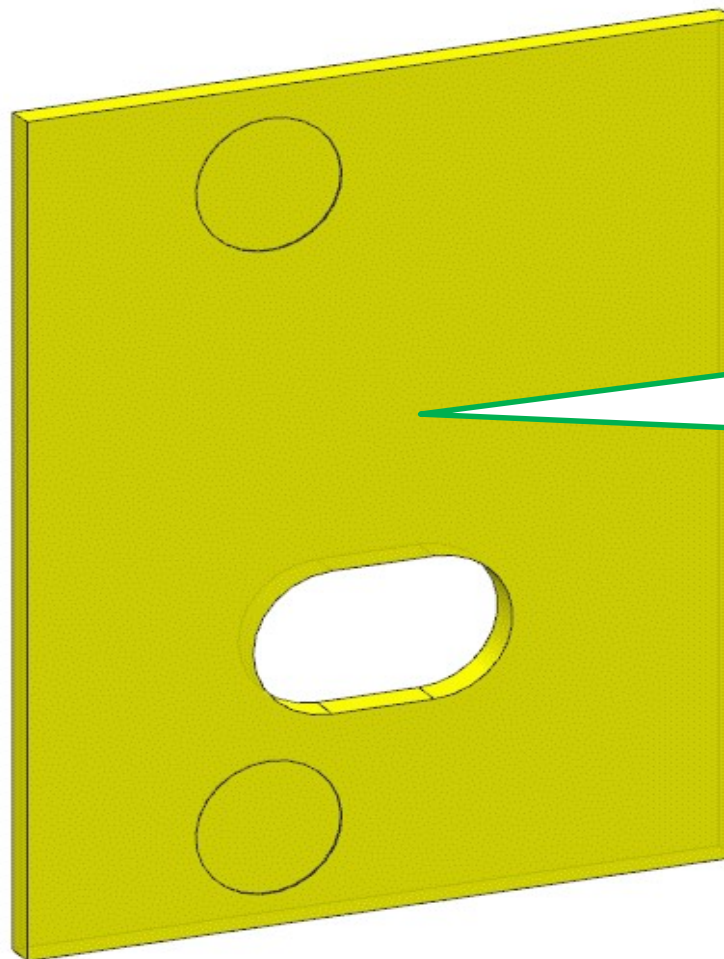

1-2
AGGIUNTO
IMBOTTITO E FORO
PER PRESA

AZ68F

DA MAT. 212 REV. 13-09-2021

LOCALE	CODICE	DESCRIZIONE COMPONENTE	FINITURA	Q.TA	OPERATORE
SALONE A POPPA	AZ68F-I01_SSM01	MURATA BASSA SX PRUA	OKOUME' GREZZO	4	Dante

- 1 - L.1727 x H 460 x sp 10mm
- 2 - L.1727 x H 40 x sp 6mm
- 3 - L.1723 x H 670 x sp 10mm
- 4 - L.824 x H.193 x sp 6

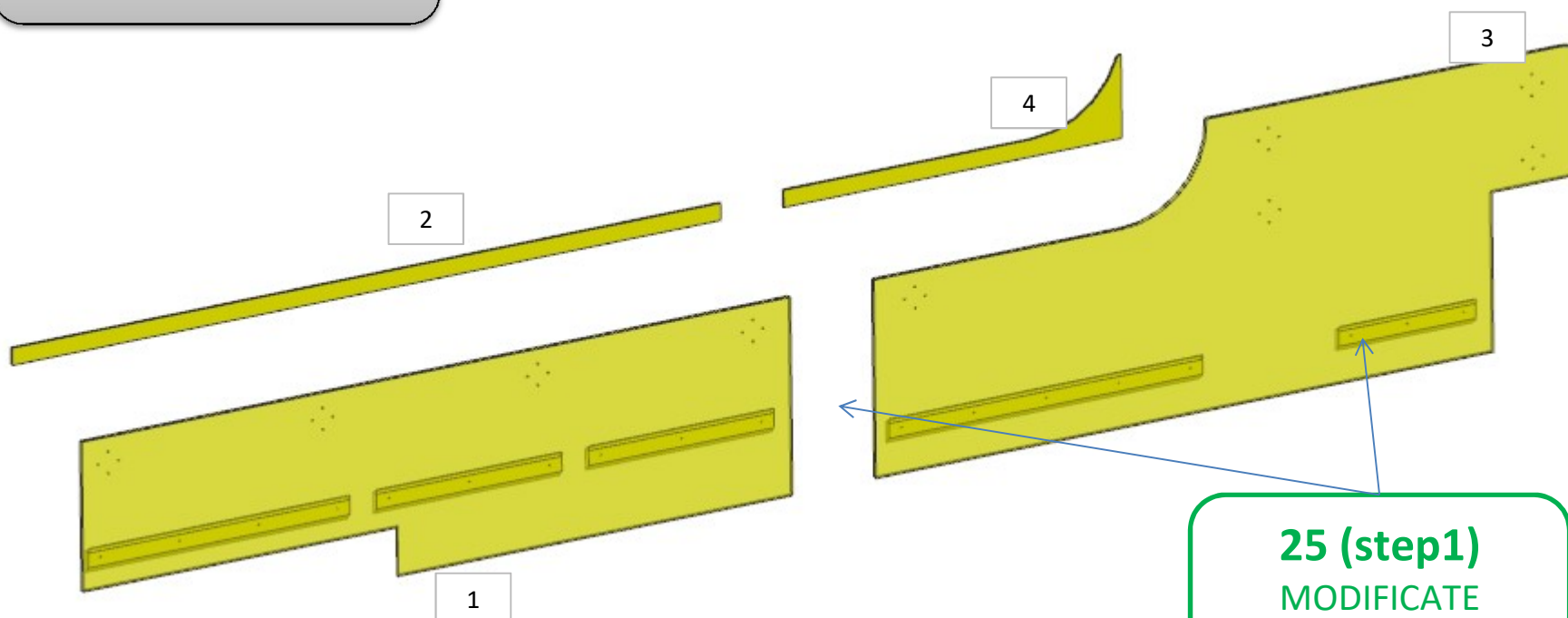

25 (step1)
MODIFICATE
DIMENSIONI

AZ68F

DA MAT. 203 REV. 13-09-2021

LOCALE	CODICE	DESCRIZIONE COMPONENTE	FINITURA	Q.TA	OPERATORE
SALONE A POPPA	AZ66F-I01_SSO01	TAVOLO	OKOUME' GREZZO	2	Damiano

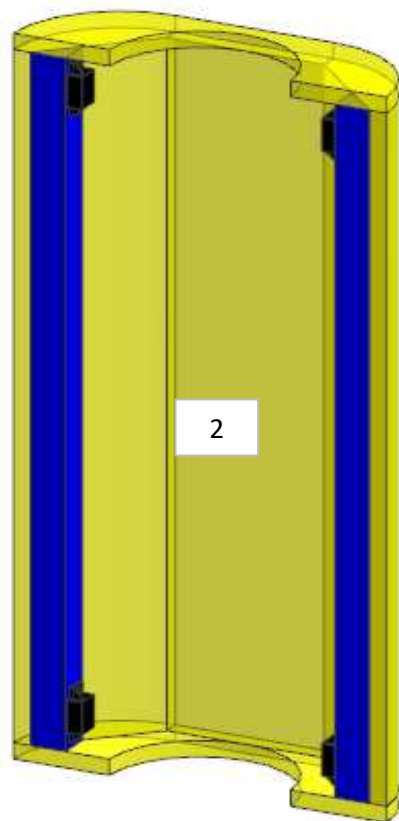
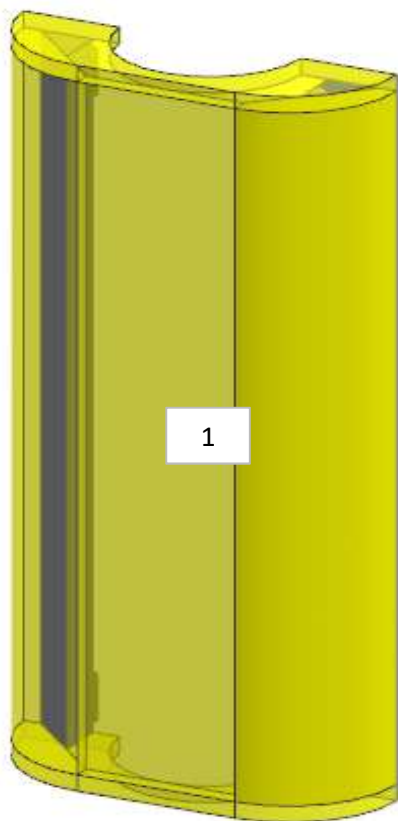

**ELEMENTO DA MONTARE:
R01-SSO01
I01-SSO01
e spedire con un unico imballo**

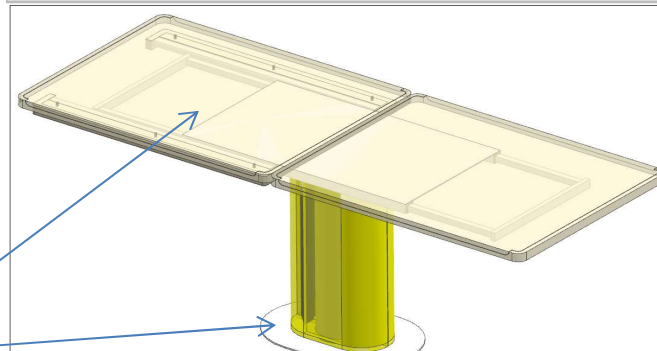

R01_SSO01

A01_SSO01

consonni&c