

AZ68F

DA MAT.203

REV. 18-10-2022

LOCALE	CODICE	DESCRIZIONE COMPONENTE	FINITURA	Q.TA	OPERATORE
SALONE A POPPA	AZ68F-A01_SSA01	PARETE DIVISORIA LATO POPPA	ACCIAIO LACCATO BRONZO	1	Damiano

1 - L 1514 x H 40 x sp 17mm



DETTAGLIO

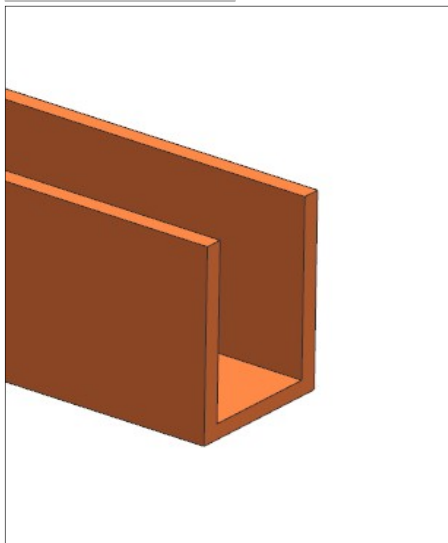

consonni&c

AZ68F

DA MAT. 233 REV. 18-10-2022

LOCALE	CODICE	DESCRIZIONE COMPONENTE	FINITURA	Q.TA	OPERATORE
SALONE A POPPA	AZ68F-A01_SSB01	LANTERNA DIVISORIA PRUA	ACCIAIO LACCATO BRONZO	6	Damiano

DETTAGLIO

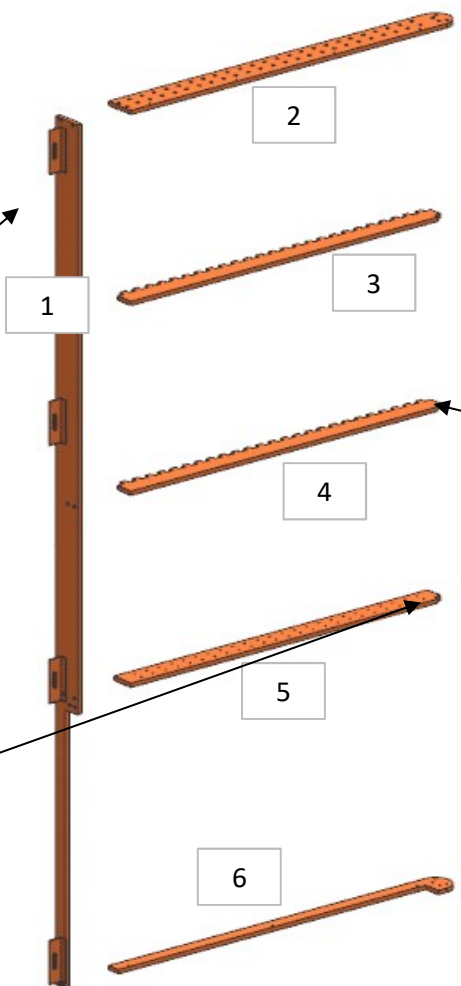
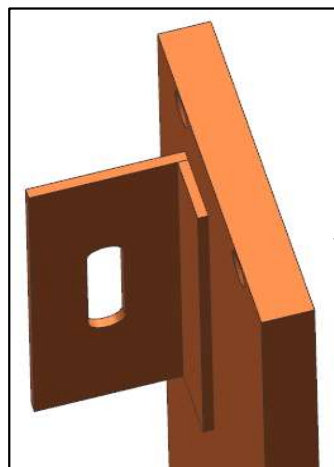

- 1 - L 67 x H 1973 x sp 10
- 2 - L 804 x H 67 x sp 10
- 3 - 4 - L765 x H 51 x sp 10
- 5 - L 51 x H 765 x sp 10
- 6 - L 67 x H 804 x sp 10

DETTAGLIO

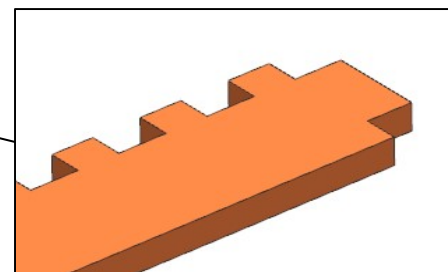

ELEMENTO DA MONTARE con:
L01_SSB01
R01_SSB01
 e spedire con un unico imballo

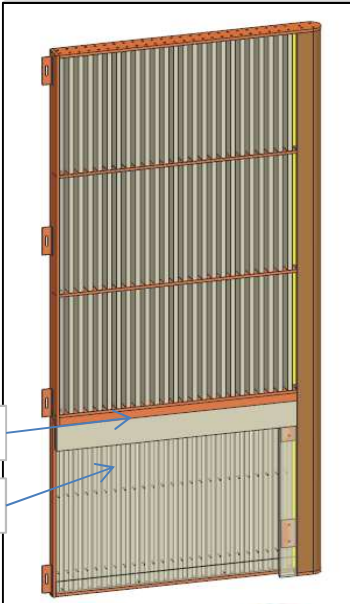
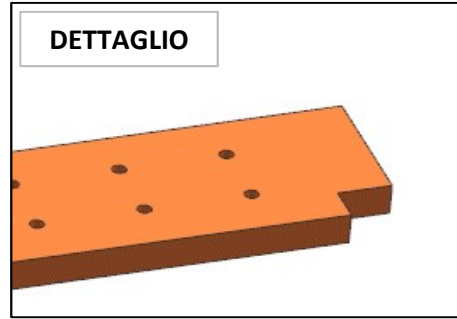

AZ68F

DA MAT. 203 REV. 18-10-2022

LOCALE	CODICE	DESCRIZIONE COMPONENTE	FINITURA	Q.TA	OPERATORE
SALONE A POPPA	AZ68F-A01_SSC01	MURATA BASSA DX PRUA	ACCIAIO	2	Damiano

1 - L 271,5 x H 945 x sp 1.5 mm
2 - L 271,5 x H 945 x sp 1.5 mm

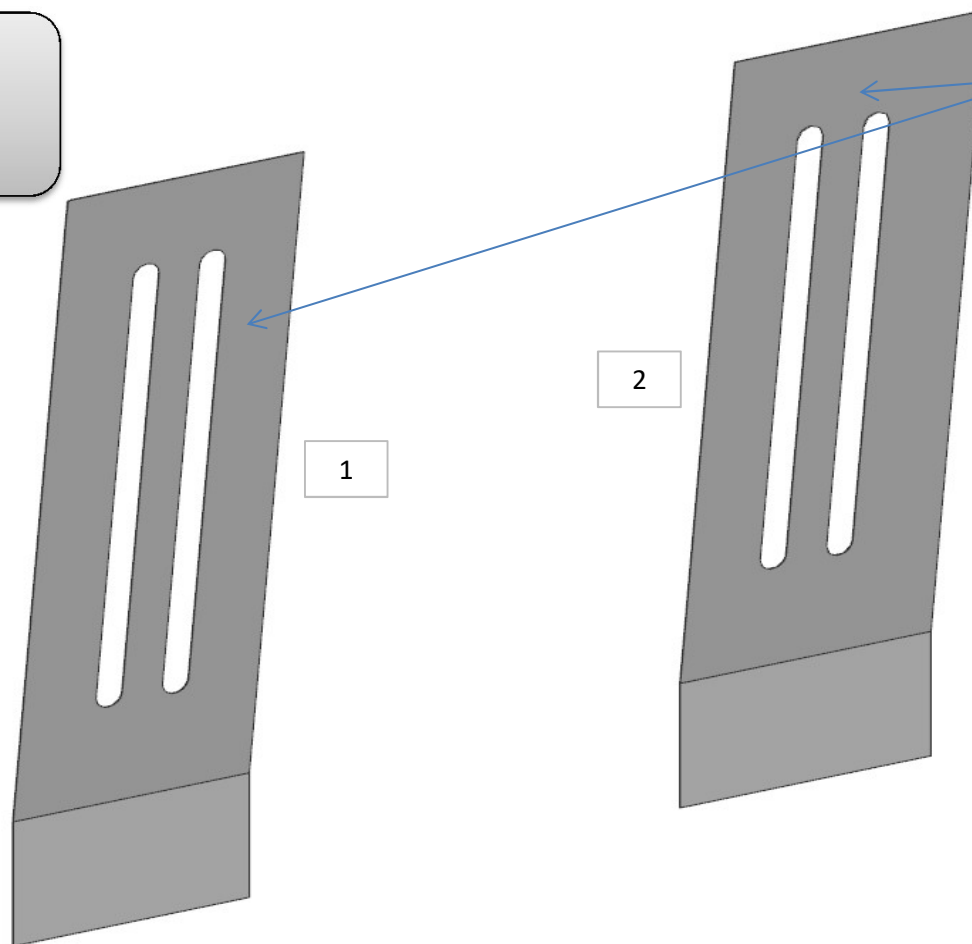

LATO BELLO

AZ68F

DA MAT. 203 REV. 18-10-2022

LOCALE	CODICE	DESCRIZIONE COMPONENTE	FINITURA	Q.TA	OPERATORE
SALONE A POPPA	AZ68F-A01_SSM01	MURATA BASSA SX PRUA	ACCIAIO	1	Damiano

1 - L 1012 x H.320 x sp 1,5

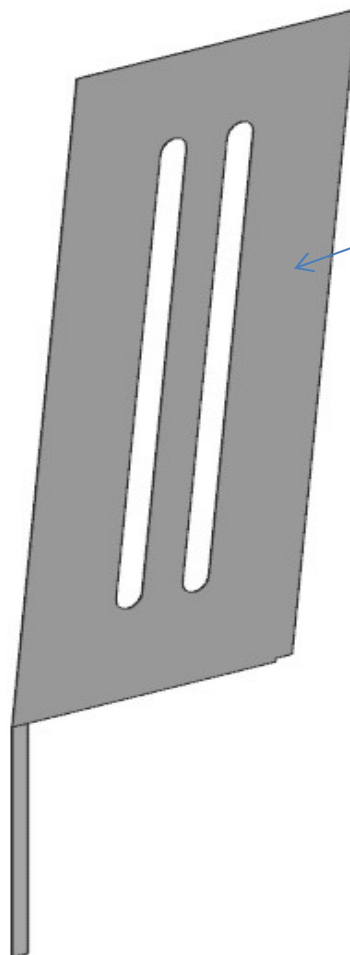

LATO BELLO

AZ68F

DA MAT. 203 REV. 18-10-2022

LOCALE	CODICE	DESCRIZIONE COMPONENTE	FINITURA	Q.TA	OPERATORE
SALONE A POPPA	AZ66F-A01_SSO01	TAVOLO	ACCIAIO	1	Damiano



ELEMENTO DA MONTARE:
R01-SSO01
I01-SSO01
e spedire con un unico imballo

R01_SSO01

I01_SSO01

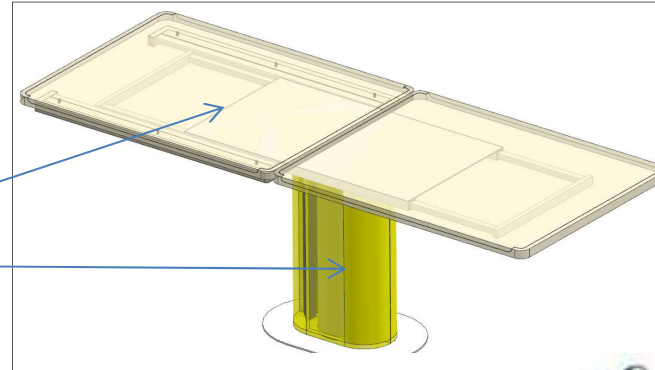

consonni&c