

AZ68F

DA MAT. 265 REV. 29-04-2024

| LOCALE | CODICE | DESCRIZIONE COMPONENTE | FINITURA | Q.TA | OPERATORE |
|--------|------------|------------------------|---------------------------|------|-----------|
| LOBBY | AZ68F-CA01 | MOBILE LAVATRICE | LAMINATO NADIR\ GREZZO | 4 | Damiano |

2/3 - L 650 x H 637 x 46mm
4 - L 652 x H 66 x sp 16mm

186
CASSA DIVISA IN

SPRUZZARE DI NERO
TUTTE LE FRESATE

FERRAMENTA:

- N° 3 - CERNIERA PIANA
- N° 3 - BASETTA H 6
- N° 12 - ANKOR BORGHI
- N° 2 - GOMMINO PARACOLPO
- N° 2 - CALAMITA NERA
- N° 2 - RISCONTRO CALAMITA NERA
- N° 1 - KIT MANIGLIA FORESTI E SUARDI BAGNI
- N° 2 - SOUTHCO
- N° 2 - RISCONTRO SOUTHCO
- N° 8 - REGGIRIPIANO 1 PERNO 1 N° 14 - FORO VITI 6MA X 25 TB

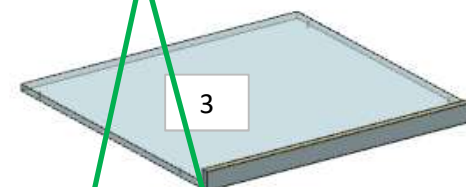
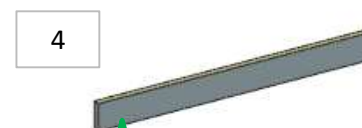
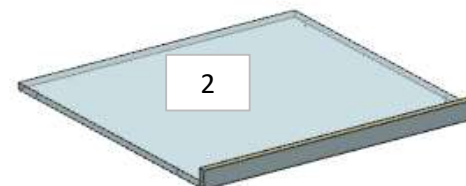
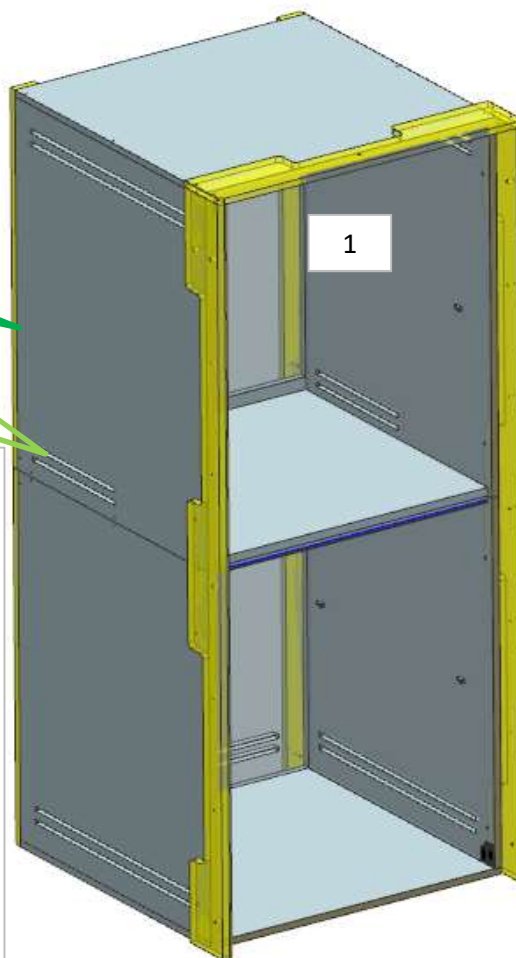

186
NON INCOLLARE
ANTIROLLIO N.4 -
COSEGNARE SFUSO

ELEMENTO MONTATO
come:
MG_CA01
e spedire con un unico

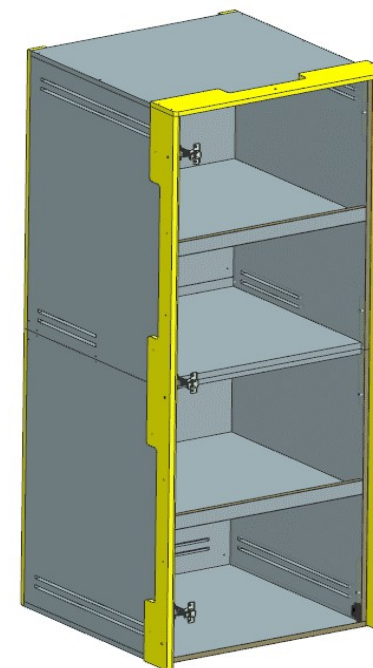

AZ68F

DA MAT. 203 REV. 29-04-2024

| LOCALE | CODICE | DESCRIZIONE COMPONENTE | FINITURA | Q.TA | OPERATORE |
|--------|------------|------------------------|----------------|------|-----------|
| LOBBY | AZ68F-CB01 | GRADINI SCALA | OKOUME' GREZZO | 22 | Damiano |

- 1 -sviluppo 756 x H.60 x sp 19
- 2 - L.650 x H 113 x sp 30
- 3 - 7 - L.610 x H 221 x sp 19
- 4 - 6 - 8 - L.610 x H 106 x sp 30
- 5 - L.610 x H 220 x sp 19
- 9 - L.610 x H 457 x sp 19
- 10 - L.751 x H 106 x sp 30
- 11 - L.573 x H 203 x 478
- 12 - L.768 x H 106 x 587
- 13 - L.431 x H 308 x sp 19
- 14 - L.460 x H 483 x sp 19
- 15 - L.609 x H 106 x sp 51
- 16 - L.598 x H 106 x sp 51
- 17 -L.672 x H.101 x sp 19
- 18 - L.635 x H 106 x sp 51
- 19 -L.719 x H.103 x sp 19
- 20 - L.725 x H 106 x sp 51
- 21 -L.760 x H.101 x sp 19
- 22 - L.760 x H 106 x sp 51

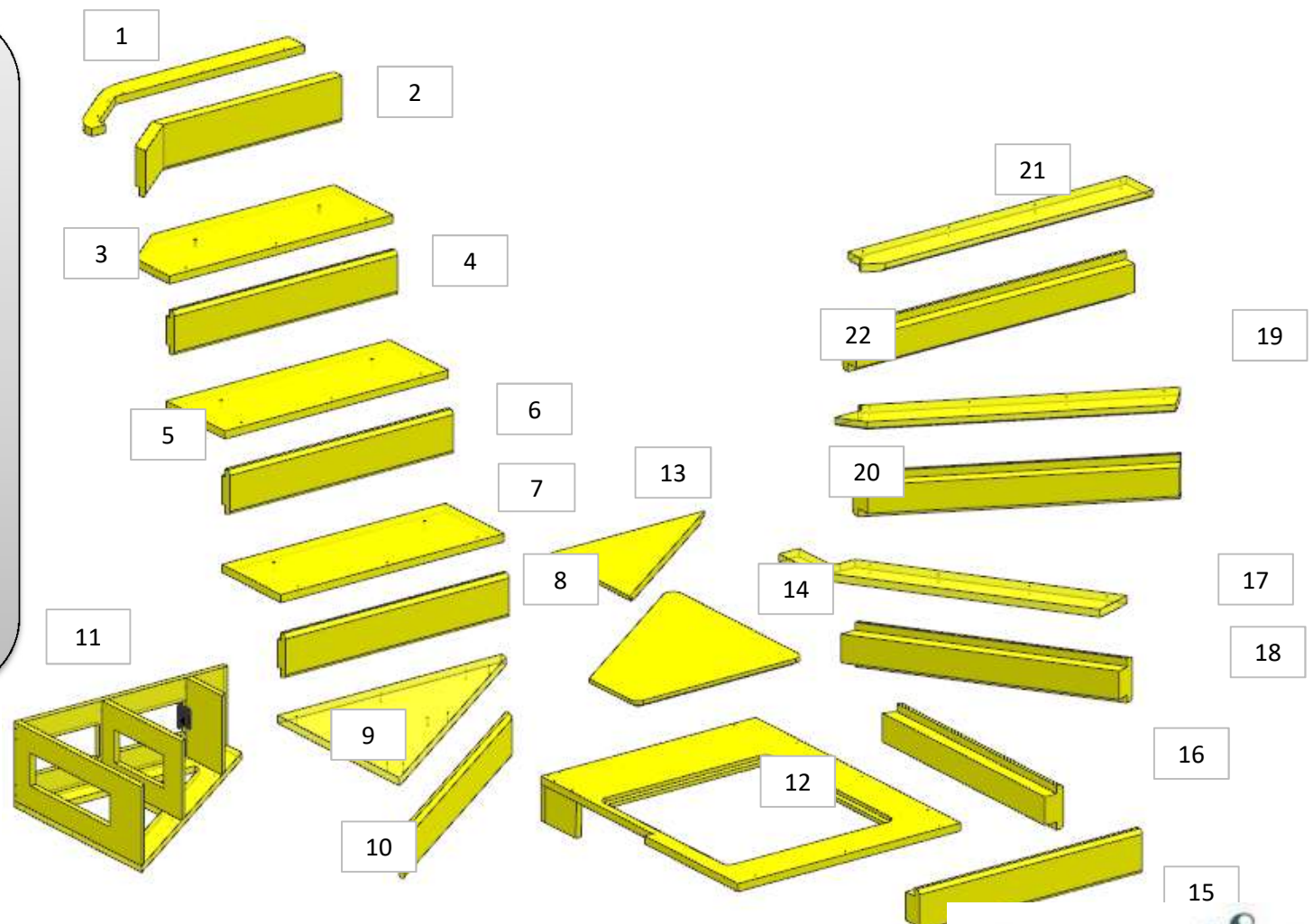

FERRAMENTA:

N° 6 - VITI 6MA

AZ68F

DA MAT. 211 REV. 29-04-2024

| LOCALE | CODICE | DESCRIZIONE COMPONENTE | FINITURA | Q.TA | OPERATORE |
|--------|------------|-----------------------------|-------------------------|------|-----------|
| LOBBY | AZ68F-CE01 | UNITA' TRATTAMENTO ARIA OPT | OKOUME' VERNICIATO NERO | 1 | Dante |

1 - L.931 x H.140 x pr.287mm

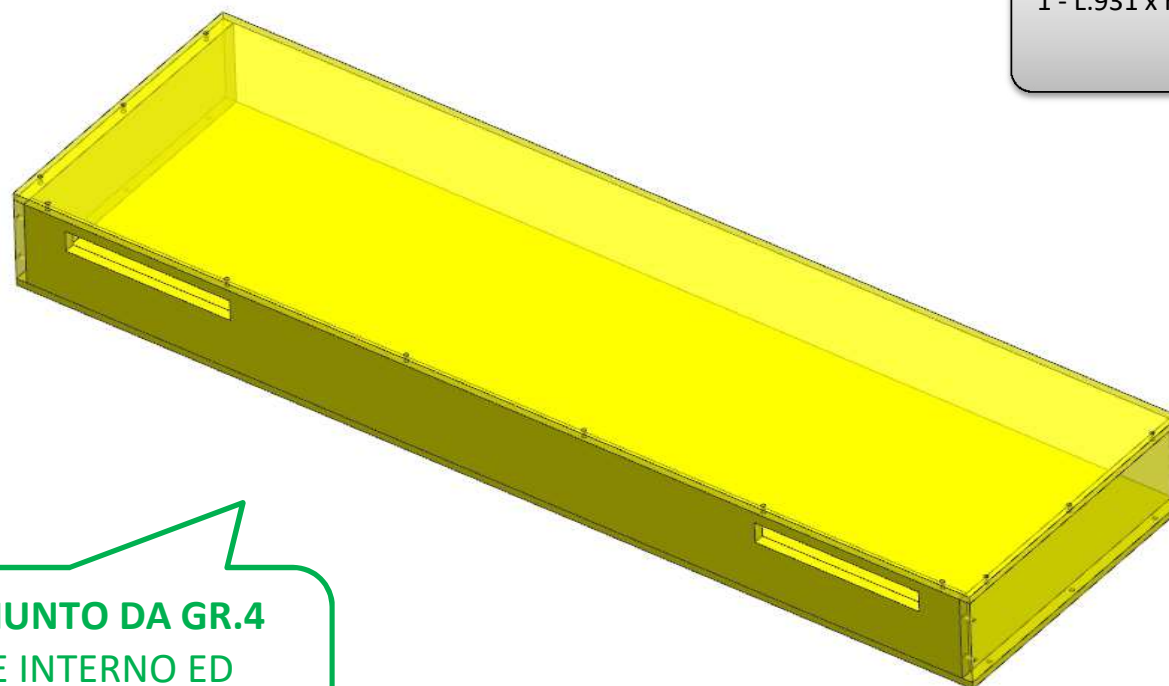

CODICE AGGIUNTO DA GR.4
VERNICIARE INTERNO ED
ESTERNO NERO OPACO

AZ68F

DA MAT. 265 REV. 29-04-2024

| LOCALE | CODICE | DESCRIZIONE COMPONENTE | FINITURA | Q.TA | OPERATORE |
|--------|------------|------------------------|----------------|------|-----------|
| LOBBY | AZ68F-CF01 | PARETE LAVATRICE | OKOUME' GREZZO | 1 | Damiano |

da mat.203
AUMENTATA
DIMENSIONE
FINESTRA

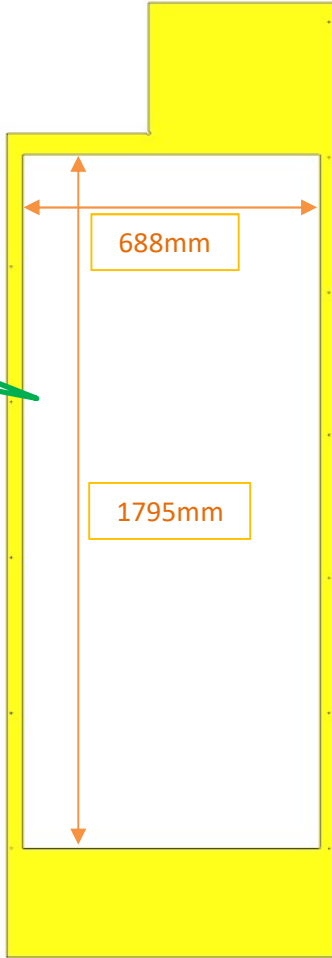

1 - L 755 x H 2470 x sp 15